



SGI InfiniteStorage 4000 Series and 5000 Series Storage Systems Guide

(ISSM 10.80)

The information in this document supports the SGI InfiniteStorage 4000 series and 5000 series storage systems (ISSM 10.80). Refer to the table below to match your specific SGI InfiniteStorage product with the model numbers used in this document.

| SGI Model # | Netapp Model | Netapp Compliance Model | Notes |
|------------------------------|---|--------------------------------|---------------------------|
| TP9600H | 6091 (XBB1) | 1500 | |
| TP9700F | 6091 (XBB1) | 1500 | |
| IS4500F | 6091 (XBB1) | 1500 | |
| TP9600F | 3994 and 3992 | 4600 | |
| IS4000H | 3994 | 4600 | |
| IS350 | 3992 | 4600 | |
| IS220 | 1932 (MaryJane) 1333 (Keystone) DE1300 (Shea) | 3600 | |
| IS4100 | 4900 (Matterhorn) | 4600 | FC HICs only |
| IS-DMODULE16-Z | FC4600 (Wrigley) | 4600 | |
| IS-DMODULE60 | DE6900 (Wembley-FC) | 6900 | |
| IS4600 | 7091 (XBB2) | 1550 | 4Gb FC, 8Gb FC, HICs only |
| IS5012 | 2600 (Snowmass) | 3650 | FC and SAS HICs only |
| IS5024 | 2600 (Snowmass) | 5350 | |
| IS5060 | 2600 (Snowmass) | 6600 | |
| IS-DMODULE12 & IS2224 (JBOD) | DE1600 (Ebbets) | 3650 | |
| IS-DMODULE24 | DE5600 (Camden) | 5350 | |
| IS-DMODULE60-SAS | DE6600 (W-SAS) | 6600 | |
| IS5512 | 5400 (Pike Peak) | 3650 | |
| IS5524 | 5400 (Pike Peak) | 5350 | |
| IS5560 | 5400 (Pike Peak) | 6600 | |

Table of Contents

| | |
|--|-----------|
| Electronic Document for SANtricity 10.80..... | 34 |
| SANtricity ES Concepts for Version 10.80..... | 35 |
| Storing Your Data..... | 36 |
| Storage Arrays..... | 36 |
| Storage Area Networks..... | 36 |
| Management Methods..... | 36 |
| Out-of-Band Management..... | 37 |
| In-Band Management..... | 37 |
| RAID Levels and Data Redundancy..... | 37 |
| Dynamic RAID-Level Migration..... | 38 |
| RAID Level Configuration Table..... | 38 |
| Hardware Redundancy..... | 39 |
| Controller Cache Memory..... | 40 |
| Tray Loss Protection..... | 40 |
| Drawer Loss Protection..... | 41 |
| Hot Spare Drives..... | 42 |
| Channel Protection..... | 43 |
| I/O Data Path Protection..... | 43 |
| Multi-Path Driver with AVT Enabled..... | 43 |
| Multi-Path Driver with AVT Disabled..... | 44 |
| Target Port Group Support..... | 44 |
| Load Balancing..... | 44 |
| Round Robin with Subset..... | 45 |
| Least Queue Depth with Subset..... | 45 |
| Least Path Weight with Subset..... | 45 |
| Introducing the Storage Management Software..... | 46 |
| Enterprise Management Window..... | 46 |
| Parts of the Enterprise Management Window..... | 46 |
| EMW Devices Tab..... | 47 |
| EMW Setup Tab..... | 49 |
| Adding and Removing a Storage Array..... | 49 |
| Array Management Window..... | 50 |
| Starting the Array Management Window..... | 50 |
| Summary Tab..... | 50 |
| Logical Tab..... | 51 |
| Physical Tab..... | 52 |
| Mappings Tab..... | 54 |
| AMW Setup Tab..... | 56 |
| Support Tab..... | 57 |
| Managing Multiple Software Versions..... | 57 |
| Configuring the Storage Arrays..... | 58 |
| Volumes and Volume Groups..... | 58 |
| Standard Volumes..... | 58 |
| Volume Groups..... | 59 |
| Volume Group Creation..... | 59 |
| Dynamic Capacity Expansion..... | 61 |
| Register the Volume with the Operating System..... | 62 |
| Premium Features..... | 62 |
| SANshare Storage Partitioning..... | 62 |
| Snapshot Volume Premium Feature..... | 63 |
| Remote Volume Mirroring Premium Feature..... | 67 |

| | |
|---|------------|
| Volume Copy Premium Feature..... | 70 |
| SafeStore Drive Security and SafeStore Enterprise Key Manager..... | 76 |
| SafeStore Data Assurance Premium Feature..... | 80 |
| Solid State Disks..... | 80 |
| Heterogeneous Hosts..... | 81 |
| Password Protection..... | 82 |
| Persistent Reservations Management..... | 82 |
| HotScale Technology..... | 83 |
| Maintaining and Monitoring Storage Arrays..... | 84 |
| Storage Array Health..... | 84 |
| Background Media Scan..... | 84 |
| Event Monitor..... | 84 |
| Alert Notifications..... | 85 |
| Performance Monitor..... | 86 |
| Viewing Operations in Progress..... | 89 |
| Retrieving Trace Buffers..... | 89 |
| Upgrading the Controller Firmware..... | 90 |
| Monitoring the Status of the Download..... | 91 |
| Problem Notification..... | 93 |
| Event Log Viewer..... | 93 |
| Storage Array Problem Recovery..... | 94 |
| Recovery Guru..... | 94 |
| Glossary..... | 95 |
| A..... | 95 |
| C..... | 95 |
| D..... | 95 |
| F..... | 96 |
| H..... | 96 |
| I..... | 97 |
| L..... | 97 |
| M..... | 97 |
| N..... | 97 |
| O..... | 97 |
| P..... | 98 |
| R..... | 98 |
| S..... | 100 |
| T..... | 102 |
| U..... | 102 |
| V..... | 102 |
| W..... | 102 |
| Storage System Site Preparation Guide..... | 103 |
| Specifications of the Model 3040 40U Cabinet..... | 106 |
| Model 3040 40U Cabinet Configurations..... | 108 |
| Model 3040 40U Cabinet Dimensions..... | 110 |
| Model 3040 40U Cabinet Weights..... | 110 |
| Model 3040 40U Cabinet Temperature and Humidity..... | 112 |
| Model 3040 40U Cabinet Altitude Ranges..... | 112 |
| Model 3040 40U Cabinet Airflow, Heat Dissipation, and Service Clearances..... | 112 |
| Model 3040 40U Cabinet Site Wiring and Power..... | 113 |
| Model 3040 40U Cabinet Power Requirements..... | 114 |
| Model 3040 40U Cabinet Grounding..... | 116 |
| Model 3040 40U Cabinet Power Distribution..... | 116 |
| Model 3040 40U Cabinet Power Cords and Receptacles..... | 118 |
| Specifications of the CE7900 Controller Tray..... | 120 |

| | |
|---|-----|
| CE7900 Controller Tray Dimensions..... | 121 |
| CE7900 Controller Tray Weight..... | 121 |
| CE7900 Controller Tray Shipping Dimensions..... | 122 |
| CE7900 Controller Tray Temperature and Humidity..... | 122 |
| CE7900 Controller Tray Altitude Ranges..... | 123 |
| CE7900 Controller Tray Airflow and Heat Dissipation..... | 123 |
| CE7900 Controller Tray Acoustic Noise..... | 124 |
| CE7900 Controller Tray Site Wiring and Power..... | 124 |
| CE7900 Controller Tray Power Cords and Receptacles..... | 125 |
| Preparing the Network for the Controllers..... | 125 |
| Specifications of the CE7922 Controller Tray..... | 127 |
| CE7922 Controller Tray Dimensions..... | 128 |
| CE7922 Controller Tray Weight..... | 128 |
| CE7922 Controller Tray Shipping Dimensions..... | 129 |
| CE7922 Controller Tray Temperature and Humidity..... | 129 |
| CE7922 Controller Tray Altitude Ranges..... | 130 |
| CE7922 Controller Tray Airflow and Heat Dissipation..... | 130 |
| CE7922 Controller Tray Acoustic Noise..... | 131 |
| CE7922 Controller Tray Site Wiring and Power..... | 131 |
| CE7922 Controller Tray Power Cords and Receptacles..... | 132 |
| Preparing the Network for the Controllers..... | 132 |
| Specifications of the CE6998 Controller Tray..... | 134 |
| CE6998 Controller Tray Dimensions..... | 134 |
| CE6998 Controller Tray Weight..... | 135 |
| CE6998 Controller Tray Shipping Dimensions..... | 136 |
| CE6998 Controller Tray Temperature and Humidity..... | 136 |
| CE6998 Controller Tray Altitude Ranges..... | 136 |
| CE6998 Controller Tray Airflow and Heat Dissipation..... | 137 |
| CE6998 Controller Tray Acoustic Noise..... | 137 |
| CE6998 Controller Tray Site Wiring and Power..... | 138 |
| CE6998 Controller Tray Power Cords and Receptacles..... | 138 |
| Preparing the Network for the Controllers..... | 139 |
| Specifications of the CE2600 Controller-Drive Tray..... | 140 |
| CE2600 Controller-Drive Tray Dimensions..... | 141 |
| CE2600 Controller-Drive Tray Weight..... | 142 |
| CE2600 Controller-Drive Tray Shipping Dimensions..... | 143 |
| CE2600 Controller-Drive Tray Temperature and Humidity..... | 143 |
| CE2600 Controller-Drive Tray Altitude Ranges..... | 144 |
| CE2600 Controller-Drive Tray Airflow and Heat Dissipation..... | 144 |
| CE2600 Controller-Drive Tray Acoustic Noise..... | 145 |
| CE2600 Controller-Drive Tray Site Wiring and Power..... | 146 |
| CE2600 Controller-Drive Tray Power Input..... | 146 |
| CE2600 Controller-Drive Tray Power Factor Correction..... | 147 |
| CE2600 Controller-Drive Tray AC Power Cords and Receptacles..... | 147 |
| CE2600 Controller-Drive Tray Optional DC Power Connector Cables and Source Wires..... | 147 |
| Preparing the Network for the Controllers..... | 148 |
| Specifications of the CE2600-60 Controller-Drive Tray..... | 149 |
| CE2600-60 Controller-Drive Tray Dimensions..... | 149 |
| CE2600-60 Controller-Drive Tray Weight..... | 150 |
| CE2600-60 Controller-Drive Tray Shipping Dimensions..... | 151 |
| CE2600-60 Controller-Drive Tray Temperature and Humidity..... | 151 |
| CE2600-60 Controller-Drive Tray Altitude Ranges..... | 152 |
| CE2600-60 Controller-Drive Tray Airflow and Heat Dissipation..... | 152 |
| CE2600-60 Controller-Drive Tray Acoustic Noise..... | 153 |

| | |
|---|-----|
| CE2600-60 Controller-Drive Tray Site Wiring and Power..... | 153 |
| CE2600-60 Controller-Drive Tray Power Input..... | 153 |
| CE2600-60 Controller-Drive Tray Power Factor Correction..... | 154 |
| CE2600-60 Controller-Drive Tray AC Power Cords and Receptacles..... | 154 |
| Preparing the Network for the Controllers..... | 154 |
| Specifications of the CE5400 Controller-Drive Tray..... | 155 |
| CE5400 Controller-Drive Tray Dimensions..... | 156 |
| CE5400 Controller-Drive Tray Weight..... | 157 |
| CE5400 Controller-Drive Tray Shipping Dimensions..... | 158 |
| CE5400 Controller-Drive Tray Temperature and Humidity..... | 158 |
| CE5400 Controller-Drive Tray Altitude Ranges..... | 159 |
| CE5400 Controller-Drive Tray Airflow and Heat Dissipation..... | 159 |
| CE5400 Controller-Drive Tray Acoustic Noise..... | 161 |
| CE5400 Controller-Drive Tray Site Wiring and Power..... | 161 |
| CE5400 Controller-Drive Tray Power Input..... | 162 |
| CE5400 Controller-Drive Tray Power Factor Correction..... | 162 |
| CE5400 Controller-Drive Tray AC Power Cords and Receptacles..... | 162 |
| CE5400 Controller-Drive Tray Optional DC Power Connector Cables and Source Wires..... | 163 |
| Preparing the Network for the Controllers..... | 163 |
| Specifications of the CE5400-60 Controller-Drive Tray..... | 165 |
| CE5400-60 Controller-Drive Tray Dimensions..... | 165 |
| CE5400-60 Controller-Drive Tray Weight..... | 166 |
| CE5400-60 Controller-Drive Tray Shipping Dimensions..... | 167 |
| CE5400-60 Controller-Drive Tray Temperature and Humidity..... | 167 |
| CE5400-60 Controller-Drive Tray Altitude Ranges..... | 168 |
| CE5400-60 Controller-Drive Tray Airflow and Heat Dissipation..... | 168 |
| CE5400-60 Controller-Drive Tray Acoustic Noise..... | 169 |
| CE5400-60 Controller-Drive Tray Site Wiring and Power..... | 169 |
| CE5400-60 Controller-Drive Tray Power Input..... | 169 |
| CE5400-60 Controller-Drive Tray Power Factor Correction..... | 170 |
| CE5400-60 Controller-Drive Tray AC Power Cords and Receptacles..... | 170 |
| Preparing the Network for the Controllers..... | 170 |
| Specifications of the CE4900 Controller-Drive Tray..... | 171 |
| CE4900 Controller-Drive Tray Dimensions..... | 171 |
| CE4900 Controller-Drive Tray Weight..... | 172 |
| CE4900 Controller-Drive Tray Shipping Dimensions..... | 173 |
| CE4900 Controller-Drive Tray Temperature and Humidity..... | 173 |
| CE4900 Controller-Drive Tray Altitude Ranges..... | 174 |
| CE4900 Controller-Drive Tray Airflow and Heat Dissipation..... | 174 |
| CE4900 Controller-Drive Tray Acoustic Noise..... | 175 |
| CE4900 Controller-Drive Tray Site Wiring and Power..... | 175 |
| CE4900 Controller-Drive Tray Power Input..... | 176 |
| CE4900 Controller-Drive Tray Power Factor Correction..... | 176 |
| CE4900 Controller-Drive Tray AC Power Cords and Receptacles..... | 176 |
| CE4900 Controller-Drive Tray Optional DC Power Connector Cables and Source Wires..... | 177 |
| Preparing the Network for the Controllers..... | 177 |
| Specifications of the CDE3994 Controller-Drive Tray..... | 179 |
| CDE3994 Controller-Drive Tray Dimensions..... | 180 |
| CDE3994 Controller-Drive Tray Weight..... | 181 |
| CDE3994 Controller-Drive Tray Shipping Dimensions..... | 182 |
| CDE3994 Controller-Drive Tray Temperature and Humidity..... | 182 |
| CDE3994 Controller-Drive Tray Altitude Ranges..... | 183 |
| CDE3994 Controller-Drive Tray Airflow and Heat Dissipation..... | 183 |
| CDE3994 Controller-Drive Tray Acoustic Noise..... | 184 |

| | |
|---|-----|
| CDE3994 Controller-Drive Tray Site Wiring and Power..... | 184 |
| CDE3994 Controller-Drive Tray Power Input..... | 185 |
| CDE3994 Controller-Drive Tray Power Factor Correction..... | 185 |
| CDE3994 Controller-Drive Tray AC Power Cords and Receptacles..... | 185 |
| CDE3994 Controller-Drive Tray Optional DC Power Connector Cables and Source Wires..... | 186 |
| Preparing the Network for the Controllers..... | 186 |
| Specifications of the AM1331 and AM1333 Controller-Drive Trays..... | 188 |
| AM1331and AM1333 Controller-Drive Tray Dimensions..... | 189 |
| AM1331 and AM1333 Controller-Drive Trays Weight..... | 189 |
| AM1331 and AM1333 Controller-Drive Trays Shipping Dimensions..... | 190 |
| AM1331 and AM1333 Controller-Drive Trays Temperature and Humidity..... | 190 |
| AM1331 and AM1333 Controller-Drive Trays Altitude Ranges..... | 191 |
| AM1331 and AM1333 Controller-Drive Trays Airflow and Heat Dissipation..... | 191 |
| AM1331 and AM1333 Controller-Drive Trays Acoustic Noise..... | 192 |
| AM1331 and AM1333 Controller-Drive Trays Site Wiring and Power..... | 192 |
| AM1331 and AM1333 Controller-Drive Trays Power Input..... | 193 |
| AM1331 and AM1333 Controller-Drive Trays Power Factor Correction..... | 194 |
| AM1331 and AM1333 Controller-Drive Trays AC Power Cords and Receptacles..... | 194 |
| AM1331 and AM1333 Controller-Drive Trays Optional DC Power Connector Cables and Source Wires..... | 194 |
| Preparing the Network for the Controllers..... | 195 |
| Specifications of the AM1532 Controller-Drive Tray..... | 196 |
| AM1532 Controller-Drive Tray Dimensions..... | 197 |
| AM1532 Controller-Drive Tray Weight..... | 197 |
| AM1532 Controller-Drive Tray Shipping Dimensions..... | 198 |
| AM1532 Controller-Drive Tray Temperature and Humidity..... | 198 |
| AM1532 Controller-Drive Tray Altitude Ranges..... | 198 |
| AM1532 Controller-Drive Tray Airflow and Heat Dissipation..... | 199 |
| AM1532 Controller-Drive Tray Acoustic Noise..... | 199 |
| AM1532 Controller-Drive Tray Site Wiring and Power..... | 200 |
| AM1532 Controller-Drive Tray Power Input..... | 200 |
| AM1532 Controller-Drive Tray Power Factor Correction..... | 201 |
| AM1532 Controller-Drive Tray AC Power Cords and Receptacles..... | 201 |
| AM1532 Controller-Drive Tray Optional DC Power Connector Cables and Source Wires..... | 201 |
| Preparing the Network for the Controllers..... | 202 |
| Specifications of the AM1932 Controller-Drive Tray..... | 203 |
| AM1932 Controller-Drive Tray Dimensions..... | 203 |
| AM1932 Controller-Drive Tray Weight..... | 204 |
| AM1932 Controller-Drive Tray Shipping Dimensions..... | 205 |
| AM1932 Controller-Drive Tray Temperature and Humidity..... | 205 |
| AM1932 Controller-Drive Tray Altitude Ranges..... | 205 |
| AM1932 Controller-Drive Tray Airflow and Heat Dissipation..... | 206 |
| AM1932 Controller-Drive Tray Acoustic Noise..... | 206 |
| AM1932 Controller-Drive Tray Site Wiring and Power..... | 207 |
| AM1932 Controller-Drive Tray Power Input..... | 207 |
| AM1932 Controller-Drive Tray Power Factor Correction..... | 208 |
| AM1932 Controller-Drive Tray AC Power Cords and Receptacles..... | 208 |
| AM1932 Controller-Drive Tray Optional DC Power Connector Cables and Source Wires..... | 208 |
| Preparing the Network for the Controllers..... | 209 |
| Specifications of the DE1600 Drive Tray..... | 210 |
| DE1600 Drive Tray Dimensions..... | 211 |
| DE1600 Drive Tray Weight..... | 211 |
| DE1600 Drive Tray Shipping Dimensions..... | 212 |
| DE1600 Drive Tray Temperature and Humidity..... | 212 |
| DE1600 Drive Tray Altitude Ranges..... | 213 |

| | |
|--|-----|
| DE1600 Drive Tray Airflow and Heat Dissipation..... | 213 |
| DE1600 Drive Tray Acoustic Noise..... | 214 |
| DE1600 Drive Tray Site Wiring and Power..... | 214 |
| DE1600 Drive Tray Power Input..... | 215 |
| DE1600 Drive Tray Power Factor Correction..... | 216 |
| DE1600 Drive Tray AC Power Cords and Receptacles..... | 216 |
| DE1600 Drive Tray Optional DC Power Connector Cables and Source Wires..... | 216 |
| Specifications of the DE5600 Drive Tray..... | 218 |
| DE5600 Drive Tray Dimensions..... | 219 |
| DE5600 Drive Tray Weight..... | 220 |
| DE5600 Drive Tray Shipping Dimensions..... | 220 |
| DE5600 Drive Tray Temperature and Humidity..... | 220 |
| DE5600 Drive Tray Altitude Ranges..... | 221 |
| DE5600 Drive Tray Airflow and Heat Dissipation..... | 221 |
| DE5600 Drive Tray Acoustic Noise..... | 222 |
| DE5600 Drive Tray Site Wiring and Power..... | 222 |
| DE5600 Drive Tray AC Power Input..... | 223 |
| DE5600 Drive Tray Power Factor Correction..... | 224 |
| DE5600 Drive Tray AC Power Cords and Receptacles..... | 224 |
| DE5600 Drive Tray Optional DC Power Connector Cables and Source Wires..... | 224 |
| Specifications of the DE6600 Drive Tray..... | 226 |
| DE6600 Drive Tray Dimensions..... | 227 |
| DE6600 Drive Tray Weight..... | 228 |
| DE6600 Drive Tray Shipping Dimensions..... | 229 |
| DE6600 Drive Tray Temperature and Humidity..... | 229 |
| DE6600 Drive Tray Altitude Ranges..... | 229 |
| DE6600 Drive Tray Airflow and Heat Dissipation..... | 230 |
| DE6600 Drive Tray Acoustic Noise..... | 231 |
| DE6600 Drive Tray Site Wiring and Power..... | 231 |
| DE6600 Drive Tray Power Input..... | 231 |
| DE6600 Drive Tray Power Factor Correction..... | 232 |
| DE6600 Drive Tray AC Power Cords and Receptacles..... | 232 |
| Specifications of the DE6900 Drive Tray..... | 233 |
| DE6900 Drive Tray Dimensions..... | 234 |
| DE6900 Drive Tray Weight..... | 234 |
| DE6900 Drive Tray Shipping Dimensions..... | 235 |
| DE6900 Drive Tray Temperature and Humidity..... | 235 |
| DE6900 Drive Tray Altitude Ranges..... | 236 |
| DE6900 Drive Tray Airflow and Heat Dissipation..... | 236 |
| DE6900 Drive Tray Acoustic Noise..... | 237 |
| DE6900 Drive Tray Site Wiring and Power..... | 238 |
| DE6900 Drive Tray Power Input..... | 238 |
| DE6900 Drive Tray Power Factor Correction..... | 238 |
| DE6900 Drive Tray AC Power Cords and Receptacles..... | 239 |
| Specifications of the FC4600 Drive Tray..... | 240 |
| FC4600 Drive Tray Dimensions..... | 241 |
| FC4600 Drive Tray Weight..... | 242 |
| FC4600 Drive Tray Shipping Dimensions..... | 243 |
| FC4600 Drive Tray Temperature and Humidity..... | 243 |
| FC4600 Drive Tray Altitude Ranges..... | 244 |
| FC4600 Drive Tray Airflow and Heat Dissipation..... | 244 |
| FC4600 Drive Tray Acoustic Noise..... | 245 |
| FC4600 Drive Tray Site Wiring and Power..... | 245 |
| FC4600 Drive Tray Power Input..... | 246 |

| | |
|--|------------|
| FC4600 Drive Tray Power Factor Correction..... | 246 |
| FC4600 Drive Tray AC Power Cords and Receptacles..... | 246 |
| FC4600 Drive Tray Optional DC Power Connector Cables and Source Wires..... | 246 |
| Specifications of the AT2655 Drive Tray..... | 248 |
| AT2655 Drive Tray Dimensions..... | 248 |
| AT2655 Drive Tray Weight..... | 249 |
| AT2655 Drive Tray Shipping Dimensions..... | 250 |
| AT2655 Drive Tray Temperature and Humidity..... | 250 |
| AT2655 Drive Tray Altitude Ranges..... | 251 |
| AT2655 Drive Tray Airflow and Heat Dissipation..... | 251 |
| AT2655 Drive Tray Acoustic Noise..... | 252 |
| AT2655 Drive Tray Site Wiring and Power..... | 252 |
| AT2655 Drive Tray Power Input..... | 253 |
| AT2655 Drive Tray Power Factor Correction..... | 253 |
| AT2655 Drive Tray Power Cords and Receptacles..... | 253 |
| Specifications of the FC2610 Drive Tray..... | 254 |
| FC2610 Drive Tray Dimensions..... | 254 |
| FC2610 Drive Tray Weight..... | 255 |
| FC2610 Drive Tray Shipping Dimensions..... | 256 |
| FC2610 Drive Tray Temperature and Humidity..... | 256 |
| FC2610 Drive Tray Altitude Ranges..... | 257 |
| FC2610 Drive Tray Airflow and Heat Dissipation..... | 257 |
| FC2610 Drive Tray Acoustic Noise..... | 258 |
| FC2610 Drive Tray Site Wiring and Power..... | 259 |
| FC2610 Drive Tray Power Input..... | 259 |
| FC2610 Drive Tray Power Factor Correction..... | 259 |
| FC2610 Drive Tray Power Cords and Receptacles..... | 260 |
| Specifications of the FC2600 Drive Tray..... | 261 |
| FC2600 Drive Tray Dimensions..... | 262 |
| FC2600 Drive Tray Weight..... | 262 |
| FC2600 Drive Tray Temperature and Humidity..... | 263 |
| FC2600 Drive Tray Altitude Ranges..... | 263 |
| FC2600 Drive Tray Airflow and Heat Dissipation..... | 264 |
| FC2600 Drive Tray Acoustic Noise..... | 265 |
| FC2600 Drive Tray Site Wiring and Power..... | 265 |
| FC2600 Drive Tray Power Input..... | 265 |
| FC2600 Drive Tray Power Correction Factor..... | 266 |
| FC2600 Drive Tray AC Power Cords and Receptacles..... | 266 |
| Specifications of the DM1300 Drive Tray..... | 267 |
| DM1300 Drive Tray Dimensions..... | 268 |
| DM1300 Drive Tray Weight..... | 268 |
| DM1300 Drive Tray Shipping Dimensions..... | 269 |
| DM1300 Drive Tray Temperature and Humidity..... | 269 |
| DM1300 Drive Tray Altitude Ranges..... | 269 |
| DM1300 Drive Tray Airflow and Heat Dissipation..... | 270 |
| DM1300 Drive Tray Acoustic Noise..... | 271 |
| DM1300 Drive Tray Site Wiring and Power..... | 271 |
| DM1300 Drive Tray Power Input..... | 271 |
| DM1300 Drive Tray Power Factor Correction..... | 272 |
| DM1300 Drive Tray AC Power Cords and Receptacles..... | 272 |
| DM1300 Drive Tray Optional DC Power Connector Cables and Source Wires..... | 272 |
| Regulatory Compliance Statements..... | 274 |
| CDE2600 Controller-Drive Tray Installation..... | 276 |

| | |
|---|-----|
| Step 1 – Preparing for a CDE2600 Controller-Drive Tray Installation..... | 277 |
| Key Terms..... | 278 |
| Gathering Items..... | 278 |
| Basic Hardware..... | 279 |
| CDE2600 Configuration Cables and Connectors..... | 280 |
| Product DVDs..... | 282 |
| Tools and Other Items..... | 283 |
| Things to Know – SFP Transceivers, Fiber-Optic Cables, Copper Cables, and SAS Cables..... | 284 |
| Things to Know – Taking a Quick Glance at the Hardware in a CDE2600 Controller-Drive Tray Configuration..... | 285 |
| For Additional Information on the CDE2600 Controller-Drive Tray Configuration..... | 294 |
| Step 2 – Installing and Configuring the Switches..... | 295 |
| Things to Know – Switches..... | 295 |
| Procedure – Installing and Configuring Switches..... | 297 |
| Step 3 – Installing the Host Bus Adapters for the CDE2600 Controller-Drive Tray..... | 299 |
| Key Terms..... | 299 |
| Things to Know – Host Bus Adapters and Ethernet Network Interface Cards..... | 299 |
| Procedure – Installing Host Bus Adapters..... | 299 |
| Step 4 – Installing the CDE2600 Controller-Drive Tray..... | 301 |
| Things to Know – General Installation..... | 301 |
| Procedure – Installing the CDE2600 Controller-Drive Tray..... | 301 |
| Step 5 – Connecting the CDE2600 Controller-Drive Tray to the Hosts..... | 305 |
| Key Terms..... | 305 |
| Things to Know – Host Channels..... | 305 |
| Procedure – Connecting Host Cables on a CDE2600 Controller-Drive Tray..... | 306 |
| Step 6 – Installing the Drive Trays for the CDE2600 Controller-Drive Tray Configurations..... | 313 |
| Things to Know – General Installation of Drive Trays with the CDE2600 Controller-Drive Tray..... | 313 |
| For Additional Information on Drive Tray Installation..... | 313 |
| Procedure – Installing the DE1600 Drive Trays and the DE5600 Drive Trays..... | 313 |
| Procedure – Installing Drives in the DE1600 Drive Trays and the DE5600 Drive Trays..... | 322 |
| Step 7 – Connecting the CDE2600 Controller-Drive Tray to the Drive Trays..... | 324 |
| Key Terms..... | 324 |
| Things to Know – CDE2600 Controller-Drive Tray..... | 324 |
| Things to Know – Drive Trays with the CDE2600 Controller-Drive Tray..... | 324 |
| Things to Know – Drive Tray Cabling Configurations – Simplex System..... | 325 |
| Things to Know – Drive Tray Cabling Configurations – Duplex System..... | 325 |
| Procedure – Connecting the DE1600 Drive Trays and the DE5600 Drive Trays..... | 328 |
| Step 8 – Connecting the Ethernet Cables..... | 331 |
| Key Terms..... | 331 |
| Things to Know – Connecting Ethernet Cables..... | 331 |
| Procedure – Connecting Ethernet Cables..... | 331 |
| Step 9 – Connecting the Power Cords..... | 332 |
| Things to Know – AC Power Cords..... | 332 |
| Things to Know – DC Power Cords..... | 332 |
| Procedure – Connecting AC Power Cords..... | 333 |
| Procedure – Connecting DC Power Cords..... | 333 |
| Step 10 – Turning on the Power and Checking for Problems in a CDE2600 Controller-Drive Tray Configuration..... | 334 |
| Procedure – Turning On the Power to the Storage Array and Checking for Problems in a CDE2600 Controller-Drive Tray Configuration..... | 334 |
| Things to Know – LEDs on the CDE2600 Controller-Drive Tray..... | 334 |
| Things to Know – General Behavior of the LEDs on the CDE2600 Controller-Drive Tray..... | 342 |
| Things to Know – LEDs on the DE1600 Drive Tray and the DE5600 Drive Tray..... | 345 |

| | |
|---|------------|
| General Behavior of the LEDs on the DE1600 Drive Tray, and the DE5600 Drive Tray..... | 350 |
| Things to Know – Service Action Allowed LEDs..... | 351 |
| Things to Know – Sequence Code Definitions for the CDE2600 Controller-Drive Tray..... | 352 |
| Things to Know – Lock-Down Codes for the CDE2600 Controller-Drive Tray..... | 353 |
| Things to Know – Diagnostic Code Sequences for the CDE2600 Controller-Drive Tray..... | 354 |
| Things to Know – Seven-Segment Display for the DE1600 Drive Tray and the DE5600 Drive Tray..... | 356 |
| CDE2600-60 Controller-Drive Tray Installation..... | 358 |
| Step 1 – Preparing for a CDE2600-60 Controller-Drive Tray Installation..... | 359 |
| Key Terms..... | 359 |
| Gathering Items..... | 360 |
| Basic Hardware..... | 360 |
| CDE2600 Configuration Cables and Connectors..... | 361 |
| Product DVDs..... | 364 |
| Tools and Other Items..... | 364 |
| Things to Know – SFP Transceivers, Fiber-Optic Cables, Copper Cables, and SAS Cables..... | 365 |
| Things to Know – Taking a Quick Glance at the Hardware in a CDE2600-60 Controller-Drive Tray Configuration..... | 367 |
| For Additional Information on the CDE2600-60 Controller-Drive Tray Configuration..... | 373 |
| Step 2 – Installing and Configuring the Switches..... | 374 |
| Things to Know – Switches..... | 374 |
| Procedure – Installing and Configuring Switches..... | 376 |
| Step 3 – Installing the Host Bus Adapters for the CDE2600 Controller-Drive Tray..... | 378 |
| Key Terms..... | 378 |
| Things to Know – Host Bus Adapters and Ethernet Network Interface Cards..... | 378 |
| Procedure – Installing Host Bus Adapters..... | 378 |
| Step 4 – Installing the CDE2600 Controller-Drive Tray..... | 380 |
| Things to Know – General Installation..... | 380 |
| Steps to Install – CDE2600-60 Controller-Drive Tray..... | 380 |
| Step 5 – Connecting the CDE2600 Controller-Drive Tray to the Hosts..... | 391 |
| Key Terms..... | 391 |
| Things to Know – Host Channels on the CDE2600-60 Controller-Drive Tray..... | 391 |
| Procedure – Connecting Host Cables on a CDE2600-60 Controller-Drive Tray..... | 392 |
| Step 6 – Installing the Drive Trays for the CDE2600-60 Controller-Drive Tray Configurations..... | 399 |
| Things to Know – General Installation of Drive Trays with the CDE2600-60 Controller-Drive Tray..... | 399 |
| Steps to Install – DE6600 Drive Tray..... | 399 |
| Steps to Install – Drives on the DE6600 Drive Tray..... | 409 |
| Step 7 – Connecting the CDE2600-60 Controller-Drive Tray to the Drive Trays..... | 413 |
| Key Terms..... | 413 |
| Things to Know – CDE2600-60 Controller-Drive Tray..... | 413 |
| Things to Know – Drive Trays with the CDE2600-60 Controller-Drive Tray..... | 414 |
| Things to Know – CDE2600-60 Drive Tray Cabling Configurations – Duplex System..... | 414 |
| Procedure – Connecting the DE6600 Drive Tray..... | 416 |
| Step 8 – Connecting the Ethernet Cables..... | 419 |
| Key Terms..... | 419 |
| Things to Know – Connecting Ethernet Cables..... | 419 |
| Procedure – Connecting Ethernet Cables..... | 419 |
| Step 9 – Connecting the Power Cords..... | 420 |
| Things to Know – AC Power Cords..... | 420 |
| Procedure – Connecting AC Power Cords..... | 420 |
| Step 10 – Turning on the Power and Checking for Problems in a CDE2600-60 Controller-Drive Tray Configuration..... | 421 |

| | |
|--|------------|
| Procedure – Turning On the Power to the Storage Array and Checking for Problems in a CDE2600-60 Controller-Drive Tray Configuration..... | 421 |
| Things to Know – LEDs on the CDE2600-60 Controller-Drive Tray..... | 421 |
| Things to Know – General Behavior of the LEDs on the CDE2600 Controller-Drive Tray..... | 427 |
| LEDs on the DE6600 Drive Tray..... | 430 |
| LEDs on the DE6600 Drive Drawers..... | 434 |
| LEDs on the DE6600 Drives..... | 435 |
| General Behavior of the LEDs on the DE6600 Drive Tray..... | 436 |
| Things to Know – Service Action Allowed LEDs..... | 437 |
| Things to Know – Sequence Code Definitions for the CDE2600-60 Controller-Drive Tray..... | 438 |
| Things to Know – Lock-Down Codes for the CDE2600-60 Controller-Drive Tray..... | 439 |
| Things to Know – Diagnostic Code Sequences for the CDE2600-60 Controller-Drive Tray..... | 440 |
| Supported Diagnostic Codes for the DE6600 Drive Tray on the Seven-Segment Display..... | 442 |
| CE5400 Controller-Drive Tray Installation..... | 444 |
| Step 1 – Preparing for a CE5400 Controller-Drive Tray Installation..... | 445 |
| Key Terms..... | 446 |
| Gathering Items..... | 447 |
| Basic Hardware..... | 447 |
| CE5400 Configuration Cables and Connectors..... | 448 |
| Product DVDs..... | 450 |
| Tools and Other Items..... | 450 |
| Things to Know – Cables and SFP Transceivers..... | 451 |
| Things to Know – Taking a Quick Glance at the Hardware in CE5400 Controller-Drive Tray Configurations..... | 453 |
| For Additional Information on the CE5400 Controller-Drive Tray Configuration..... | 461 |
| Step 2 – Installing and Configuring the Switches..... | 462 |
| Things to Know – Switches..... | 462 |
| Procedure – Installing and Configuring Switches..... | 463 |
| Step 3 – Installing the Host Bus Adapters for the CE5400 Controller-Drive Trays..... | 465 |
| Key Terms..... | 465 |
| Things to Know – Host Bus Adapters..... | 465 |
| Procedure – Installing Host Bus Adapters..... | 465 |
| Step 4 – Installing the CE5400 Controller-Drive Tray..... | 467 |
| Things to Know – General Installation..... | 467 |
| Procedure – Installing the CE5400-24 Controller-Drive Tray or the CE5400-12 Controller-Drive Tray..... | 467 |
| Procedure – Installing the CE5400-60 Controller-Drive Tray..... | 470 |
| Step 5 – Connecting the CE5400 Controller-Drive Tray to the Hosts..... | 481 |
| Key Terms..... | 481 |
| Things to Know – Host Channels..... | 481 |
| Procedure – Connecting Host Cables on a CE5400 Controller-Drive Tray..... | 482 |
| Step 6 – Installing the Drive Trays for the CE5400 Controller-Drive Tray Configurations..... | 485 |
| Things to Know – General Installation of Drive Trays..... | 485 |
| For Additional Information on Drive Tray Installation..... | 485 |
| Procedure – Installing the DE1600 Drive Trays and the DE5600 Drive Trays..... | 485 |
| Procedure – Installing the DE6600 Drive Trays..... | 494 |
| Procedure – Installing the Drives in the DE6600 Drive Tray..... | 504 |
| Procedure – Installing Drives in the DE1600 Drive Trays and the DE5600 Drive Trays..... | 508 |
| Step 7 – Connecting the CE5400 Controller-Drive Tray to the Drive Trays..... | 510 |
| Key Terms..... | 510 |
| Things to Know – CE5400 Controller-Drive Tray..... | 510 |
| Things to Know – Drive Trays with the CE5400 Controller-Drive Tray..... | 511 |
| Things to Know – Drive Tray Cabling Configurations for the CE5400-24 Controller-Drive Tray and the CE5400-24 Controller-Drive Tray..... | 512 |

| | |
|--|------------|
| Things to Know – Drive Tray Cabling Configurations for the CE5400-60 Controller-Drive Tray..... | 515 |
| Procedure – Connecting the Drive Trays to the CE5400 Controller-Drive Tray..... | 520 |
| Step 8 – Connecting the Ethernet Cables..... | 522 |
| Key Terms..... | 522 |
| Things to Know – Connecting Ethernet Cables..... | 522 |
| Procedure – Connecting Ethernet Cables..... | 522 |
| Step 9 – Connecting the Power Cords..... | 523 |
| Things to Know – AC Power Cords..... | 523 |
| Things to Know – DC Power Cords..... | 523 |
| Procedure – Connecting AC Power Cords..... | 524 |
| Procedure – Connecting DC Power Cords..... | 524 |
| Step 10 – Turning on the Power and Checking for Problems in a CE5400 Controller-Drive Tray Configuration..... | 525 |
| Procedure – Turning On the Power to the Storage Array and Checking for Problems in a CE5400 Controller-Drive Tray Configuration..... | 525 |
| Things to Know – Service Action Allowed LEDs..... | 525 |
| Things to Know – LEDs on the CE5400 Controller-Drive Trays..... | 526 |
| Things to Know – General Behavior of the LEDs on the CE5400 Controller-Drive Trays..... | 536 |
| Things to Know – Sequence Code Definitions for the CE5400 Controller-Drive Trays..... | 539 |
| Things to Know – Lock-Down Codes for the CE5400 Controller-Drive Trays..... | 541 |
| Things to Know – Diagnostic Code Sequences for the CE5400 Controller-Drive Trays..... | 542 |
| Things to Know – LEDs on the DE1600 Drive Tray and the DE5600 Drive Tray..... | 544 |
| Things to Know – LEDs on the DE6600 Drive Tray..... | 549 |
| Things to Know – General Behavior of the LEDs on the DE1600 Drive Tray, the DE5600 Drive Tray, and the DE6600 Drive Tray..... | 555 |
| Things to Know – Seven-Segment Display for the DE1600 Drive Tray and the DE5600 Drive Tray..... | 556 |
| CE7900 Controller Tray Installation..... | 558 |
| Step 1 – Preparing for a CE7900 Controller Tray Installation..... | 559 |
| Key Terms..... | 559 |
| Gathering Items..... | 559 |
| Basic Hardware for CE7900 Configurations..... | 560 |
| Cables and Connectors for a CE7900 Controller Tray Configuration..... | 561 |
| Product DVDs..... | 562 |
| Tools and Other Items..... | 562 |
| Things to Know – SFP Transceivers, Fiber-Optic Cables, and Copper Cables..... | 563 |
| Things to Know – Taking a Quick Glance at the CE7900 Configuration Hardware..... | 565 |
| For Additional Information on the CE7900 Controller-Drive Tray Configuration..... | 569 |
| Step 2 – Installing and Configuring the Switches..... | 570 |
| Things to Know – Switches..... | 570 |
| Procedure – Installing and Configuring Switches..... | 572 |
| Step 3 – Installing the Host Bus Adapters for the CE7900 Controller Tray..... | 574 |
| Key Terms..... | 574 |
| Things to Know – Host Adapters..... | 574 |
| Procedure – Installing Host Bus Adapters..... | 575 |
| Step 4 – Installing the Controller Tray..... | 577 |
| Things to Know – General Installation..... | 577 |
| Steps to Install – CE7900 Controller Tray..... | 577 |
| Step 5 – Connecting the Controller Tray to the Hosts..... | 580 |
| Key Terms..... | 580 |
| Things to Know – Host Channels on the CE7900 Controller Tray..... | 581 |
| Things to Know – Host Interface Cards..... | 581 |
| Procedure – Connecting Host Cables on the CE7900 Controller Tray..... | 582 |

| | |
|--|------------|
| Step 6 – Installing the Drive Trays for the CE7900 Controller Tray Configurations..... | 586 |
| Things to Know – General Installation of the CE7900 Controller Tray..... | 586 |
| Things to Know – General Installation of the FC4600 Drive Tray..... | 586 |
| Things to Know – General Installation of the DE6900 Drive Tray..... | 586 |
| For Additional Information on Drive Tray Installation..... | 587 |
| Procedure – Installing the FC4600 Drive Tray..... | 587 |
| Procedure – Installing Drives for the FC4600 Drive Tray..... | 592 |
| Things to Know – Link Rate Switch on the FC4600 Drive Tray..... | 593 |
| Procedure – Setting the Link Rate Switch on the FC4600 Drive Tray..... | 594 |
| Steps to Install – DE6900 Drive Tray..... | 595 |
| Procedure – Installing Drives in the DE6900 Drive Tray..... | 603 |
| Step 7 – Connecting the Controller Tray to the Drive Trays..... | 606 |
| Key Terms..... | 606 |
| Things to Know – CE7900 Controller Tray..... | 606 |
| Things to Know – DE6900 Drive Tray..... | 607 |
| Things to Know – FC4600 Drive Tray..... | 608 |
| Things to Know – Mixing Drive Tray Types..... | 609 |
| Things to Know – Connecting the Drive Trays..... | 609 |
| Procedure – Connecting DE6900 Drive Trays and FC4600 Drive Trays to the CE7900 Controller Tray..... | 609 |
| Step 8 – Connecting the Ethernet Cables..... | 621 |
| Key Terms..... | 621 |
| Things to Know – Connecting Ethernet Cables..... | 621 |
| Procedure – Connecting Ethernet Cables..... | 621 |
| Step 9 – Connecting the Power Cords in a CE7900 Controller Tray Configuration..... | 622 |
| Things to Know – AC Power Cords..... | 622 |
| Procedure – Connecting AC Power Cords..... | 622 |
| Step 10 – Turning on the Power and Checking for Problems in a CE7900 Controller Tray Configuration..... | 623 |
| Procedure – Turning on the Power to the Storage Array and Checking for Problems..... | 623 |
| Things to Know – LEDs on the CE7900 Controller Tray..... | 623 |
| Things to Know – Service Action Allowed LED..... | 626 |
| General Behavior of the LEDs on the Drive Trays..... | 627 |
| Service Action LEDs on the Drive Tray..... | 628 |
| Things to Know – LEDs on the DE6900 Drive Tray..... | 628 |
| LEDs on the DE6900 Drive Tray..... | 629 |
| LEDs on the Drive Drawers..... | 632 |
| LEDs on the DE6900 Drives..... | 633 |
| Things to Know – LEDs on the FC4600 Drive Tray..... | 634 |
| LEDs on the FC4600 Drive Tray..... | 634 |
| LEDs on the FC4600 Drives..... | 637 |
| Supported Diagnostic Codes on the Seven-Segment Display for the DE6900 Drive Tray and the FC4600 Drive Tray..... | 637 |
| CDE4900 Controller-Drive Tray Installation..... | 640 |
| Step 1 – Preparing for an Installation..... | 641 |
| Key Terms..... | 641 |
| Gathering Items..... | 641 |
| Basic Hardware..... | 642 |
| Cables and Connectors on the CDE4900 Controller-Drive Tray Configuration..... | 643 |
| Product DVDs..... | 645 |
| Tools and Other Items..... | 645 |
| Things to Know – SFP Transceivers, Fiber-Optic Cables, Copper Cables, and SAS Cables..... | 646 |
| Things to Know – Taking a Quick Glance at the Hardware..... | 647 |
| For Additional Information..... | 651 |
| Step 2 – Installing and Configuring the Switches..... | 652 |

| | |
|---|------------|
| Things to Know – Switches..... | 652 |
| Procedure – Installing and Configuring Switches..... | 654 |
| Step 3 – Installing the Host Bus Adapters for the CDE4900 Controller-Drive Tray Configuration..... | 656 |
| Key Terms..... | 656 |
| Things to Know – Host Bus Adapters and Ethernet Network Interface Cards..... | 656 |
| Procedure – Installing Host Bus Adapters..... | 656 |
| Step 4 – Installing the CDE4900 Controller-Drive Tray..... | 658 |
| Things to Know – General Installation..... | 658 |
| Procedure – Installing the CDE4900 Controller-Drive Tray..... | 658 |
| Step 5 – Connecting the CDE4900 Controller-Drive Tray to the Hosts..... | 661 |
| Key Terms..... | 661 |
| Things to Know – Host Channels..... | 661 |
| Procedure – Connecting Host Cables..... | 662 |
| Step 6 – Installing the Drive Trays for the CDE4900 Controller-Drive Tray Configurations..... | 666 |
| Things to Know – General Installation..... | 666 |
| For Additional Information on Drive Tray Installation..... | 666 |
| Procedure – Installing the FC4600 Drive Tray..... | 666 |
| Things to Know – Adding Drive Trays to an Existing Storage Array..... | 671 |
| Things to Know – Link Rate Switch on the FC4600 Drive Tray..... | 672 |
| Procedure – Setting the Link Rate Switch on the FC4600 Drive Tray..... | 673 |
| Step 7 – Connecting the CDE4900 Controller-Drive Tray to the Drive Trays..... | 674 |
| Key Terms..... | 674 |
| Things to Know – CDE4900 Controller-Drive Tray..... | 674 |
| Procedure – Cabling a Drive Tray to a Storage Array with Power but No I/O Activity..... | 675 |
| Procedure – Cabling a Drive Tray to a Storage Array with No Power and No I/O Activity..... | 676 |
| Step 8 – Connecting the Ethernet Cables..... | 678 |
| Key Terms..... | 678 |
| Things to Know – Connecting Ethernet Cables..... | 678 |
| Procedure – Connecting Ethernet Cables..... | 678 |
| Step 9 – Connecting the Power Cords in a CDE4900 Controller-Drive Tray Configuration..... | 679 |
| Things to Know – AC Power Cords..... | 679 |
| Things to Know – DC Power Cords..... | 679 |
| Procedure – Connecting AC Power Cords..... | 680 |
| Procedure – Connecting DC Power Cords..... | 680 |
| Step 10 – Turning on the Power and Checking for Problems in a CDE4900 Controller-Drive Tray Configuration..... | 681 |
| Procedure – Turning On the Power to the Storage Array and Checking for Problems in a CDE4900 Controller-Drive Tray Configuration..... | 681 |
| Things to Know – LEDs on the Controller-Drive Tray..... | 681 |
| General Behavior of the LEDs on the Drive Trays..... | 685 |
| LEDs on the FC4600 Drive Tray..... | 686 |
| LEDs on the FC4600 Drives..... | 689 |
| Things to Know – Service Action Allowed LEDs..... | 689 |
| Hardware Cabling..... | 691 |
| Cabling Concepts and Best Practices..... | 692 |
| Cabling Concepts..... | 692 |
| Fabric (Switched) Topologies Compared to Direct-Attach Topologies..... | 692 |
| Drive Tray..... | 692 |
| Controller Tray..... | 693 |
| Controller-Drive Tray..... | 693 |
| Host Channels and Drive Channels..... | 693 |
| Host Ports and Drive Ports..... | 694 |

| | |
|--|-----|
| Dual-Ported Drives..... | 694 |
| Preferred Controllers and Alternate Controllers..... | 694 |
| Alternate Path Software..... | 694 |
| Failover..... | 695 |
| Redundant and Non-Redundant..... | 695 |
| Single Point of Failure..... | 695 |
| SFP Transceivers, Fiber-Optic Cables, and Copper Cables..... | 695 |
| Host Adapters..... | 696 |
| Host Interface Cards..... | 696 |
| Network Interface Cards..... | 697 |
| Switches and Zoning..... | 697 |
| In-Band Management and Out-of-Band Management..... | 698 |
| Best Practices..... | 699 |
| Drive Cabling for Redundancy..... | 700 |
| Host Cabling for Redundancy..... | 701 |
| Host Cabling for Remote Volume Mirroring..... | 701 |
| Cabling for Performance..... | 701 |
| Fibre Channel Drive-Side Trunking..... | 701 |
| Considerations for Drive Channel Speed..... | 702 |
| Multiple Types of Drive Trays..... | 702 |
| Single-Controller Topologies and Dual-Controller Topologies..... | 705 |
| Copper Cables and Fiber-Optic Cables..... | 705 |
| Cabling for Drive Trays That Support Loop Switch Technology..... | 706 |
| Labeling Cables..... | 707 |
| Cabling Information Provided by SANtricity ES Storage Manager..... | 707 |
| Adding New Drive Trays to an Existing Storage Array..... | 708 |
| Common Procedures..... | 708 |
| Handling Static-Sensitive Components..... | 708 |
| Installing an SFP Transceiver and a Fiber-Optic Cable..... | 708 |
| Installing a Copper Cable with a Passive SFP Transceiver..... | 709 |
| Installing an iSCSI Cable..... | 710 |
| Installing a SAS Cable..... | 710 |
| Product Compatibility..... | 712 |
| Host Channel Information by Model..... | 712 |
| Drive Channel Information by Model..... | 713 |
| Drive Tray Information by Model..... | 715 |
| Host Cabling..... | 718 |
| Host Interface Connections..... | 718 |
| Maximum Number of Host Connections..... | 720 |
| Direct-Attach Topologies..... | 720 |
| One Host to a Controller Tray or a Controller-Drive Tray..... | 720 |
| Two Hosts to a Controller Tray or a Controller-Drive Tray..... | 721 |
| One Hosts with Direct SAS Connections to Four Controller-Drive Trays..... | 722 |
| One Single-HBA Host to a Single-Controller Controller Tray or a Single-Controller Controller-Drive Tray..... | 723 |
| Switch Topologies..... | 724 |
| One Host to a Controller Tray or a Controller-Drive Tray..... | 724 |
| Two Hosts to a Controller Tray or a Controller-Drive Tray..... | 725 |
| Two Hosts to a Controller-Drive Tray with Switched SAS Connections..... | 726 |
| Four Hosts to a Controller Tray or a Controller-Drive Tray..... | 728 |
| Mixed Topologies..... | 729 |
| Drive Cabling..... | 731 |
| Drive Channel Redundancy for the CE7900 Controller Tray and the CE7922 Controller Tray..... | 731 |
| Drive Channel Redundancy for the CE6998 Controller Tray..... | 732 |
| Drive Channel Redundancy for the CE5400-60 Controller-Drive Tray..... | 733 |

| | |
|---|-----|
| Drive Channel Redundancy for the CE5400-12 Controller-Drive Tray and the CE5400-24 Controller-Drive Tray..... | 733 |
| Drive Channel Redundancy for the CE4900 Controller-Drive Tray..... | 734 |
| Drive Channel Redundancy for the CDE3994 Controller-Drive Tray and the CDE3992 Controller-Drive Tray..... | 735 |
| Drive Channel Redundancy for the CE2600 Controller-Drive Tray..... | 735 |
| Drive Channel Redundancy for the CE2600-60 Controller-Drive Tray..... | 736 |
| ESM Canister Arrangements..... | 736 |
| Drive Cabling Topologies for the CE7900 Controller Tray and the CE7922 Controller Tray..... | 737 |
| Cabling for the CE7922 Controller Tray or the CE7900 Controller Tray and One to Four FC4600 Drive Trays..... | 738 |
| Cabling for the CE7922 Controller Tray or the CE7900 Controller Tray and Five to Eight FC4600 Drive Trays..... | 739 |
| One CE7922 Controller Tray or CE7900 Controller Tray and Nine to 16 FC4600 Drive Trays..... | 741 |
| One CE7922 Controller Tray or CE7900 Controller Tray and 17 to 28 FC4600 Drive Trays..... | 743 |
| One CE7922 Controller Tray or CE7900 Controller Tray and One to Four DE6900 Drive Trays without Trunking..... | 745 |
| One CE7922 Controller Tray or CE7900 Controller Tray Five to Eight DE6900 Drive Trays without Trunking..... | 747 |
| One CE7922 Controller Tray or CE7900 Controller Tray and One to Four DE6900 Drive Trays with Trunking..... | 749 |
| One CE7922 Controller Tray or CE7900 Controller Tray and Five to Eight DE6900 Drive Trays with Drive-Side Trunking..... | 753 |
| One CE7900 Controller Tray and Multiple Types of Drive Trays..... | 757 |
| Drive Cabling Topologies for the CE6998 Controller Tray..... | 758 |
| One CE6998 Controller Tray and One Drive Tray..... | 758 |
| One CE6998 Controller Tray and Two Drive Trays..... | 758 |
| One CE6998 Controller Tray and Four Drive Trays..... | 759 |
| One CE6998 Controller Tray and Eight Drive Trays..... | 761 |
| One CE6998 Controller Tray and Multiple Types of Drive Trays..... | 763 |
| Drive Cabling Topologies for the CE5400 Controller-Drive Trays..... | 765 |
| Drive Cabling Topologies for the CE5400-24 Controller-Drive Tray and the CE5400-12 Controller-Drive Tray..... | 766 |
| Drive Cabling Topologies for the CE5400-60 Controller-Drive Tray..... | 770 |
| Drive Cabling Topologies for the CE4900 Controller-Drive Tray..... | 775 |
| Drive Cabling Topologies for the CDE3994 Controller-Drive Tray and the CDE3992 Controller-Drive Tray..... | 781 |
| One CDE3994 Controller-Drive Tray or CDE3992 Controller-Drive Tray and One Drive Tray..... | 781 |
| One CDE3994 Controller-Drive Tray or CDE3992 Controller-Drive Tray and Two Drive Trays..... | 782 |
| One CDE3994 Controller-Drive Tray or CDE3992 Controller-Drive Tray and Three Drive Trays..... | 782 |
| One CDE3994 Controller-Drive Tray or CDE3992 Controller-Drive Tray and Four Drive Trays..... | 784 |
| One CDE3994 Controller-Drive Tray or CDE3992 Controller-Drive Tray and Five Drive Trays..... | 785 |
| One CDE3994 Controller-Drive Tray or CDE3992 Controller-Drive Tray and Six Drive Trays..... | 787 |
| One CDE3994 Controller-Drive Tray or CDE3992 Controller-Drive Tray and Multiple Types of Drive Trays..... | 789 |
| Drive Cabling Topologies for the CE2600 Controller-Drive Tray..... | 791 |
| Drive Cabling Topologies for the CE2600 Controller-Drive Tray With DE1600 Drive Trays or DE5600 Drive Trays..... | 792 |
| Drive Cabling Topologies for the CE2600-60 Controller-Drive Tray..... | 794 |
| Drive Cabling Topologies for the CE2600-60 Controller-Drive Tray With DE6600 Drive Trays..... | 795 |
| Ethernet Cabling..... | 797 |
| Direct Out-of-Band Ethernet Topology..... | 797 |
| Fabric Out-of-Band Ethernet Topology..... | 798 |
| Component Locations..... | 799 |
| Port Locations on the CE7922 Controller Tray and the CE7900 Controller Tray..... | 799 |

| | |
|---|------------|
| Component Locations on the CE6998 Controller Tray..... | 800 |
| Component Locations on the CE5400 Controller-Drive Trays..... | 801 |
| Component Locations on the CE4900 Controller-Drive Tray..... | 806 |
| Component Locations on the CDE3994 Controller-Drive Tray and the CDE3992 Controller-Drive Tray..... | 807 |
| Component Locations on the CE2600 Controller-Drive Tray..... | 808 |
| Component Locations on the CE2600-60 Controller-Drive Tray..... | 814 |
| Component Locations on the DE6900 Drive Tray..... | 818 |
| Component Locations on the DE6600 Drive Tray..... | 819 |
| Component Locations on the FC4600 Drive Tray..... | 820 |
| Component Locations on the AT2655 Drive Tray..... | 821 |
| Component Locations on the FC2610 Drive Tray..... | 821 |
| Component Locations on the FC2600 Drive Tray..... | 822 |
| Component Locations on the DE1600 Drive Tray and the DE5600 Drive Tray..... | 822 |
| Adding a Drive Tray to an Existing System..... | 824 |
| Getting Ready..... | 824 |
| HotScale Technology..... | 824 |
| Adding Redundant Drive Channels..... | 824 |
| Adding One Non-Redundant Drive Channel..... | 824 |
| Hardware Installation for Remote Volume Mirroring..... | 826 |
| Site Preparation..... | 826 |
| Switch Zoning Overview..... | 826 |
| Hardware Installation..... | 827 |
| Highest Availability Campus Configuration – Recommended..... | 829 |
| Switch Zoning for Highest Availability Campus Configuration..... | 830 |
| Cabling for the Highest Availability Campus Configuration..... | 831 |
| Campus Configuration..... | 834 |
| Switch Zoning for the Campus Configuration..... | 835 |
| Cabling for the Campus Configuration..... | 836 |
| Intra-Site Configuration..... | 839 |
| Switch Zoning for the Intra-Site Configuration..... | 839 |
| Cabling for the Intra-Site Configuration..... | 840 |
| Installing and Using Remote Volume Mirroring with a Wide Area Network..... | 843 |
| Line Capacities..... | 843 |
| Initial Configuration and Software Installation..... | 845 |
| Step 1 – Deciding on the Management Method..... | 846 |
| Key Terms..... | 846 |
| Procedure – Management Method..... | 846 |
| Things to Know – In-Band and Out-of-Band Requirements..... | 848 |
| Step 2 – Setting Up the Storage Array for Windows Server 2008 Server Core..... | 851 |
| Procedure – Configuring the Network Interfaces..... | 851 |
| Procedure – Setting the iSCSI Initiator Services..... | 852 |
| Procedure – Installing the Storage Management Software..... | 852 |
| Procedure – Configuring the iSCSI Ports..... | 853 |
| Procedure – Configuring and Viewing the Targets..... | 853 |
| Procedure – Establishing a Persistent Login to a Target..... | 854 |
| Procedure – Verifying Your iSCSI Configuration..... | 854 |
| Procedure – Reviewing Other Useful iSCSI Commands..... | 855 |
| Procedure – Configuring Your Storage Array..... | 855 |
| Step 3 – Installing the SANtricity ES Storage Manager Software..... | 856 |
| Key Terms..... | 856 |
| Things to Know – All Operating Systems..... | 856 |
| Things to Know – Specific Operating Systems..... | 856 |
| Things to Know – System Requirements..... | 857 |

| | |
|--|-----|
| Procedure – Installing the SANtricity ES Storage Manager Software..... | 859 |
| Things to Know – Software Packages..... | 860 |
| Procedure – Manually Installing RDAC on the Linux OS..... | 863 |
| Step 4 – Configuring the Host Bus Adapters..... | 865 |
| Procedure – Configuring the HBAs..... | 865 |
| Things to Know – Changing to Linux Operating System Settings, Failover Driver Settings, and HBA Settings for DMMP..... | 866 |
| Things to Know – Changing the Linux Failover Driver and HBA Settings for MPP..... | 869 |
| Things to Know – Changing Windows FC and iSCSI HBA Settings..... | 870 |
| Things to Know – Changing the SAS Host Adapters..... | 874 |
| Things to Know – Changing the VMware OS HBA Settings..... | 875 |
| Things to Know – Changing the HP-UX OS for HBAs..... | 876 |
| Step 5 – Starting SANtricity ES Storage Manager..... | 877 |
| For Additional Information..... | 877 |
| Procedure – Starting SANtricity ES Storage Manager..... | 877 |
| Things to Know – Enterprise Management Window and Array Management Window..... | 877 |
| Step 6 – Adding the Storage Array..... | 880 |
| Things to Know – Storage Array..... | 880 |
| Procedure – Automatically Adding a Storage Array..... | 880 |
| Procedure – Manually Adding a Storage Array..... | 880 |
| Things to Know – Rescanning the Host for a New Storage Array..... | 881 |
| Procedure – Rescanning the Host for a New Storage Array..... | 882 |
| Step 7 – Naming the Storage Array..... | 883 |
| Things to Know – Naming the Storage Array..... | 883 |
| Procedure – Naming a Storage Array..... | 883 |
| Step 8 – Resolving Problems..... | 884 |
| Procedure – Resolving Problems..... | 884 |
| Retrieving Trace Buffers..... | 884 |
| Step 9 – Adding Controller Information for the Partially Managed Storage Array..... | 886 |
| Key Terms..... | 886 |
| Things to Know – Partially Managed Storage Arrays..... | 886 |
| Procedure – Automatically Adding a Partially Managed Storage Array..... | 886 |
| Step 10 – Manually Configuring the Controllers..... | 888 |
| Things to Know – Manually Configuring the Controllers..... | 888 |
| Things to Know – Options for Manually Configuring the Controllers..... | 888 |
| Option 1 – Use the In-Band Management Method Initially (Recommended)..... | 889 |
| Option 2 – Set Up a Private Network..... | 889 |
| Procedure – Configuring the Management Station..... | 889 |
| Procedure – Configuring the Controllers..... | 890 |
| Step 11 – Setting a Password..... | 893 |
| Things to Know – Passwords..... | 893 |
| Procedure – Setting a Password..... | 893 |
| Step 12 – Removing a Storage Array..... | 894 |
| Things to Know – Removing Storage Arrays..... | 894 |
| Procedure – Removing a Storage Array..... | 894 |
| Step 13 – Configuring Email Alerts and SNMP Alerts..... | 895 |
| Key Terms..... | 895 |
| Things to Know – Alert Notifications..... | 895 |
| Procedure – Setting Alert Notifications..... | 895 |
| Step 14 – Changing the Cache Memory Settings..... | 897 |
| Key Terms..... | 897 |
| Things to Know – Cache Memory Settings..... | 897 |
| Procedure – Viewing the Cache Memory Size Information..... | 897 |

| | |
|--|------------|
| Procedure – Changing the Cache Memory Settings..... | 897 |
| Procedure – Changing the Volume Cache Memory Settings..... | 898 |
| Step 15 – Enabling the Premium Features..... | 899 |
| Key Terms..... | 899 |
| Things to Know – Premium Features..... | 899 |
| Procedure – Enabling the Premium Features..... | 899 |
| Step 16 – Defining the Hosts..... | 900 |
| Things to Know – Hosts..... | 900 |
| Things to Know – Host Groups..... | 900 |
| Things to Know – Storage Partitions..... | 900 |
| Procedure – Defining the Hosts..... | 903 |
| Procedure – Defining the iSCSI Hosts..... | 903 |
| Step 17 – Configuring the Storage..... | 904 |
| Key Terms..... | 904 |
| Things to Know – Data Assurance..... | 905 |
| Things to Know – Allocating Capacity..... | 905 |
| Things to Know – Volume Groups and Volumes..... | 906 |
| Things to Know – Host-to-Volume Mappings and Storage Partitions..... | 906 |
| Things to Know – Hot Spare Drives..... | 907 |
| Things to Know – Full Disk Encryption..... | 907 |
| Procedure – Configuring the Storage..... | 909 |
| Step 18 – Downloading the Drive and ATA Translator Firmware for SATA Drives and the DE6900 Drive Tray... 911 | |
| Things to Know – A Preview of the Download Drive and ATA Translator Firmware Dialog..... | 912 |
| Procedure – Starting the Download Process..... | 912 |
| Procedure – Selecting the Drive and the ATA Translator Firmware..... | 912 |
| Procedure – Updating the Firmware..... | 913 |
| Procedure – Monitoring the Progress of the Download..... | 913 |
| Remote Volume Mirroring Premium Feature..... | 915 |
| About the Remote Volume Mirroring Premium Feature..... | 916 |
| Primary Volumes and Secondary Volumes..... | 916 |
| Mirror Repository Volumes..... | 916 |
| Using Other Premium Features with Remote Volume Mirroring..... | 917 |
| Using the SANshare Storage Partitioning Premium Feature with Remote Volume Mirroring..... | 917 |
| Using the Snapshot Volume Premium Feature with Remote Volume Mirroring..... | 917 |
| Using the Volume Copy Premium Feature with Remote Volume Mirroring..... | 917 |
| Using the Dynamic Volume Expansion Premium Feature with Remote Volume Mirroring..... | 918 |
| Switching Zoning Configurations for Remote Volume Mirroring..... | 919 |
| Journaling File Systems and Remote Volume Mirroring..... | 920 |
| Prerequisites for Creating a Remote Volume Mirror..... | 921 |
| Obtaining the Remote Volume Mirroring Premium Feature Key..... | 922 |
| Enabling the Remote Volume Mirroring Premium Feature..... | 923 |
| Activating the Remote Volume Mirroring Premium Feature..... | 924 |
| Creating a Volume Group and Mirror Repository Volumes from the Unconfigured Capacity of the Storage Array..... | 924 |
| Creating Mirror Repository Volumes in an Existing Volume Group..... | 925 |
| Creating a Remote Volume Mirror..... | 926 |
| Selecting the Secondary Volume..... | 926 |
| Setting the Write Mode..... | 926 |
| Setting the Synchronization Priority and the Synchronization Method..... | 927 |
| Completing the Remote Volume Mirror..... | 928 |
| Controller Ownership/Preferred Path in a Remote Volume Mirror..... | 929 |

| | |
|--|------------|
| Changing the Controller Ownership/Preferred Path for a Remote Volume Mirror..... | 930 |
| Viewing Information about a Remote Volume Mirror or a Mirror Repository Volume in the Storage Array Profile..... | 931 |
| Viewing Information about a Remote Volume Mirror or a Mirror Repository Volume in the Properties Pane..... | 932 |
| Viewing the Logical Elements of the Secondary Volume in a Remote Volume Mirror..... | 933 |
| Viewing the Physical Components or the Logical Elements of the Primary Volume in a Remote Volume Mirror..... | 934 |
| Changing the Write Mode and the Consistency Group Membership in a Remote Volume Mirror..... | 935 |
| Resynchronizing Volumes in a Remote Volume Mirror..... | 936 |
| Changing the Synchronization Priority and the Synchronization Method of a Remote Volume Mirror..... | 936 |
| Normally Synchronized Volumes in a Remote Volume Mirror..... | 937 |
| Unsynchronized Volumes in a Remote Volume Mirror..... | 938 |
| Automatically Resynchronizing Volumes in a Remote Volume Mirror..... | 938 |
| Manually Resynchronizing Volumes in a Remote Volume Mirror..... | 939 |
| Reversing the Roles of the Primary Volume and the Secondary Volume in a Remote Volume Mirror..... | 940 |
| Promoting the Secondary Volume or Demoting the Primary Volume in a Remote Volume Mirror..... | 941 |
| Suspending a Remote Volume Mirror..... | 942 |
| About Resumed Remote Volume Mirrors..... | 943 |
| Resuming a Remote Volume Mirror..... | 944 |
| Testing Communication Between the Primary Volume and the Secondary Volume in a Remote Volume Mirror..... | 945 |
| Deleting a Volume from a Mirrored Pair in a Storage Array..... | 946 |
| Deleting a Primary Volume in a Mirrored Pair from a Storage Array..... | 946 |
| Deleting a Secondary Volume in a Mirrored Pair from a Storage Array..... | 947 |
| Removing a Remote Volume Mirror from a Storage Array..... | 948 |
| Disabling the Remote Volume Mirroring Premium Feature..... | 949 |
| Deactivating the Remote Volume Mirroring Premium Feature..... | 950 |
| Volume Copy Premium Feature..... | 951 |
| About the Volume Copy Premium Feature..... | 952 |
| Components of the Volume Copy Premium Feature..... | 952 |
| Improve Storage Array Performance..... | 952 |
| Expand Storage Capacity..... | 952 |
| Create Data Backup Volumes..... | 953 |
| Obtaining the Volume Copy Premium Feature Key..... | 954 |
| Enabling the Volume Copy Premium Feature..... | 955 |
| Volume Copy States..... | 956 |
| Input/Output Performance During a Volume Copy Operation..... | 957 |
| System Performance Factors..... | 957 |
| Copy Modification Priority Setting..... | 957 |
| Copy Modification Priority Rate..... | 957 |
| Volume Copy Restrictions..... | 958 |
| Read/Write Restrictions..... | 958 |
| Source Volume Restrictions..... | 958 |
| Target Volume Restrictions..... | 958 |
| Volume Copy and Data Assurance Restrictions..... | 959 |
| Volume Copy and Snapshot Volumes..... | 961 |
| Designating a Source Volume of a Snapshot Volume as the Target Volume of a Volume Copy..... | 961 |
| Restoring Data to a Source Volume from its Associated Snapshot Volume..... | 961 |
| Volume Copy and Journaling File System Formatting..... | 962 |

| | |
|---|------------|
| Creating a Volume Copy..... | 963 |
| Selecting the Source Volume and the Target Volume in a Volume Copy Pair..... | 963 |
| About the Controller Ownership/Preferred Path..... | 963 |
| Changing the Controller Ownership/Preferred Path for a Volume Copy..... | 964 |
| About the Controller Ownership/Preferred Path..... | 965 |
| Monitoring the Progress of a Volume Copy in the Copy Manager..... | 966 |
| Viewing Additional Information about a Volume Copy in the Storage Array Profile..... | 967 |
| Viewing the Physical Components and Logical Elements of a Source Volume in a Volume Copy..... | 968 |
| Viewing the Logical Elements of a Target Volume in a Volume Copy..... | 969 |
| Copy Manager Operations..... | 970 |
| Re-Copying a Volume Copy..... | 971 |
| Stopping an In-Progress Volume Copy..... | 972 |
| Removing a Volume Copy Pair from a Storage Array..... | 973 |
| Changing the Modification Priority of a Volume Copy..... | 974 |
| Changing the Target Volume Permissions for a Volume Copy..... | 975 |
| Obtaining the Volume Copy Premium Feature Key..... | 976 |
| Disabling the Volume Copy Premium Feature..... | 977 |
| Volume Copy Troubleshooting Tips..... | 978 |
| Troubleshooting Modification Operations..... | 978 |
| Troubleshooting Failed Volume Copy Operations..... | 978 |
| Volume Group Relocation..... | 979 |
| Understanding Concepts, Restrictions, and Requirements of Volume Group Relocation..... | 980 |
| Volume Group Relocation..... | 980 |
| Upgrade and Downgrade Restrictions for RAIDCore 1 and RAIDCore 2..... | 980 |
| Software Restrictions and Firmware Restrictions..... | 980 |
| Firmware Requirements for Source Storage Arrays and Destination Storage Arrays..... | 981 |
| Persistent Reservations Are Not Preserved in Volumes or Volume Groups (Storage Management Software Version 8.4x and Later)..... | 981 |
| Support for 256 Volumes Per Partition (Storage Management Software Version 8.4x and Later)..... | 981 |
| General Restrictions of Volume Group Relocation..... | 981 |
| Moving Drive Trays from Multiple Storage Arrays into a Single Storage Array..... | 981 |
| Moving Drives to a Storage Array with No Current Drive Trays..... | 982 |
| Hitachi Drives Installed in a Just a Bunch of Disks (JBOD) Drive Tray Reports Drives as Missing..... | 982 |
| Missing Volumes and Offline Volumes Appear After Volume Group Relocation..... | 982 |
| Excessive Volume Group Relocation..... | 982 |
| Maximum Number of Drives in a Storage Array..... | 983 |
| Volumes Might Become Unstable After Drives Have Been Relocated..... | 983 |
| Solid State Disk (SSD) Drives..... | 983 |
| Drive Firmware Restrictions..... | 983 |
| Premium Feature Restrictions..... | 983 |
| Snapshot Volumes (Storage Management Software Version 8.x and Later)..... | 984 |
| Remote Volume Mirroring (Storage Management Software Version 8.20 and Later)..... | 987 |
| Volume Copy (Storage Management Software Version 8.4x and Later)..... | 987 |
| SafeStore Drive Security..... | 987 |
| Data Assurance..... | 988 |
| Solid State Disk (SSD) Drives..... | 988 |
| Requirements for Moving Configured Hardware..... | 988 |
| Checking the Version of the Enterprise Management Window..... | 988 |
| Checking the Version of the Array Management Window..... | 989 |
| Creating Storage Array All Support Data Collections..... | 989 |
| Checking the Version of the Controller Firmware..... | 990 |

| | |
|--|-------------|
| Checking the Host Types..... | 990 |
| Moving Drives to a New Storage Array for Additional Capacity – Data Is Preserved..... | 991 |
| Relocation Process Overview..... | 991 |
| Relocation Procedure..... | 991 |
| Checking the Status of the Source Storage Array and the Destination Storage Array..... | 991 |
| Deleting the Volume Groups from the Source Storage Array..... | 993 |
| Removing the Drives from the Source Storage Array..... | 994 |
| Installing the Drives in the Destination Storage Array..... | 994 |
| Initializing the Drives in the Destination Storage Array..... | 996 |
| Deleting a Volume Group in the Destination Storage Array..... | 997 |
| Exporting and Importing a Volume Group..... | 998 |
| Exporting a Volume Group..... | 998 |
| Importing a Volume Group..... | 999 |
| Moving a Volume Group to a Different Storage Array – Data Is Preserved..... | 1000 |
| Relocation Process Overview..... | 1000 |
| Locating the Drives in a Volume Group..... | 1000 |
| Checking the Status of the Source Storage Array and the Destination Storage Array..... | 1001 |
| Removing the Copy Pairs..... | 1004 |
| Removing the Mirror Relationships..... | 1004 |
| Deleting a Snapshot Volume..... | 1005 |
| Checking the NVSRAM Bit for the Destination Storage Array..... | 1006 |
| Changing the NVSRAM Bit for the Destination Storage Array..... | 1007 |
| Removing the Drives from the Source Storage Array..... | 1008 |
| Deleting a Missing Volume..... | 1009 |
| Installing the Drives into the Destination Storage Array..... | 1010 |
| Defining New Storage Partitions..... | 1011 |
| Completing the Volume Group Relocation..... | 1012 |
| Moving a Drive Tray to a Different Storage Array – Data Is Preserved..... | 1013 |
| Relocation Process Overview..... | 1013 |
| Locating the Drives in a Volume Group..... | 1013 |
| Checking the Status of the Source Storage Array and the Destination Storage Array..... | 1015 |
| Removing Copy Pairs..... | 1017 |
| Removing the Mirror Relationships..... | 1018 |
| Deleting a Snapshot Volume..... | 1019 |
| Checking the NVSRAM Bit for the Destination Storage Array..... | 1020 |
| Changing the NVSRAM Bit for the Destination Storage Array..... | 1020 |
| Removing and Relocating the Drives..... | 1021 |
| Moving the Drive Trays from the Source Storage Array to the Destination Storage Array..... | 1023 |
| Turning On the Power to the Source Storage Array..... | 1025 |
| Deleting a Missing Volume..... | 1026 |
| Installing the Drive Trays into the Destination Storage Array..... | 1027 |
| Installing the Drives into the Destination Storage Array..... | 1028 |
| Defining New Storage Partitions..... | 1030 |
| Completing the Volume Group Relocation..... | 1030 |
| System Upgrade for Hardware and Software..... | 1032 |
| Preparing to Upgrade Your Storage Management Software..... | 1033 |
| Upgrading the Storage Array to SANtricity ES Storage Manager Version 10.75..... | 1033 |
| Software Packages..... | 1034 |
| Installation Options..... | 1035 |
| Checking the Current Version of the Storage Management Software..... | 1036 |
| Controller Trays and Controller-Drive Trays..... | 1036 |
| Supported Trays and the Maximum Number of Drives and Volumes..... | 1037 |
| Supported Drive Trays..... | 1038 |

| | |
|---|-------------|
| Software Compatibility for Controller-Drive Trays and Controller Trays..... | 1039 |
| HBAs and Driver Information..... | 1043 |
| Driver Information..... | 1043 |
| Upgrading Trays in the Storage Array..... | 1045 |
| Upgrading Options for the Supported Trays..... | 1045 |
| Upgrading the Controller-Drive Trays..... | 1046 |
| Converting a Controller-Drive Tray to a Drive Tray and Adding a Controller Tray..... | 1047 |
| Replacing an Existing Controller Tray with a CE7900 Controller Tray..... | 1048 |
| Upgrading the Firmware and the NVSRAM..... | 1051 |
| Upgrading from Limited High Availability (LHA) to Full High Availability (FHA)..... | 1053 |
| Terms Applicable to LHA and FHA..... | 1053 |
| Upgrading an LHA ESM to an FHA ESM..... | 1054 |
| Required Computing Environment..... | 1057 |
| Supported Operating Systems for SANtricity ES Storage Manager..... | 1057 |
| Supported Operating Systems for the Storage Management Station Only..... | 1057 |
| Failover Protection Using Multi-Path Drivers..... | 1058 |
| Java Runtime Environment..... | 1059 |
| System Requirements for the HP-UX Operating System..... | 1059 |
| System Requirements for the AIX Operating System..... | 1059 |
| System Requirements for the Solaris Operating System..... | 1060 |
| System Requirements for the Linux Operating System..... | 1060 |
| System Requirements for the Windows Operating System..... | 1061 |
| System Requirements for the Windows Server 2003 Operating System..... | 1061 |
| System Requirements for the Windows XP Operating System..... | 1062 |
| System Requirements for the Windows Server 2008 Operating System..... | 1063 |
| System Requirements for the Windows Vista and Windows 7 Operating Systems..... | 1064 |
| System Requirements for the VMware Operating System..... | 1065 |
| Boot Device Installation..... | 1066 |
| Boot Device Support..... | 1066 |
| Installing the Boot Device..... | 1066 |
| Starting the Client Software..... | 1067 |
| Configuring the Boot Volume on the Storage Array..... | 1067 |
| Configuring the Boot Volume on an Unconfigured Capacity Node..... | 1068 |
| Configuring the Boot Volume on a Free Capacity Node..... | 1069 |
| Ensuring a Single Path to the Storage Array..... | 1070 |
| Preparing the Host..... | 1071 |
| Completing the Installation Process..... | 1071 |
| Failover Drivers..... | 1073 |
| Overview of Failover Drivers..... | 1074 |
| Failover Driver Setup Considerations..... | 1074 |
| Supported Failover Drivers Matrix..... | 1075 |
| Failover Configuration Diagrams..... | 1076 |
| Single-Host Configuration..... | 1076 |
| Multi-Host Configuration..... | 1077 |
| Supporting Redundant Controllers..... | 1078 |
| How a Failover Driver Responds to a Data Path Failure..... | 1080 |
| Responding to a Data Path Failure..... | 1081 |
| Responding to a Data Path Failure When You Are a System Administrator..... | 1081 |
| Responding to a Data Path Failure When You Are a Customer and Technical Support Representative..... | 1081 |
| Load-Balancing Policies..... | 1082 |
| Least Queue Depth..... | 1082 |
| Round Robin with Subset I/O..... | 1082 |

| | |
|--|-------------|
| Least Weighted Paths..... | 1082 |
| Configuring Failover Drivers for the Windows OS and the Linux OS..... | 1083 |
| Dividing I/O Activity Between Two RAID Controllers to Obtain the Best Performance..... | 1083 |
| Changing the Preferred Path Online Without Stopping the Applications..... | 1083 |
| Failover Drivers for the Windows Operating System..... | 1084 |
| Microsoft Multipath Input/Output..... | 1084 |
| Windows OS Restrictions..... | 1084 |
| Native SCSI-2 Release/Reservation Commands in a Multipath Environment..... | 1084 |
| Translating SCSI-2 Reservation/Release Commands to SCSI-3 Persistent Reservations..... | 1084 |
| Per-Protocol I/O Timeout Values..... | 1085 |
| Selective LUN Transfer..... | 1085 |
| Windows Failover Cluster..... | 1086 |
| Reduced Failover Timing..... | 1086 |
| Wait Time Settings..... | 1088 |
| Path Congestion Detection and Online/Offline Path States..... | 1089 |
| Configuration Settings for Windows DSM and Linux RDAC..... | 1089 |
| Example Configuration Settings for the Path Congestion Detection Feature..... | 1092 |
| Device Specific Module for the Microsoft MPIO Solution..... | 1093 |
| Device Manager..... | 1103 |
| Failover Drivers for the Linux Operating System..... | 1108 |
| Linux OS Restrictions..... | 1108 |
| Unique Features of RDAC from LSI..... | 1109 |
| Configuration Settings for Windows DSM and Linux RDAC..... | 1109 |
| Prerequisites for Installing RDAC on the Linux OS..... | 1113 |
| Installing SANtricity ES Storage Manager and RDAC on the Linux OS..... | 1114 |
| Installing RDAC Manually on the Linux OS..... | 1114 |
| Making Sure that RDAC Is Installed Correctly on the Linux OS..... | 1115 |
| Configuring Failover Drivers for the Linux OS..... | 1116 |
| Compatibility and Migration..... | 1117 |
| mppUtil Utility..... | 1117 |
| Frequently Asked Questions about Linux Failover Drivers..... | 1120 |
| Device Mapper Features..... | 1122 |
| Device Mapper Features..... | 1122 |
| Known Limitations and Issues of the Device Mapper..... | 1122 |
| Setting Up the multipath.conf File..... | 1123 |
| Installing Device Mapper Multi-Path for the SLES 11.1 OS..... | 1123 |
| Configuring Device Mapper Multi-Path for the SLES 11.1 OS..... | 1123 |
| Verifying that Device Mapper Multi-Path for the SLES 11.1 OS is Installed Correctly..... | 1125 |
| Copy and Rename the Sample File..... | 1125 |
| Determine the Attributes of a Multipath Device..... | 1125 |
| Using the Device Mapper Devices..... | 1127 |
| Troubleshooting the Device Mapper..... | 1128 |
| Failover Drivers for the Solaris Operating System..... | 1129 |
| Solaris OS Restrictions..... | 1129 |
| Prerequisites for Installing MPxIO on the Solaris OS for the First Time..... | 1129 |
| Prerequisites for Installing MPxIO on a Solaris OS that Previously Ran RDAC..... | 1129 |
| Installing MPxIO on the Solaris 9 OS..... | 1130 |
| Enabling MPxIO on the Solaris 10 OS..... | 1131 |
| Configuring Failover Drivers for the Solaris OS..... | 1131 |
| Frequently Asked Questions about Solaris Failover Drivers..... | 1132 |
| Command Line Interface and Script Commands for Version 10.80..... | 1134 |
| Formatting the Commands..... | 1135 |
| Structure of a CLI Command..... | 1135 |

| | |
|--|------|
| Interactive Mode..... | 1135 |
| CLI Command Wrapper Syntax..... | 1136 |
| Command Line Terminals..... | 1137 |
| Structure of a Script Command..... | 1141 |
| Synopsis of the Script Commands..... | 1142 |
| Recurring Syntax Elements..... | 1144 |
| Naming Conventions..... | 1151 |
| Formatting CLI Commands..... | 1152 |
| Formatting Rules for Script Commands..... | 1153 |
| Usage Guidelines..... | 1154 |
| Detailed Error Reporting..... | 1154 |
| Exit Status..... | 1155 |
| Adding Comments to a Script File..... | 1157 |
| Firmware Compatibility Levels..... | 1157 |
| Script Commands..... | 1159 |
| Commands Listed by Function..... | 1159 |
| Controller Commands..... | 1159 |
| Drive Commands..... | 1160 |
| Host Topology Commands..... | 1161 |
| iSCSI Commands..... | 1162 |
| Remote Volume Mirroring Commands..... | 1162 |
| Session Command..... | 1163 |
| Snapshot Commands..... | 1163 |
| Storage Array Commands..... | 1163 |
| Tray Commands..... | 1165 |
| Uncategorized Commands..... | 1166 |
| Volume Commands..... | 1166 |
| Volume Copy Commands..... | 1167 |
| Volume Group Commands..... | 1167 |
| Commands Listed Alphabetically..... | 1168 |
| Activate Host Port..... | 1168 |
| Activate iSCSI Initiator..... | 1168 |
| Activate Remote Volume Mirroring Feature..... | 1168 |
| Activate Storage Array Firmware..... | 1173 |
| Autoconfigure Storage Array..... | 1173 |
| Autoconfigure Storage Array Hot Spares..... | 1177 |
| Check Remote Mirror Status..... | 1178 |
| Check Volume Parity..... | 1178 |
| Clear Drive Channel Statistics..... | 1179 |
| Clear Storage Array Configuration..... | 1180 |
| Clear Storage Array Event Log..... | 1181 |
| Clear Storage Array Firmware Pending Area..... | 1181 |
| Clear Volume Reservations..... | 1181 |
| Clear Volume Unreadable Sectors..... | 1182 |
| Create Host..... | 1183 |
| Create Host Group..... | 1184 |
| Create Host Port..... | 1184 |
| Create iSCSI Initiator..... | 1185 |
| Create RAID Volume (Automatic Drive Select)..... | 1186 |
| Create RAID Volume (Free Extent Based Select)..... | 1191 |
| Create RAID Volume (Manual Drive Select)..... | 1195 |
| Create Remote Mirror..... | 1200 |
| Create Snapshot Volume..... | 1201 |
| Create Storage Array Security Key..... | 1208 |
| Create Volume Copy..... | 1210 |

| | |
|---|------|
| Create Volume Group..... | 1212 |
| Deactivate Remote Mirror..... | 1216 |
| Delete Host..... | 1217 |
| Delete Host Group..... | 1217 |
| Delete Host Port..... | 1218 |
| Delete iSCSI Initiator..... | 1218 |
| Delete Snapshot Volume..... | 1219 |
| Delete Volume..... | 1219 |
| Delete Volume Group..... | 1220 |
| Diagnose Controller..... | 1221 |
| Diagnose Controller iSCSI Host Cable..... | 1222 |
| Diagnose Remote Mirror..... | 1224 |
| Disable External Security Key Management..... | 1224 |
| Disable Storage Array Feature..... | 1225 |
| Disable Storage Array Remote Status Notification..... | 1226 |
| Download Drive Firmware..... | 1226 |
| Download Environmental Card Firmware..... | 1227 |
| Download Power Supply Firmware..... | 1228 |
| Download Storage Array Drive Firmware..... | 1229 |
| Download Storage Array Firmware/NVSRAM..... | 1230 |
| Download Storage Array NVSRAM..... | 1231 |
| Download Tray Configuration Settings..... | 1232 |
| Enable Controller Data Transfer..... | 1232 |
| Enable External Security Key Management..... | 1233 |
| Enable Storage Array Feature..... | 1233 |
| Enable Storage Array Remote Status Notification..... | 1235 |
| Enable Volume Group Security..... | 1235 |
| Export Storage Array Security Key..... | 1236 |
| Import Storage Array Security Key..... | 1237 |
| Load Storage Array DBM Database..... | 1238 |
| Recopy Volume Copy..... | 1238 |
| Recover RAID Volume..... | 1240 |
| Re-create External Security Key..... | 1244 |
| Re-create Remote Volume Mirroring Repository Volume..... | 1244 |
| Re-create Snapshot..... | 1247 |
| Remove Remote Mirror..... | 1249 |
| Remove Volume Copy..... | 1249 |
| Remove Volume LUN Mapping..... | 1250 |
| Repair Volume Parity..... | 1251 |
| Replace Drive..... | 1252 |
| Reset Controller..... | 1253 |
| Reset Storage Array Battery Install Date..... | 1253 |
| Reset Storage Array Diagnostic Data..... | 1254 |
| Reset Storage Array Infiniband Statistics Baseline..... | 1255 |
| Reset Storage Array iSCSI Baseline..... | 1255 |
| Reset Storage Array RLS Baseline..... | 1255 |
| Reset Storage Array SAS PHY Baseline..... | 1256 |
| Reset Storage Array SOC Baseline..... | 1256 |
| Reset Storage Array Volume Distribution..... | 1257 |
| Resume Remote Mirror..... | 1257 |
| Resume Snapshot Rollback..... | 1258 |
| Revive Drive..... | 1258 |
| Revive Volume Group..... | 1259 |
| Save Controller NVSRAM..... | 1260 |
| Save Drive Channel Fault Isolation Diagnostic Status..... | 1260 |

| | |
|--|------|
| Save Drive Log..... | 1261 |
| Save Storage Array Configuration..... | 1261 |
| Save Storage Array DBM Database..... | 1263 |
| Save Storage Array DBM Validator..... | 1263 |
| Save Storage Array Diagnostic Data..... | 1264 |
| Save Storage Array Events..... | 1265 |
| Save Storage Array Firmware Inventory..... | 1266 |
| Save Storage Array InfiniBand Statistics..... | 1267 |
| Save Storage Array iSCSI Statistics..... | 1268 |
| Save Storage Array Performance Statistics..... | 1268 |
| Save Storage Array RLS Counts..... | 1269 |
| Save Storage Array SAS PHY Counts..... | 1269 |
| Save Storage Array SOC Counts..... | 1270 |
| Save Storage Array State Capture..... | 1270 |
| Save Storage Array Support Data..... | 1271 |
| Save Tray Log..... | 1272 |
| Set Controller..... | 1272 |
| Set Controller Service Action Allowed Indicator..... | 1277 |
| Set Drawer Service Action Allowed Indicator..... | 1277 |
| Set Drive Channel Status..... | 1279 |
| Set Drive Hot Spare..... | 1279 |
| Set Drive Service Action Allowed Indicator..... | 1280 |
| Set Drive State..... | 1281 |
| Set Foreign Drive to Native..... | 1282 |
| Set Host..... | 1283 |
| Set Host Channel..... | 1284 |
| Set Host Group..... | 1285 |
| Set Host Port..... | 1285 |
| Set iSCSI Initiator..... | 1286 |
| Set iSCSI Target Properties..... | 1287 |
| Set Remote Mirror..... | 1288 |
| Set Session..... | 1290 |
| Set Snapshot Volume..... | 1291 |
| Set Storage Array..... | 1294 |
| Set Storage Array ICMP Response..... | 1297 |
| Set Storage Array iSNS Server IPv4 Address..... | 1298 |
| Set Storage Array iSNS Server IPv6 Address..... | 1298 |
| Set Storage Array iSNS Server Listening Port..... | 1299 |
| Set Storage Array iSNS Server Refresh..... | 1300 |
| Set Storage Array Learn Cycle..... | 1300 |
| Set Storage Array Redundancy Mode..... | 1301 |
| Set Storage Array Remote Status Notification..... | 1301 |
| Set Storage Array Security Key..... | 1302 |
| Set Storage Array Time..... | 1303 |
| Set Storage Array Tray Positions..... | 1303 |
| Set Storage Array Unnamed Discovery Session..... | 1304 |
| Set Tray Alarm..... | 1304 |
| Set Tray Identification..... | 1305 |
| Set Tray Service Action Allowed Indicator..... | 1306 |
| Set Volume..... | 1307 |
| Set Volume Copy..... | 1315 |
| Set Volume Group..... | 1316 |
| Set Volume Group Forced State..... | 1317 |
| Show Cache Backup Device Diagnostic Status..... | 1318 |
| Show Cache Memory Diagnostic Status..... | 1318 |

| | |
|---|------|
| Show Controller..... | 1319 |
| Show Controller Diagnostic Status..... | 1321 |
| Show Controller NVSRAM..... | 1322 |
| Show Current iSCSI Sessions..... | 1323 |
| Show Drive..... | 1323 |
| Show Drive Channel Statistics..... | 1326 |
| Show Drive Download Progress..... | 1326 |
| Show Host Interface Card Diagnostic Status..... | 1327 |
| Show Host Ports..... | 1328 |
| Show Remote Volume Mirroring Volume Candidates..... | 1328 |
| Show Remote Volume Mirroring Volume Synchronization Progress..... | 1329 |
| Show Storage Array..... | 1329 |
| Show Storage Array Auto Configure..... | 1333 |
| Show Storage Array Host Topology..... | 1336 |
| Show Storage Array LUN Mappings..... | 1337 |
| Show Storage Array Negotiation Defaults..... | 1338 |
| Show Storage Array Remote Status Notification..... | 1339 |
| Show Storage Array Unconfigured iSCSI Initiators..... | 1339 |
| Show Storage Array Unreadable Sectors..... | 1339 |
| Show String..... | 1340 |
| Show Volume..... | 1340 |
| Show Volume Action Progress..... | 1342 |
| Show Volume Copy..... | 1342 |
| Show Volume Copy Source Candidates..... | 1343 |
| Show Volume Copy Target Candidates..... | 1344 |
| Show Volume Group..... | 1344 |
| Show Volume Group Export Dependencies..... | 1345 |
| Show Volume Group Import Dependencies..... | 1345 |
| Show Volume Performance Statistics..... | 1346 |
| Show Volume Reservations..... | 1347 |
| Start Cache Backup Device Diagnostic..... | 1347 |
| Start Cache Memory Diagnostic..... | 1350 |
| Start Configuration Database Diagnostic..... | 1351 |
| Start Controller Diagnostic..... | 1352 |
| Start Controller Trace..... | 1354 |
| Start Drive Channel Fault Isolation Diagnostics..... | 1355 |
| Start Drive Channel Locate..... | 1356 |
| Start Drive Initialize..... | 1357 |
| Start Drive Locate..... | 1358 |
| Start Drive Reconstruction..... | 1358 |
| Start Host Interface Card Diagnostic..... | 1359 |
| Start iSCSI DHCP Refresh..... | 1362 |
| Start Remote Volume Mirroring Synchronization..... | 1362 |
| Start Secure Drive Erase..... | 1363 |
| Start Snapshot Rollback..... | 1363 |
| Start Storage Array iSNS Server Refresh..... | 1364 |
| Start Storage Array Locate..... | 1364 |
| Start Tray Locate..... | 1365 |
| Start Volume Group Defragment..... | 1365 |
| Start Volume Group Export..... | 1365 |
| Start Volume Group Import..... | 1366 |
| Start Volume Group Locate..... | 1367 |
| Start Volume Initialization..... | 1367 |
| Stop Cache Backup Device Diagnostic..... | 1368 |
| Stop Cache Memory Diagnostic..... | 1368 |

| | |
|--|-------------|
| Stop Configuration Database Diagnostic..... | 1369 |
| Stop Controller Diagnostic..... | 1369 |
| Stop Drive Channel Fault Isolation Diagnostics..... | 1370 |
| Stop Drive Channel Locate..... | 1370 |
| Stop Drive Locate..... | 1370 |
| Stop Host Interface Card Diagnostic..... | 1371 |
| Stop Snapshot..... | 1371 |
| Stop Snapshot Rollback..... | 1372 |
| Stop Storage Array Drive Firmware Download..... | 1373 |
| Stop Storage Array iSCSI Session..... | 1373 |
| Stop Storage Array Locate..... | 1373 |
| Stop Tray Locate..... | 1374 |
| Stop Volume Copy..... | 1374 |
| Stop Volume Group Locate..... | 1374 |
| Suspend Remote Mirror..... | 1375 |
| Validate Storage Array Security Key..... | 1376 |
| Deprecated Commands and Parameters..... | 1377 |
| Deprecated Commands..... | 1377 |
| Deprecated Parameters..... | 1377 |
| Configuring and Maintaining a Storage Array Using the Command Line Interface..... | 1379 |
| About the Command Line Interface..... | 1380 |
| Structure of a CLI Command..... | 1380 |
| Interactive Mode..... | 1381 |
| CLI Command Wrapper Syntax..... | 1381 |
| Command Line Terminals..... | 1383 |
| Formatting CLI Commands..... | 1386 |
| Usage Examples..... | 1387 |
| Exit Status..... | 1388 |
| About the Script Commands..... | 1391 |
| Structure of a Script Command..... | 1391 |
| Synopsis of the Script Commands..... | 1393 |
| Recurring Syntax Elements..... | 1395 |
| Usage Guidelines..... | 1402 |
| Adding Comments to a Script File..... | 1402 |
| Configuring a Storage Array..... | 1403 |
| Configuration Concepts..... | 1404 |
| Controllers..... | 1404 |
| Drives..... | 1406 |
| Hot Spare Drives..... | 1408 |
| SafeStore Drive Security with Full Disk Encryption..... | 1409 |
| Volume Groups..... | 1410 |
| Volumes..... | 1411 |
| RAID Levels..... | 1413 |
| Hosts..... | 1414 |
| Host Groups..... | 1414 |
| Host Bus Adapter Host Ports..... | 1415 |
| Logical Unit Numbers..... | 1415 |
| Configuring a Storage Array..... | 1415 |
| Determining What Is on Your Storage Array..... | 1416 |
| Clearing the Configuration..... | 1418 |
| Using the Auto Configure Command..... | 1419 |
| Using the Create Volume Command..... | 1421 |
| Modifying Your Configuration..... | 1424 |
| Setting the Controller Clocks..... | 1424 |

| | |
|--|------|
| Setting the Storage Array Password..... | 1424 |
| Setting the Storage Array Host Type..... | 1425 |
| Setting the Storage Array Cache..... | 1426 |
| Setting the Modification Priority..... | 1429 |
| Assigning Global Hot Spares..... | 1430 |
| Saving a Configuration to a File..... | 1430 |
| Using the Snapshot Premium Feature..... | 1431 |
| How Snapshot Works..... | 1431 |
| Creating a Snapshot Volume..... | 1432 |
| Creating a Snapshot Volume with User-Assigned Drives..... | 1433 |
| Creating a Snapshot Volume with Software-Assigned Drives..... | 1434 |
| Creating a Snapshot Volume by Specifying a Number of Drives..... | 1434 |
| User-Defined Parameters..... | 1435 |
| Snapshot Volume Names and Snapshot Repository Volume Names..... | 1437 |
| Changing Snapshot Volume Settings..... | 1437 |
| Stopping, Restarting, and Deleting a Snapshot Volume..... | 1438 |
| Using the Remote Volume Mirroring Premium Feature..... | 1440 |
| How Remote Volume Mirroring Works..... | 1440 |
| Mirror Repository Volumes..... | 1441 |
| Mirror Relationships..... | 1441 |
| Data Replication..... | 1441 |
| Link Interruptions or Secondary Volume Errors..... | 1442 |
| Resynchronization..... | 1443 |
| Performance Considerations..... | 1443 |
| Enabling the Remote Volume Mirroring Premium Feature..... | 1444 |
| Activating the Remote Volume Mirroring Premium Feature..... | 1444 |
| Determining Candidates for a Remote Mirrored Pair..... | 1446 |
| Creating a Remote Mirrored Pair..... | 1447 |
| Changing Remote Volume Mirroring Settings..... | 1448 |
| Suspending and Resuming a Mirror Relationship..... | 1448 |
| Removing a Mirror Relationship..... | 1449 |
| Deleting a Primary Volume or a Secondary Volume..... | 1450 |
| Disabling the Remote Volume Mirroring Premium Feature..... | 1450 |
| Deactivating the Remote Volume Mirroring Premium Feature..... | 1450 |
| Interaction with Other Premium Features..... | 1450 |
| Storage Partitioning..... | 1450 |
| Snapshot Volumes..... | 1451 |
| Volume Copy..... | 1451 |
| Dynamic Volume Expansion..... | 1451 |
| Using the Volume Copy Premium Feature..... | 1453 |
| How Volume Copy Works..... | 1453 |
| Source Volume..... | 1453 |
| Target Volume..... | 1454 |
| Volume Copy and Persistent Reservations..... | 1454 |
| Storage Array Performance..... | 1455 |
| Restrictions..... | 1455 |
| Volume Copy Commands..... | 1455 |
| Creating a Volume Copy..... | 1456 |
| Enabling the Volume Copy Premium Feature..... | 1457 |
| Determining Volume Copy Candidates..... | 1457 |
| Creating a Volume Copy..... | 1457 |
| Viewing Volume Copy Properties..... | 1458 |
| Changing Volume Copy Settings..... | 1459 |
| Recopying a Volume..... | 1460 |
| Stopping a Volume Copy..... | 1461 |

| | |
|--|------|
| Removing Copy Pairs..... | 1461 |
| Interaction with Other Premium Features..... | 1461 |
| Storage Partitioning..... | 1462 |
| Snapshot Volumes..... | 1462 |
| Remote Volume Mirroring..... | 1463 |
| Maintaining a Storage Array..... | 1465 |
| Routine Maintenance..... | 1465 |
| Running a Media Scan..... | 1465 |
| Running a Redundancy Check..... | 1466 |
| Resetting a Controller..... | 1466 |
| Enabling a Controller Data Transfer..... | 1467 |
| Resetting the Battery Age..... | 1467 |
| Removing Persistent Reservations..... | 1467 |
| Synchronizing the Controller Clocks..... | 1467 |
| Locating Drives..... | 1467 |
| Relocating a Volume Group..... | 1468 |
| Performance Tuning..... | 1469 |
| Monitoring the Performance..... | 1469 |
| Changing the RAID Levels..... | 1470 |
| Changing the Segment Size..... | 1470 |
| Changing the Cache Parameters..... | 1471 |
| Defragmenting a Volume Group..... | 1471 |
| Troubleshooting and Diagnostics..... | 1472 |
| Detailed Error Reporting..... | 1472 |
| Collecting All Support Data..... | 1472 |
| Collecting Drive Data..... | 1474 |
| Diagnosing a Controller..... | 1474 |
| Running Read Link Status Diagnostics..... | 1475 |
| Collecting Switch-on-a-Chip Error Statistics..... | 1478 |
| Recovery Operations..... | 1479 |
| Setting the Controller Operational Mode..... | 1479 |
| Changing the Controller Ownership..... | 1480 |
| Initializing a Drive..... | 1480 |
| Reconstructing a Drive..... | 1480 |
| Initializing a Volume..... | 1480 |
| Redistributing Volumes..... | 1481 |
| Replacing Canisters..... | 1481 |
| Examples of Information Returned by the Show Commands..... | 1484 |
| Show Storage Array..... | 1484 |
| Show Controller NVSRAM..... | 1498 |
| Show Volume..... | 1501 |
| Show Drive Channel Stat..... | 1507 |
| Show Drive..... | 1512 |
| Example Script Files..... | 1519 |
| Configuration Script Example 1..... | 1519 |
| Configuration Script Example 2..... | 1521 |
| Asynchronous Remote Volume Mirroring Utility..... | 1522 |
| Description of the Asynchronous Remote Volume Mirroring Utility..... | 1522 |
| Operation of the Asynchronous Remote Volume Mirroring Utility..... | 1522 |
| Running the Asynchronous Remote Volume Mirroring Utility..... | 1523 |
| Configuration Utility..... | 1523 |
| Simplex-to-Duplex Conversion..... | 1526 |
| General Steps..... | 1526 |
| Tools and Equipment..... | 1526 |

| | |
|---|------|
| Step 1 – Installing the Duplex NVSRAM..... | 1526 |
| Downloading the NVSRAM by Using the Command Line Interface..... | 1527 |
| Downloading the NVSRAM by Using the GUI..... | 1527 |
| Copying NVSRAM from the Installation CD..... | 1527 |
| Step 2 – Setting the Configuration to Duplex..... | 1528 |
| Step 3 – Installing the Second Controller..... | 1528 |
| Step 4 – Connecting the Host Cables..... | 1528 |
| Step 5 – Connecting the Controller to a Drive Tray..... | 1529 |
| Step 6 – Running Diagnostics..... | 1530 |

Electronic Document for SANtricity 10.80

This electronic document provides the basic information about the features and functions of the SANtricity ES Storage Manager for Version 10.80.

Controller-drive trays have revised naming conventions, changing "CDE" to "CE" before the number, so that the CDE2600 controller-drive tray becomes the CE2600 controller-drive tray. Because some information units are not being updated for the current release, the following documents contain technically accurate information, but still use the older product names:

- *CDE4900 Controller-Drive Tray Installation*
- *CDE2600 Controller-Drive Tray Installation*
- *CDE2600-60 Controller-Drive Tray Installation*

SANtricity ES Concepts for Version 10.80

These topics provide the conceptual framework necessary to understand the features and functions of the SANtricity ES Storage Manager for Version 10.80.

Storing Your Data

The topics in this section describe the basic storage concepts, methods for managing storage arrays, including data-protection strategies, and multi-path failover drivers.

For additional information and detailed procedures for the options described in this section, refer to the online help topics for your version of the storage management software.

Storage Arrays

A storage array has redundant components, including drives, controllers, power supplies, and fans. These redundant components keep the storage array operational if a single component fails.

The storage array configuration provides a secure and robust system with which to store large amounts of data and allows for a variety of backup and retrieval scenarios. Administrators can set up the storage management software to maintain a specific level of security and configuration on the storage area network, such that the network requires little human interaction to perform its daily functions.

Storage Area Networks

A storage area network (SAN) transfers data between computers and storage systems. A SAN is comprised of many hardware components. Each hardware component might have a device manager or third-party management software.

A SAN includes one or more storage arrays that are managed by one or more servers or hosts running the SANtricity ES Storage Manager.



NOTE The SANtricity ES Storage Manager software is also referred to as the storage management software.

You can use the storage management software to add, monitor, manage, and remove the storage arrays on your SAN.

Within the storage management software, you can configure the data to be stored in a particular configuration over a series of physical storage components and logical (virtual) storage components.

The I/O data and management instructions are sent from a host to the controllers in the storage array. When the I/O data reaches the controllers, they are distributed across a series of drives, which are mounted in trays.

The SAN can also include storage management stations, which also run the storage management software. A storage management station manages the storage arrays but does not send I/O data to them. Although physical storage array configurations vary, all SANs work using these basic principles.

Management Methods

Depending on your system configuration, you can use an out-of-band management method, an in-band management method, or both to manage a storage array controller from a storage management station or host.



IMPORTANT A maximum of eight storage management stations can concurrently monitor an out-of-band managed storage array. This limit does not apply to systems that manage the storage array through the in-band management method.

Out-of-Band Management

You can use the out-of-band management method to manage a storage array directly over the network through an Ethernet connection, from a storage management station to the ethernet port on the controllers. This management method lets you manage all of the functions in the storage array.



IMPORTANT Storage management stations require Transmission Control Protocol/Internet Protocol (TCP/IP) to support the out-of-band management of storage arrays.

In-Band Management

You can use the in-band management method to manage a storage array in which the controllers are managed through an I/O connection from a storage management station to a host that is running host-agent software. The I/O connection can be Serial Attached SCSI (SAS), Fibre Channel (FC), or internet SCSI (iSCSI). The host-agent software receives communication from the storage management client software and passes it to the storage array controllers along an I/O connection. The controllers also use the I/O connections to send event information back to the storage management station through the host.

When you add storage arrays by using this management method, you must specify only the host name or IP address of the host. After you add the specific host name or IP address, the host-agent software automatically detects any storage arrays that are connected to that host.



NOTE Systems running desktop (non-server) Windows operating systems and desktop Linux operating systems can be used only as storage management stations. You cannot use systems running desktop operating systems to perform I/O to the storage array and to run the host-agent software.

RAID Levels and Data Redundancy

RAID is an acronym for Redundant Array of Independent Disks. The storage solution stores the same data or information about the data (parity) in different places on multiple hard drives. Data can be written in parallel to multiple drives, which can improve performance. If a drive fails, the redundant data or parity data is used to regenerate the data on the replacement drive.

RAID relies on a series of configurations, called levels, to determine how user data and redundancy data are written to and retrieved from the drives. Each level provides different performance features and protection features. The storage management software offers six formal RAID level configurations: RAID Level 0, RAID Level 1, RAID Level 3, RAID Level 5, RAID Level 6, and RAID Level 10.

RAID Level 1, RAID Level 3, RAID Level 5, RAID Level 6, and RAID Level 10 write redundancy data to the drive media for fault tolerance. The redundancy data might be a copy of the data or parity data. Parity data is derived through a logical operation on the data, and is used for reconstruction of lost data. The parity data might exist on only one drive, or the parity data might be distributed among all of the drives in a volume group.

The controller logically groups a set of drives together to create a volume group. Each volume group can contain one or more volumes. You can configure only *one* RAID level across each volume group. Each volume group stores its own redundancy data. The capacity of the volume group is the aggregate capacity of the member drives, minus the capacity that is reserved for redundancy data. The amount of capacity needed for redundancy data depends on the RAID level used.

Dynamic RAID-Level Migration

Dynamic RAID-Level Migration (DRM) is a modification operation that lets you change the RAID level on a selected volume group without impacting the I/O. You can continue to access data on volume groups, volumes, and drives during the migration process.

The volume group must contain sufficient free space and the required number of drives, or the DRM request is rejected. You cannot cancel the DRM operation after the process begins.



NOTE If RAID Level 6 is a premium feature on your storage array, you must enable RAID Level 6 with a feature key file before migrating a volume group to RAID Level 6.

RAID Level Configuration Table

| RAID Level | Short Description | Detailed Description |
|-------------------------------|--|---|
| RAID Level 0 | No protection against loss of a drive (non-redundant), striping mode | <ul style="list-style-type: none"> ▪ A minimum of one drive is required for RAID Level 0. ▪ RAID Level 0 can use the maximum number of drives in a storage array. ▪ You can use RAID Level 0 for high-performance needs, but it does not provide <i>data redundancy</i>. ▪ Data is striped across all of the drives in the volume group. ▪ Do not use this RAID level for high data-availability needs. RAID Level 0 is better for non-critical data. ▪ A single drive failure in a volume group causes all of the volumes associated with the volume group to fail, and data loss will occur |
| RAID Level 1 or RAID Level 10 | Striping and mirroring mode | <ul style="list-style-type: none"> ▪ A minimum of two drives are required for RAID Level 1: one for the user data and one for the mirrored data. If you select four or more drives, RAID Level 10 is automatically configured across the volume group: two drives for the user data, and two drives for the mirrored data. ▪ RAID Level 1 and RAID Level 10 can use the maximum number of drives in a storage array. ▪ RAID Level 1 and RAID Level 10 typically provide the best write performance, but not in all cases. On a RAID Level 1 volume, data is written to a duplicate drive. On a RAID Level 10 volume, data is striped across mirrored pairs. ▪ If one of the drives in a drive-pair fails, the system can instantly switch to the other drive without any loss of data or service. ▪ RAID Level 1 and RAID Level 10 use drive mirroring to make an exact copy from one drive to another. ▪ A single drive failure causes associated volumes to become degraded, but the mirror drive allows access to the data. ▪ Two or more drive failures in a volume group causes the volumes associated with the volume group to fail, and data loss will occur. |

| RAID Level | Short Description | Detailed Description |
|--------------|--|---|
| RAID Level 3 | High-bandwidth mode | <ul style="list-style-type: none"> ▪ A minimum of three drives is required for RAID Level 3. ▪ RAID Level 3 is limited to a maximum of 30 drives in a volume group. ▪ RAID Level 3 stripes both user data and redundancy data (parity) across the drives. ▪ RAID Level 3 uses the equivalent of the capacity of one drive (in a volume group) for redundancy data. ▪ RAID Level 3 is used for applications with large data transfers, such as multimedia or medical imaging that write and read large sequential chunks of data. ▪ A single drive failure in a volume group causes the associated volumes to become degraded, but the redundancy data allows access to the data. ▪ Two or more drive failures in a volume group causes the volumes associated with the volume group to fail, and data loss will occur. |
| RAID Level 5 | High I/O mode | <ul style="list-style-type: none"> ▪ A minimum of three drives is required for RAID Level 5. ▪ RAID Level 5 is limited to a maximum of 30 drives in a volume group. ▪ RAID Level 5 stripes both user data and redundancy data (parity) across the drives. ▪ RAID Level 5 uses the equivalent of the capacity of one drive (in a volume group) for redundancy data. ▪ A single drive failure in a volume group causes associated volumes to become degraded, but the redundancy data allows access to the data. ▪ Two or more drive failures in a volume group causes the volumes associated with the volume group to fail, and data loss will occur. |
| RAID Level 6 | High I/O mode with simultaneous drive failure protection | <ul style="list-style-type: none"> ▪ A minimum of five drives is required for RAID Level 6. ▪ RAID Level 6 is limited to a maximum of 30 drives in a volume group. ▪ RAID Level 6 stripes both user data and redundancy data (parity) across the drives. ▪ RAID Level 6 uses the equivalent of the capacity of two drives (in a volume group) for redundancy data. ▪ RAID Level 6 provides the best data availability. RAID Level 6 protects against the simultaneous failure of two volume group member drives by using two independent error-correction schemes. |

Hardware Redundancy

Data-protection strategies provided by the storage array hardware include controller cache memory, hot spare drives, background media scans, and channel protection.

Controller Cache Memory

Write caching, or caching a drive segment to a memory buffer before writing to the drive, can increase I/O performance during data transfers.

Write-cache mirroring protects data during a controller-memory failure or a cache-memory failure. When you enable write cache, cached data is mirrored across two redundant controllers with the same cache size. Therefore, if one controller fails, the alternate controller can complete all outstanding write operations.

To prevent data loss or corruption, the controller periodically writes cache data to a drive (flushes the cache) when the amount of unwritten data in the cache reaches a certain level, called a start percentage, or when data has been in the cache for a predetermined amount of time. The controller continues to write data to a drive until the amount of data in the cache drops to a stop percentage level. You can configure the start percentage and the stop percentage to suit your own storage requirements. For example, you can specify that the controller start flushing the cache when it reaches 80-percent full and stop flushing the cache when it reaches 16-percent full.

In case of power outages, data in the controller cache memory is protected. Controller trays and controller-drive trays contain batteries that protect the data in the cache by maintaining a level of power until the data can be written to the drive media or a flash memory card.

If the controller supports a flash memory card, the cache data can be written to the flash memory card when a power outage occurs. For example, the CE2600 controller-drive tray supports a flash memory card to write the cache data. The battery is only needed to maintain power while the data in the cache is written to the flash memory card. The flash memory card provides nonvolatile backup of the cache data in case of long power outages. When power is restored to the controllers, the cache data can be read from the flash memory card.

If a power outage occurs when there is no UPS, and there is no battery or the battery is damaged, the data in the cache that has not been written to the drive media is lost. This situation occurs even if the data is mirrored to the cache memory of both controllers. It is, therefore, important to change the batteries in the controller tray and the controller-drive tray at the recommended time intervals.

Tray Loss Protection

When you create a volume group using the tray loss protection feature, all of the drives in the volume group are found in different drive trays. Tray loss protection provides more data protection if access to the tray is lost. This feature is used by default when you choose the automatic configuration option.

Tray loss protection depends on the number of trays that are available, the value set for the Redundant Array of Independent Disks (RAID) level, and the number of drives in the volume group. For example, tray loss protection cannot be achieved if a RAID Level 5 volume group is comprised of eight drives, but there are only three trays. Configuring your volume groups to have tray loss protection is recommended. If your configuration supports the minimum number of drive trays for your RAID level, create your volume groups to have tray loss protection.

| RAID Level | Criteria for Tray Loss Protection |
|-------------------------------|---|
| RAID Level 0 | No tray loss protection (RAID Level 0 does <i>not</i> provide redundancy). |
| RAID Level 1 or RAID Level 10 | For RAID Level 1, the volume group must use a minimum of two drives found in separate trays. For RAID Level 10, the volume group must use a minimum of four drives found in separate trays. |
| RAID Level 3 | The volume group must use a minimum of three drives found in separate trays. |

| RAID Level | Criteria for Tray Loss Protection |
|--------------|---|
| RAID Level 5 | The volume group must use a minimum of three drives found in separate trays. |
| RAID Level 6 | The volume group must use a minimum of five drives, with a maximum of two drives in any tray. |

Drawer Loss Protection

Drawer loss protection is a characteristic of a volume group and is available only in the DE6900 drive tray and the DE6600 drive tray.

In drive trays that contain drives in drawers, a drawer failure can lead to inaccessibility of data on the volumes in a volume group. A drawer might fail because of a loss of power, a failure of an environmental services monitor (ESM), or a failure of an internal component within the drawer.

The availability of drawer loss protection for a volume group is based on the location of the drives that comprise the volume group. In the event of a single drawer failure, data on the volumes in a volume group remains accessible if the volume group has drawer loss protection. If a drawer fails and the volume group is drawer loss protected, the volume group changes to Degraded status, and the data remains accessible.

To achieve drawer loss protection, make sure that the drives that comprise a volume group are located in different drawers with respect to their RAID levels as shown in this table.

| RAID Level | Criteria for Drawer Loss Protection |
|--------------------------------|--|
| RAID Level 3 and RAID Level 5 | RAID Level 3 and RAID Level 5 require a minimum of three drives. Place all of the drives in different drawers for a RAID Level 3 volume group and for a RAID Level 5 volume group to achieve drawer loss protection. Drawer loss protection cannot be achieved for RAID Level 3 and RAID Level 5 if more than one drive is placed in the same drawer. |
| RAID Level 6 | RAID Level 6 requires a minimum of five drives. Place all of the drives in different drawers or place a maximum of two drives in the same drawer and the remaining drives in different drawers to achieve drawer loss protection for a RAID Level 6 volume group. |
| RAID Level 1 and RAID Level 10 | RAID Level 1 requires a minimum of two drives. Make sure that each drive in a mirrored pair is located in a different drawer. If you make sure that each drive in a mirrored pair is located in a different drawer, you can have more than two drives of the volume group within the same drawer. For example, if you create a RAID Level 1 volume group with six drives (three mirrored pairs), you can achieve the drawer loss protection for the volume group with only two drawers as shown in this example: Six-drive RAID Level 1 volume group: <ul style="list-style-type: none"> ▪ Mirror pair 1 = Drive in tray 1, drawer 1, slot 1, and drive in tray 1, drawer 2, slot 1 ▪ Mirror pair 2 = Drive in tray 1, drawer 1, slot 2, and drive in tray 1, drawer 2, slot 2 ▪ Mirror pair 3 = Drive in tray 1, drawer 1, slot 3, and drive in tray 2, drawer 2, slot 3 |

| RAID Level | Criteria for Drawer Loss Protection |
|--------------|---|
| | RAID Level 10 requires a minimum of four drives. Make sure that each drive in a mirrored pair is located in a different drawer. |
| RAID Level 0 | You cannot achieve drawer loss protection because the RAID Level 0 volume group does not have redundancy. |

 **NOTE** If you create a volume group by using the automatic drive selection method, the storage management software attempts to choose drives that provide drawer loss protection. If you create a volume group by using the manual drive selection method, you must use the criteria that are specified in the previous table. For more information about how to create volume groups, refer to the Using the Create Volume Group Wizard online help topic in the Array Management Window of SANtricity ES Storage Manager.

If a volume group already has a Degraded status due to a failed drive when a drawer fails, drawer loss protection does not protect the volume group. The data on the volumes becomes inaccessible.

Hot Spare Drives

A valuable strategy to protect data is to assign available drives in the storage array as hot spare drives. A hot spare is a drive, containing no data, that acts as a standby in the storage array in case a drive fails in a RAID Level 1, RAID Level 3, RAID Level 5, RAID Level 6, or RAID Level 10 volume group. The hot spare adds another level of redundancy to the storage array. Generally, hot spare drives must have capacities that are equal to or greater than the used capacity on the drives that they are protecting. Hot spare drives must be of the same media type and the same interface type as the drives that they are protecting.

If a drive fails in the storage array, the hot spare can be substituted automatically for the failed drive without requiring your intervention. If a hot spare is available when a drive fails, the controller uses redundancy data to reconstruct the data onto the hot spare. After the failed drive is physically replaced, you can use either of the following options to restore the data:

- When you have replaced the failed drive, the data from the hot spare is copied back to the replacement drive. This action is called *copyback*.
- You can assign the hot spare as a permanent member of the volume group. Performing the copyback function is not required for this option.

The availability of tray loss protection and drawer loss protection for a volume group depends on the location of the drives that comprise the volume group. Tray loss protection and drawer loss protection might be lost because of a failed drive and the location of the hot spare drive. To make sure that tray loss protection and drawer loss protection are not affected, you must replace a failed drive to initiate the copyback process.

The storage array automatically selects Data Assurance (DA) -capable drives for hot spare coverage of DA-enabled volumes. Make sure to have DA-capable drives in the storage array for hot spare coverage of DA-enabled volumes.

Security capable drives provide coverage for both security capable and non-security capable drives. Non-security capable drives can provide coverage only for other non-security capable drives.

If you do not have a hot spare, you can still replace a failed drive while the storage array is operating. If the drive is part of a RAID Level 1, RAID Level 3, RAID Level 5, RAID Level 6, or RAID Level 10 volume group, the controller uses redundancy data to automatically reconstruct the data onto the replacement drive. This action is called *reconstruction*.

Channel Protection

In a Fibre Channel environment, channel protection is usually present for any storage array. When the storage array is cabled correctly, two redundant arbitrated loops (ALs) exist for each drive.

I/O Data Path Protection

Input/output (I/O) data path protection to a redundant controller in a storage array is accomplished with these multi-path drivers:

- The Auto-Volume Transfer (AVT) feature and the Multi-Path I/O (MPIO) driver in the Windows operating system (OS)
- The Multi-Path Proxy (MPP) -based Redundant Dual Active Controller (RDAC) multi-path driver and the Device Mapper Multi-Path (DMMP) driver in the Linux OS
- The Multi-Plexed I/O (MPxIO) driver in the Solaris OS
- The native failover driver using Target Port Group Support (TPGS) in the HP-UX OS version 11.31
- The native failover driver in the VMware OS
- The native failover driver using TPGS in the Mac OS X

AVT is a built-in feature of the controller firmware that permits ownership of a volume to be transferred to a second controller if the preferred controller fails. When you use AVT with a multi-path driver, AVT helps to make sure that an I/O data path is always available for the volumes in the storage array.

If a component, such as a controller, a cable, or an environmental services monitor (ESM), fails, or an error occurs on the data path to the preferred controller, AVT and the multi-path driver automatically transfer the volume groups and volumes to the alternate “non-preferred” controller for processing. This failure or error is called a failover.

Multi-path drivers, such as MPIO, RDAC, and MPxIO, are installed on host computers that access the storage array and provide I/O path failover. The AVT feature is used specifically for single-port cluster failover. The AVT feature mode is automatically selected by the host type.

Multi-Path Driver with AVT Enabled

Enabling AVT in your storage array and using it with a host multi-path driver helps to make sure that an I/O data path is always available for the storage array volumes.

When you create a volume in a storage array where AVT is enabled, a controller must be assigned to own the volume, called the preferred owner. The preferred controller normally receives the I/O requests to the volume. If a problem along the data path, such as a component failure, causes an I/O request to fail, the multi-path driver sends the I/O to the alternate controller.



IMPORTANT You should have the multi-path driver installed at all times. You should always enable the AVT mode. Set the AVT mode to a single port cluster host type.

After the I/O data path problem is corrected, the preferred controller automatically re-establishes ownership of the volume as soon as the multi-path driver detects that the path is normal again.

Multi-Path Driver with AVT Disabled

When you disable AVT in your storage array, the I/O data path is still protected as long as a multi-path driver is installed on each host that is connected to the storage array. However, when an I/O request is sent to a specified volume, and a problem occurs along the data path to its preferred controller, all volumes on the preferred controller are transferred to the alternate controller, not just the specified volume.

Target Port Group Support

Target Port Group Support (TPGS) is another multi-path driver that is available on specific combinations of operating systems and failover drivers that can be present on a host. TPGS provides failover for a storage array. Failover is an automatic operation that switches the data path for a volume from the preferred controller to the alternate controller in the case of a hardware failure.

TPGS is part of the ANSI T10 SPC-3 specification. It is implemented in the controller firmware. TPGS is similar to other multi-pathing options, such as Auto-Volume Transfer (AVT) and Redundant Dual Active Controller (RDAC), which were developed prior to defining a multi-pathing standard. The advantage of TPGS is that it is based on the current standard, which allows interoperability with multi-pathing solutions from other vendors. Interoperability with other multi-pathing solutions simplifies administration of the host.

Each host type uses only one of the multi-path methods: RDAC, AVT, or TPGS.

Load Balancing

Load balancing is the redistribution of read/write requests to maximize throughput between the server and the storage array. Load balancing is very important in high workload settings or other settings where consistent service levels are critical. The multi-path driver transparently balances I/O workload without administrator intervention. Without multi-path software, a server sending I/O requests down several paths might operate with very heavy workloads on some paths, while other paths are not used efficiently.

The multi-path driver determines which paths to a device are in an active state and can be used for load balancing. The load-balancing policy uses one of three algorithms: round robin, least queue depth, or least path weight. Multiple options for setting the load-balancing policies let you optimize I/O performance when mixed host interfaces are configured. The load-balancing policies that you can choose depend on your operating system. Load balancing is performed on multiple paths to the same controller, but not across both controllers.

| Operating System | Multi-Path Driver | Load Balancing Policy |
|---------------------------------|-------------------|---|
| Windows | MPIO DSM | Round robin, least queue depth, least path weight |
| Red Hat Enterprise Linux (RHEL) | RDAC | Round robin, least queue depth |
| SUSE Linux Enterprise (SLES) | RDAC | Round robin, least queue depth |
| Solaris | MPxIO | Round robin |

Round Robin with Subset

The round-robin with subset I/O load-balancing policy routes I/O requests, in rotation, to each available data path to the controller that owns the volumes. This policy treats all paths to the controller that owns the volume equally for I/O activity. Paths to the secondary controller are ignored until ownership changes. The basic assumption for the round-robin policy is that the data paths are equal. With mixed-host support, the data paths might have different bandwidths or different data transfer speeds.

Least Queue Depth with Subset

The least queue depth with subset policy is also known as the least I/Os policy or the least requests policy. This policy routes the next I/O request to the data path on the controller that owns the volume that has the least outstanding I/O requests queued. For this policy, an I/O request is a command in the queue. The type of command or the number of blocks that are associated with the command is not considered. The least queue depth with subset policy treats large block requests and small block requests equally. The data path selected is one of the paths in the path group of the controller that owns the volume.

Least Path Weight with Subset

The least path weight with subset policy assigns a weight factor to each data path to a volume. An I/O request is routed to the path with the lowest weight value to the controller that owns the volume. If more than one data path to the volume has the same weight value, the round-robin with subset path selection policy is used to route I/O requests between the paths with the same weight value.

Introducing the Storage Management Software

The topics in this section describe the basic layout of the SANtricity ES Storage Manager software. The SANtricity ES Storage Manager software has two windows that provide management functionality and a graphical representation of your storage array: the Enterprise Management Window (EMW) and the Array Management Window (AMW).



NOTE The SANtricity ES Storage Manager software is also referred to as the storage management software.

In general, you will use the following process when using the storage management software. You use the EMW to add the storage arrays that you want to manage and monitor. Through the EMW, you also receive alert notifications of errors that affect the storage arrays. If you are notified in the EMW that a storage array has a non-Optimal status, you can start the AMW for the affected storage array to show detailed information about the storage array condition.



IMPORTANT Depending on your version of storage management software, the views, menu options, and functionality might differ from the information presented in this section. For information about available functionality, refer to the online help topics that are supplied with your version of the storage management software.

Enterprise Management Window

The Enterprise Management Window (EMW) is the first window to appear when you start the storage management software. The EMW lets you perform these management tasks:

- Discover hosts and storage arrays automatically on your local sub-network.
- Manually add and remove hosts and storage arrays.
- Monitor the health of the storage arrays and report a high-level status by using the applicable icon.
- Configure alert notifications through email or Simple Network Management Protocol (SNMP) and report events to the configured alert destinations.
- Launch the applicable Array Management Window (AMW) for a selected storage array to perform detailed configuration and management operations.
- Run scripts to perform batch management tasks on a particular storage array. For example, scripts might be run to create new volumes or to download new controller firmware. For more information on running scripts, refer to the online help topics in the EMW.
- Upgrade the controller firmware.

A local configuration file stores all of the information about storage arrays that you have added and any email destinations or SNMP traps that you have configured.

Parts of the Enterprise Management Window

The Enterprise Management Window (EMW) has these areas that provide options for managing your storage array.

| Part | Description |
|-----------|---|
| Title bar | "Enterprise Management" in the title bar text indicates that this is the EMW. |

| Part | Description |
|------------|--|
| Menu bar | The menu bar contains various options to manage the storage arrays. For more information about menu bar options, refer to the EMW Menu Bar Options online help topic in the Enterprise Management Window of SANtricity ES Storage Manager. |
| Toolbar | The toolbar contains icons that are shortcuts to common commands. To show the toolbar, select View > Toolbar . |
| Tabs | The EMW contains two tabs: <ul style="list-style-type: none"> ▪ Devices – Shows the discovered storage arrays and their status and also shows unidentified storage arrays. ▪ Setup – Allows you to perform initial setup tasks with the storage management software. |
| Status bar | The Status bar shows a summary of the health of your storage arrays, messages, and a progress bar. To show the Status bar, select View > Status Bar . |

EMW Devices Tab

The **Devices** tab in the EMW presents two views of the storage arrays that are managed by the storage management station:

- Tree view
- Table view

Tree View

The Tree view provides a tree-structured view of the nodes in the storage system. The Tree view shows two types of nodes:

- Discovered Storage Arrays
- Unidentified Storage Arrays

Both the Discovered Storage Arrays node and the Unidentified Storage Arrays node are child nodes of the storage management station node.

The Discovered Storage Arrays node has child nodes that represent the storage arrays that are currently managed by the storage management station. Each storage array is labeled with its machine name and is always present in the Tree view. When storage arrays and hosts with attached storage arrays are added to the EMW, the storage arrays become child nodes of the Discovered Storage Arrays node.



NOTE If you move the mouse over the storage array node, a tooltip shows the controller's IP address.

The Unidentified Storage Arrays node shows storage arrays that the storage management station cannot access because the name or IP address does not exist.

You can perform these actions on the nodes in the Tree view:

- Double-click the storage management station node and the Discovered Storage Arrays node to expand or collapse the view of the child nodes.
- Double-click a storage array node to launch the Array Management Window for that storage array.
- Right-click a node to open a pop-up menu that contains the applicable actions for that node.

The right-click menu for the Discovered Storage Arrays node contains these options:

- **Add Storage Array**
- **Automatic Discovery**
- **Refresh**

These options are the same as the options in the **Tools** menu. For more information, refer to the online help topics in the Enterprise Management Window.

Table View

Each managed storage array is represented by a single row in the Table view. The columns in the Table view show data about the managed storage array.

| Column | Description |
|------------------------|---|
| Name | The name of the managed storage array. If the managed storage array is unnamed, the default name is Unnamed. |
| Type | The type of managed storage array. This type is represented by an icon. |
| Status | An icon and a text label that report the status of the managed storage array. |
| Management Connections | Out-of-Band – This storage array is an out-of-band storage array. In-Band – This storage array is an in-band storage array that is managed through a single host. Out-of-Band, In-Band – This storage array is a storage array that is both out-of-band and in-band. Click Details to see more information about any of these connections. |
| Comment | Any comments that you have entered about the specific managed storage array. |

Sort the rows in the Table view in ascending order or descending order by either clicking a column heading or by selecting one of these commands:

- **View > By Name**
- **View > By Status**
- **View > By Management Connection**
- **View > By Comment**

Showing Managed Storage Arrays in the Table View

You can change the way that managed storage arrays appear in the Table view.

- Select the storage management station node to show all of the known managed storage arrays in the Table view.
- Select a Discovered Storage Array node or an Undiscovered Storage Array node in the Tree view to show any storage arrays that are attached to that specific host in the Table view.



NOTE If you have not added any storage arrays, the Table view is empty.

- Select a storage array node in the Tree view to show only that storage array in the Table view.



NOTE Selecting an Unidentified node in the Tree view shows an empty Table view.

EMW Setup Tab

The EMW **Setup** tab is a gateway to tasks that you can perform when you set up a storage array. Using the EMW **Setup** tab, you can perform these tasks:

- Add a storage array
- Name or rename a storage array
- Configure an alert
- Manage a storage array by launching the Array Management Window (AMW)
- Upgrade the controller firmware
- Open the **Inherit Systems Settings** window

Adding and Removing a Storage Array

You can add a storage array by using these methods in the storage management software.

| Location | Procedure |
|------------------|---|
| Tree view | Right-click the root node from the Tree view, and select Add Storage Array from the pop-up menu. |
| Toolbar | Click the icon to add the storage array.  |
| Edit menu | Select Edit > Add Storage Array . |
| Setup tab | Select Add Storage Array . |

You can remove a storage array by using these methods, which remove only the icon from the view without physically deleting the storage array. You can select more than one storage array to delete at a time.

| Location | Procedure |
|------------------|---|
| Tree view | Right-click the storage array that you want to remove from the Tree view, and select Remove > Storage Array from the pop-up menu. |
| Toolbar | Select the storage array that you want to remove from the Tree view or Table view, and click the icon to remove the storage array.  |
| Edit menu | Select the storage array that you want to remove from the Tree view or Table view, and select Edit > Remove > Storage Array . |

Array Management Window

The Array Management Window (AMW) is a Java™ technology-based software that is launched from the Enterprise Management Window (EMW). The AMW provides management functions for a single storage array. You can have more than one AMW open at the same time to manage different storage arrays. The AMW includes these management functions for a storage array:

- Provides storage array options, such as locating a storage array, configuring a storage array, renaming a storage array, or changing a password.
- Provides the ability to configure volumes from your storage array capacity, define hosts and host groups, and grant host or host group access to sets of volumes called storage partitions.
- Monitors the health of storage array components and reports a detailed status using applicable icons.
- Provides you with the applicable recovery procedures for a failed logical component or a failed hardware component.
- Presents a view of the Event Log for the storage array.
- Presents profile information about hardware components, such as controllers and drives.
- Provides controller management options, such as changing ownership of volumes or placing a controller online or offline.
- Provides drive management options, such as assigning hot spares and locating the drive.
- Monitors storage array performance.

Starting the Array Management Window

To start the Array Management Window (AMW) from the Enterprise Management Window (EMW), perform one of these tasks:

- Click the **Devices** tab, and double-click the name of the storage array that you want to manage.
- Click the **Devices** tab, right-click the name of the storage array you want to manage, and select **Manage Storage Array**.
- Click the **Devices** tab, and select **Tools > Manage Storage Array**.
- Click the **Setup** tab, and select **Manage a Storage Array**. In the **Select Storage Array** dialog, select the name of the storage array that you want to manage, and click **OK**.

Summary Tab

The **Summary** tab in the AMW shows information about the storage array. Links to the **Storage Array Profile** dialog, relevant online help topics, and the storage concepts tutorial also appear. Additionally, the link to the **Recovery Guru** dialog appears when the storage array needs attention.

In the **Summary** tab, you can view this information:

- The status of the storage array
- The hardware components in the storage array
- The capacity of the storage array
- The hosts, the mappings, and the storage partitions in the storage array
- The volume groups and volumes in the storage array

Logical Tab

The **Logical** tab in the AMW contains two panes: the Logical pane and the Properties pane.

 **NOTE** You can resize either pane by dragging the splitter bar, located between the two panes, to the right or to the left.

Logical Pane

The Logical pane provides a tree-structured view of the logical nodes. Click the plus (+) sign or the minus (-) sign adjacent to a node to expand or collapse the view. You can right-click a node to open a pop-up menu that contains the applicable actions for that node.

Nodes in the Logical Pane

The storage array, or root node, has three types of child nodes.

| Child Nodes of the Root Node | Description of the Child Nodes |
|------------------------------|--|
| Unconfigured Capacity | This node represents the storage array capacity that is not configured into a volume group. |
| Volume Group | This node has two types of child nodes: <ul style="list-style-type: none"> ▪ Volume – This node represents a configured and defined volume. Multiple Volume nodes can exist under a Volume Group node. ▪ Free Capacity – This node represents a region of capacity that you can use to create one or more new volumes within the volume group. Multiple Free Capacity nodes can exist under a Volume Group node. |

 **NOTE** Multiple Unconfigured Capacity nodes appear if your storage array contains drives with different media types (hard drive or Solid State Disk [SSD]) and different interface types. Each drive type has an associated Unconfigured Capacity node shown under the Total Unconfigured Capacity node if unassigned drives are available in the drive tray.

Types of Volumes

These types of volumes appear under the Volume Group node:

- Standard volumes is the basic structure that you create in the storage array to store data. A volume is configured from a volume group with a specific RAID level to meet the software application's needs for data availability and I/O performance. The operating system sees a volume as one drive.
- Primary volumes that participate in a mirror relationship in the primary role. Primary volumes are standard volumes with a synchronized mirror relationship. The remote secondary volume that is associated with the primary volume appears as a child node.
- Secondary volumes appear directly under the Volume Group node when the local storage array contains this volume.
- Mirror repository volumes are special volumes in the storage array that are created as a resource for each controller in both local storage arrays and remote storage arrays. The controller stores duplicate information on the mirror repository volume, including information about remote writes that are not yet written to the secondary volume.

- Snapshot repository volumes is a volume in the storage array that is used as a resource for a snapshot volume.
- Snapshot volumes are child nodes of their associated base volume.
- Source volumes are standard volumes that participate in a volume copy relationship. Source volumes are used as the copy source for a target volume. Source volumes accept host I/O requests and store application data. A source volume can be a standard volume, a snapshot volume, a snapshot base volume, or a Remote Volume Mirroring primary volume.
- Target volumes are standard volumes that participate in a volume copy relationship and contain a copy of the data from the source volume. Target volumes are read-only and do not accept write requests. A target volume can be created from a standard volume, the base volume of a snapshot volume, or a Remote Volume Mirror primary volume. The volume copy overwrites any existing volume data if an existing volume is used as a target.

Properties Pane

The Properties pane provides detailed information about the component selected in the Logical pane. The information varies depending on what type of component is selected.

You can view the physical components that are associated with a logical component by selecting the **Logical** tab, right-clicking a component, and selecting **View Associated Physical Components**.

Physical Tab

The **Physical** tab in the Array Management Window contains two panes: the Physical pane on the left and the Properties pane on the right.



NOTE You can resize either pane by dragging the splitter bar, located between the two panes, to the right or to the left.

The Physical pane provides a view of the hardware components in a storage array, including their status. You can right-click a hardware component to open a pop-up menu that contains the applicable actions for that component.









NOTE The icons that you see might differ from what is shown in this topic because the icons are determined by the hardware that is installed in your storage array. For example, the controller tray icon and the drive tray icon look like the actual controller trays and drive trays that are installed. Also, the drive icons are either horizontal or vertical to match the orientation of the physical drives in the drive tray.

The Properties pane provides information for the hardware component that is selected in the Physical pane. The information in the Properties pane is specific to each hardware component. If you select a controller icon in the Physical pane, a list of properties for that controller is shown in the Properties pane. If you select a drive icon in the Physical pane, a list of properties for that drive is shown in the Properties pane.

Controller Status

The status of each controller is indicated by an icon in the Physical pane. This table describes the various controller icons. Depending on your hardware model, the icons might differ from the icons shown in this table.

| Icon | Status |
|---|---|
|  | Online, Optimal |
|  | Offline |
|  | Service Mode |
|  | Slot Empty |
|  | Unsupported |
|  | Needs Attention (if applicable for your hardware model) |
|  | Suspended (if applicable for your hardware model) |

View Tray Components

The **View Tray Components** command on each tray shows the status of the secondary components within the tray, such as power supplies, fans, and temperature sensors.





Drive Trays

For each drive tray that is attached to the storage array, a drive tray appears in the Physical pane. If your storage array contains different media types or different interface types, a drive type icon appears to indicate the type of drives in the drive tray. This table describes the different drive type icons that might appear.

| Icon | Status |
|---|--|
|  | This drive tray contains only hard drives. |

| Icon | Status |
|---|---|
|  | This drive tray contains only Solid State Disks (SSDs). |

This table describes the different drive interface type icons that might appear.

| Icon | Status |
|---|---|
|  | This drive tray contains only full disk encryption (FDE) security capable drives. |
|  | This drive tray contains only Serial Attached SCSI (SAS) drives. |
|  | This drive tray contains only Fibre Channel (FC) drives. |
|  | This drive tray contains only Serial ATA (SATA) drives. |
|  | This drive tray contains only Data Assurance (DA) - capable drives. |

You can use the **Show** option in the Physical pane to identify drives of a particular type, speed, and capacity. In the **Drive type** drop-down list, select the type of drive you want to identify, and click **Show**. A green triangle appears on top of the relevant drives.

Mappings Tab

The **Mappings** tab in the AMW contains two panes: the Topology pane and the Defined Mappings pane.



NOTE You can resize either pane by dragging the splitter bar, located between the two panes, to the right or to the left.

Topology Pane

The Topology pane shows a tree-structured view of logical nodes that are related to storage partitions. Click the plus (+) sign or the minus (-) sign adjacent to a node to expand or collapse the view. You can right-click a node to open a pop-up menu that contains the applicable actions for that node.

Nodes in the Topology Pane

The storage array, or the root node, has these types of child nodes.

| Child Nodes of the Root Node | Description of the Child Nodes |
|-----------------------------------|--|
| Undefined Mappings | The Undefined Mapping node has one type of child node. Individual Undefined Mapping – Represents a volume with an undefined mapping. Multiple Volume nodes can exist under an Undefined Mappings node. |
| Default Group | NOTE If SANshare Storage Partitioning is disabled, all of the created volumes are in the Default Group. A Default Group node has two types of child nodes: <ul style="list-style-type: none"> ▪ Host Group – Defined host groups that are not participating in specific mappings are listed. This node can have host child nodes, which can have child host port nodes. ▪ Host – Defined hosts that are not part of a specific host group but are part of the Default Group and are not participating in specific mappings are listed. This node can have child host port nodes. |
| Unassociated Host Port Identifier | An Unassociated Host Port Identifier node has one type of child node. Host Port Identifier – Host port identifier that has not been associated with any host. |
| Host Group | A Host Group node has one type of child node. Host – Defined hosts that belong to this defined host group are listed. This node can have child host port nodes. NOTE The host nodes that are child nodes of this host group can also participate in mappings specific to the individual host rather than the host group. |
| Host | A Host node has one type of child node. Host Port – This node has child nodes that represent all of the host ports or single ports on a host adapter that are associated with this host. |

Storage Partition Icon

The storage partition icon, when present in the Topology pane, indicates that a storage partition has been defined for a host group, or a host. This icon also appears in the status bar when storage partitions have been defined.



Defined Mappings Pane

The Defined Mappings pane shows the mappings associated with a node selected in the Topology pane.

The information in the table appears for a selected node.

| Column Name | Description |
|-------------|---|
| Volume Name | The user-supplied volume name. The factory-configured access volume also appears in this column. |

| Column Name | Description |
|-----------------|--|
| | NOTE An access volume mapping is <i>not</i> required for a storage array with an in-band connection and can be removed. |
| Accessible By | Shows the Default Group, a defined host group, or a defined host that has been granted access to the volume in the mapping. |
| LUN | The LUN assigned to the specific volume that the host or hosts use to access the volume. |
| Volume Capacity | Shows the volume capacity in units of GB. |
| Type | Indicates whether the volume is a standard volume or a snapshot volume. |

You can right-click a volume name in the Defined Mappings pane to open a pop-up menu. The pop-up menu contains options to change and remove the mappings.

The information shown in the Defined Mappings pane varies according to what node you select in the Topology pane, as shown in this table.

| Node Selected | Information That Appears in the Defined Mappings Pane |
|--|---|
| Root (storage array) node | All defined mappings. |
| Default Group node or any child node of the Default Group | All mappings that are currently defined for the Default Group (if any). |
| Host Group node (outside of Default Group) | All mappings that are currently defined for the Host Group. |
| Host node that is a child node of a Host Group node | All mappings that are currently defined for the Host Group, plus any mappings specifically defined for a specific host. |
| Host Port node or individual host port node outside of the Default Group | All mappings that are currently defined for the host port's associated host. |

AMW Setup Tab

The AMW **Setup** tab provides links to these tasks:

- Locating the storage array
- Renaming the storage array
- Setting a storage array password
- Configuring the network parameters for the iSCSI host ports
- Configuring the storage array
- Mapping volumes to hosts
- Saving configuration parameters in a file
- Defining the hosts and host ports
- Configuring the Ethernet management ports

- Viewing and enabling the premium features
- Managing the additional iSCSI settings for authentication, identification, and discovery

The iSCSI options are shown in the AMW **Setup** tab only when the controllers contain iSCSI host ports.

Support Tab

The **Support** tab in the AMW provides links to these tasks:

- Recovering from a storage array failure by using the Recovery Guru
- Gathering support information, such as the Event Log and a description of the storage array, to send to your Customer and Technical Support representative
- Viewing the description of all components and properties of the storage array
- Downloading the controller firmware, the NVSRAM, the drive firmware, the ESM firmware, and the ESM configuration settings
- Viewing the Event Log of the storage array
- Viewing the online help topics
- Viewing the version and copyright information of the storage management software

You can click a link to open the corresponding dialog.

Managing Multiple Software Versions

When you open the Array Management Window (AMW) to manage a storage array, the version of software that is appropriate for the version of firmware that the storage array uses is opened. For example, you manage two storage arrays using this software; one storage array has firmware version 6.14, and the other has firmware version 7.8x, where x represents a number. When you open the AMW for a particular storage array, the correct AMW version is used. The storage array with firmware version 6.14 uses version 9.14 of the storage management software, and the storage array with firmware version 7.8x uses version 10.8x of the storage management software. You can verify the version that you are currently using by selecting **Help>About** in the AMW.

This bundling of previous versions of the AMW provides the flexibility of upgrading the firmware only on selected storage arrays instead of having to perform an upgrade on all of the storage arrays at one time.

Configuring the Storage Arrays

The topics in this section describe the methods for configuring storage arrays, including managing security, and premium features.

For additional information and detailed procedures for the options described in this section, refer to the online help topics in SANtricity ES Storage Manager.

Volumes and Volume Groups

When you configure a storage array for the first time, you must consider which data protection strategy is most appropriate for your storage array, together with how the total storage capacity must be organized into volumes and shared among hosts.

The storage management software identifies several distinct volumes:

- Standard volumes
- Snapshot volumes
- Snapshot repository volumes
- Primary volumes
- Secondary volumes
- Mirror repository volumes
- Source volumes
- Target volumes

Standard Volumes

A standard volume is a logical structure that is created on a storage array for data storage. A standard volume is defined from a set of drives called a volume group, which has a defined RAID level and capacity. You can create a volume from unconfigured capacity, unassigned drives, or Free Capacity nodes on the storage array. If you have not configured any volumes on the storage array, the only node that is available is the Unconfigured Capacity node.

Use the Create Volume Wizard to create one or more volumes on the storage array. During the volume creation process, the wizard prompts you to select the capacity to allocate for the volumes and to define basic volume parameters and optional advanced volume parameters for the volume.



IMPORTANT The host operating system might have specific limits about how many volumes that the host can access. You must consider these limits when you create volumes that are used by a particular host.

| Storage Array | Maximum Number of Volumes per Storage Array | Maximum Number of Volumes per Storage Partition |
|------------------------------|---|---|
| CE5400 controller-drive tray | Up to 2048 | Up to 256 |
| CE7900 controller tray | Up to 2048 | Up to 256 |
| CE2600 controller-drive tray | Up to 512 | Up to 256 |
| CE4900 controller-drive tray | Up to 1024 | Up to 256 |

Volume Groups

A volume group is a set of drives that the controller logically groups together to provide one or more volumes to an application host. All of the drives in a volume group must have the same media type and interface type.

To create a volume group, you must specify two key parameters: the RAID level and the capacity (how large you want the volume group to be). You can either select the automatic choices provided by the software or select the manual method to indicate the specific drives to include in the volume group. Whenever possible, use the automatic method because the storage management software provides the best selections for drive groupings.

Volume Group Creation

The Create Volume Group Wizard guides you through the steps to create one or more volume groups in a storage array and to configure basic volume group parameters and optional volume group parameters.



IMPORTANT The storage management software determines the default initial capacity selections based on whether you select free capacity, unconfigured capacity, or unassigned drives in the Create Volume Group Wizard. After the wizard begins, you can change the capacity by defining a new volume capacity.

You can organize available capacity on a storage array by using these types of storage spaces:

- **Free capacity** – Free capacity is unassigned space in a volume group that you can use to create a volume. When you create a volume from free capacity, an additional volume is created on an existing volume group.
- **Unconfigured capacity** – Unconfigured capacity is available space on drives of a storage array that has not been assigned to a volume group. One unconfigured capacity node exists for each type of drive media and drive interface.
- **Unassigned drive** – An unassigned drive is a drive that is not being used in a volume group or is not assigned as a hot spare.

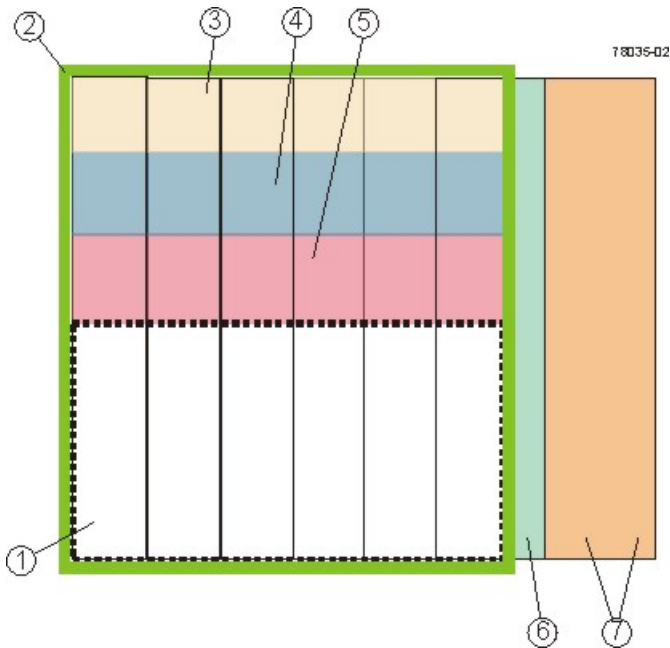

- 1. Free Capacity
- 2. Volume Group
- 3. Volume
- 4. Volume
- 5. Volume
- 6. Hot Spare Drive
- 7. Unconfigured Capacity

Specifying Volume Parameters

| Parameter | Free Capacity | Unconfigured Capacity | Unassigned Drive |
|--|--|--|--|
| Volume Group Creation | The volume group is predefined. | You must create a volume group before configuring a new volume. | You must create a volume group before configuring a new volume. |
| Specify Capacity/ Name Dialog | Assign a name to the volume. Change the default capacity. | Assign a name to the volume. Change the default capacity. | Assign a name to the volume. Change the default capacity. |
| Storage Partitioning will be used | Select the Map Later using the Mappings View option. This option specifies that a LUN not be assigned to the volume during volume creation. This option defines specific mappings and creates storage partitions. | Select the Map Later using the Mappings View option. This option specifies that a LUN not be assigned to the volume during volume creation. This option defines specific mappings and creates storage partitions. | Select the Map Later using the Mappings View option. This option specifies that a LUN not be assigned to the volume during volume creation. This option defines specific mappings and creates storage partitions. |

| Parameter | Free Capacity | Unconfigured Capacity | Unassigned Drive |
|--|---|---|---|
| Storage Partitioning will not be used | Select the Default Mapping option. This option automatically assigns the next available LUN in the Default Group to the volume. The option grants volume access to host groups or hosts that have no specific mappings, which are shown under the Default Group node in the Topology pane. | Select the Default Mapping option. This option automatically assigns the next available LUN in the Default Group to the volume. The option grants volume access to host groups or hosts that have no specific mappings, which are shown under the Default Group node in the Topology pane. | Select the Default Mapping option. This option automatically assigns the next available LUN in the Default Group to the volume. The option grants volume access to host groups or hosts that have no specific mappings, which are shown under the Default Group node in the Topology pane. |
| Advanced Volume Parameters | You can customize these advanced volume parameters: <ul style="list-style-type: none"> ▪ Volume I/O characteristics ▪ Preferred controller owner | You can customize these advanced volume parameters: <ul style="list-style-type: none"> ▪ Volume I/O characteristics ▪ Preferred controller owner | You can customize these advanced volume parameters: <ul style="list-style-type: none"> ▪ Volume I/O characteristics ▪ Preferred controller owner |

Dynamic Capacity Expansion

Dynamic Capacity Expansion (DCE) is a modification operation in the storage management software that increases the capacity of a volume group. This modification operation allows you to add unassigned drives to a volume group. Adding unassigned drives increases the free capacity in the volume group. You can use this free capacity to create additional volumes.

This operation is considered to be dynamic because you have the ability to continually access data in the volume group throughout the entire operation.

Keep these guidelines in mind when you add unassigned drives to a volume group:

- The number of unassigned drives that you can select for a DCE modification operation is limited by the controller firmware. You can add two unassigned drives at a time. However, after you have completed a DCE operation, you can add more drives again until the desired capacity is reached.
- The existing volumes in the volume group do not increase in size when you add unassigned drives to expand the free capacity. This operation redistributes existing volume capacity over the larger number of drives in the volume group.
- The unassigned drives that you are adding to the volume group must be of the same media type and interface type. Mixing different drive types within a single volume group is not permitted. Whenever possible, select drives that have a capacity equal to the capacities of the current drives in the volume group.
- In a RAID Level 1 volume group, you must add two drives to make sure that data redundancy is configured.
- Only security capable drives can be added to a security enabled volume group or a security capable volume group.
- In a volume group that is Data Assurance (DA) capable and contains a DA-enabled volume, you can add only DA-capable drives.

Register the Volume with the Operating System

After you have created all of your volumes and have assigned mappings, use a volume registration utility, such as the `hot_add` utility when using RDAC, to scan the mapped volumes and register the volumes with the operating system.

You can run the `hot_add` utility to make sure that the operating system is aware of the newly created volumes.

If available for your operating system, you can run the host-based `SMdevices` utility to associate the physical storage array name and the volume name.

Premium Features

The storage management software has the following premium features that provide data-protection strategies:

- SANshare Storage Partitioning
- Snapshot Volume
- Remote Volume Mirroring (this premium feature is supported only in storage arrays with the Fibre Channel [FC] host ports)
- Volume Copy
- SafeStore Drive Security and SafeStore Enterprise Key Manager
- SafeStore Data Assurance (DA)
- Solid State Disks (SSDs)

SANshare Storage Partitioning

SANshare Storage Partitioning lets hosts with different operating systems share access to a storage array. Hosts with different operating systems that share access to a storage array are called heterogeneous hosts.

A storage partition is a logical entity that consists of one or more storage array volumes that can be shared among hosts. To create a storage partition after the total storage capacity has been configured into volumes, you must define a single host or collection of hosts (or host group) that will access the storage array. Then you must define a mapping, which lets you specify the host group or the host that will have access to a particular volume in your storage array.

Based on the premium feature key file purchased, the storage management software can support the maximum storage partitions shown in this table.

| Storage Array | Maximum Number of Storage Partitions Supported |
|------------------------------|--|
| CE5400 controller-drive tray | Up to 512 |
| CE7900 controller tray | Up to 512 |
| CE2600 controller-drive tray | Up to 128 |
| CE4900 controller-drive tray | Up to 128 |

You can define a maximum of 256 volumes per partition (except for the HP-UX 11.23 operating system); this number is limited to the total number of volumes on your storage array.

Snapshot Volume Premium Feature

The Snapshot Volume premium feature creates a logical point-in-time image of another volume. Snapshot Volume is a premium feature of the storage management software. You or your storage vendor must enable this premium feature.

Because the only data blocks that are physically stored in the snapshot repository volume are those that have changed since the time that the snapshot volume was created, the snapshot volume uses less drive space than a full physical copy.

Typically, you create a snapshot so that an application (for example, a backup application) can access the snapshot and read the data; meanwhile, the base volume stays online and is user accessible. When the backup is completed, the snapshot volume is no longer needed.

You can also create snapshots of a base volume and write data to the snapshot volumes to perform testing and analysis. Before upgrading your database management system, for example, you can use snapshot volumes to test different configurations. Then you can use the performance data that is provided by the storage management software to help you decide how to configure your live database system. The maximum number of snapshots supported by the storage array is shown in this table.

| Storage Array | Maximum Number of Snapshots per Volume | Maximum Number of Snapshots per Storage Array |
|------------------------------|--|---|
| CE5400 controller-drive tray | Up to 16 | Up to 1024 |
| CE7900 controller tray | Up to 16 | Up to 1024 |
| CE2600 controller-drive tray | Up to 16 | Up to 256 |
| CE4900 controller-drive tray | Up to 8 | Up to 512 |

Creating Snapshot Volumes

When a snapshot volume is created, the controller suspends I/O activity to the base volume for a few seconds while it creates a physical volume, called the snapshot repository volume. The snapshot repository volume stores the snapshot volume metadata and the copy-on-write data.

You can create snapshot volumes by using the Create Snapshot Volume Wizard in the Array Management Window. The first dialog of the Create Snapshot Volume Wizard lets you select either the simple path or the advanced path to be followed through the wizard. You can choose the simple path to create a snapshot volume if the volume group of the base volume has the required amount of free capacity. The simple path lets you specify the basic parameters for the snapshot volume. The simple path accepts the default settings for the advanced parameters.



NOTE If sufficient free capacity is not available in the volume group of the base volume, the Create Snapshot Volume Wizard uses the advanced path by default.

In the advanced path, either you can choose to place the snapshot repository volume in another volume group, or you can use unconfigured capacity in the storage array to create a new volume group. The advanced path lets you customize the advanced settings for the snapshot volume, such as the full conditions of the snapshot repository volume and the notification settings.

If you want to create a snapshot volume that performs snapshot operations at a later time or at regularly occurring intervals, specify a schedule. If you do not specify a schedule, the snapshot operation occurs immediately.

Scheduling Snapshots

If you want to create a snapshot volume that performs snapshot operations at a later time or at regularly occurring intervals, add a schedule to the snapshot volume. If you do not add a schedule to the snapshot volume, the snapshot operation occurs immediately. You can add a schedule when you create a snapshot volume, or you can add a schedule to an existing snapshot volume. Each snapshot volume can have only one schedule.

Typical Uses of Scheduling Snapshots

Scheduled backups – For example, an application stores business-critical data in two volumes in the storage array. You back up this data every work day at 11:00 p.m. To accomplish this type of backup, select the first volume. Create a schedule that runs once a day on Monday, Tuesday, Wednesday, Thursday, and Friday. Choose a time between the end of your work day and 11:00 p.m. Select a starting date of today and no end date. Apply this schedule to the second volume, also. Map the two snapshot volumes to your backup host, and perform the regular backup procedures. Unmap the two snapshot volumes before the next scheduled snapshot operation time. If you do not unmap the snapshot volumes, the storage array skips the next snapshot operation to avoid data corruption.

Rapid recovery – In this example, you back up your data at the end of every work day and keep hourly snapshots from 8:00 a.m. to 5:00 p.m. If data loss or corruption occurs during the work day, you can recover the data from the snapshots so that the data loss window is smaller than one hour. To accomplish this type of recovery, create a schedule that contains a start time of 8:00 a.m. and an end time of 5:00 p.m. Select 10 snapshots per day on Monday, Tuesday, Wednesday, Thursday, and Friday. Select a start date of today and no end date. Create an end-of-day backup as described in the "Scheduled backups" example.



Guidelines for Creating Schedules

Keep the following guidelines in mind when creating schedules for snapshot volumes:

- Either you can create a schedule when you create a snapshot volume, or you can add a schedule to an existing snapshot volume.
- Scheduled snapshot operations do not take place when these conditions occur:
 - The snapshot volume is mapped.
 - The storage array is offline or powered off.
 - The snapshot volume is used as a source volume in a Volume Copy operation, and the status of the copy operation is Pending or In progress.
- If you delete a snapshot volume that has a schedule, the schedule is also deleted.
- Schedules are stored in the configuration database in the storage array. The management station does not need to be running the Enterprise Management Window (EMW) or the Array Management Window (AMW) for the scheduled snapshot operation to occur.

Enabling and Disabling Schedules

You temporarily can suspend scheduled snapshot operations by disabling the schedule. When a schedule is disabled, the schedule's timer continues to run, but the scheduled snapshot operations do not occur. This table shows the icons for scheduled snapshots.

| Icon | Description |
|---|---|
|  | The schedule is enabled. Scheduled snapshots will occur. |
|  | The schedule is disabled. Scheduled snapshots will not occur. |

Discontinuing the Use of a Snapshot Volume

As long as a snapshot volume is enabled, storage array performance is affected by the copy-on-write activity to the associated snapshot repository volume. When you no longer need a snapshot volume, you can disable it, reuse it, or delete it.

- **Disable** – Stops copy-on-write activity. This option keeps the snapshot volume and snapshot repository volume intact.
- **Reuse** – Creates a different point-in-time image of the same base volume. This action takes less time to configure than re-creating the snapshot volume.
- **Delete** – Completely removes the snapshot volume and the associated snapshot repository volume. If you want to re-enable a snapshot volume, you must re-create it.

Disabling and Restarting Multiple Snapshots

If multiple volumes require regular snapshots for backup purposes, keeping the snapshots enabled might significantly affect storage array performance. In this situation, you can disable the snapshot function for multiple volumes and then restart the snapshots for all of the volumes before the next backup is scheduled.

The list of snapshots to be restarted is treated as a single operation. The new point-in-time snapshot images are created from the previously defined parameters. If an error is encountered on any of the listed snapshots, none of the snapshots on the list are re-created.

Snapshot Rollback

You can use the snapshot rollback feature for changing the content of a base volume to match the point-in-time image that is saved in a snapshot volume. The host can continue to access the base volume for I/O operations during the rollback operation.

 **NOTE** The snapshot rollback feature is supported only in SANtricity ES Storage Manager Version 10.80.

The snapshot volume is set as read-only during the rollback operation. The snapshot volume becomes available for write operations after the rollback operation is completed. You cannot restart, delete, or disable the snapshot volume during a rollback operation. The associated snapshot repository volume must have sufficient capacity to process the rollback operation and the write operations from the host.

 **NOTE** The content in the snapshot volume might have changed after the creation of the snapshot volume because of write operations from the host. The rollback operation also copies these changes to the base volume.

You can set the priority for a rollback operation. Higher priority allocates more system resources for the rollback operation and might affect the overall system performance.

Keep these guidelines in mind before you start a rollback operation:

- The rollback operation does not change the content of the snapshot volumes that are associated with the base volume.
- You cannot start more than one rollback operation for a base volume at a time.
- You cannot create new snapshot volumes for a base volume that is participating in a rollback operation.
- You cannot start a rollback operation when any of these operations are in progress in the storage array:
 - Dynamic Capacity Expansion (DCE) to increase the capacity of a volume group
 - Dynamic Volume Expansion (DVE) to increase the capacity of a volume
 - Dynamic RAID Migration (DRM) to change the RAID level of a volume group
 - Dynamic Segment Size (DSS) to change the segment size of a volume
- You cannot start a rollback operation if the base volume is participating in a volume copy.
- You cannot start a rollback operation if the base volume is a secondary volume in a remote mirror. However, if the base volume is the primary volume in a remote mirror, you can start a rollback operation. Additionally, you cannot perform a role reversal in a remote mirror if the primary volume is participating in a rollback operation.
- A rollback operation fails if any of the used capacity in the associated snapshot repository volume has unreadable sectors.

The rollback operation is paused if an error occurs during the rollback operation. The base volume and the snapshot volume display Needs Attention icons, and the controller logs the event to the Major Event Log (MEL). You can follow the Recovery Guru procedure to correct the problem and then try to resume the rollback operation.



ATTENTION Risk of data loss – You can cancel a rollback operation, but this action leaves the base volume in an unusable state, and the snapshot volume appears as failed in the storage management software. Therefore, you must consider canceling a rollback operation only when recovery options exist for restoring the content of the base volume.

You also can use the command line interface (CLI) to start a rollback operation, cancel a rollback operation, resume a rollback operation, modify the priority of a rollback operation, and view the progress of a rollback operation.

Recovering from a Failed Rollback Operation

Prior to starting a rollback operation, you can create a new snapshot volume from the base volume. If the rollback operation from a snapshot volume fails, you can use the new snapshot volume as a source in a rollback operation and restore the content of the base volume.

Snapshot Volumes from Prior Versions of the Storage Management Software

If the snapshot volumes were created using a prior version of the storage management software that did not support the snapshot rollback feature, you can upgrade the version of the storage management software and the version of the controller firmware. After the upgrade, the snapshot volumes will support the rollback feature. However, if you revert to an older version of the storage management software after a rollback operation, the storage management software will not support the snapshot volume.

Dynamic Volume Expansion

 **IMPORTANT** Increasing the capacity of a standard volume is only supported on certain operating systems. If volume capacity is increased on a host operating system that is not supported, the expanded capacity is unusable, and you cannot restore the original volume capacity.

Dynamic Volume Expansion (DVE) is a modification operation that increases the capacity of standard volumes or snapshot repository volumes. The increase in capacity can be achieved by using any free capacity available on the volume group of the standard volume or the snapshot repository volume. Data is accessible on volume groups, volumes, and drives throughout the entire modification operation.

If you receive a warning that the snapshot repository volume is in danger of becoming full, you can use the DVE modification operation to increase the capacity of the snapshot repository volume.

Increasing the capacity of a snapshot repository volume does not increase the capacity of the associated snapshot volume. The capacity of the snapshot volume is always based on the capacity of the base volume at the time that the snapshot volume was created.

Remote Volume Mirroring Premium Feature

The Remote Volume Mirroring premium feature is used for online, real-time data replication between storage arrays over a remote distance. Storage array controllers manage the mirroring, which is transparent to host machines and software applications. You create one or more mirrored volume pairs that consist of a primary volume at the primary site and a secondary volume at a secondary, remote site. After you create the mirror relationship between the two volumes, the current owner of the primary volume copies all of the data from the primary volume to the secondary volume. This process is called a full synchronization.

There is a base number of defined mirrors that are allowed for each storage array. You can increase the number of defined mirrors that are allowed for each model with the purchase of an optional feature pack upgrade key. This table shows the maximum number of defined mirrors to which you can upgrade with a feature pack upgrade key.

| Storage Array | Maximum Number of Defined Mirrors |
|------------------------------|-----------------------------------|
| CE5400 controller-drive tray | Up to 128 |
| CE7900 controller tray | Up to 128 |
| CE2600 controller-drive tray | Up to 16 |
| CE4900 controller-drive tray | Up to 64 |

The Remote Volume Mirroring premium feature is not supported in a simplex configuration. You must disable the Remote Volume Mirroring premium feature before converting a storage array from a duplex configuration to a simplex configuration. The Remote Volume Mirroring premium feature is supported only in storage arrays with Fibre Channel (FC) host ports. The Remote Volume Mirroring premium feature also requires a Fibre Channel network switch.

 **ATTENTION Possible loss of data access** – You cannot create a mirror relationship if the primary volume contains unreadable sectors. Furthermore, if an unreadable sector is discovered during a mirroring operation, the mirror relationship fails.



NOTE Because replication is managed on a per-volume basis, you can mirror individual volumes in a primary storage array to appropriate secondary volumes in several *different* remote storage arrays.

Disaster Recovery

The secondary, remote volume is unavailable to secondary host applications while mirroring is in progress. In the event of a disaster at the primary site, you can fail over to the secondary site. To fail over, perform a role reversal to promote the secondary volume to a primary volume. Then the recovery host is able to access the newly promoted volume, and business operations can continue.

Data Replication

When the current owner of the primary volume receives a write request from a host, the controller first logs information about the write to a special volume. This volume is called a mirror repository volume. It writes the data to the primary volume. Next, the controller initiates a remote write operation to copy the affected data blocks to the secondary volume at the remote site.

Finally, the controller sends an I/O completion indication back to the host system to confirm that the data was copied successfully to the secondary storage array. The write mode that you selected when you first created a remote volume mirror determines when the I/O completion indication is sent to the host system.

The storage management software provides two write modes:

- **Synchronous** – When you select this write mode, any host write requests are written to the primary volume and then copied to the secondary storage volume. The controller sends an I/O completion indication to the host system *after* the copy has been successfully completed.
- **Asynchronous** – When you select this write mode, host write requests are written to the primary volume. Then the controller sends an I/O completion indication back to the host system *before* the data has been successfully copied to the secondary storage array.

When write caching is enabled on either the primary volume or the secondary volume, the I/O completion is sent when data is in the cache on the side (primary or secondary) where write caching is enabled. When write caching is disabled on either the primary volume or the secondary volume, the I/O completion is not sent until the data has been stored to physical media on that side.

Host write requests received by the controller are handled normally. No communication takes place between the primary storage array and the secondary storage array.

Link Interruptions or Secondary Volume Errors

When processing write requests, the primary controller might be able to write to the primary volume, but a link interruption prevents communication with the remote secondary controller.

In this case, the remote write cannot complete to the secondary volume. The primary volume and the secondary volume are no longer appropriately mirrored. The primary controller changes the mirrored pair into Unsynchronized status and sends an I/O completion to the primary host. The primary host can continue to write to the primary volume, but remote writes do not take place.

When connectivity is restored between the current owner of the primary volume and the current owner of the secondary volume, a full synchronization takes place. Only the blocks of data that have changed on the primary volume during the link interruption are copied to the secondary volume. The mirrored pair changes from an Unsynchronized state to Mirror Synchronization in Progress status.

The primary controller also marks the mirrored pair as Unsynchronized when a volume error on the secondary side prevents the remote write from completing. For example, an offline secondary volume or a failed secondary volume can cause the remote mirror to become unsynchronized. When the volume error is corrected (the secondary volume is placed online or is recovered to Optimal status), a full synchronization automatically begins. The mirrored pair then changes to Synchronization in Progress status.

Connectivity and Volume Ownership

A primary controller attempts to communicate only with its matching controller in the secondary storage array. For example, controller A in the primary storage array attempts communication only with controller A in the secondary storage array. The controller (A or B) that owns the primary volume determines the current owner of the secondary volume. If the primary volume is owned by controller A on the primary side, the secondary volume is owned by controller A on the secondary side. If primary controller A cannot communicate with secondary controller A, controller ownership changes do not take place.

The next remote write processed automatically triggers a matching ownership change on the secondary side if one of these conditions exists:

- When an I/O path error causes a volume ownership change on the primary side
- If the storage administrator changes the current owner of the primary volume

For example, controller A owns a primary volume, and then you change the controller owner to controller B. In this case, the next remote write changes the controller owner of the secondary volume from controller A to controller B. Because controller ownership changes on the secondary side are controlled by the primary side, they do not require any special intervention by the storage administrator.

Controller Resets and Storage Array Power Cycles

Sometimes a controller reset or a storage array power cycle interrupts a remote write before it can be written to the secondary volume. The storage array controller does not need to perform a full synchronization of the mirrored volume pair in this case. A controller reset causes a controller ownership change on the primary side from the preferred controller owner to the alternate controller in the storage array. When a remote write has been interrupted during a controller reset, the new controller owner on the primary side reads information stored in a log file in the mirror repository volume of the preferred controller owner. The new controller owner then copies the affected data blocks from the primary volume to the secondary volume, which eliminates the need for a full synchronization of the mirrored volumes.

Remote Volume Mirroring Premium Feature Activation

Like other premium features, you enable the Remote Volume Mirroring premium feature by purchasing a feature key file from your storage supplier. You must enable the premium feature on both the primary storage array and the secondary storage array.

Unlike other premium features, you also must *activate* the premium feature after you enable it. To activate the premium feature, use the Activate Remote Volume Mirroring Wizard in the Array Management Window (AMW). Each controller in the storage array must have its own mirror repository volume for logging write information to recover from controller resets and other temporary interruptions. The Activate Remote Volume Mirroring Wizard guides you to specify the placement of the two mirror repository volumes (on newly created free capacity or existing free capacity in the storage array).

After you activate the premium feature, one Fibre Channel (FC) host side I/O port on each controller is solely dedicated to Remote Volume Mirroring operations. Host-initiated I/O operations are not accepted by the dedicated port. I/O requests received on this port are accepted only from remote controllers that are participating in Remote Volume Mirroring operations with the controller.

Connectivity Requirements

You must attach dedicated Remote Volume Mirroring ports to a Fibre Channel fabric environment. In addition, these ports must support the Directory Service interface and the Name Service.

You can use a fabric configuration that is dedicated solely to the Remote Volume Mirroring ports on each controller. In this case, host systems can connect to the storage arrays using fabric, Fibre Channel Arbitrated Loop (FC-AL), or point-to-point configurations. These configurations are totally independent of the dedicated Remote Volume Mirroring fabric.

Alternatively, you can use a single Fibre Channel fabric configuration for both the Remote Volume Mirroring connectivity and for the host I/O paths to the controllers.

The maximum distance between the primary site and the secondary site is 10 km (6.2 miles), using single-mode fiber gigabit interface converters (GBICs) and optical long-wave GBICs.

Restrictions

These restrictions apply to mirrored volume candidates and storage array mirroring:

- The RAID level, the caching parameters, and the segment size can be different on the two mirrored volumes.
- The secondary volume must be at least as large as the primary volume.
- The only type of volume that can participate in a mirroring relationship is a standard volume. Snapshot volumes cannot participate.
- You can create a snapshot volume by using either a primary volume or a secondary volume as the base volume.
- A primary volume can be a source volume or a target volume in a volume copy. A secondary volume cannot be a source volume or a target volume unless a role reversal was initiated after the volume copy has completed. If a role reversal is initiated during a Copy in Progress status, the volume copy fails and cannot be restarted.
- A given volume might participate in only *one* mirror relationship.

Volume Copy Premium Feature



ATTENTION Possible loss of data access – The volume copy operation overwrites existing data on the target volume and renders the volume read-only to hosts. This option fails all snapshot volumes that are associated with the target volume, if any exist.

The Volume Copy premium feature copies data from one volume (the source) to another volume (the target) in a single storage array.

Use the Volume Copy premium feature to perform these tasks:

- Copy data from volume groups that use smaller capacity drives to volume groups that use larger capacity drives.
- Create an online copy of data from a volume within a storage array, while still being able to write to the volume with the copy in progress.
- Back up data or restore snapshot volume data to the base volume.

Volume Copy is a premium feature of the storage management software and must be enabled either by you or your storage vendor.

| Storage Array | Maximum Number of Volume Copies per Storage Array |
|------------------------------|---|
| CE5400 controller-drive tray | Up to 2047 |
| CE7900 controller tray | Up to 2047 |
| CE2600 controller-drive tray | Up to 511 |
| CE4900 controller-drive tray | Up to 1023 |

Volume Copy Features

Data Copying for Greater Access

As your storage requirements for a volume change, use the Volume Copy premium feature to copy data to a volume in a volume group that uses larger capacity drives within the same storage array. This premium feature lets you perform these functions:

- Move data to larger drives; for example, 73 GB to 146 GB
- Change to drives with a higher data transfer rate; for example, 2 Gb/s to 4 Gb/s
- Change to drives using new technologies for higher performance

Data Backup

The Volume Copy premium feature lets you back up a volume by copying data from one volume to another volume in the same storage array. You can use the target volume as a backup for the source volume, for system testing, or to back up to another device, such as a tape drive.

Snapshot Volume Data Restoration to the Base Volume

If you need to restore data to the base volume from its associated snapshot volume, use the Volume Copy premium feature to copy data from the snapshot volume to the base volume. You can create a volume copy of the data on the snapshot volume, and then copy the data to the base volume.

 **ATTENTION Possible loss of data** – If you are using the Windows 2000 operating system or the Linux operating system, use the Volume Copy premium feature with the Snapshot Volume premium feature to restore snapshot volume data to the base volume. Otherwise, the source volume and the target volume can become inaccessible to the host.

Types of Volume Copies

You can perform either an *offline* volume copy or an *online* volume copy. To ensure data integrity, all I/O to the target volume is suspended during either volume copy operation. This suspension occurs because the state of data on the target volume is inconsistent until the procedure is complete. After the volume copy operation is complete, the target volume automatically becomes read-only to the hosts.

The offline and online volume copy operations are described as follows.

Offline Copy

An offline copy reads data from the source volume and copies it to a target volume, while suspending all updates to the source volume with the copy in progress. All updates to the source volume are suspended to prevent chronological inconsistencies from being created on the target volume. The offline volume copy relationship is between a source volume and a target volume.

Source volumes that are participating in an offline copy are available for read requests only while a volume copy has a status of In Progress or Pending. Write requests are allowed after the offline copy has completed. If the source volume has been formatted with a journaling file system, any attempt to issue a read request to the source volume might be rejected by the storage array controllers, and an error message might appear. The journaling file system driver issues a write request before it attempts to issue the read request. The controller rejects the write request, and the read request might not be issued due to the rejected write request. This condition might result in an error message appearing, which indicates that the source volume is write protected. To prevent this issue from occurring, do not attempt to access a source volume that is participating in an offline copy while the volume copy has a status of In Progress. Also, make sure that the Read-Only attribute for the target volume is disabled after the volume copy has completed to prevent error messages from appearing.

Online Copy

An online copy creates a point-in-time snapshot copy of a volume within a storage array, while still being able to write to the volume with the copy in progress. This function is achieved by creating a snapshot of the volume and using the snapshot as the actual source volume for the copy. The online volume copy relationship is between a snapshot volume and a target volume. The volume for which the point-in-time image is created is known as the base volume and must be a standard volume in the storage array.

A snapshot volume and a snapshot repository volume are created during the online copy operation. The snapshot volume is not an actual volume containing data; rather, it is a reference to the data that was contained on a volume at a specific time. For each snapshot that is taken, a snapshot repository volume is created to hold the copy-on-write data for the snapshot. The snapshot repository volume is used only to manage the snapshot image.

Before a data block on the source volume is modified, the contents of the block to be modified are copied to the snapshot repository volume for safekeeping. Because the snapshot repository volume stores copies of the original data in those data blocks, further changes to those data blocks write only to the source volume.



NOTE If the snapshot volume that is used as the copy source is active, the base volume performance is degraded due to copy-on-write operations. When the copy is complete, the snapshot is disabled, and the base volume performance is restored. Although the snapshot is disabled, the repository infrastructure and copy relationship remain intact.

The online copy function is enabled with the Snapshot Volume premium feature. To use the online copy function, you must enable the Snapshot Volume premium feature by purchasing a feature key file from your storage vendor.

Components of the Volume Copy Premium Feature

The Volume Copy premium feature includes these components:

Create Copy Wizard, which assists in creating a volume copy.

You can use the Create Copy Wizard to guide you through the following steps in creating a Volume Copy:

- Selecting a source volume from a list of available volumes and the type of copy you want to perform (offline or online)

- Selecting a target volume from a list of available volumes
- Allocating capacity for the snapshot repository volume for online copy types
- Setting the copy priority for the volume copy

When you have completed the wizard dialogs, the volume copy starts, and data is read from the source volume and written to the target volume. Operation in Progress icons appear on the source volume and the target volume while the volume copy has a status of In Progress or Pending.

Copy Manager, which monitors volume copies after they have been created.

After you create a volume copy with the Create Copy Wizard, you can monitor the volume copy through the Copy Manager. You can use the Copy Manager to perform the following actions:

- Monitor the progress of a volume copy
- Stop a volume copy
- Re-copy a volume copy
- Remove copy pairs
- Change target volume permissions
- Change copy priority

Keep these guidelines in mind when you create a volume copy.

| | |
|---|--|
| Failed Controller | You must manually change controller ownership to the alternate controller to allow the volume copy to complete under all of these conditions: <ul style="list-style-type: none"> ▪ The preferred controller of the source volume fails. ▪ The ownership transfer does not occur automatically in the failover. |
| Volume Failover for Online Copy Types | Ownership changes affect the base volume and all of its snapshots. The same controller should own the base volume, the snapshot volume, and the snapshot repository volume. The rules that apply to the base volume for host-driver-based or controller-based failover modes also apply to the associated snapshots and snapshot repository volumes. If a failover situation occurs, all related volumes change controller ownership as a group. |
| Volume Copy and Modification Operations for Offline Copy Types | For offline copy operations, if a modification operation is running on a source volume or a target volume, and the volume copy has a status of In Progress, Pending, or Failed, the volume copy does not take place. If a modification operation is running on a source volume or a target volume after a volume copy has been created, the modification operation must complete before the volume copy can start. If a volume copy has a status of In Progress, any modification operation does not take place. |
| Preferred Controller Ownership | During a volume copy, the same controller must own both the source volume and the target volume. If both volumes do not have the same preferred controller when the volume copy starts, the ownership of the target volume is automatically transferred to the preferred controller of the source volume. When the volume copy is completed or is stopped, |

| | |
|---|---|
| | ownership of the target volume is restored to its preferred controller. If ownership of the source volume is changed during the volume copy, ownership of the target volume is also changed. |
| Failed Volume Copy | <p>A volume copy can fail due to these conditions:</p> <ul style="list-style-type: none"> ▪ A read error from the source volume ▪ A write error to the target volume ▪ A failure in the storage array that affects the source volume or the target volume, such as a remote volume mirror role reversal <p>When the volume copy fails, a Needs Attention icon appears in the Array Management Window. While a volume copy has this status, the host has read-only access to the source volume. Read requests from and write requests to the target volume do not take place until the failure is corrected by using the Recovery Guru.</p> |
| Volume Copy Status | If eight volume copies with a status of In Progress exist, any subsequent volume copy will have a status of Pending, which remains until one of the eight volume copies completes. |
| Snapshot Volume | <p>A volume copy fails all snapshot volumes that are associated with the target volume, if any exist. If you select a base volume of a snapshot volume, you must disable all of the snapshot volumes that are associated with the base volume before you can select it as a target volume. Otherwise, the base volume cannot be used as a target volume.</p> <p>A volume copy overwrites data on the target volume and automatically makes the target volume read-only to hosts.</p> |
| Snapshot Failure | If a snapshot volume that is serving as an online copy fails, the volume copy relationship is still maintained between the snapshot volume and the target volume. If the snapshot failure occurs when the physical copy is in progress, the status of "Failed" is displayed in the Copy Manager. |
| Volume Consistency | When using the online volume copy operation, make sure that the source volume is in a consistent state. If the source volume is not consistent, the online volume copy is also inconsistent. An inconsistent volume might be unusable for its purpose, such as backup. |
| Copy Failure for Online Copy Types | A copy failure terminates the copy-on-write process for the snapshot volume. If a copy failure occurs due to a snapshot failure because of snapshot repository volume overflow, you can correct the failure by deleting the copy relationship and re-creating it. |

Restrictions on Volume Copy

These restrictions apply to the source volume, the target volume, and the storage array when performing volume copy operations.

For an offline volume copy, the source volume is available for read requests only while a volume copy has a status of In Progress or Pending. Write requests are allowed after the volume copy is completed.

- You can use a volume as a target volume in only *one* volume copy at a time.

- The maximum allowable number of volume copies per storage array depends on the number of target volumes that are available in your storage array.
- A storage array can have up to *eight* volume copies running at any given time.
- The capacity of the target volume must be equal to or greater than the capacity of the source volume.

For an offline volume copy, a source volume can be one of the following volumes:

- A standard volume
- A snapshot volume
- A snapshot base volume
- A remote volume mirror primary volume

For an online volume copy, a source volume can only be a standard volume.

- If the source volume is a primary volume, the capacity of the target volume must be equal to or greater than the usable capacity of the source volume.
- You cannot use the snapshot volume copy until after the online copy operation completes.
- You cannot use any of the Snapshot Volume options (**Disable**, **Re-create**, **Create Copy**, **Delete**, and **Rename**) or perform host mapping on a snapshot volume that was created using the online copy operation in the Create Copy Wizard.

A target volume can be one of these volumes:

- A standard volume
- A base volume of a disabled snapshot volume or a failed snapshot volume
- A remote volume mirror primary volume



NOTE If you choose a base volume of a snapshot volume as your target volume, you must disable all snapshot volumes that are associated with the base volume before you can select it as a target volume. Otherwise, you cannot use the base volume as a target volume.

Volumes that have these statuses cannot be used as a source volume or a target volume:

- A volume that is reserved by the host cannot be selected as a source volume or a target volume
- A volume that is in a modification operation
- A volume that is the source volume or a target volume in another volume copy operation with a status of Failed, In Progress, or Pending
- A volume with a status of Failed
- A volume with a status of Degraded

For detailed information about this premium feature, refer to the online help topics in the Array Management Window.

SafeStore Drive Security and SafeStore Enterprise Key Manager

SafeStore Drive Security is a premium feature that prevents unauthorized access to the data on a Full Disk Encryption (FDE) drive that is physically removed from the storage array. Controllers in the storage array have a security key. Secure drives provide access to data only through a controller that has the correct security key. SafeStore Drive Security is a premium feature of the storage management software and must be enabled either by you or your storage vendor.

The SafeStore Drive Security premium feature requires security capable FDE drives. A security capable FDE drive encrypts data during writes and decrypts data during reads. Each security capable FDE drive has a unique drive encryption key.

When you create a secure volume group from security capable drives, the drives in that volume group become security enabled. When a security capable drive has been security enabled, the drive requires the correct security key from a controller to read or write the data. All of the drives and controllers in a storage array share the same security key. The shared security key provides read access and write access to the drives, while the drive encryption key on each drive is used to encrypt the data. A security capable drive works like any other drive until it is security enabled.

Whenever the power is turned off and turned on again, all of the security enabled drives change to a *security locked* state. In this state, the data is inaccessible until the correct security key is provided by a controller.

The SafeStore Enterprise Key Manager premium feature integrates external key management products.

You can view the SafeStore Drive Security status of any drive in the storage array. The status information reports whether the drive is in one of these states:

- Security Capable
- Secure – Security enabled or security disabled
- Read/Write Accessible – Security locked or security unlocked

You can view the SafeStore Drive Security status of any volume group in the storage array. The status information reports whether the storage array is in one of these states:

- Security Capable
- Secure

This table interprets the security properties status of a volume group.

Volume Group Security Properties

| | Security Capable – yes | Security Capable – no |
|---------------------|--|---|
| Secure – yes | The volume group is composed of all FDE drives and is in a Secure state. | Not applicable. Only FDE drives can be in a Secure state. |
| Secure – no | The volume group is composed of all FDE drives and is in a Non-Secure state. | The volume group is not entirely composed of FDE drives. |

When the SafeStore Drive Security premium feature has been enabled, the **Drive Security** menu appears in the **Storage Array** menu. The **Drive Security** menu has these options:

- **Security Key Management**

- **Create Security Key**
- **Change Security Key**
- **Save Security Key**
- **Validate Security Key**
- **Import Security Key File**

The **Security Key Management** option lets you specify how to manage the security key. By default, the security key is managed locally by the controllers. The controllers generate the security key and save the security key in the nonvolatile static random access memory (NVS RAM) of the controllers. You can use the SafeStore Enterprise Key Manager to have an external key management server generate the security key.



NOTE If you have not created a security key for the storage array, the **Create Security Key** option is active. If you have created a security key for the storage array, the **Create Security Key** option is inactive with a check mark to the left. The **Change Security Key** option, the **Save Security Key** option, and the **Validate Security Key** option are now active.

The **Import Security Key File** option is active if there are any security locked drives in the storage array.

When the SafeStore Drive Security premium feature has been enabled, the **Secure Drives** option appears in the **Volume Group** menu. The **Secure Drives** option is active if these conditions are true:

- The selected storage array is not security enabled but is comprised entirely of security capable drives.
- The storage array does not contain any snapshot base volumes or snapshot repository volumes.
- The volume group is in an Optimal state.
- A security key is set up for the storage array.

The **Secure Drives** option is inactive if the conditions are not true.

The **Secure Drives** option is inactive with a check mark to the left if the volume group is already security enabled.

You can erase security enabled drives so that you can reuse the drives in another volume group, in another storage array, or if you are decommissioning the drives. When you erase security enabled drives, you make sure that the data cannot be read. When all of the drives that you have selected in the Physical pane are security enabled, and none of the selected drives are part of a volume group, the **Secure Erase** option appears in the **Drive** menu.

The storage array password protects a storage array from potentially destructive operations by unauthorized users. The storage array password is independent from the SafeStore Drive Security premium feature and should not be confused with the pass phrase that is used to protect copies of a security key. However, as a best practice, set a storage array password before you create, change, or save a security key or unlock secure drives.

Using SafeStore Enterprise Key Manager

The SafeStore Enterprise Key Manager premium feature lets you specify how to manage the security key. You can choose to manage the security key locally by the controllers or externally by an external key management server. By default, the security key is managed locally by the controllers. The controllers generate the security key and save the security key in the nonvolatile static random access memory

(NVS RAM) of the controllers. You can also use the SafeStore Enterprise Key Manager to have an external key management server generate the security key. To change the management method, select **Storage Array > SafeStore Drive Security > Security Key Management**.



ATTENTION Changing the method of managing the security key from local to external requires creating and saving a new security key. This action makes any previously saved security key for the storage array invalid.



NOTE External key management must be enabled for both the source storage array, from which the key is saved, and any target storage array that imports the key. The key management server used by the source storage array must be accessible to the target storage array.

A copy of the security key must be kept on some other storage medium for backup, in case of controller failure or for transfer to another storage array. A pass phrase that you provide is used to encrypt and decrypt the security key for storage on other media. The storage array password protects a storage array from potentially destructive operations by unauthorized users. The storage array password is independent from the SafeStore Drive Security feature and should not be confused with the pass phrase that is used to protect copies of a security key. However, it is good practice to set a storage array password before you change a security key.

Creating a Security Key

Drives with the full disk encryption technology are *security capable*. This capability enables the controller to apply security to every security capable drive in the storage array. The controller firmware creates a key and activates the drive's security function, which encrypts data as it enters, and decrypts data as it is read. Without the key, the data written on a drive is inaccessible and unreadable. A security enabled drive can also be configured to require a password, PIN, or certificate; however, this function is separate from the encryption and decryption processes.

The storage array password protects a storage array from potentially destructive operations by unauthorized users. The storage array password is independent from the SafeStore Drive Security premium feature and should not be confused with the pass phrase that is used to protect copies of a SafeStore Drive Security key. However, it is good practice to set a storage array password before you create a SafeStore Drive Security key.

After the controller creates the key, the storage array moves from a state of *security capable* to a state of *security enabled*. The security enabled condition requires the drives to obtain a key to access their media. As an added security measure, when power is applied to the storage array, the drives are all placed in a *security locked* state. They are only unlocked during drive initialization with the controller's key. The *security unlocked* state allows the drives to be accessible so that read and write activities can be performed.

Changing a Security Key

A new security key is generated by the controller firmware for these reasons:

- You need to change the security key.
- You need to change the method of managing the security key from local to external.



ATTENTION Changing the method of managing the security key makes any previously saved security keys invalid.

The new security key is stored in the nonvolatile static random access memory (NVS RAM) of the controllers. The new key replaces the previous key. You cannot see the security key directly. A copy of the security key must be kept on some other storage medium for backup, in case of controller failure or for transfer to another storage array. A pass phrase that you provide is used to encrypt and decrypt the security key for storage on other media.

The storage array password protects a storage array from potentially destructive operations by unauthorized users. The storage array password is independent from the SafeStore Drive Security feature and should not be confused with the pass phrase that is used to protect copies of a SafeStore Drive Security key. However, it is good practice to set a storage array password before you change a SafeStore Drive Security key.

Saving a Security Key

You save an externally storable copy of the security key when the security key is first created and each time it is changed. You can create additional storable copies at any time. To save a new copy of the security key, you must provide a pass phrase. The pass phrase that you choose does not need to match the pass phrase that was used when the security key was created or last changed. The pass phrase is applied to the particular copy of the security key that you are saving.

Keep these guidelines in mind when you create a pass phrase:

- The pass phrase must be between eight and 32 characters long.
- The pass phrase must contain at least one uppercase letter.
- The pass phrase must contain at least one lowercase letter.
- The pass phrase must contain at least one number.
- The pass phrase must contain at least one non-alphanumeric character, for example, <, >, @, or +.

The characters you enter are not readable in the **Pass phrase** text box.

The storage array password protects a storage array from potentially destructive operations by unauthorized users. The storage array password is independent from the SafeStore Drive Security feature and should not be confused with the pass phrase that is used to protect copies of a security key. However, it is good practice to set a storage array password before you save a security key.

Unlocking Secure Drives

You can export a security enabled volume group to move the associated drives to a different storage array. After you install those drives in the new storage array, you must unlock the drives before data can be read from or written to the drives. To unlock the drives, you must supply the security key from the original storage array. The security key on the new storage array will be different and will not be able to unlock the drives.

You must supply the security key from a security key file that was saved on the original storage array. You must provide the pass phrase that was used to encrypt the security key file to extract the security key from this file.

The storage array password protects a storage array from potentially destructive operations by unauthorized users. The storage array password is independent from the SafeStore Drive Security feature and should not be confused with the pass phrase that is used to protect copies of a security key. However, it is good practice to set a storage array password before you unlock secure drives.

Validating the Security Key

You validate a file in which a security key is stored through the **Validate Security Key** dialog. To transfer, archive, or back up the security key, the controller firmware encrypts (or wraps) the security key and stores it in a file. You must provide a pass phrase and identify the corresponding file to decrypt the file and recover the security key.



NOTE You can also install the security key from an external key management server. External key management must be enabled for both the source storage array and the target storage array. The key management server used by the source storage array must be accessible by the target storage array.

Data can be read from a security enabled drive only if a controller in the storage array provides the correct security key. If you move security enabled drives from one storage array to another, you must also import the appropriate security key to the new storage array. Otherwise, the data on the security enabled drives that were moved is inaccessible.



IMPORTANT After 20 consecutive unsuccessful attempts to validate a security key, you might be blocked from making further attempts at validation. The Recovery Guru guides you to reset the limit and make additional attempts. Data on the drives is temporarily inaccessible during the reset procedure.

SafeStore Data Assurance Premium Feature

The SafeStore Data Assurance (DA) premium feature checks for and corrects errors that might occur as data is moved within the controller, such as from cache to the drive. This checking leads to correction of write errors and increases data integrity across the entire storage system. DA is implemented using the SCSI direct-access block-device protection information model. DA creates error-checking information, such as a cyclic redundancy check (CRC) and appends that information to each block of data. Any errors that might occur when a block of data is transmitted or stored is then detected and corrected by checking the data with its error-checking information.

Only certain configurations of hardware, including DA-capable drives, controllers, and host interface cards (HICs), support the SafeStore Data Assurance premium feature. When you install the DA premium feature on a storage array, SANtricity ES Storage Manager provides options to use DA with certain operations. For example, you can create a volume group that includes DA-capable drives and then create a volume within that volume group that is DA enabled. Other operations that use a DA-enabled volume have options to support the DA premium feature.

For detailed information about this premium feature, refer to the online help topics in the Array Management Window.

Solid State Disks

Some controllers and drive trays now support Solid State Disks (SSDs). SSDs are data storage devices that use solid state memory (flash) to store data persistently. An SSD emulates a conventional hard drive, thus easily replacing it in any application. SSDs are available with the same interfaces used by hard drives.

The advantages of SSDs over hard drives are:

- Faster start up (no spin up)
- Faster access to data (no rotational latency or seek time)
- Higher I/O operations per second (IOPS)
- Higher reliability with fewer moving parts

- Lower power usage
- Less heat produced and less cooling required

SSD support is a premium feature of the storage management software that must be enabled by either you or your storage vendor.

Identifying SSDs

You can identify SSDs in the storage management software either by the label “SSD” or this icon. 

In addition to drive firmware, SSDs have field-programmable gate array (FPGA) code that might be updated periodically. An FPGA version is listed in the drive properties, which you can see in the storage management software by selecting a drive on the **Physical** tab. Also, SSDs do not have a speed listed in the drive properties like hard drives do.

Creating Volume Groups

All of the drives in a volume group must have the same media type (hard drive or SSD) and the same interface type. Hot spare drives must also be of the same drive type as the drives they are protecting.

Wear Life

A flash-based SSD has a limited wear life before individual memory locations can no longer reliably persist data. The drive continuously monitors itself and reports its wear life status to the controller. Two mechanisms exist to alert you that an SSD is nearing the end of its useful life: average erase count and spare blocks remaining. You can find these two pieces of information in the drive properties, which you can see in the storage management software by selecting a drive on the **Physical** tab.

The average erase count is reported as a percentage of the rated lifetime. When the average erase count reaches 80 percent, an event is logged to the Major Event Log (MEL). At this time, you should schedule the replacement of the SSD. When the average erase count reaches 90 percent, a Needs Attention condition occurs. At this time, you should replace the SSD as soon as possible.

The spare blocks remaining are reported as a percentage of the total blocks. When the number of spare blocks remaining falls below 20 percent, an event is logged to the MEL. At this time, you should schedule the replacement of the SSD. When the number of spare blocks remaining falls below 10 percent, a Needs Attention condition occurs. At this time, you should replace the SSD as soon as possible.

Write Caching

Write caching will always be enabled for SSDs. Write caching improves performance and extends the life of the SSD.

Background Media Scans

Background media scans are not necessary for SSDs because of the high reliability of SSDs.

Heterogeneous Hosts

Heterogeneous hosts are hosts with different operating systems that share access to the same storage array. When you change a host type, you are changing the operating system (OS) for the host adapter's host port.

To specify different operating systems for attached hosts, you must specify the appropriate host type when you define the host ports for each host. Host types can be completely different operating systems, or can be variants of the same operating system. By specifying a host type, you define how the controllers in the storage array will work with the particular operating system on the hosts that are connected to it.

Password Protection



IMPORTANT Running operations that alter the configuration of your storage array can cause serious damage, including data loss. Configuring a password for each storage array that you manage prevents unauthorized access to destructive commands.

For added security, you can configure each storage array with a password to protect it from unauthorized access. A password protects any options that the controller firmware deems destructive. These options include any functions that change the state of the storage array, such as creating a volume or modifying the cache setting.



IMPORTANT If you forget the password, contact your Customer and Technical Support representative.

After the password has been set on the storage array, you are prompted for that password the first time you attempt an operation in the Array Management Window that can change the state of the storage array, such as modifying the cache settings. You are asked for the password only once during a single management session.

For storage arrays with a password and alert notifications configured, any attempts to access the storage array without the correct password are reported.

The storage management software provides other security features to protect data, including generation numbering to prevent replay attacks and hashing and encryption to guard against client spoofing and snooping.

Persistent Reservations Management



ATTENTION Customer and Technical Support representative supervision required – Do not perform this procedure unless you are supervised by your Customer and Technical Support representative.

Persistent reservation management lets you view and clear volume reservations and associated registrations. Persistent reservations are configured and managed through the cluster server software and prevent other hosts from accessing particular volumes.

Unlike other types of reservations, a persistent reservation performs these functions:

- Reserves access across multiple host ports
- Provides various levels of access control
- Offers the ability to query the storage array about registered ports and reservations
- Optionally, provides for persistence of reservations in the event of a storage array power loss

The storage management software lets you manage persistent reservations by performing these tasks:

- Viewing registration and reservation information for all of the volumes in the storage array
- Saving detailed information on volume reservations and registrations

- Clearing all registrations and reservations for a single volume or for all of the volumes in the storage array.

HotScale Technology

HotScale™ technology lets you configure, reconfigure, add, or relocate storage array capacity without interrupting user access to data.

Port bypass technology automatically opens ports and closes ports when drive trays are added to or removed from your storage array. Fibre Channel loops stay intact so that system integrity is maintained throughout the process of adding and reconfiguring your storage array.

For more information about using the HotScale technology, contact your Customer and Technical Support representative.

Maintaining and Monitoring Storage Arrays

The topics in this section describe the methods for maintaining storage arrays, including troubleshooting storage array problems, recovering from a storage array problem using the Recovery Guru, and configuring alert notifications using the Event Monitor.

For additional conceptual information and detailed procedures for the options described in this section, refer to the Learn About Monitoring Storage Arrays online help topic in the Enterprise Management Window.

Storage Array Health



IMPORTANT To receive notification of events for the storage arrays, you must configure alert notifications in the Enterprise Management Window, and the Event Monitor must be running.

The Enterprise Management Window summarizes the conditions of all of the known storage arrays being managed. Appropriate status indicators appear in the Tree view on the **Devices** tab, the Table view on the **Devices** tab, and the Health Summary Status area in the lower-left corner of the window. To show the status bar, select **View > Status Bar**.

Background Media Scan

A background media scan is a background process that is performed by the controllers to provide error detection on the drive media. A background media scan can find media errors before they disrupt normal drive reads and writes. The background media scan process scans all volume data to make sure that it can be accessed. The errors are reported to the Event Log.

A background media scan runs on all volumes in the storage array for which it has been enabled. You must enable the media scan for the entire storage array, and for individual volumes. If you enable a redundancy check, the background media scan also scans the redundancy data on a RAID Level 1 volume, a RAID Level 3 volume, a RAID Level 5 volume, or a RAID Level 6 volume.

Event Monitor

The Event Monitor runs continuously in the background, monitoring activity on a storage array and checking for problems. Examples of problems include impending drive failures or failed controllers. If the Event Monitor detects any problems, it can notify a remote system by using email notifications, Simple Network Management Protocol (SNMP) trap messages, or both, if the Enterprise Management Window is not running.

The Event Monitor is a client that is bundled with the client software. Install the Event Monitor on a computer that runs 24 hours a day. The client and the Event Monitor are installed on a storage management station or a host that is connected to the storage arrays. Even if you choose not to install the Event Monitor, you can still configure alert notifications on the computer on which the client software is installed.

The following figure shows how the Event Monitor and the Enterprise Management Window client software send alerts to a remote system. The storage management station contains a file with the name of the storage array being monitored and the address to which alerts will be sent. The alerts and errors that occur on the storage array are continuously being monitored by the client software and the Event Monitor. The Event Monitor continues to monitor the client, even after the client software package is shut down. When an event is detected, a notification is sent to the remote system.

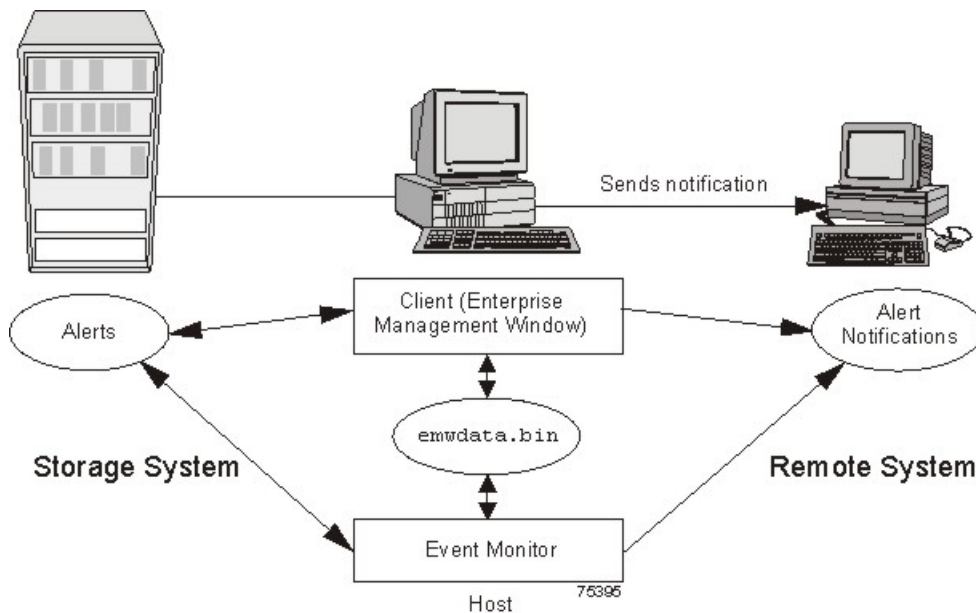

Because the Event Monitor and the Enterprise Management Window share the information to send alert messages, the Enterprise Management Window has some visual cues to assist in the installation and synchronization of the Event Monitor.

Using the Event Monitor involves these three key steps:

1. Installing the client software
2. Setting up the alert destinations for the storage arrays that you want to monitor from the Enterprise Management Window
3. Synchronizing the Enterprise Management Window and the Event Monitor

Alert Notifications

You can configure alert notifications by using the storage management software.

Configuring Alert Notifications

You must configure alert notification settings to receive email notifications or SNMP notifications when an event occurs in a storage array. The notification summarizes the event and details about the affected storage array, including these items:

- The name of the affected storage array
- The host IP address (for an in-band managed storage array)
- The host name and ID (shown as out-of-band if the storage array is managed through the Ethernet connection of each controller)
- The event error type related to an Event Log entry
- The date and the time when the event occurred
- A brief description of the event



IMPORTANT To set up alert notifications using SNMP traps, you must copy and compile a management information base (MIB) file on the designated network management station.

Three key steps are involved in configuring alert notifications:

1. Select a node in the Enterprise Management Window that shows alert notifications for the storage arrays that you want to monitor. You can select every storage array being managed, every storage array attached to and managed through a particular host, and individual storage arrays.
2. Configure email destinations, if desired.
3. Configure SNMP trap destinations, if desired. The SNMP trap destination is the IP address or the host name of a station running an SNMP service, such as a network management station.

Customer Support Alert Notifications

If an event occurs in a storage array, the Enterprise Management Window contains options to configure the system to send email notifications to a specified customer support group. After the alert notification option is configured, the email alert notification summarizes the event, provides details about the affected storage array, and provides customer contact information. For more information about setting up this file, contact your Customer and Technical Support representative.

Performance Monitor

The Performance Monitor provides visibility into performance activity across your monitored storage devices. You can use the Performance Monitor to perform these tasks:

- View in real time the values of the data collected for a monitored device. This capability helps you to determine if the device is experiencing any problems.
- See a historical view of a monitored device to identify when a problem started or what caused a problem.
- Specify various reporting attributes, such as time increments and filtering criteria, to examine performance trends and to pinpoint the cause of availability and performance issues.
- Display data in tabular format (actual values of the collected metrics) or graphical format (primarily as line-graphs), or export the data to a file.

About Metrics

Metrics are measurements of the data that the Performance Monitor collects from the storage devices that you monitor. Metrics help to pinpoint problems and define their cause. Metrics define the types of data that you collect as well as the type of data source from which you collect the data.

Performance Metric Data

You can collect the following metric data:

- **Total I/Os** – Total I/Os performed by this device since the beginning of the polling session.
- **Read Percentage** – The percentage of total I/Os that are read operations for this device. Write percentage can be calculated as 100 minus this value.
- **Cache Hit Percentage** – The percentage of total I/Os that are processed with data from the cache rather than requiring a read from drive.
- **I/O per second** – The number of I/O requests serviced per second during the current polling interval (also called an I/O request rate).

- **KBs or MBs per second** – The transfer rate during the current polling interval. The transfer rate is the amount of data in kilobytes (Table view) or megabytes (Graphical view) that can be moved through the I/O data connection in a second (also called throughput).



NOTE A kilobyte is equal to 1024 bytes, and a megabyte is equal to 1024 x 1024 bytes (1,048,576 bytes).

Metric Sources

Metrics define how the Performance Monitor collects data from supported data sources called metric sources. Metric sources are the aspects of a storage array or a controller that provide data. You can configure the Performance Monitor to report data from the following metric sources:

- Volume
- Volume group
- Controller
- Storage array

You can use the data to create reports, and make tuning decisions based on the data values. If a value is outside of the desired range or is in an undesired state, you can take action to correct the problem.



NOTE The Performance Monitor reports volume metrics and volume group metrics at the storage array level, regardless of volume controller ownership changes that might occur during monitoring.

Viewing Performance Data

The Performance Monitor provides both real-time analysis and historical context of performance metrics. The metrics are available in either of two views:

- **Table view** – In the Table view, the data is displayed in a tabular format. The actual numeric values of the collected metrics are displayed in a data table.
- **Graphical view** – In the Graphical view, the data is presented with a single x-axis and a single y-axis. The x-axis represents the time for which you selected to view performance data. The y-axis represents the metric you selected to view for a particular metric source.

Performance Tuning

The Performance Monitor provides you with data about devices. You use this data to make storage array tuning decisions, as described in the following table. When performance issues are encountered, tuning is required to alleviate the issues.

| Performance Metric Data | Implications for Performance Tuning |
|--------------------------------|--|
| Total I/Os | This data is useful for monitoring the I/O activity of a specific controller and a specific volume, which can help identify possible high-traffic I/O areas. If the I/O rate is slow on a volume, try increasing the volume group size by selecting Volume Group > Add Free Capacity (Drives) . |

| Performance Metric Data | Implications for Performance Tuning |
|-------------------------|--|
| | <p>You might notice a disparity in the total I/Os (workload) of controllers. For example, the workload of one controller is heavy or is increasing over time while that of the other controller is lighter or more stable. In this case, you might want to change the controller ownership of one or more volumes to the controller with the lighter workload. Use the volume total I/O statistics to determine which volumes to move.</p> <p>You might want to monitor the workload across the storage array. Look at the Total I/Os column of the Storage Array Totals row in the Performance Monitor window. If the workload continues to increase over time while application performance decreases, you might need to add additional storage arrays. By adding storage arrays to your enterprise, you can continue to meet application needs at an acceptable performance level.</p> |
| Read Percentage | <p>Use the Read Percentage for a volume to determine actual application behavior. If a low percentage of read activity exists relative to write activity, you might want to change the RAID level of a volume group from RAID Level 5 to RAID Level 1 to obtain faster performance.</p> |
| Cache Hit Percentage | <p>A higher cache hit percentage is desirable for optimal application performance. A positive correlation exists between the cache hit percentage and the I/O rates.</p> <p>The cache hit percentage of all of the volumes might be low or trending downward. This trend might indicate inherent randomness in access patterns. In addition, at the storage array level or the controller level, this trend might indicate the need to install more controller cache memory if you do not have the maximum amount of memory installed.</p> <p>If an individual volume is experiencing a low cache hit percentage, consider enabling dynamic cache read prefetch for that volume. Dynamic cache read prefetch can increase the cache hit percentage for a sequential I/O workload.</p> |
| KB/s or MB/s | <p>The transfer rates of the controller are determined by the application I/O size and the I/O rate. Generally, small application I/O requests result in a lower transfer rate but provide a faster I/O rate and shorter response time. With larger application I/O requests, higher throughput rates are possible. Understanding your typical application I/O patterns can help you determine the maximum I/O transfer rates for a specific storage array.</p> |
| IOPS | <p>Factors that affect input/output operations per second (IOPS) include these items:</p> <ul style="list-style-type: none"> ▪ Access pattern (random or sequential) ▪ I/O size ▪ RAID level ▪ Segment size ▪ The number of drives in the volume groups or storage array <p>The higher the cache hit rate, the higher I/O rates will be.</p> <p>You can see performance improvements caused by changing the segment size in the IOPS statistics for a volume. Experiment to determine the optimal segment size, or use the file system size or database block size.</p> <p>Higher write I/O rates are experienced with write caching enabled compared to disabled. In deciding whether to enable write caching for an individual volume, look at the current IOPS and the maximum IOPS. You should see higher rates for sequential I/O patterns than for random I/O patterns. Regardless of your I/O pattern, enable write caching to maximize the I/O rate and to shorten the application response time.</p> |

For detailed information about the Performance Monitor, refer to the online help topics in the Array Management Window.

Viewing Operations in Progress

The **Operations in Progress** dialog displays all of the long-running operations that are currently running in the storage array. From this dialog, you cannot interact with the operations. You can only view their progress.

The **Operations in Progress** dialog remains open until you close it or until you close the Array Management Window (AMW). You can do other tasks in the AMW while the **Operations in Progress** dialog is open.

You can view the progress for the following long-running operations:

- Dynamic Capacity Expansion (DCE) – Adding capacity to a volume group
- Dynamic RAID Migration (DRM) – Changing the RAID level of a volume group
- Checking the data redundancy of a volume group
- Defragmenting a volume group
- Initializing a volume
- Dynamic Volume Expansion (DVE) – Adding capacity to a volume
- Dynamic Segment Size (DSS) – Changing the segment size of a volume
- Reconstruction – Reconstructing data from parity because of unreadable sectors or a failed drive
- Copyback – Copying data from a hot spare drive to a new replacement drive
- Volume copy
- Synchronizing a remote mirror

For detailed information about this feature, refer to the online help topics in the Array Management Window.

Retrieving Trace Buffers



NOTE Use this option only under the guidance of your Customer and Technical Support representative.

You can save trace information to a compressed file. The firmware uses the trace buffers to record processing, including exception conditions, that might be useful for debugging. Trace information is stored in the current buffer. You have the option to move the trace information to the flushed buffer after you retrieve the information. You can retrieve trace buffers without interrupting the operation of the storage array and with minimal effect on performance.

A zip-compressed archive file is stored at the location you specify on the host. The archive contains trace files from one or both of the controllers in the storage array along with a descriptor file named `trace_description.xml`. Each trace file includes a header that identifies the file format to the analysis software used by the Customer and Technical Support representative. The descriptor file has the following information:

- The World Wide Identifier (WWID) for the storage array.
- The serial number of each controller.
- A time stamp.
- The version number for the controller firmware.
- The version number for the management application programming interface (API).

- The model ID for the controller board.
- The collection status (success or failure) for each controller. If the status is Failed, the reason for failure is noted, and there is no trace file for the failed controller.

For detailed information about this feature, refer to the online help topics in the Array Management Window.

Upgrading the Controller Firmware

You can upgrade the firmware of the controllers in the storage array by using the storage management software.

In the process of upgrading the firmware, the firmware file is downloaded from the host to the controller. After downloading the firmware file, you can upgrade the controllers in the storage array to the new firmware immediately. Optionally, you can download the firmware file to the controller and upgrade the firmware later at a more convenient time.

The process of upgrading the firmware after downloading the firmware file is known as *activation*. During activation, the existing firmware file in the memory of the controller is replaced with the new firmware file.

The firmware upgrade process requires that the controllers have enough free memory space in which the firmware file resides until activation.

A version number exists for each firmware file. For example, 06.60.08.00 is a version number for a firmware file. The first two digits indicate the major revision of the firmware file. The remaining digits indicate the minor revision of the firmware file. You can view the version number of a firmware file in the **Upgrade Controller Firmware** window and the **Download Firmware** dialog. For more information, refer to the Downloading the Firmware online help topic in the Enterprise Management Window.

The process of upgrading the firmware can be either a major upgrade or a minor upgrade depending on the version of the firmware. For example, the process of upgrading the firmware is major if the version of the current firmware is 06.60.08.00, and you want to upgrade the firmware to version 07.36.12.00. In this example, the first two digits of the version numbers are different and indicate a major upgrade. In a minor upgrade, the first two digits of the version numbers are the same. For example, the process of upgrading the firmware is minor if the version of the current firmware is 06.60.08.00, and you want to upgrade the firmware to version 06.60.18.00 or any other minor revision of the firmware.

You can use the Enterprise Management Window to perform both major upgrades and minor upgrades. You can use the Array Management Window to perform minor upgrades only.

The storage management software checks for existing conditions in the storage array before upgrading the firmware. Any of these conditions in the storage array can prevent the firmware upgrade:

- An unsupported controller type or controllers of different types that are in the storage array that cannot be upgraded
- One or more failed drives
- One or more hot spare drives that are in use
- One or more volume groups that are incomplete
- Operations, such as defragmenting a volume group, downloading of drive firmware, and others, that are in progress
- Missing volumes that are in the storage array
- Controllers that have a status other than Optimal

- The storage partitioning database is corrupt
- A data validation error occurred in the storage array
- The storage array has a Needs Attention status
- The storage array is unresponsive, and the storage management software cannot communicate with the storage array
- The Event Log entries are not cleared

You can correct some of these conditions by using the Array Management Window. However, for some of the conditions, you might need to contact your Customer and Technical Support representative. The storage management software saves the information about the firmware upgrade process in log files. This action helps the Customer and Technical Support representative to understand the conditions that prevented the firmware upgrade.

You can view the status of a storage array in the Status area of the **Upgrade Controller Firmware** window. Based on the status, you can select one or more storage arrays for which you want to upgrade the firmware.

You also can use the command line interface (CLI) to download and activate firmware to several storage arrays. For more information, refer to the About the Command Line Interface online help topic in the Enterprise Management Window.

Monitoring the Status of the Download









Monitor the progress and completion status of the firmware and NVSRAM download to the controllers to make sure that errors did not occur. After the **Confirm Download** dialog is dismissed, the file is transferred to the storage array. Each controller is sent the new file one at a time. If the file transfer to the first controller succeeds, then the file is transferred to the second controller. The status of the file transfer and the update to each participating controller appear in the **Upgrade Controller Firmware** window.



NOTE When the firmware download successfully completes, a dialog might appear stating that the current version of the Array Management Window (AMW) is not compatible with the new firmware just downloaded. If you see this message, dismiss the AMW for the storage array, and open it again after selecting the storage array in the Enterprise Management Window (EMW) and selecting **Tools > Manage Storage Array**. This action launches a new version of the AMW that is compatible with the new firmware.

The progress and status of optimal controllers that are participating in the download appear. Controllers with statuses other than Optimal are not represented.

| Status | Description |
|---|---|
| During Firmware or NVSRAM Download | |
| Progress bar | Transferring the firmware or the NVSRAM and the completed percentage |
| During Firmware or NVSRAM Activation | |
| Progress bar | Activating the firmware or the NVSRAM and the completed percentage of firmware activation |
| After Download and Results | |
| Firmware Pending | The storage array has pending firmware that is ready for activation. |

| Status | Description |
|---|---|
|  | |
| Refreshing  | The storage array status is refreshing. |
| Error  | An error occurred during the operation. |
| Unresponsive  | The storage array cannot be contacted. |
| Not-upgradeable  | The storage array cannot be upgraded for one or more reasons. For more information, refer to the Upgrading the Controller Firmware online help topic. |
| Health Check Passed  | No problems were detected, and you can upgrade the storage array. |
| Upgradeable: Needs Attention  | One or more problems were detected, but you can still upgrade the storage array. |
| Firmware Upgraded  | The firmware is successfully upgraded in the storage array. |

During firmware downloads, the storage management software periodically polls the controller to see if the download has completed successfully. Sometimes, controller problems occur that keep the download from occurring. This table shows the results of firmware downloads if a controller is failed.

| Task | Result |
|--|--|
| You download new firmware to a storage array. A controller in the storage array fails, and you replace the failed controller with a new one. | After the new controller is installed, the storage array detects the controller replacement and synchronizes the firmware on both controllers. |
| You download new firmware to a storage array. A controller in the storage array fails, but you place the controller back online (assuming the problem was with something other than the controller). | The firmware synchronization does <i>not</i> occur. |

Problem Notification

 **IMPORTANT** To receive notification of events for the storage arrays, the Enterprise Management Window (EMW) or the Event Monitor must be running. In addition, you must have configured the alert notifications in the Enterprise Management Window.

Typically, storage array problems are indicated by using these status notifications:

- A Needs Attention status icon appears in several locations:
 - In the Status bar of the EMW
 - In the Tree view and the Table view on the **Devices** tab of the EMW
 - In the title bar of the Array Management Window (AMW)
 - In the storage array name and status area above the tabs in the AMW
- On the **Summary** tab, the **Logical** tab, and the **Physical** tab in the AMW

Event Log Viewer

The Event Log is a detailed record of events that occur in the storage array. You can use the Event Log as a supplementary diagnostic tool to the Recovery Guru for tracing storage array events. Always refer to the Recovery Guru first when you attempt to recover from component failures in the storage array.

The Event Log is stored in reserved areas on the disks in the storage array.

You can perform these actions in the **Event Log** window:

- View and filter the events that are displayed in the Event Log.
- Update the display to retrieve any new events.
- View detailed information about a selected event.
- Save selected Event Log data to a file.
- Clear the events in the Event Log.

The Event Log displays three levels of events: Critical, Informational, and Warning. To configure the destination addresses for delivery of email and SNMP trap messages that contain event details affecting managed storage arrays, select **Edit > Configure Alerts** in the Enterprise Management Window. For more information about SMTP notification, refer to the online help topics in the Enterprise Management Window.

Viewing the Event Log

From the Array Management Window (AMW), select **Advanced > Troubleshooting > View Event Log**.

Several minutes might elapse for an event to be logged and to become visible in the **Event Log** window.

Storage Array Problem Recovery

When you see a storage array **Needs Attention** icon or link, launch the Recovery Guru. The Recovery Guru is a component of the Array Management Window that diagnoses the problem and provides the appropriate procedure to use for troubleshooting.

Recovery Guru

The **Recovery Guru** window is divided into three panes:

- **Summary** - This pane lists storage array problems.
- **Details** - This pane shows information about the selected problem in the Summary pane.
- **Recovery Procedure** - This pane lists the appropriate steps to resolve the selected problem in the Summary pane.

For detailed information about the Recovery Guru, refer to the online help topics in the Array Management Window.

Glossary

A

Auto-Volume Transfer (AVT)

A feature of the controller firmware that helps to manage each volume in a storage array. When used with a multi-path driver, AVT helps to make sure that an I/O data path always is available for the volumes in the storage array.

C

configured capacity

Space on drives in a storage array that has been designated for use in a volume group.

controller

A circuit board and firmware that is located within a controller tray or a controller-drive tray. A controller manages the input/output (I/O) between the host system and data volumes.

copyback

The process of copying data from a hot spare drive to a replacement drive. When a failed drive has been physically replaced, a copyback operation automatically occurs from the hot spare drive to the replacement drive.

D

Default Group

A standard node to which all host groups, hosts, and host ports that do not have any specific mappings are assigned. The standard node shares access to any volumes that were automatically assigned default logical unit numbers (LUNs) by the controller firmware during volume creation.

duplex

A disk array system with two active controllers handling host input/output (I/O) requests, referred to as dual-active controllers.

Dynamic RAID-Level Migration (DRM)

A modification operation that changes the Redundant Array of Independent Disks (RAID) level on a selected volume group. During the entire modification process, the user can access data on volume groups, volumes, and drives in the storage management software. The user cannot cancel this operation after it starts.

Dynamic Volume Expansion (DVE)

A modification operation in the storage management software that increases the capacity of a standard volume or a snapshot repository volume. The operation uses the free capacity available on the volume group of the standard volume or the snapshot repository volume. This operation is considered to be dynamic because the user has the ability to continually access data on volume groups, volumes, and drives throughout the entire operation.

F**Fibre Channel (FC)**

A high-speed, serial, storage and networking interface that offers higher performance and greater capacity and cabling distance. FC offers increased flexibility and scalability for system configurations and simplified cabling. FC is a host interface that is a channel-network hybrid using an active, intelligent interconnection scheme (topology) to connect devices over a serial bus. The storage management software uses this connection between the host (where it is installed) and each controller in the storage array to communicate with the controllers.

firmware

Low-level program code that is installed into programmable read-only memory (PROM), where it becomes a permanent part of a computing device. The firmware contains the programming needed for boot and to implement storage management tasks.

Free Capacity node

A contiguous region of unassigned capacity on a defined volume group. The user assigns free capacity space to create volumes.

full disk encryption (FDE)

A type of drive technology that can encrypt all data being written to its disk media.

H**HBA host port**

The physical and electrical interface on the host bus adapter (HBA) that provides for the connection between the host and the controller. Most HBAs will have either one or two host ports. The HBA has a unique World Wide Identifier (WWID) and each HBA host port has a unique WWID.

heterogeneous hosts

Hosts with different operating systems that share access to the same storage array.

host

A computer that is attached to a storage array. A host accesses volumes assigned to it on the storage array. The access is through the HBA host ports or through the iSCSI host ports on the storage array.

host group

A logical entity that identifies a collection of hosts that share access to the same volumes.

hot spare drive

A spare drive that contains no data and that acts as a standby in case a drive fails in a RAID Level 1, RAID Level 3, RAID Level 5, or RAID Level 6 volume. The hot spare drive can replace the failed drive in the volume.

I**in-band management**

A method to manage a storage array in which a storage management station sends commands to the storage array through the host input/output (I/O) connection to the controller.

L**logical unit number (LUN)**

The number assigned to the address space that a host uses to access a volume. Each host has its own LUN address space. Therefore, the same LUN can be used by different hosts to access different volumes.

M**media scan**

A background process that runs on all volumes in the storage array for which it has been enabled. A media scan provides error detection on the drive media. The media scan process scans all volume data to verify that it can be accessed. Optionally, the media scan process also scans the volume redundancy data.

mirror repository volume

A special volume on the storage array that is created as a resource for each controller in both local storage arrays and remote storage arrays. The controller stores duplicate information on the mirror repository volume, including information about remote writes that are not yet written to the secondary volume. The controller uses the mirrored information to recover from controller resets and from accidental powering-down of storage arrays.

N**network management station (NMS)**

A console with installed network management software that is Simple Network Management Protocol (SNMP) compliant. The NMS receives and processes information about managed network devices in a form that is supported by the Management Information Base (MIB) that the NMS uses.

SANtricity ES Storage Manager provides information about critical events, using SNMP trap messages, to the configured NMS.

node

CONTEXT [Network] [Storage System] An addressable entity connected to an input/output (I/O) bus or network. Used primarily to refer to computers, storage devices, and storage subsystems. The component of a node that connects to the bus or network is a port. (The Dictionary of Storage Networking Terminology)

O**out-of-band management**

A method to manage a storage array in which a storage management station sends commands to the storage array through the Ethernet connections on the controller.

P**parity**

A method that provides complete data redundancy while requiring that only a fraction of the storage capacity of mirroring. The data and parity blocks are divided between the drives so that if any single drive is removed (or fails), the data on the drive can be reconstructed. Data is reconstructed by using the data on the remaining drives. The parity data might exist on only one drive, or the parity data might be distributed between all of the drives in the Redundant Array of Independent Disks (RAID) group.

premium feature

A feature that is not available in the standard configuration of the storage management software.

primary volume

A standard volume in a mirror relationship that accepts host input/output (I/O) and stores application data. When the mirror relationship is first created, data from the primary volume is copied in its entirety to the associated secondary volume. The primary volume contains the original user data in a mirroring relationship.

protocol

CONTEXT [Fibre Channel] [Network] [SCSI] A set of rules for using an interconnect or a network so that information conveyed on the interconnect can be correctly interpreted by all parties to the communication. Protocols include such aspects of communication as data representation, data item ordering, message formats, message and response sequencing rules, block data transmission conventions, timing requirements, and so forth. (The Dictionary of Storage Networking Terminology, 2004)

R**RAID Level 0**

A level of non-redundant Redundant Array of Independent Disks (RAID) in which data is striped across a volume or volume group. RAID Level 0 provides high input/output (I/O) performance and works well for non-critical data. All drives are available for storing user data; however, data redundancy does not exist. Data availability is more at risk than with other RAID levels, because any single drive failure causes data loss and a volume status of Failed.

RAID Level 0 is not actually RAID unless it is combined with other features to provide data and functional redundancy, regeneration, and reconstruction, such as RAID Level 1+0 or RAID Level 5+0.

RAID Level 1

A redundant Redundant Array of Independent Disks (RAID) level in which identical copies of data are maintained on pairs of drives, also known as mirrored pairs. RAID Level 1 uses disk mirroring to make an exact copy from one drive to another drive.

RAID Level 1 offers the best data availability, but only half of the drives in the volume group are available for user data. If a single drive fails in a RAID Level 1 volume group, all associated volumes become degraded, but the mirrored drive allows access to the data. RAID Level 1 can survive multiple drive failures as long as no more than one failure exists per mirrored pair. If a drive pair fails in a RAID Level 1 volume group, all associated volumes fail, and all data is lost.

RAID Level 3

A high-bandwidth mode Redundant Array of Independent Disks (RAID) level in which both user data and redundancy data (parity) are striped across the drives. The equivalent of one drive's capacity is used for redundancy data. RAID Level 3 is good for large data transfers in applications, such as multimedia or medical imaging, that read and write large sequential blocks of data.

If a single drive fails in a RAID Level 3 volume group, all associated volumes become degraded, but the redundancy data allows access to the data. If two or more drives fail in a RAID Level 3 volume group, all associated volumes fail, and all data is lost.

RAID Level 5

A high input/output (I/O) Redundant Array of Independent Disks (RAID) level in which data and redundancy are striped across a volume group or volume. The equivalent of one drive's capacity is used for redundancy data. RAID Level 5 is good for multiuser environments, such as database or file system storage, where typical I/O size is small, and there is a high proportion of read activity.

If a single drive fails in a RAID Level 5 volume group, then all associated volumes become degraded, but the redundancy data allows access to the data. If two or more drives fail in a RAID Level 5 volume group, then all associated volumes fail, and all data is lost.

RAID Level 6

A further development of Redundant Array of Independent Disks (RAID) Level 5. RAID Level 6 protects against simultaneous failure of two member drives by using two independent error correction schemes. Although RAID Level 6 provides ultra-high data reliability, its write penalty is even more severe than that of RAID Level 5 because redundant information must be generated and written twice for each application update. As with RAID Level 4 and RAID Level 5, the write penalty in RAID Level 6 is often mitigated by other storage technologies, such as caching.

RAID Level 10

A striping and mirroring mode used for high performance.

redundancy (data)

Additional information stored along with user data that enables a controller to reconstruct lost data. Redundant Array of Independent Disks (RAID) Level 1 uses mirroring for redundancy. RAID Level 3, RAID Level 5, and RAID Level 6 use redundancy information, sometimes called parity, that is constructed from the data bytes and is striped along with the data on each drive.

redundancy (hardware)

The use of some hardware components that take over operation when the original hardware component fails. For example, if one power-fan canister fails in a tray, the second power-fan canister can take over the power and cooling requirements for the tray.

redundancy check

A scan of volume redundancy data, performed as a part of a background media scan.

Redundant Array of Independent Disks (RAID)

CONTEXT [Storage System] A disk array in which part of the physical storage capacity is used to store redundant information about user data stored on the remainder of the storage capacity. The redundant information enables regeneration of user data in the event that one of the array's member disks or the access path to it fails.

Although it does not conform to this definition, disk striping is often referred to as RAID (RAID Level 0). (The Dictionary of Storage Networking Terminology)

remote mirror

A mirrored volume pair that consists of a primary volume at the primary site and a secondary volume at a secondary, remote site.

The secondary, remote volume is unavailable to secondary host applications while mirroring is underway. In the event of disaster at the primary site, the user can fail over to the secondary site. The failover is done by performing a role reversal to promote the secondary volume to a primary volume. Then the recovery host will be able to access the newly promoted volume, and business operations can continue.

remote mirroring

A configuration in which data on one storage array (the primary storage array) is mirrored across a fabric storage area network (SAN) to a second storage array (the secondary storage array). In the event that the primary storage array fails, mirrored data at the secondary site is used to reconstruct the data in the volumes.

role reversal

The acts of promoting the secondary volume to be the primary volume of a mirrored volume pair and demoting the primary volume to be the secondary volume.

S

secondary volume

A standard volume in a mirror relationship that maintains a mirror (or copy) of the data from its associated primary volume. The secondary volume is available for host read requests only. Write requests to the secondary volume are not permitted. In the event of a disaster or catastrophic failure of the primary site, the secondary volume can be promoted to a primary role.

Simple Network Management Protocol (SNMP)

CONTEXT [Network] [Standards] An IETF protocol for monitoring and managing systems and devices in a network. The data being monitored and managed is defined by a Management Information Base (MIB). The functions supported by the protocol are the request and retrieval of data, the setting or writing of data, and traps that signal the occurrence of events. (The Dictionary of Storage Networking Terminology)

simplex

A one-way transmission of data. In simplex communication, communication can only flow in one direction and cannot flow back the other way.

snapshot repository volume

A volume in the storage array that is made as a resource for a snapshot volume. A snapshot repository volume holds snapshot volume metadata and copy-on-write data for a specified snapshot volume.

snapshot volume

A point-in-time image of a standard volume. A snapshot is the logical equivalent of a complete physical copy, but a snapshot is created much more quickly than a physical copy. In addition, a snapshot requires less unconfigured capacity.

SNMP trap

A notification event issued by a managed device to the network management station when a significant event occurs. A significant event is not limited to an outage, a fault, or a security violation.

Solid State Disk (SSD)

[Storage System] A disk whose storage capability is provided by solid-state random access or flash memory rather than magnetic or optical media.

A solid state disk generally offers very high access performance compared to that of rotating magnetic disks, because it eliminates mechanical seek and rotation time. It may also offer very high data transfer capacity. Cost per byte of storage, however, is typically higher. (The Dictionary of Storage Networking Terminology)

source volume

A standard volume in a volume copy that accepts host input/output (I/O) and stores application data. When the volume copy is started, data from the source volume is copied in its entirety to the target volume.

standard volume

A logical component created on a storage array for data storage. Standard volumes are also used when creating snapshot volumes and remote mirrors.

storage management station

A computer running storage management software that adds, monitors, and manages the storage arrays on a network.

storage partition

A logical entity that is made up of one or more storage array volumes. These storage array volumes can be accessed by a single host or can be shared with hosts that can be part of a host group.

striping

CONTEXT [Storage System] Short for data striping; also known as Redundant Array of Independent Disks (RAID) Level 0 or RAID 0. A mapping technique in which fixed-size consecutive ranges of virtual disk data addresses are mapped to successive array members in a cyclic pattern. (The Dictionary of Storage Networking Terminology)

T**target volume**

A standard volume in a volume copy that contains a copy of the data from the source volume.

topology

The logical layout of the components of a computer system or network and their interconnections. Topology deals with questions of what components are directly connected to other components from the standpoint of being able to communicate. It does not deal with questions of physical location of components or interconnecting cables. (The Dictionary of Storage Networking Terminology)

U**Unconfigured Capacity node**

The capacity present in the storage array from drives that have not been assigned to a volume group.

V**volume**

The logical component created for the host to access storage on the storage array. A volume is created from the capacity available on a volume group. Although a volume might consist of more than one drive, a volume appears as one logical component to the host.

Volume Copy

A premium feature that copies data from one volume (the source volume) to another volume (the target volume) within a single storage array.

volume group

A set of drives that is logically grouped and assigned a RAID level. Each volume group created provides the overall capacity needed to create one or more volumes.

W**write caching**

An operation in which data is moved from the host to the cache memory on the controllers. This operation allows the controllers to copy the data to the drives that comprise a volume. Write caching helps improve data throughput by storing the data from the host until the controller can access the volume and move the data.

Storage System Site Preparation Guide

This guide defines the hardware, power, and environmental requirements that must be met prior to the installation of the following products:

- The Model 3040 40U cabinet
- The CE7900 controller tray
- The CE7922 controller tray
- The CE6998 controller tray
- The CE2600 controller-drive tray
- The CE2600-60 controller-drive tray
- The CE4900 controller-drive tray
- The CDE3994 controller-drive tray
- The AM1331 and AM1333 controller-drive trays
- The AM1532 controller-drive tray
- The AM1932 controller-drive tray
- The DE1600 drive tray
- The DE5600 drive tray
- The DE6600 drive tray
- The DE6900 drive tray
- The FC4600 drive tray
- The AT2655 drive tray
- The FC2610 drive tray
- The FC2600 drive tray
- The DM1300 drive tray

About This Guide

This guide contains site preparation information that defines the hardware, power, and environmental requirements.

Use this guide prior to delivery and installation to make sure that the appropriate and required preparation tasks are completed. This guide does not explain procedures for installing the hardware trays or for installing and configuring the software.

This guide helps you make decisions about ventilation, electrical power, floor loading, and network configuration. Conduct a power survey to make sure that the storage array's input power is free of noise, spikes, and fluctuations.

Refer to the Product Release Notes for SANtricity ES Storage Manager® for any updated information regarding hardware, software, or firmware products that might not be covered in this guide.

Intended Readers

This guide is intended for system operators, system administrators, and technical support personnel who are responsible for installation and setup of the storage array. They must have the following skills:

- Familiarity with computer system operations
- Understanding of disk storage technology, Redundant Array of Independent Disks (RAID) concepts, networking, and Fibre Channel, Infiniband, and iSCSI technologies
- Basic knowledge of storage area network (SAN) hardware functionality (controllers, drives, and hosts) and SAN cabling

Related Publications

The following guides have information that is related to the site preparation process. You can obtain any of these documents by contacting a Customer and Technical Support representative or your storage representative.

- Model 3040 40U Cabinet Hardware Installation Guide
- CE7900 Controller Tray Initial Setup Guide
- CE7922 Controller Tray Initial Setup Guide
- CE6998 Controller Tray Initial Setup Guide
- CE2600 Controller-Drive Tray Initial Setup Guide
- CE2600-60 Controller-Drive Tray Initial Setup Guide
- CE4900 Controller-Drive Tray Initial Setup Guide
- CDE3994 Controller-Drive Tray Initial Setup Guide
- AM1331 and AM1333 Controller-Drive Trays Initial Setup Guide
- AM1532 Controller-Drive Tray Initial Setup Guide
- AM1932 Controller-Drive Tray Initial Setup Guide
- DE1600 Drive Tray Initial Setup Guide
- DE5600 Drive Tray Initial Setup Guide
- DE6600 Drive Tray Initial Setup Guide
- DE6900 Drive Tray Initial Setup Guide
- FC4600 Drive Tray Initial Setup Guide
- AT2655 Drive Tray Initial Setup Guide
- FC2610 Drive Tray Initial Setup Guide
- FC2600 Drive Tray Initial Setup Guide
- DM1300 Drive Tray Initial Setup Guide
- Product Release Notes for SANtricity ES Storage Manager

Web Address

For information related to the products mentioned in this document, go to the following website:

http://www.lsi.com/storage_home/products_home/external_raid/index.html

Additional Information

From the LSI Technical Support website, you can find contact information, query the knowledge base, submit a service request, download patches, or search for documentation. Visit the LSI Technical Support website at: <http://www.lsi.com/support/index.html>.

Specifications of the Model 3040 40U Cabinet

The Model 3040 40U cabinet has these standard features:

- A detachable rear door
- Standard Electronic Industry Association (EIA) support rails that provide mounting holes for installing devices into a standard 48.3-cm (19-in.) wide cabinet
- Four roller casters and four adjustable leveling feet that are located beneath the cabinet for moving the cabinet and then leveling the cabinet in its final location
- A stability foot that stabilizes the cabinet after it is installed in its permanent location
- Access openings for interface cables
- Two AC power distribution units (PDUs) that allow integrated power connection and power handling capacity for controller trays, controller-drive trays, and drive trays



WARNING (W05) Risk of bodily injury – If the bottom half of the cabinet is empty, do not install components in the top half of the cabinet. If the top half of the cabinet is too heavy for the bottom half, the cabinet might fall and cause bodily injury. Always install a component in the lowest available position in the cabinet.



WARNING (W07) Risk of bodily injury – Only move a populated cabinet with a forklift or adequate help from other persons. Always push the cabinet from the front to prevent it from falling over.

A fully populated cabinet can weigh more than 909 kg (2000 lb). The cabinet is difficult to move, even on a flat surface. If you must move the cabinet along an inclined surface, remove the components from the top half of the cabinet, and make sure that you have adequate help.

Components of the Model 3040 40U Cabinet – Front View and Rear View

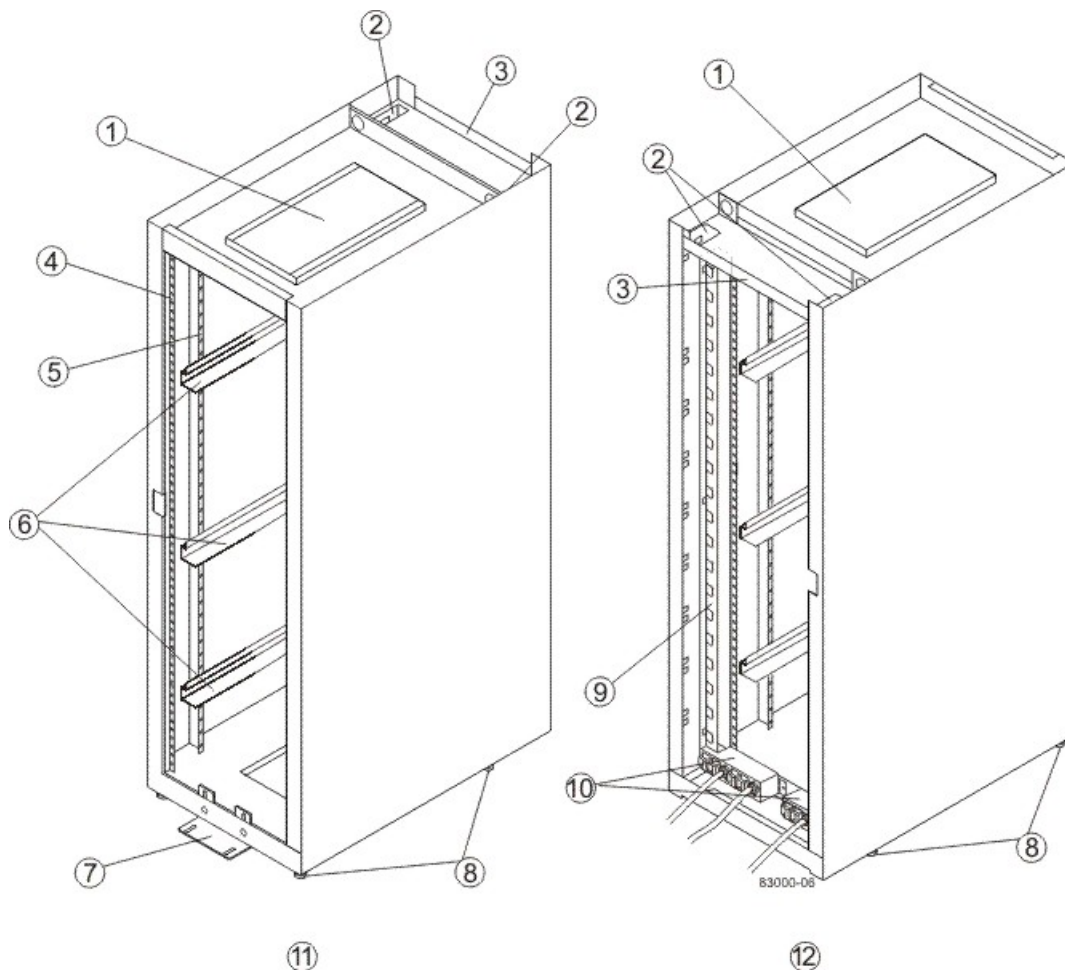

1. Ventilation Cover
2. Interface Cable Access Openings
3. Rear Plate
4. EIA Support Rails
5. Vertical Support Rails
6. Cabinet Mounting Rails
7. Stability Foot
8. Adjustable Leveling Feet
9. Power Strip
10. AC Power Distribution Units
11. Front of the Cabinet
12. Rear of the Cabinet

You can configure the cabinet to meet your data storage needs. Standard cabinet configurations consist of a combination of these types of trays:

- **Controller tray** – Contains one or two controllers, one interconnect-battery canister, and two power-fan canisters.
- **Controller-drive tray** – Contains drives, redundant cooling fans and power supplies, and, depending on the model, one or two controllers.
- **Drive tray** – Contains drives, redundant cooling fans and power supplies, and one or two environmental services monitors (ESMs).

Model 3040 40U Cabinet Configurations

The following table lists the limitations when populating your cabinet with DE6900 drive trays.

DE6900 Drive Trays That Can Be Installed in the Cabinet

| Number of Controller Trays | Controller Tray | Maximum Number of DE6900 Drive Trays |
|--|------------------------|--------------------------------------|
| 1 (72A PDUs are required if you are installing DE6900 drive trays) | CE7900 controller tray | 8 |
| 2 (72A PDUs are required if you are installing DE6900 drive trays) | CE7900 controller tray | 8 |

DE6600 Drive Trays That Can Be Installed in the Cabinet

| Number of Controller Trays | Controller Tray | Maximum Number of DE6900 Drive Trays |
|--|---------------------------------|--------------------------------------|
| 1 (72A PDUs are required if you are installing DE6600 drive trays) | CE2600-60 controller-drive tray | 2 |

The following table displays the maximum combination of FC4600 drive trays allowed in one cabinet.

FC4600 Drive Trays That Can Be Installed in the Cabinet

| Number of Controller Trays or Controller-Drive Trays and the Specific Types | | Maximum Number of FC4600 Drive Trays |
|---|---|--------------------------------------|
| 0 | No controller trays or controller-drive trays | 13 |
| 1 | CE7900 controller tray, CE7922 controller tray, or CE6998 controller tray | 12 |
| | CE4900 controller-drive tray or CDE3994 controller-drive tray | 6 |
| 2 | CE7900 controller trays, CE7922 controller trays, CE6998 controller trays, or CE4900 controller-drive trays | 10 |
| | CE4900 controller-drive tray or CDE3994 controller-drive tray | 11 |

| Number of Controller Trays or Controller-Drive Trays and the Specific Types | | Maximum Number of FC4600 Drive Trays |
|---|---|--------------------------------------|
| 3 | CE7900 controller trays, CE7922 controller trays, CE6998 controller trays, or CE4900 controller-drive trays | 9 |
| | CE4900 controller-drive tray or CDE3994 controller-drive tray | 10 |
| 4 | CE7900 controller trays, CE7922 controller trays, CE6998 controller trays, or CE4900 controller-drive trays | 8 |
| | CE4900 controller-drive tray or CDE3994 controller-drive tray | 9 |
| 5 | CE4900 controller-drive tray or CDE3994 controller-drive tray | 8 |

The following table displays the maximum combination of DM1300 drive trays allowed in one cabinet.

DM1300 Drive Trays That Can Be Installed in the Cabinet

| Number of Controller-Drive Trays | Controller-Drive Tray | Maximum Number of DM1300 Drive Trays |
|----------------------------------|--|--------------------------------------|
| 1 | AM1331 or AM1333 controller-drive tray or AM1532 controller-drive tray or AM1932 controller-drive tray | 3 |
| 2 | AM1331 or AM1333 controller-drive trays or AM1532 controller-drive tray or AM1932 controller-drive trays | 6 |
| 3 | AM1331 or AM1333 controller-drive trays or AM1532 controller-drive tray or AM1932 controller-drive trays | 9 |
| 4 | AM1331 or AM1333 controller-drive trays or AM1532 controller-drive tray or AM1932 controller-drive trays | 12 |
| 5 | AM1331 or AM1333 controller-drive trays or AM1532 controller-drive tray or AM1932 controller-drive trays | 15 |

 **NOTE** These configurations are based on the standard storage array configurations that are shipped from the factory. The number of controller trays, controller-drive trays, and drive trays in a cabinet can be modified at the customer site.

Model 3040 40U Cabinet Dimensions

Make sure that the area where you will place the cabinet has sufficient space to install and service the cabinet and the storage array components.

Dimensions of the Model 3040 40U Cabinet – Front View

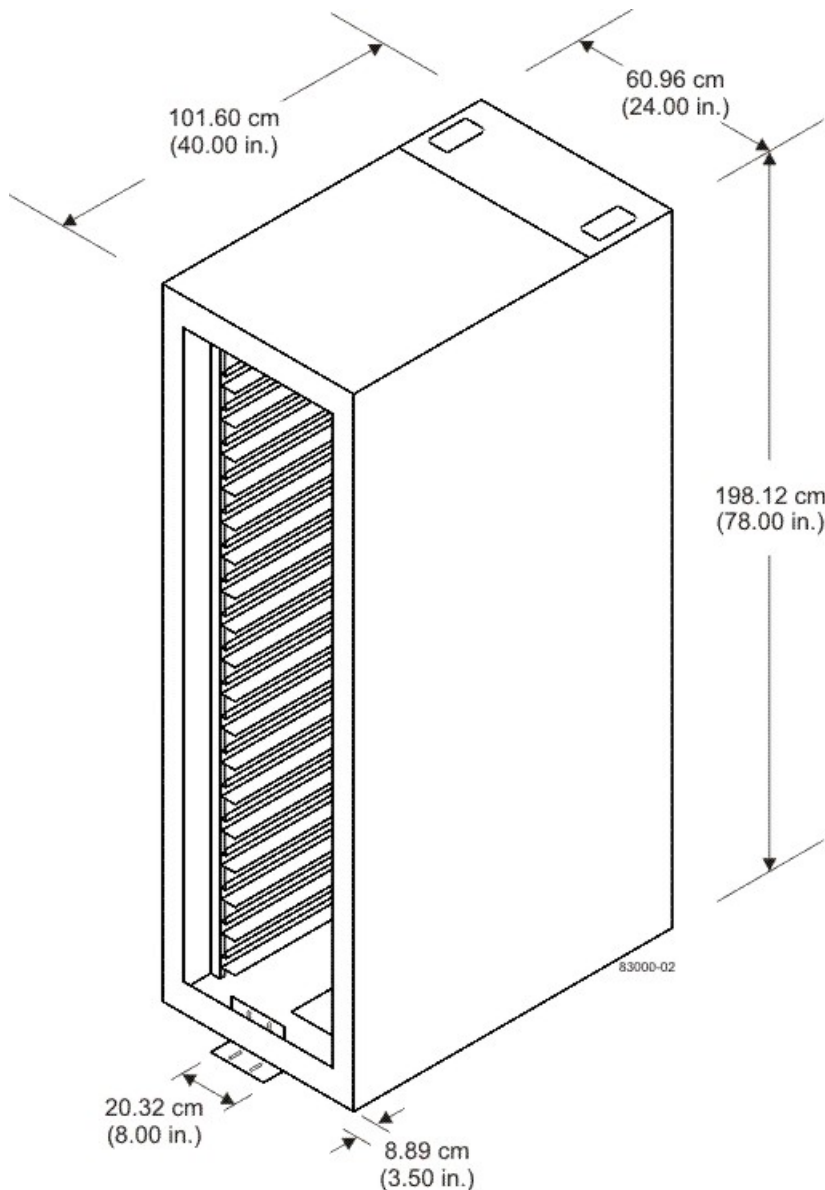

Model 3040 40U Cabinet Weights

⚠ ATTENTION Risk of damage to flooring – The weight of the cabinet might exceed the flooring load specifications. A fully-loaded 3040 40U cabinet weighs up to 1090 kg (2400 lb). Before you install your components, make sure that your flooring is strong enough to support the weight of the cabinet and its components.

Record the total weight of your cabinet and its components. Keep this information in a place where you can refer to it when you check for flooring load restrictions or elevator weight restrictions.

Weights of the Model 3040 40U Cabinet, Trays, and Crate

| Component | Weight | Notes |
|---------------------------------------|----------------------|------------------------------------|
| Cabinet | 138.80 kg (306.0 lb) | Empty with the rear door installed |
| Power distribution unit (PDUs [pair]) | 19.96 kg (44.0 lb) | |
| Mounting rails (pair) | 1.59 kg (3.50 lb) | |
| CE7900 controller tray | 36.79 kg (81.1 lb) | Maximum configuration |
| CE7922 controller tray | 36.79 kg (81.1 lb) | Maximum configuration |
| CE6998 controller tray | 36.79 kg (81.1 lb) | Maximum configuration |
| CE2600 controller-drive tray | 27 kg (59.52 lb) | Maximum configuration |
| CE2600-60 controller-drive tray | 105.2 kg (232.0 lb) | Maximum configuration |
| CE4900 controller-drive tray | 38.15 kg (84.1 lb) | Maximum configuration |
| CDE3994 controller-drive tray | 38.60 kg (85.1 lb) | Maximum configuration |
| AM1331 controller-drive tray | 25.58 kg (63.0 lb) | Maximum configuration |
| AM1333 controller-drive tray | 25.58 kg (63.0 lb) | Maximum configuration |
| AM1932 controller-drive tray | 25.58 kg (63.0 lb) | Maximum configuration |
| DE6600 drive tray | 105.2 kg (232.0 lb) | Maximum configuration |
| DE6900 drive tray | 100.0 kg (220.0 lb) | Maximum configuration |
| FC4600 drive tray | 42.18 kg (93.0 lb) | Maximum configuration |
| AT2655 drive tray | 40.0 kg (88.0 lb) | Maximum configuration |
| FC2610 drive tray | 40.0 kg (88.0 lb) | Maximum configuration |
| FC2600 drive tray | 40.4 kg (89.0 lb) | Maximum configuration |

| Component | Weight | Notes |
|---|----------------------|-----------------------|
| DM1300 drive tray | 25.86 kg (57.0 lb) | Maximum configuration |
| Shipping crate (worldwide shipments only) | 136.08 kg (300.0 lb) | Empty |

Model 3040 40U Cabinet Temperature and Humidity

An air-conditioned cooling environment helps to make sure that the ambient temperatures surrounding the cabinet are maintained. This type of environment helps your storage array components to run at operating temperatures that will enhance the overall reliability of your storage.

Temperature Requirements and Humidity Requirements for the Model 3040 40U Cabinet

| Environment | Temperature Range | Temperature Change | Relative Humidity |
|---|-----------------------------------|----------------------------------|-------------------|
| Operating* | 10°C to 35° C (50°F to 95°F) | 10°C per hour (18°F per hour) | 20% to 80% |
| Storage | -10°C to 45°C (14°F to 113°F) | 15°C per hour (27°F per hour) | 10% to 90% |
| Transit | -40°C to 65°C (-40°F to 149°F) | 20°C per hour (36°F per hour) | 5% to 95% |
| *If you plan to operate a storage array at an altitude between 1000 m to 3000 m (3280 ft to 9842 ft) above sea level, lower the environmental temperature 1.7°C (3.3°F) for every 1000 m (3280 ft) above sea level. | | | |

The maximum allowed dew point is 28°C (82°F), with a maximum humidity gradient of 10 percent per hour.

Model 3040 40U Cabinet Altitude Ranges

Altitude Ranges for the Model 3040 40U Cabinet

| Environment | Altitude |
|-------------|---|
| Operating | 30.5 m (100 ft) below sea level to 3000 m (9842 ft) above sea level |
| Storage | 30.5 m (100 ft) below sea level to 3000 m (9842 ft) above sea level |
| Transit | 30.5 m (100 ft) below sea level to 12,000 m (40,000 ft) above sea level |

Model 3040 40U Cabinet Airflow, Heat Dissipation, and Service Clearances

Air flows through the cabinet from the front to the rear. Allow at least 76 cm (30 in.) of clearance in front of the cabinet, and at least 61 cm (24 in.) of clearance behind the cabinet for service clearance, ventilation, and heat dissipation. The total depth required for the cabinet plus clearance is 240 cm (94 in.). The cabinet does not require side clearances.

Area Requirements for the Model 3040 40U Cabinet – Top View

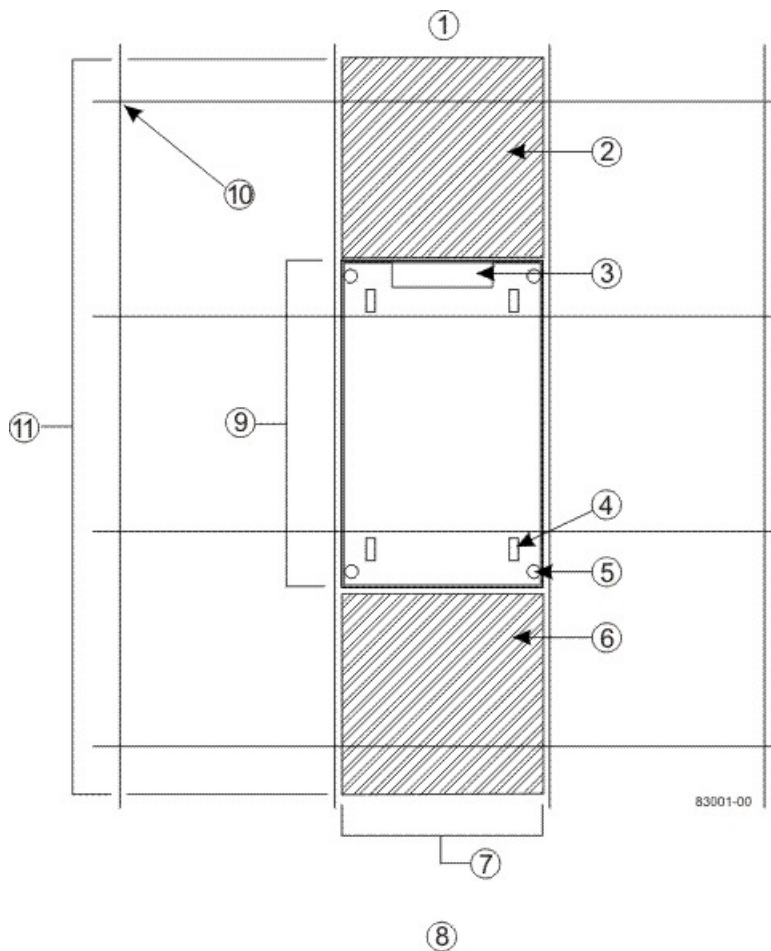

1. Rear of the Cabinet
2. Required Rear Service Area – 61 cm (24 in.)
3. Cable Access
4. Roller Caster
5. Adjustable Leveling Foot
6. Required Front Service Area – 76 cm (30 in.)
7. Width of the Cabinet – 61 cm (24 in.)
8. Front of the Cabinet
9. Depth of the Cabinet – 102 cm (40 in.)
10. Computer Floor Grid – 61 cm x 61 cm (24 in. x 24 in.)
11. Total Clearance Depth – 240 cm (94 in.)

Do not place anything in front of the cabinet or behind the cabinet that would interfere with air flow. The cabinet's ventilation is essential to make sure that ambient air is available to correctly cool your storage array.

Total heat dissipation is a function of the number and type of trays that are installed in the cabinet. Use the table in [Model 3040 40U Cabinet Power Requirements](#) to calculate the total heat dissipation for your configuration. For the total Btu/Hr for the cabinet, add the value for each of the individual trays together.

Model 3040 40U Cabinet Site Wiring and Power

The AC power distribution units in the cabinet use common industrial wiring.

- **AC power source** – The AC power source must provide the correct voltage, current, and frequency that are specified on the tray and the serial number label.
- **Protective ground** – Site wiring must include a protective ground connection to the AC power source.



NOTE *Protective ground* is also known as safety ground or chassis ground.

- **Circuit overloading** – Power circuits and associated circuit breakers must provide enough power and overload protection. An external, independent AC power source that is isolated from large switching loads is recommended to run your storage array. The power going to the AC power distribution boxes and other components in the cabinet should not have air-conditioning motors, elevator motors, or factory loads on the same circuit.
- **Tray power distribution** – All units attached to the two individual power strip outlets inside the cabinet must be wide-ranging between 180 VAC and 264 VAC, 50–60 Hz.
- **Power interruptions** – The cabinet and trays can withstand these applied voltage interruptions:
 - **Input transient** – 50 percent of the nominal voltage
 - **Duration** – One-half cycle
 - **Maximum frequency** – Once every 10 seconds
- **Power failures** – If a total power failure occurs, the trays in the cabinet automatically perform a power#on recovery sequence without operator intervention.

Model 3040 40U Cabinet Power Requirements

AC Power Requirements for the Model 3040 40U Cabinet

| Parameter | Requirement |
|--|--------------------|
| Nominal voltage | 200 VAC to 240 VAC |
| Frequency | 50 Hz to 60 Hz |
| Nominal current (typical) Varies depending upon the number and type of trays that are installed in the cabinet. | 10.0 A to 24.0 A |

The Model 3040 40U cabinet contains power strips that provide either 48A or 72A of usable power.

The 48A power strips provide up to 48A of usable power through four 12A banks of power. This power is provided to 21 power outlets that are located in the rear of the cabinet.

The 72A power strips provide up to 72A of usable power through six 12A banks of power. This power is provided by 24 ICE320 power outlets on each power distribution unit (PDU). The 72A power strips are only used with the DE6900 drive tray.



ATTENTION Risk of exceeding maximum amperage – You must calculate the load of the devices in the cabinet to make sure that you do not exceed the 24.0 A maximum. As an example, one controller tray (2.2 A) and four drive trays (1.8 A each) would draw approximately 9.4 A (2.2 + 1.8 + 1.8 + 1.8 + 1.8).

Power Calculations and Heat Calculations for the Model 3040 40U Cabinet

| Component | KVA | Watts | Btu/ Hr | Amps (240 VAC) |
|--|------------|--------------|--------------------|---------------------------|
| Cabinet PDU (for 48A PDUs) | 9.60* | 9600* | 32,784* | |
| Cabinet PDU (for 72A PDUs) | 14.4 | 14400 | 49,176 | |
| Cabinet PDU/12A bank (for both 48A and 72A PDUs) | 2.40* | 2400* | 8196* | |
| CE7900 controller tray | 0.562 | 540 | 1842 | 2.25 |
| CE7922 controller tray | 0.562 | 540 | 1842 | 2.25 |
| CE6998 controller tray | 0.546 | 525 | 1811 | 2.19 |
| CE2600-60 controller-drive tray | 1.268 | 1222 | 4180 | 6.30 |
| CE4900 controller-drive tray | 0.624 | 600 | 2047 | 2.50 |
| CDE3994 controller-drive tray | 0.624 | 600 | 2047 | 2.50 |
| AM1331or AM1333 controller-drive tray | 0.398 | 394 | 1346 | 2.30 |
| AM1932 controller-drive tray | 0.458 | 453 | 1548 | 2.30 |
| DE6600 drive tray (requires 72A PDUs) | 1.268 | 1222 | 4180 | 6.30 |
| DE6900 drive tray (requires 72A PDUs) | 1.71 | 1632 | 5570 | 6.00 |
| FC4600 drive tray | 0.462 | 444 | 1517 | 1.85 |
| AT2655 drive tray | 0.329 | 316 | 1078 | 1.65 |
| FC2610 drive tray | 0.384 | 369 | 1526 | 1.65 |
| FC2600 drive tray | 0.375 | 366 | 1229 | 1.65 |
| DM1300 drive tray | 0.362 | 358 | 1224 | 2.30 |
| *The maximum ratings at 200 VAC. The Btu/Hr calculation is based on the maximum current rating that the power distribution unit can provide. | | | | |

Model 3040 40U Cabinet Grounding

To prevent personal injury or electrostatic discharge (ESD), make sure that the cabinet is correctly grounded. The ground must have the correct low impedance so that there is no build-up of voltage on any equipment or on any exposed surfaces. Grounding is especially important to eliminate shock hazards, and to facilitate the operation of circuit-protective devices.

Use good metal-to-metal bonding techniques, such as bared metal washers and internal star washers or external star washers. It is not enough to provide ground paths through anodized material or hinges. Never use sheet metal screws to attach a ground. Refer to the Underwriters Laboratory (UL) safety agency for more information about the correct grounding techniques to use.

Consider a low impedance grounding and lightning protection when you plan for and install an electrical system. Your electrical contractor must meet local code requirements and national code requirements when installing an electrical system.



NOTE Local codes and local standards might have more stringent requirements. Always comply with local codes.

Model 3040 40U Cabinet Power Distribution

The Model 3040 40U cabinet has two identical AC power distribution units, each of which has a separate power cord. Depending on your configuration, each AC power distribution unit supports either North American (USA and Canada) components or worldwide (excluding USA and Canada) components. Each AC power distribution unit includes these parts:

- Two cords per side, NEMA L6-30P or IEC 309
- Four circuit breakers per side, 15 A each, for 48A PDUs
- Six circuit breakers per side, 15 A each, for 72A PDUs
- Twenty IEC 320 power outlets per side, plus an additional outlet for the optional fan tray



NOTE For pluggable equipment, the electrical outlet must be installed near the equipment and must be easily accessible.

Circuit Breakers and Electrical Outlets for 48A PDUs

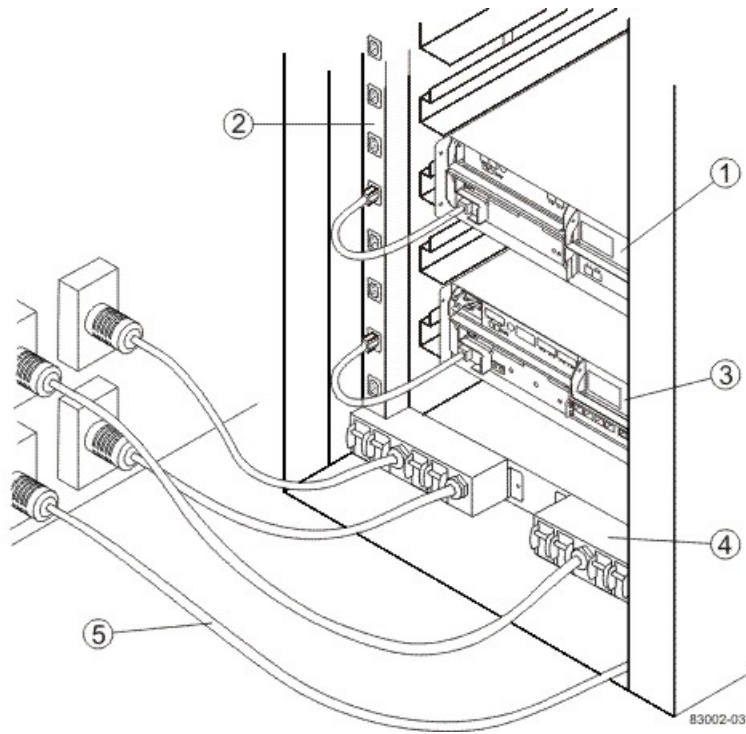

1. Controller Tray
2. Power Strip
3. Drive Tray
4. AC Power Distribution Unit
5. AC Power Cords

Circuit Breakers and Electrical Outlets for 72A PDUs

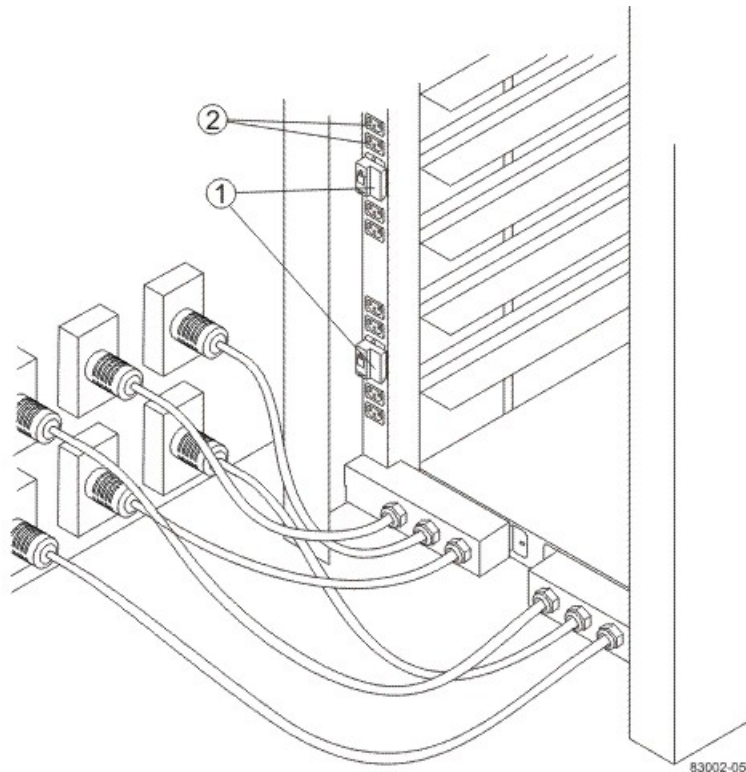

1. Circuit Breakers
2. Electrical Outlets

Model 3040 40U Cabinet Power Cords and Receptacles

The cabinet is equipped with two AC power distribution units. Each AC power distribution unit contains four 15-A circuit breakers on each side. Depending on your installation, the AC power distribution units in your cabinet have either North American (USA and Canada) power cords or worldwide (except USA and Canada) power cords. Connect each AC power distribution unit power cord to an independent power source outside of the cabinet.

NEMA L6-30 Power Cord and Receptacle (North American)

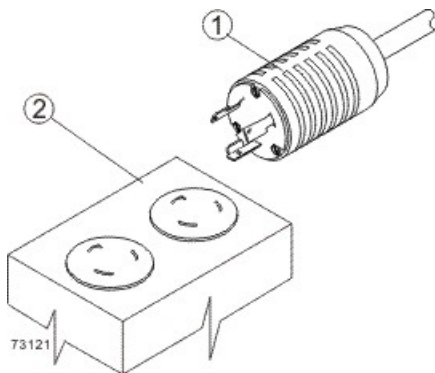

1. 250-VAC, 30-A Plug (North American)
2. Receptacle

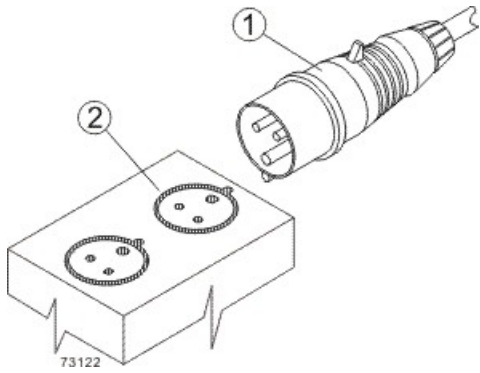
IEC 309 Power Cord and Receptacle (Worldwide, except USA and Canada)

1. 230-VAC, 32-A Plug (Worldwide, except USA and Canada)
2. Receptacle

Specifications of the CE7900 Controller Tray

The CE7900 controller tray is a compact, rackmounted unit that provides high-capacity disk storage for Fibre Channel and iSCSI environments, depending on the choice of the host interface card.

The CE7900 controller tray contains two power-fan canisters that include the power supplies and fans. One power-fan canister can provide electrical power and cooling to the controller tray if the other power-fan canister is turned off or malfunctions.

In the front, behind the bezel, are two power-fan canisters and one interconnect-battery canister.

CE7900 Controller Tray – Front View

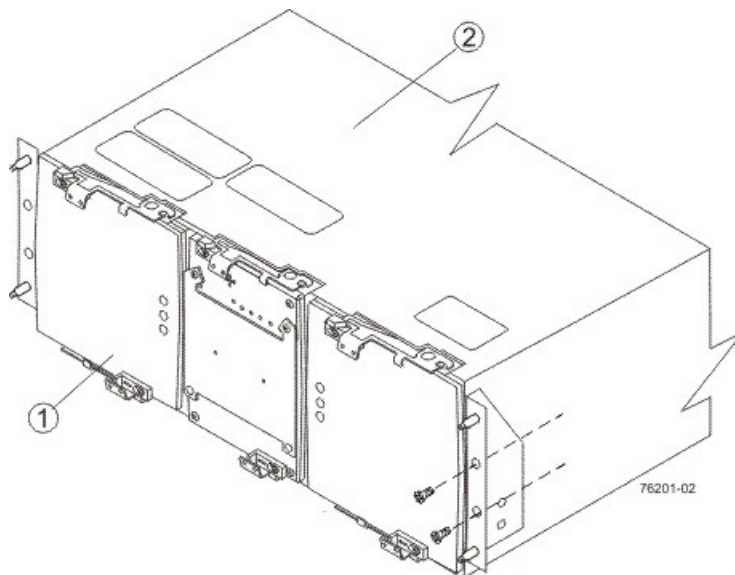

1. Power-Fan Canisters (Left and Right) and the Interconnect-Battery Canister (Center)
2. Top of the CE7900 Controller Tray

In the rear are two controller canisters with controller A on the top and controller B on the bottom. Controller A is upside down, and controller B is right-side up.

CE7900 Controller Tray – Rear View

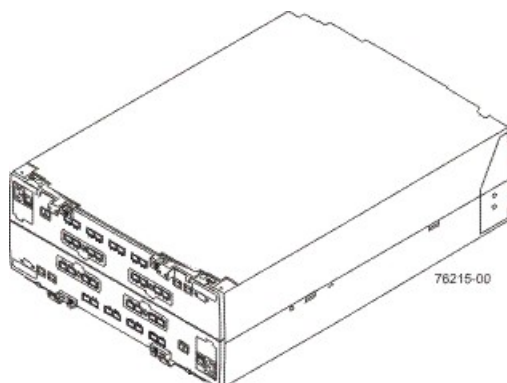

CE7900 Controller Tray Dimensions

The CE7900 controller tray conforms to the 48.3-cm (19-in.) rack standard.

Dimensions of the CE7900 Controller Tray – Front View

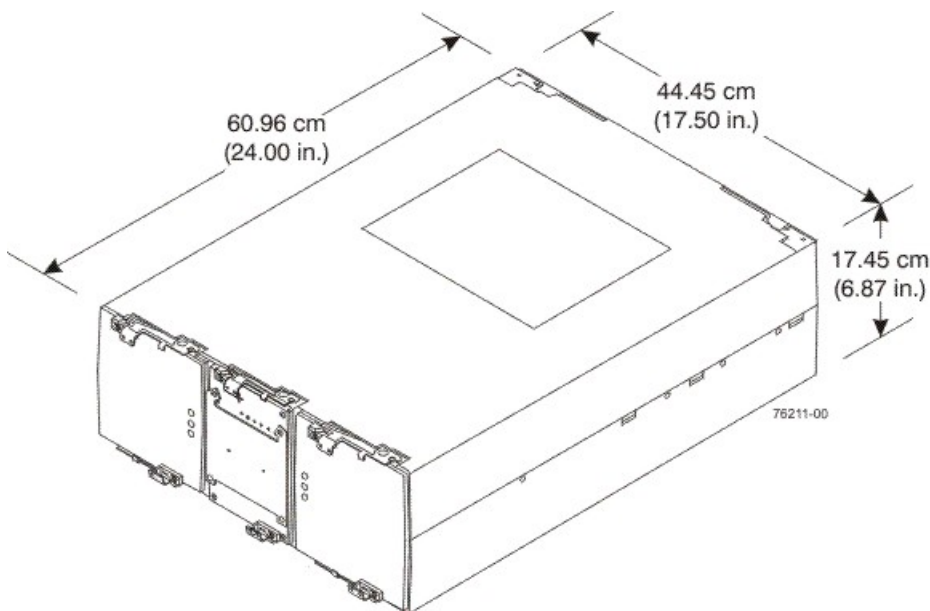

CE7900 Controller Tray Weight

Weights of the CE7900 Controller Tray

| Unit | Weight | | |
|---|--------------------|--------------------|---------------------|
| | Maximum* | Empty** | Shipping*** |
| CE7900 controller tray | 36.79 kg (81.1 lb) | 13.15 kg (29.0 lb) | 49.44 kg (109.0 lb) |
| *Maximum weight indicates a controller tray with all of its components installed. **Empty weight indicates a controller tray with the controller canisters, the power-fan canisters, and the interconnect-battery canister removed. ***Shipping weight indicates the maximum weight of a controller tray and all shipping material. | | | |

Component Weights of the CE7900 Controller Tray

| Component | Weight |
|--|--------------------|
| Controller canister | 6.24 kg (13.8 lb) |
| Power-fan canister | 3.719 kg (8.20 lb) |
| Interconnect-battery canister (with two batteries installed) | 4.082 kg (9.00 lb) |

| Component | Weight |
|------------------|--------------------|
| Battery canister | 1.134 kg (2.50 lb) |

CE7900 Controller Tray Shipping Dimensions

Shipping Carton Dimensions for the CE7900 Controller Tray

| Height | Width | Depth |
|---|----------------------|----------------------|
| 44.45 cm (17.50 in.) – Includes the height of the pallet. | 62.23 cm (24.50 in.) | 78.74 cm (31.00 in.) |

CE7900 Controller Tray Temperature and Humidity

Temperature Requirements and Humidity Requirements for the CE7900 Controller Tray

| Condition | Parameter | Requirement |
|--|------------------------|--------------------------------|
| Temperature* | Operating range | 10°C to 40°C (32°F to 104°F) |
| | Maximum rate of change | 10°C (18°F) per hour |
| | Storage range | –10°C to 65°C (14°F to 149°F) |
| | Maximum rate of change | 15°C (27°F) per hour |
| | Transit range | –40°C to 65°C (–40°F to 149°F) |
| | Maximum rate of change | 20°C (36°F) per hour |
| Relative humidity (no condensation) | Operating range | 20% to 80% |
| | Storage range | 10% to 93% |
| | Transit range | 5% to 95% |
| | Maximum dew point | 26°C (79°F) |
| | Maximum gradient | 10% per hour |
| *If you plan to operate a system at an altitude between 1000 m to 3048 m (3280 ft to 10,000 ft) above sea level, lower the environmental temperature 1.7°C (3.3°F) for every 1000 m (3280 ft) above sea level. | | |

CE7900 Controller Tray Altitude Ranges

Altitude Ranges for the CE7900 Controller Tray

| Environment | Altitude |
|-------------|---|
| Operating | 30.5 m (100 ft) below sea level to 3048 m (10,000 ft) above sea level |
| Storage | 30.5 m (100 ft) below sea level to 3048 m (10,000 ft) above sea level |
| Transit | 30.5 m (100 ft) below sea level to 12,000 m (40,000 ft) above sea level |

CE7900 Controller Tray Airflow and Heat Dissipation

Airflow goes from the front of the controller tray to the rear of the controller tray. Allow at least 76 cm (30 in.) of clearance in front of the controller tray and at least 61 cm (24 in.) of clearance behind the controller tray for service clearance, ventilation, and heat dissipation.

Airflow Through the CE7900 Controller Tray – Front View

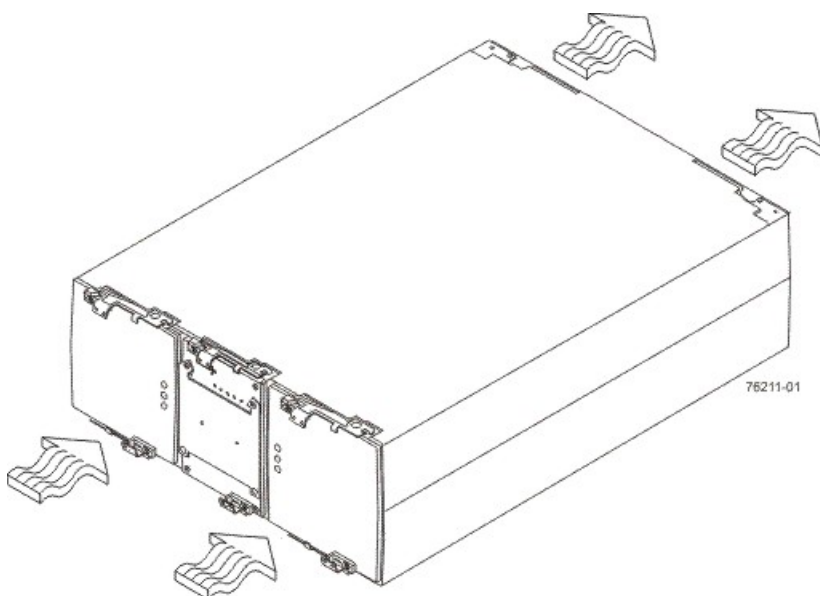

The tabulated power and heat dissipation values in the following table are the maximum measured operating power. Maximum configuration units are typically operated at higher data rates or have larger random access memory (RAM) capabilities.

Power Ratings and Heat Dissipation for the CE7900 Controller Tray

| Component | KVA | Watts (AC) | Btu/Hr | Amps (240 VAC) |
|------------------------|-------|------------|--------|----------------|
| CE7900 controller tray | 0.562 | 540 | 1842 | 2.25 |

CE7900 Controller Tray Acoustic Noise

Sound Levels for the CE7900 Controller Tray

| Measurement | Level |
|----------------|----------|
| Sound power | 6.0 bels |
| Sound pressure | 60 dBA |

CE7900 Controller Tray Site Wiring and Power

The agency ratings for the CE7900 controller tray are 5.40 A at 100 VAC and 2.25 A at 240 VAC. These ratings are the overall maximum currents for this system.

The CE7900 controller tray uses wide-ranging redundant power supplies that automatically accommodate voltages to the AC power source. The power supplies operate within the range of 90 VAC to 264 VAC, at a minimum frequency of 50 Hz and a maximum frequency of 60 Hz. Voltage levels can fluctuate within the specified range. The power supplies meet standard voltage requirements for both North American (USA and Canada) operation and worldwide (except USA and Canada) operation. The power supplies use standard industrial wiring with line-to-neutral or line-to-line power connections.

Keep this information in mind when you prepare the installation site for the controller tray:

- **Protective ground** – Site wiring must include a protective ground connection to the AC power source.



NOTE *Protective ground* is also known as safety ground or chassis ground.

- **Circuit overloading** – Power circuits and associated circuit breakers must provide enough power and overload protection. To prevent damage to the controller tray, isolate its power source from large switching loads, such as air-conditioning motors, elevator motors, and factory loads.
- **Power interruptions** – The controller tray can withstand these applied voltage interruptions:
 - **Input transient** – 50 percent of the nominal voltage
 - **Duration** – One-half cycle
 - **Maximum frequency** – Once every 10 seconds
- **Power failures** – If a total power failure occurs, the controller tray automatically performs a power-on recovery sequence without operator intervention after the power is restored.



NOTE When a power failure occurs, the controller tray uses battery power to back up the data that is in cache.

If you are installing a large storage array configuration, you must make sure that you are supplying the correct AC source voltages and not creating an over-current situation.

When calculating the cabinet's total power requirements, take the controller tray's 540 W and divide it by the cabinet's input voltage. If you are using 240 VAC, you obtain a maximum current of 2.25 A. Then add the amperage of each drive tray. If each drive tray uses 1.85 A, then 10 drive trays would use 18.5 A. In this example, your total storage array would use a rated maximum of 20.75 A.

CE7900 Controller Tray Power Cords and Receptacles

Each CE7900 controller tray is shipped with two AC power cords. Each AC power cord connects one of the power-fan canisters in the controller tray to an independent, external AC power source, such as a wall receptacle, or to any acceptable uninterruptible power supply (UPS).

AC Power Distribution to a CE7900 Storage Array – Rear View

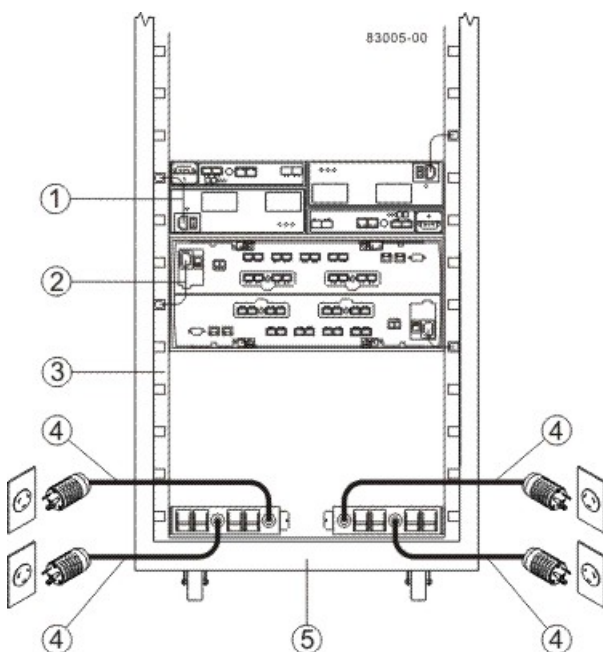

1. AC Power Cord to the Drive Tray
2. AC Power Cord to the CE7900 Controller Tray
3. Power Strip Portion of the Power Distribution Unit
4. AC Power Cord to the External Power Source
5. Rear of the Cabinet

The optional UPS equipment is either placed external from the cabinet, or it is placed at the bottom of the cabinet. UPS devices provide a continuous supply of electrical power when utility power is unavailable. Some UPS equipment can also provide power conditioning to protect your storage array from voltage spikes, line noise, and undesirable power fluctuations, such as brownout. Contact an electrician to help you select and install the correct UPS equipment.

The switched-rack power distribution unit (PDU) is also available for some customer-supplied cabinets. These new PDUs are stand-alone, network-manageable devices that allow programmable control of the power outlets. This capability enables you to control each outlet independently, manage power sequencing, and monitor the aggregate current draw through the switched-rack PDU. Additional equipment may be used to support temperature monitoring as well.

Preparing the Network for the Controllers

If you plan to use Ethernet connections from the storage management station to the controllers, you will use the out-of-band management method. For this configuration, meet with your network administrator before you order and install the equipment so that you can prepare for the setup and management of the devices on the IP network. Each controller uses its Ethernet management ports to connect to the IP network and communicate with the other devices on the IP network (often requiring a special application to set up the protocol).

Your network administrator can pre-assign the addresses that you need to manage the communication between the devices on the IP network. Depending on your storage configuration, you will need the following addresses:

- Up to two network IP addresses for each controller
- Up to two subnet mask addresses for each controller
- Either two IPv4 addresses (one static and one dynamic) or one IPv6 address for each controller
- A Dynamic Host Configuration Protocol (DHCP) address for each controller

If switches are used in your storage environment, you must know if zoning will be used, and how it will be configured.

Specifications of the CE7922 Controller Tray

The CE7922 controller tray is a compact, rackmounted unit that provides high-capacity disk storage for Infiniband environments.

The CE7922 controller tray contains two power-fan canisters that include the power supplies and fans. One power-fan canister can provide electrical power and cooling to the controller tray if the other power-fan canister is turned off or malfunctions.

In the front, behind the bezel, are two power-fan canisters and one interconnect-battery canister.

CE7922 Controller Tray – Front View

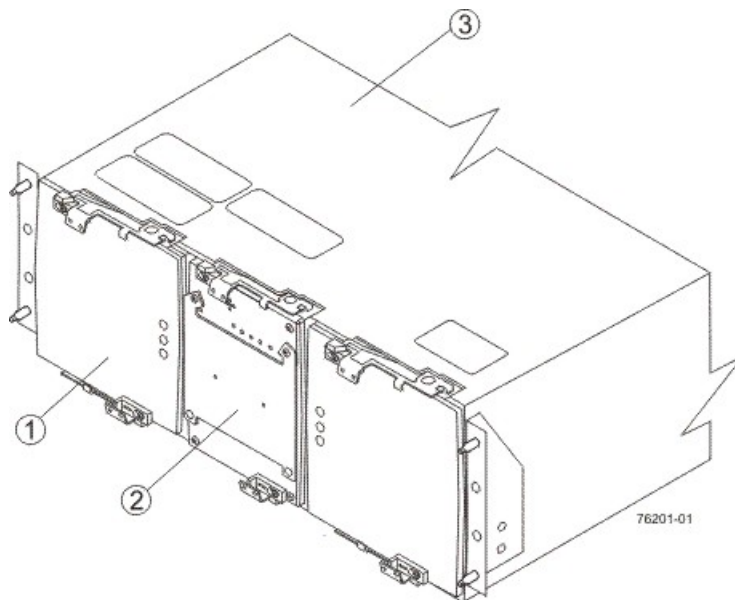

1. Power-Fan Canisters (Left and Right)
2. Interconnect-Battery Canister (Center)
3. Top of the CE7922 Controller Tray

In the rear are two controller canisters, with controller A on the top and controller B on the bottom. Controller A is upside down, and controller B is right-side up.

CE7922 Controller Tray – Rear View

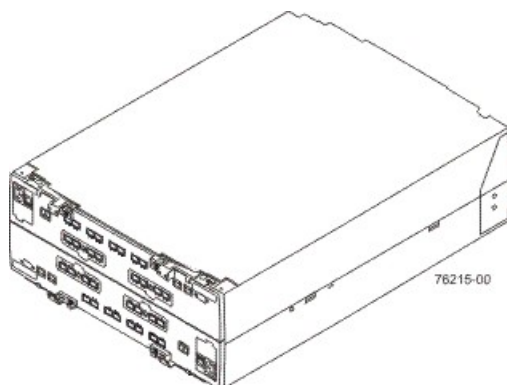

CE7922 Controller Tray Dimensions

The CE7922 controller tray conforms to the 48.3-cm (19-in.) rack standard.

Dimensions of the CE7922 Controller Tray – Front View

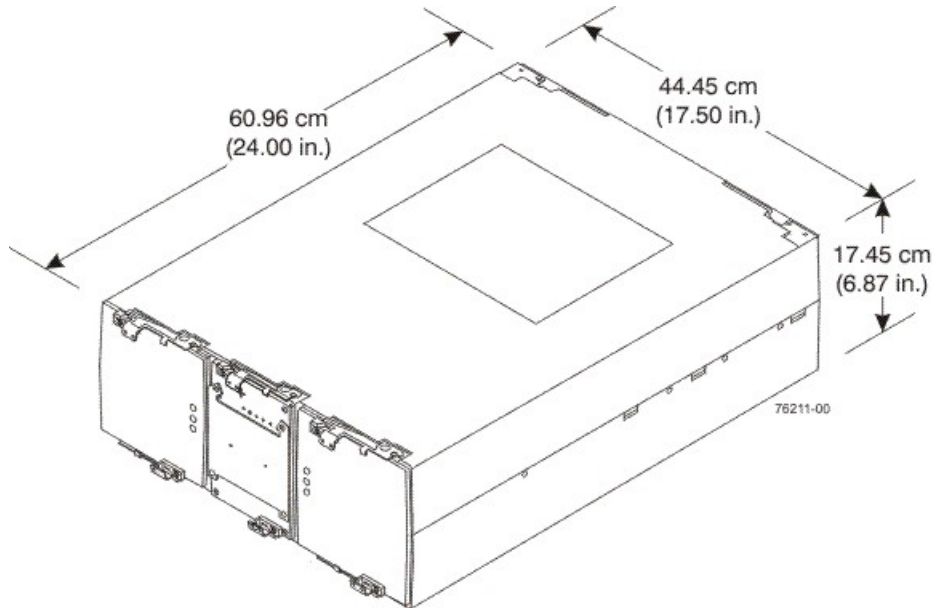

CE7922 Controller Tray Weight

Weights of the CE7922 Controller Tray

| Unit | Weight | | |
|--|--------------------|--------------------|---------------------|
| | Maximum* | Empty** | Shipping*** |
| CE7922 controller tray | 36.79 kg (81.1 lb) | 13.15 kg (29.0 lb) | 49.44 kg (109.0 lb) |
| <p>*Maximum weight indicates a controller tray with all of its components installed. **Empty weight indicates a controller tray with the controller canisters, the power-fan canisters, and the interconnect-battery canister removed. ***Shipping weight indicates the maximum weight of a controller tray and all shipping material.</p> | | | |

Component Weights of the CE7922 Controller Tray

| Component | Weight |
|--|--------------------|
| Controller canister | 6.24 kg (13.8 lb) |
| Power-fan canister | 3.719 kg (8.20 lb) |
| Interconnect-battery canister (with two batteries installed) | 4.082 kg (9.00 lb) |

| Component | Weight |
|------------------|--------------------|
| Battery canister | 1.134 kg (2.50 lb) |

CE7922 Controller Tray Shipping Dimensions

Shipping Carton Dimensions for the CE7922 Controller Tray

| Height | Width | Depth |
|---|----------------------|----------------------|
| 44.45 cm (17.50 in.) – Includes the height of the pallet. | 62.23 cm (24.50 in.) | 78.74 cm (31.00 in.) |

CE7922 Controller Tray Temperature and Humidity

Temperature Requirements and Humidity Requirements for the CE7922 Controller Tray

| Condition | Parameter | Requirement |
|--|------------------------|--------------------------------|
| Temperature* | Operating range | 10°C to 40°C (32°F to 104°F) |
| | Maximum rate of change | 10°C (18°F) per hour |
| | Storage range | –10°C to 65°C (14°F to 149°F) |
| | Maximum rate of change | 15°C (27°F) per hour |
| | Transit range | –40°C to 65°C (–40°F to 149°F) |
| | Maximum rate of change | 20°C (36°F) per hour |
| Relative humidity (no condensation) | Operating range | 20% to 80% |
| | Storage range | 10% to 93% |
| | Transit range | 5% to 95% |
| | Maximum dew point | 26°C (79°F) |
| | Maximum gradient | 10% per hour |
| *If you plan to operate a system at an altitude between 1000 m to 3048 m (3280 ft to 10,000 ft) above sea level, lower the environmental temperature 1.7°C (3.3°F) for every 1000 m (3280 ft) above sea level. | | |

CE7922 Controller Tray Altitude Ranges

Altitude Ranges for the CE7922 Controller Tray

| Environment | Altitude |
|-------------|---|
| Operating | 30.5 m (100 ft) below sea level to 3048 m (10,000 ft) above sea level |
| Storage | 30.5 m (100 ft) below sea level to 3048 m (10,000 ft) above sea level |
| Transit | 30.5 m (100 ft) below sea level to 12,000 m (40,000 ft) above sea level |

CE7922 Controller Tray Airflow and Heat Dissipation

Airflow goes from the front of the controller tray to the rear of the controller tray. Allow at least 76 cm (30 in.) in clearance in front of the controller tray and at least 61 cm (24 in.) in clearance behind the controller tray for service clearance, ventilation, and heat dissipation.

Airflow Through the CE7922 Controller Tray – Front View

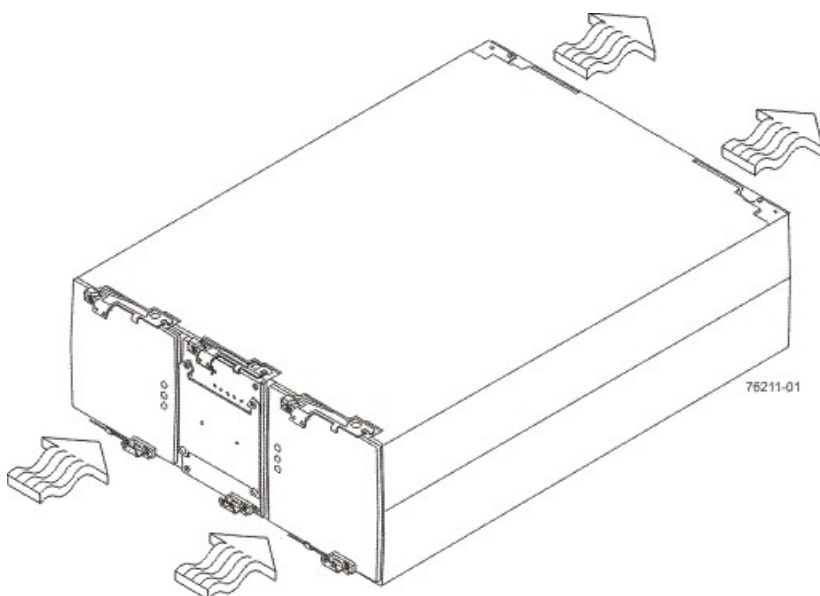

The tabulated power and heat dissipation values in the following table are the maximum measured operating power. Maximum configuration units are typically operated at higher data rates or have larger random access memory (RAM) capabilities.

Power Ratings and Heat Dissipation for the CE7922 Controller Tray

| Component | KVA | Watts (AC) | Btu/Hr | Amps (240 VAC) |
|------------------------|-------|------------|--------|----------------|
| CE7922 controller tray | 0.562 | 540 | 1842 | 2.25 |

CE7922 Controller Tray Acoustic Noise

Sound Levels for the CE7922 Controller Tray

| Measurement | Level |
|----------------|----------|
| Sound power | 6.0 bels |
| Sound pressure | 60 dBA |

CE7922 Controller Tray Site Wiring and Power

The agency ratings for the CE7922 controller tray are 5.40 A at 100 VAC and 2.25 A at 240 VAC. These ratings are the overall maximum currents for this system.

The CE7922 controller tray uses wide-ranging redundant power supplies that automatically accommodate voltages to the AC power source. The power supplies operate within the range of 90 VAC to 264 VAC, at a minimum frequency of 50 Hz and a maximum frequency of 60 Hz. Voltage levels can fluctuate within the specified range. The power supplies meet standard voltage requirements for both North American (USA and Canada) operation and worldwide (except USA and Canada) operation. The power supplies use standard industrial wiring with line-to-neutral or line-to-line power connections.

Consider this information when you prepare the installation site for the controller tray:

- **Protective ground** – Site wiring must include a protective ground connection to the AC power source.



NOTE *Protective ground* is also known as safety ground or chassis ground.

- **Circuit overloading** – Power circuits and associated circuit breakers must provide enough power and overload protection. To prevent damage to the controller tray, isolate its power source from large switching loads, such as air-conditioning motors, elevator motors, and factory loads.
- **Power interruptions** – The controller tray can withstand these applied voltage interruptions:
 - **Input transient** – 50 percent of the nominal voltage
 - **Duration** – One-half cycle
 - **Maximum frequency** – Once every 10 seconds
- **Power failures** – If a total power failure occurs, the controller tray automatically performs a power-on recovery sequence without operator intervention after the power is restored.



NOTE When a power failure occurs, the controller tray uses battery power to back up the data that is in cache.

If you are installing a large storage array configuration, you must make sure that you are supplying the correct AC source voltages and not creating an over-current situation.

When calculating the cabinet's total power requirements, take the controller tray's 540 W, and divide it by the cabinet's input voltage. If you are using 240 VAC, you obtain a maximum current of 2.25 A. Then add the amperage of each drive tray. If each drive tray uses 1.85 A, then 10 drive trays would use 18.5 A. In this example, your total storage array would use a rated maximum of 20.75 A.

CE7922 Controller Tray Power Cords and Receptacles

Each CE7922 controller tray is shipped with two AC power cords. Each AC power cord connects one of the power-fan canisters in the controller tray to an independent, external AC power source, such as a wall receptacle or an uninterruptible power supply (UPS).

AC Power Distribution to a CE7922 Storage Array – Rear View

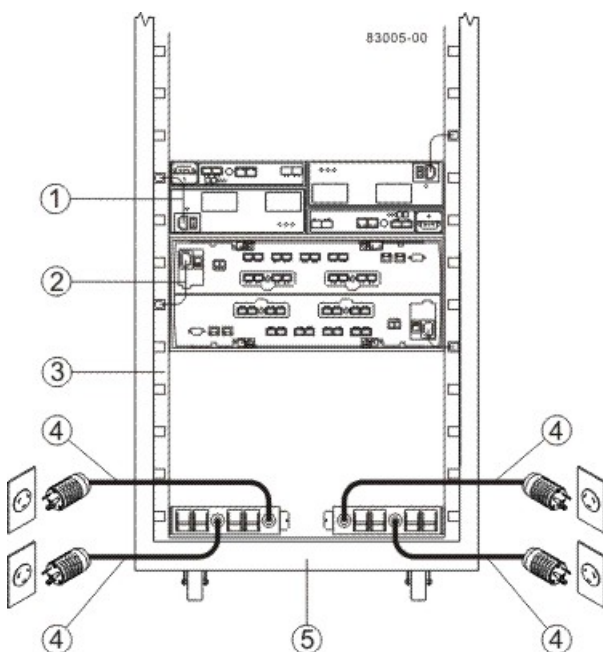

1. AC Power Cord to the Drive Tray
2. AC Power Cord to the CE7922 Controller Tray
3. Power Strip Portion of the Power Distribution Unit
4. AC Power Cord to the External Power Source
5. Rear of the Cabinet

The optional UPS equipment is either placed external from the cabinet, or it is placed at the bottom of the cabinet. UPS devices provide a continuous supply of electrical power when utility power is unavailable. Some UPS equipment can also provide power conditioning to protect your storage array from voltage spikes, line noise, and undesirable power fluctuations, such as brownout. Contact an electrician to help you select and install the correct UPS equipment.

Switched-rack power distribution units (PDUs) are also available for some customer-supplied cabinets. These new PDUs are stand-alone, network-manageable devices that allow programmable control of the power outlets. This capability enables you to control each outlet independently, manage power sequencing, and monitor the aggregate current draw through the switched-rack PDU. Additional equipment may be used to support temperature monitoring as well.

Preparing the Network for the Controllers

If you plan to use Ethernet connections from the storage management station to the controllers, you will use the out-of-band management method. For this configuration, meet with your network administrator before you order and install the equipment so that you can prepare for the setup and management of the devices on the IP network. Each controller uses its Ethernet management ports to connect to the IP network and communicate with the other devices on the IP network (often requiring a special application to set up the protocol).

Your network administrator can pre-assign the addresses that you need to manage the communication between the devices on the IP network. Depending on your storage configuration, you will need the following addresses:

- Up to two network IP addresses for each controller
- Up to two subnet mask addresses for each controller
- Either two IPv4 addresses (one static and one dynamic) or one IPv6 address for each controller
- A Dynamic Host Configuration Protocol (DHCP) address for each controller

If switches are used in your storage environment, you must know if zoning will be used, and how it will be configured.

Specifications of the CE6998 Controller Tray

The CE6998 controller tray is a compact, rackmounted unit that provides high-capacity disk storage for Fibre Channel environments.

The CE6998 controller tray contains two power-fan canisters that include the power supplies and fans. One power-fan canister can provide electrical power and cooling to the controller tray if the other power-fan canister is turned off or malfunctions.

In the front, behind the bezel, are two power-fan canisters and one interconnect-battery canister. In the rear are two controller canisters, with controller A on the top and controller B on the bottom. Controller A is upside down, and controller B is right-side up.

CE6998 Controller Tray – Front View and Rear View

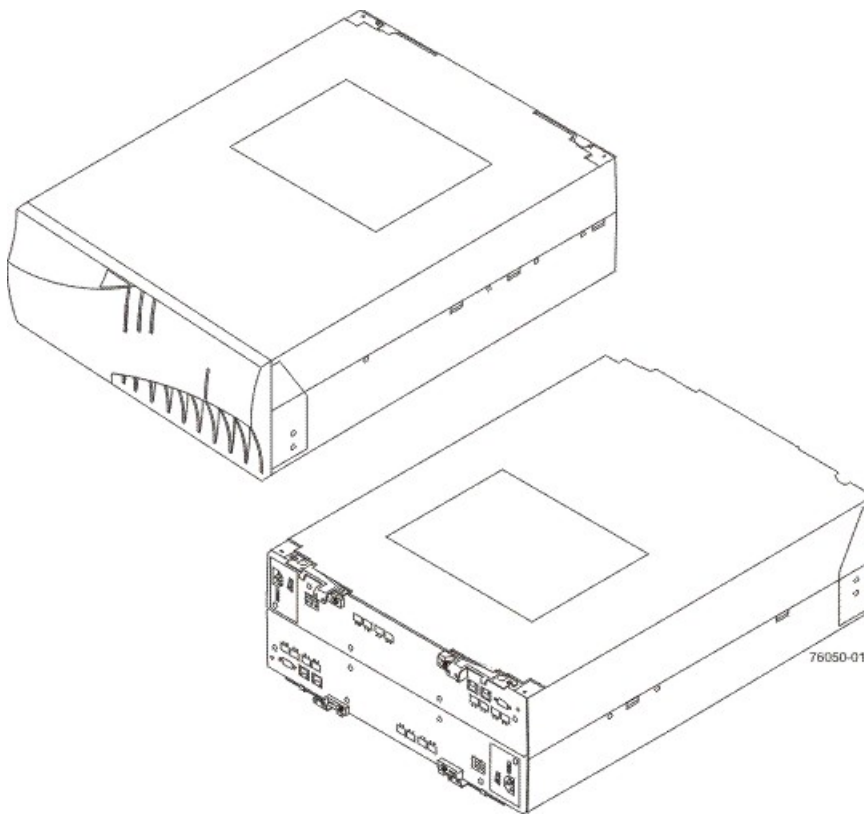

CE6998 Controller Tray Dimensions

The CE6998 controller tray conforms to the 48.3-cm (19-in.) rack standard.

Dimensions of the CE6998 Controller Tray – Front View

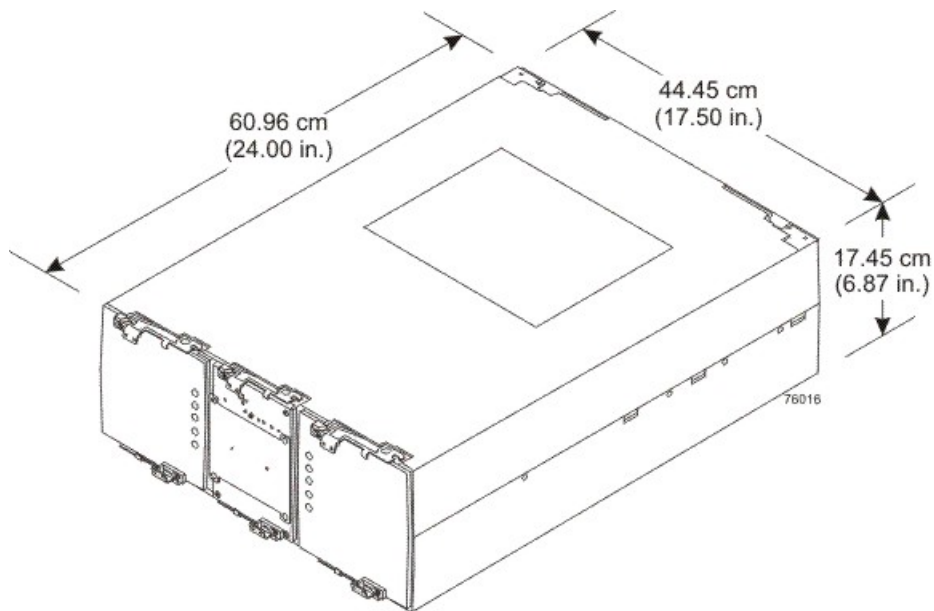

CE6998 Controller Tray Weight

Weights of the CE6998 Controller Tray

| Unit | Weight | | |
|--|--------------------|--------------------|---------------------|
| | Maximum* | Empty** | Shipping*** |
| CE6998 controller tray | 36.79 kg (81.1 lb) | 13.15 kg (29.0 lb) | 49.44 kg (109.0 lb) |
| <p>*Maximum weight indicates a controller tray with all of its components installed. **Empty weight indicates a controller tray with the controller canisters, the power-fan canisters, and the interconnect-battery canister removed. ***Shipping weight indicates the maximum weight of the controller tray and all shipping material.</p> | | | |

Component Weights of the CE6998 Controller Tray

| Component | Weight |
|--|--------------------|
| Controller canister | 6.24 kg (13.8 lb) |
| Power-fan canister | 3.719 kg (8.20 lb) |
| Interconnect-battery canister (with two batteries installed) | 4.082 kg (9.00 lb) |
| Battery canister | 1.134 kg (2.50 lb) |

CE6998 Controller Tray Shipping Dimensions

Shipping Carton Dimensions for the CE6998 Controller Tray

| Height | Width | Depth |
|---|----------------------|----------------------|
| 44.45 cm (17.50 in.) – Includes the height of the pallet. | 62.23 cm (24.50 in.) | 78.74 cm (31.00 in.) |

CE6998 Controller Tray Temperature and Humidity

Temperature Requirements and Humidity Requirements for the CE6998 Controller Tray

| Condition | Parameter | Requirement |
|--|------------------------|--------------------------------|
| Temperature* | Operating range | 0°C to 40°C (32°F to 104°F) |
| | Maximum rate of change | 10°C (18°F) per hour |
| | Storage range | -10°C to 65°C (14°F to 149°F) |
| | Maximum rate of change | 15°C (27°F) per hour |
| | Transit range | -40°C to 65°C (-40°F to 149°F) |
| | Maximum rate of change | 20°C (36°F) per hour |
| Relative humidity (no condensation) | Operating range | 20% to 80% |
| | Storage range | 10% to 93% |
| | Transit range | 5% to 95% |
| | Maximum dew point | 26°C (79°F) |
| | Maximum gradient | 10% per hour |
| *If you plan to operate a system at an altitude between 1000 m to 3048 m (3280 ft to 10,000 ft) above sea level, lower the environmental temperature 1.7°C (3.3°F) for every 1000 m (3280 ft) above sea level. | | |

CE6998 Controller Tray Altitude Ranges

Altitude Ranges for the CE6998 Controller Tray

| Environment | Altitude |
|-------------|---|
| Operating | 30.5 m (100 ft) below sea level to 3048 m (10,000 ft) above sea level |
| Storage | 30.5 m (100 ft) below sea level to 3048 m (10,000 ft) above sea level |

| Environment | Altitude |
|-------------|---|
| Transit | 30.5 m (100 ft) below sea level to 12,000 m (40,000 ft) above sea level |

CE6998 Controller Tray Airflow and Heat Dissipation

Airflow goes from the front of the controller tray to the rear of the controller tray. Allow at least 76 cm (30 in.) of clearance in front of the controller tray and at least 61 cm (24 in.) of clearance behind the controller tray for service clearance, ventilation, and heat dissipation.

Airflow Through the CE6998 Controller Tray – Front View

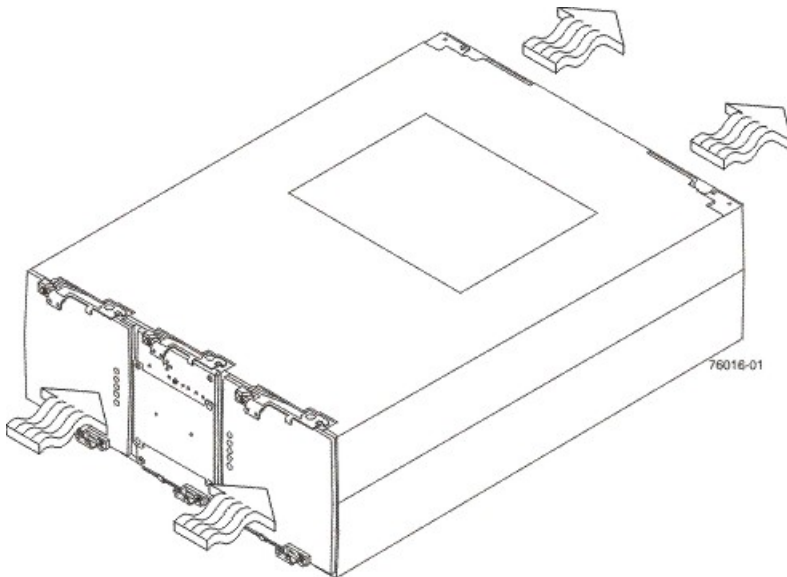

The tabulated power and heat dissipation values in the following table are the maximum measured operating power. Maximum configuration units are typically operated at higher data rates or have larger random access memory (RAM) capabilities.

Power Ratings and Heat Dissipation for the CE6998 Controller Tray

| Component | KVA | Watts (AC) | Btu/Hr | Amps (240 VAC) |
|------------------------|-------|------------|--------|----------------|
| CE6998 controller tray | 0.546 | 525 | 1791 | 2.19 |

CE6998 Controller Tray Acoustic Noise

Sound Levels for the CE6998 Controller Tray

| Measurement | Level |
|----------------|----------|
| Sound power | 6.0 bels |
| Sound pressure | 60 dBA |

CE6998 Controller Tray Site Wiring and Power

The agency ratings for the CE6998 controller tray are 5.25 A at 100 VAC and 2.19 A at 240 VAC. These ratings are the overall maximum currents for this system.

The CE6998 controller tray uses wide-ranging redundant power supplies that automatically accommodate voltages to the AC power source. The power supplies operate within the range of 90 VAC to 264 VAC, at a minimum frequency of 50 Hz and a maximum frequency of 60 Hz. Voltage levels can fluctuate within the specified range. The power supplies meet standard voltage requirements for both North American (USA and Canada) operation and worldwide (except USA and Canada) operation. The power supplies use standard industrial wiring with line-to-neutral or line-to-line power connections.

Keep this information in mind when you prepare the installation site for the controller tray:

- **Protective ground** – Site wiring must include a protective ground connection to the AC power source.



NOTE *Protective ground* is also known as safety ground or chassis ground.

- **Circuit overloading** – Power circuits and associated circuit breakers must provide enough power and overload protection. To prevent damage to the controller tray, isolate its power source from large switching loads, such as air-conditioning motors, elevator motors, and factory loads.
- **Power interruptions** – The controller tray can withstand these applied voltage interruptions:
 - **Input transient** – 50 percent of the nominal voltage
 - **Duration** – One-half cycle
 - **Maximum frequency** – Once every 10 seconds
- **Power failures** – If a total power failure occurs, the controller tray automatically performs a power-on recovery sequence without operator intervention after the power is restored.



NOTE When a power failure occurs, the controller tray uses battery power to back up the data that is in cache.

If you are installing a large storage array configuration, you must make sure that you are supplying the correct AC source voltages, and not creating an over-current situation.

When calculating the cabinet's total power requirements, take the controller tray's 525 W, and divide it by the cabinet's input voltage. If you are using 240 VAC, you obtain a maximum current of 2.19 A. Then add the amperage of each drive tray. If each drive tray uses 1.85 A, then 10 drive trays would use 18.5 A. In this example, your total storage array would use a rated maximum of 20.69 A.

CE6998 Controller Tray Power Cords and Receptacles

Each CE6998 controller tray is shipped with two AC power cords. Each AC power cord connects one of the power-fan canisters in the controller tray to an independent, external AC power source, such as a wall receptacle, or to any uninterruptible power supply (UPS).

The optional UPS equipment is either placed external from the cabinet, or it is placed at the bottom of the cabinet. UPS devices provide a continuous supply of electrical power when utility power is unavailable. Some UPS equipment can also provide power conditioning to protect your storage array from voltage spikes, line noise, and undesirable power fluctuations, such as brownout. Contact an electrician to help you select and install the correct UPS equipment.

Switched-rack PDUs are also available for some customer-supplied cabinets. These new PDUs are stand-alone, network-manageable devices that allow programmable control of the power outlets. This capability enables you to control each outlet independently, manage power sequencing, and monitor the aggregate current draw through the switched-rack PDU. Additional equipment may be used to support temperature monitoring as well.

Preparing the Network for the Controllers

If you plan to use Ethernet connections from the storage management station to the controllers, you will use the out-of-band management method. For this configuration, meet with your network administrator before you order and install the equipment so that you can prepare for the setup and management of the devices on the IP network. Each controller uses its Ethernet management ports to connect to the IP network and communicate with the other devices on the IP network (often requiring a special application to set up the protocol).

Your network administrator can pre-assign the addresses that you need to manage the communication between the devices on the IP network. Depending on your storage configuration, you will need the following addresses:

- Up to two network IP addresses for each controller
- Up to two subnet mask addresses for each controller
- Either two IPv4 addresses (one static and one dynamic) or one IPv6 address for each controller
- A Dynamic Host Configuration Protocol (DHCP) address for each controller

If switches are used in your storage environment, you must know if zoning will be used, and how it will be configured.

Specifications of the CE2600 Controller-Drive Tray

The CE2600 controller-drive tray is available in a rackmount model, with a capacity of either 12 drives or 24 drives.

CE2600 Controller-Drive Tray with 12 Drives – Front View

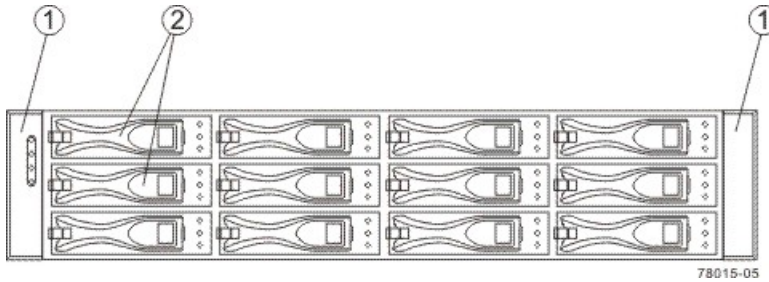

1. End Caps (the Left End Cap Has the Controller-Drive Tray Summary LEDs)
2. Drive Canisters

CE2600 Controller-Drive Tray with 24 Drives – Front View

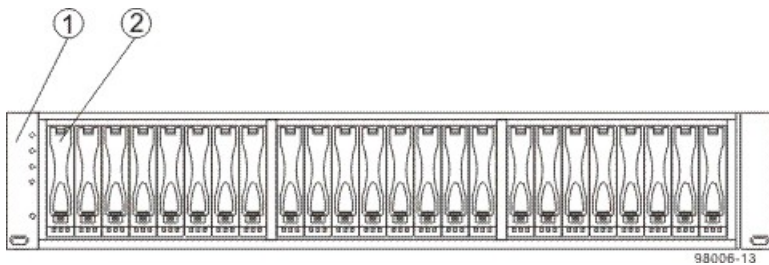

1. End Caps (the Left End Cap Has the Controller-Drive Tray Summary LEDs)
2. Drive Canisters

CE2600 Controller-Drive Tray Duplex Configuration – Rear View

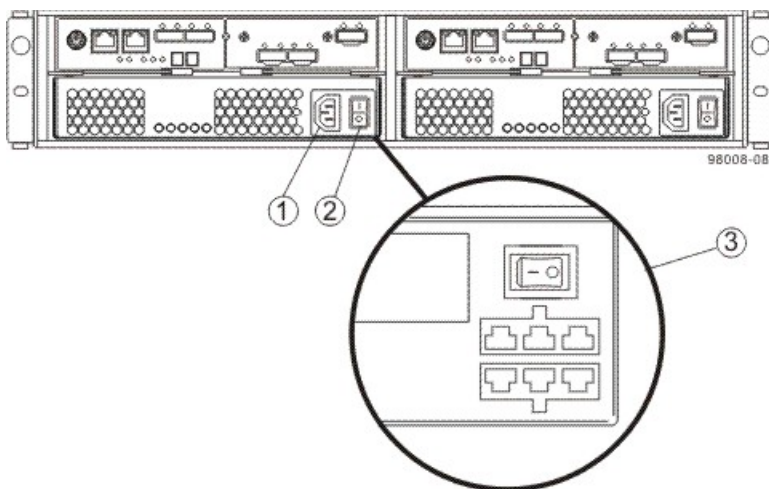

1. AC Power Connector on the AC Power-Fan Canister
2. AC Power Switch
3. DC Power Connector and DC Power Switch on the Optional DC Power-Fan Canister

CE2600 Controller-Drive Tray Simplex Configuration – Rear View

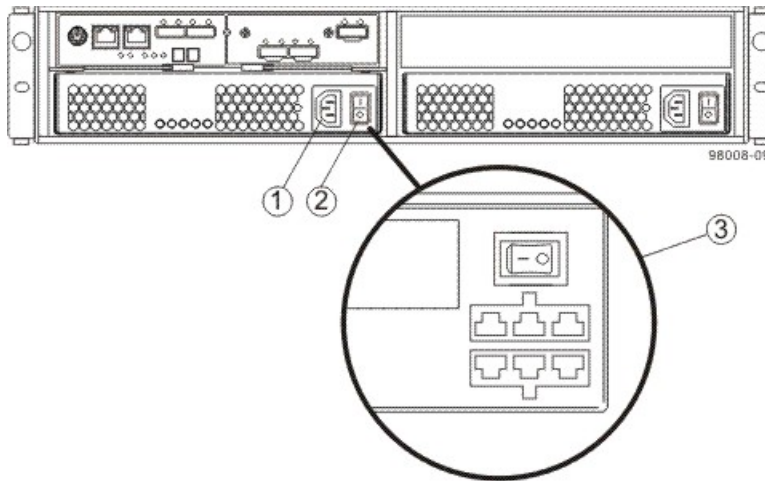

1. AC Power Connector
2. AC Power Switch
3. Optional DC Power Connector and DC Power Switch

CE2600 Controller-Drive Tray Dimensions

The CE2600 controller-drive tray conforms to the 48.3-cm (19.0-in.) rack standard.

Dimensions of the CE2600 Controller-Drive Tray (12-Drive Model) – Front View

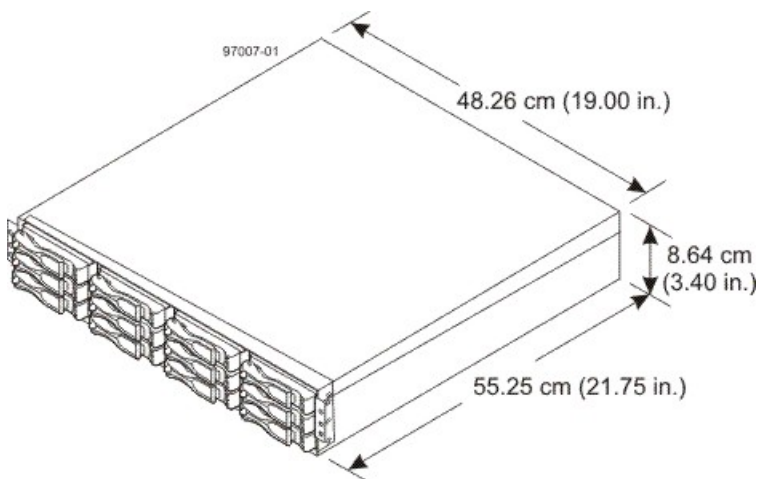

Dimensions of the CE2600 Controller-Drive Tray (24-Drive Model) – Front View

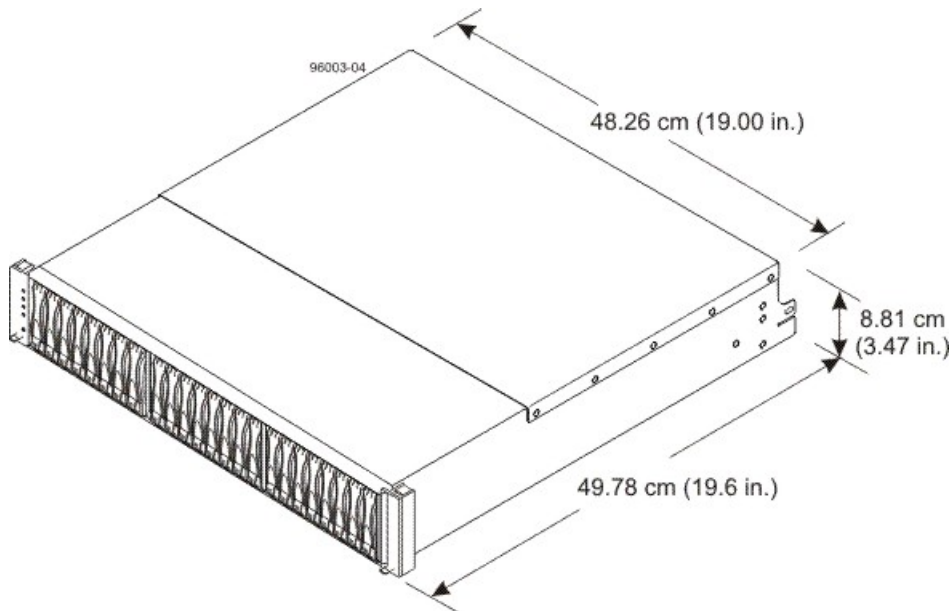

CE2600 Controller-Drive Tray Weight

Weights of the CE2600 Controller-Drive Tray

| Unit | Weight | | |
|--|------------------|---------------------|--------------------|
| | Maximum* | Empty** | Shipping*** |
| Controller-Drive Tray, with twelve 8.89-cm (3.5-in.) drives | 27 kg (59.52 lb) | 18.60 kg (41.01 lb) | 31.75 kg (70.0 lb) |
| Controller-Drive Tray, with twenty-four 6.35-cm (2.5-in.) drives | 26 kg (57.32 lb) | 21.70 kg (47.84 lb) | 31.75 kg (70.0 lb) |

*Maximum weight indicates a controller-drive tray with all of its drives and other components installed. Because drive weights can vary greatly, this value can vary from the value specified as much as either 0.3 kg (0.66 lb) times the maximum number of drives per controller-drive tray for 3.5-in. SATA drives or 0.08 kg (0.18 lb) times the maximum number of drives per controller-drive tray for 2.5-in. SATA drives.

**Empty weight indicates a controller-drive tray with the controller canisters, the power-fan canisters, and the drives removed.

***Shipping weight indicates the maximum weight of the controller-drive tray and all shipping material.

| Component | Weight |
|---------------------|--------------------|
| Controller canister | 2.131 kg (4.70 lb) |
| Power-fan canister | 2.500 kg (5.51 lb) |
| 2.5-in. SATA drive | 0.3 kg (0.66 lb) |

| Component | Weight |
|--------------------|-----------------|
| 3.5-in. SATA drive | 1.0 kg (2.2 lb) |

CE2600 Controller-Drive Tray Shipping Dimensions

Shipping Carton Dimensions for the CE2600 Controller-Drive Tray

| Height | Width | Depth |
|--|-------------------|-------------------|
| 24.13 cm (9.5 in.)* | 63.50 cm (25 in.) | 58.42 cm (23 in.) |
| 24.13 cm (9.5 in.)** | 68.58 cm (27 in.) | 58.42 cm (23 in.) |
| *Controller-Drive Tray with twelve 3.5-in. drives. **Controller-Drive Tray with twenty-four 2.5-in. drives. | | |

CE2600 Controller-Drive Tray Temperature and Humidity

Temperature Requirements and Humidity Requirements for the CE2600 Controller-Drive Tray

| Condition | Parameter | Requirement |
|-------------------------------------|--|--------------------------------|
| Temperature | Operating range (both cabinet and subsystem) | 10°C to 35°C (50°F to 104°F) |
| | Maximum rate of change | 10°C (50°F) per hour |
| | Storage range | -10°C to 50°C (14°F to 122°F) |
| | Maximum rate of change | 15°C (59°F) per hour |
| | Transit range | -40°C to 60°C (-40°F to 140°F) |
| | Maximum rate of change | 20°C (68°F) per hour |
| Relative humidity (no condensation) | Operating range (both cabinet and subsystem) | 20% to 80% |
| | Storage range | 10% to 90% |
| | Transit range | 5% to 90% |
| | Operating gradient | 10°C (50°F) per hour maximum |
| | Storage gradient | 15°C (59°F) per hour maximum |
| | Transit gradient | 20°C (68°F) per hour maximum |

| Condition | Parameter | Requirement |
|--|-------------------|--------------|
| | Maximum dew point | 26°C (79°F) |
| | Maximum gradient | 10% per hour |
| *If you plan to operate a system at an altitude between 1000 m to 3000 m (3280 ft to 9842 ft) above sea level, lower the environmental temperature 1.7°C (3.3°F) for every 1000 m (3280 ft) above sea level. | | |

CE2600 Controller-Drive Tray Altitude Ranges

Altitude Ranges for the CE2600 Controller-Drive Tray

| Environment | Altitude |
|-------------|---|
| Operating | 30.5 m (100 ft) below sea level to 3000 m (9840 ft) above sea level |
| Storage | 30.5 m (100 ft) below sea level to 3000 m (9840 ft) above sea level |
| Transit | 30.5 m (100 ft) below sea level to 12,000 m (40,000 ft) above sea level |

CE2600 Controller-Drive Tray Airflow and Heat Dissipation

Allow at least 76 cm (30 in.) of clearance in front of the controller-drive tray and 61 cm (24 in.) behind the controller-drive tray for service clearance, ventilation, and heat dissipation.

Airflow Through the Controller-Drive Tray with 12 Drives – Front View

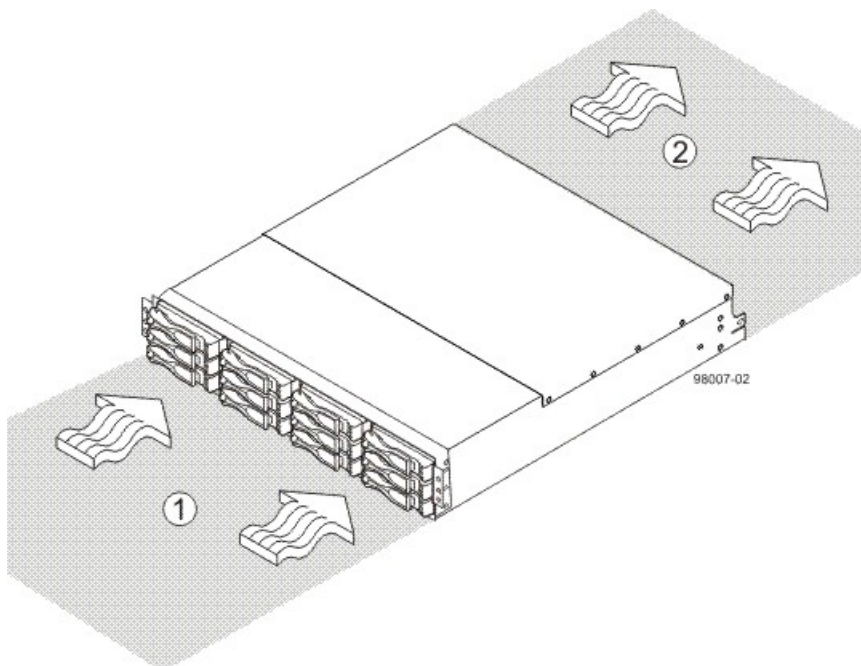

1. 76 cm (30 in.) clearance in front of the cabinet
2. 61 cm (24 in.) clearance behind the cabinet

Airflow Through the Controller-Drive Tray with 24 Drives – Front View

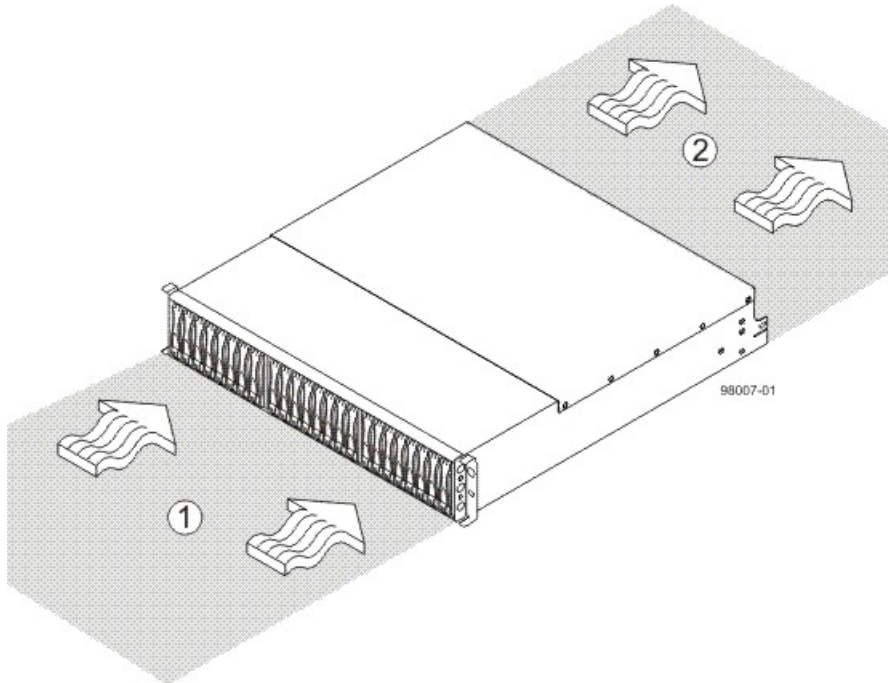

1. 76 cm (30 in.) clearance in front of the cabinet
2. 61 cm (24 in.) clearance behind the cabinet

Power and Heat Dissipation for the CE2600 Controller-Drive Tray

| Component | KVA | Watts (AC) | Btu/Hr |
|---|-------|------------|--------|
| Controller canisters with two power-fan canisters and 12 drives | 0.400 | 399 | 1366 |
| Controller canisters with two power-fan canisters and 24 drives | 0.331 | 330 | 1127 |

CE2600 Controller-Drive Tray Acoustic Noise

Acoustic Noise at 25°C for the CE2600 Controller-Drive Tray

| Measurement | Level |
|-----------------------------------|------------------|
| Sound power (standby operation) | 6.5 bels maximum |
| Sound pressure (normal operation) | 65 dBA maximum |

CE2600 Controller-Drive Tray Site Wiring and Power

The CE2600 controller-drive tray uses wide-ranging, redundant power supplies that automatically accommodate voltages to the AC power source or the optional –48-VDC power source. The power supplies meet standard voltage requirements for both North American (USA and Canada) operation and worldwide (except USA and Canada) operation. The power supplies use standard industrial wiring with line-to-neutral or line-to-line power connections.

 **NOTE** Power for the optional –48-VDC power configuration is supplied by a centralized DC power plant instead of the AC power source in the cabinet. Refer to the associated manufacturer's documentation for specific DC power source requirements.

Keep this information in mind when you prepare the installation site for the controller-drive tray:

- **Protective ground** – Site wiring must include a protective ground connection to the AC power source or the optional –48-VDC power source.

 **NOTE** *Protective ground* is also known as safety ground or chassis ground.

- **Circuit overloading** – Power circuits and associated circuit breakers must provide enough power and overload protection. To prevent damage to the controller-drive tray, isolate its power source from large switching loads, such as air-conditioning motors, elevator motors, and factory loads.
- **Power interruptions** – The controller-drive tray can withstand these applied voltage interruptions:
 - **Input transient** – 50 percent of the nominal voltage
 - **Duration** – One-half cycle
 - **Frequency** – Once every 10 seconds
- **Power failures** – If a total power failure occurs, the controller-drive tray automatically performs a power-on recovery sequence without operator intervention.

CE2600 Controller-Drive Tray Power Input

AC Power Input

Each power supply contains one 10-A slow-blow fuse.

AC Power Requirements for the CE2600 Controller-Drive Tray

| Parameter | Low Range | High Range |
|--------------------------------|-------------|-------------|
| Nominal voltage | 100 VAC | 240 VAC |
| Frequency | 50 to 60 Hz | 50 to 60 Hz |
| Idle current | 3.97 A* | 1.63 A** |
| Maximum operating current | 4.25 A* | 1.68 A** |
| Sequential Drive Group Spin Up | 4.27 A | 1.76 A |
| Simultaneous Drive Spin Up | 6.13 A | 2.71 A |
| System Rating Plate Label | 7.0 A | 2.9 A |

| Parameter | Low Range | High Range |
|---|-----------|------------|
| <p>* Typical current: 100 VAC, 60 Hz at 0.87 power supply efficiency and 0.99 power factor. These numbers can vary significantly, depending upon the drives tested in the particular configuration.</p> <p>**Typical current: 240 VAC, 60 Hz at 0.87 power supply efficiency and 0.99 power factor. These numbers can vary significantly, depending upon the drives tested in the particular configuration.</p> | | |

DC Power Input

Nominal input voltages for the DC power source are as follows:

- Low range: –42 VDC
- High range: –60 VDC

The maximum operating current is 21.7 A.

CE2600 Controller-Drive Tray Power Factor Correction

Power factor correction is applied within the power supply, which maintains the power factor of the controller-drive tray at greater than 0.95 with nominal input voltage.

CE2600 Controller-Drive Tray AC Power Cords and Receptacles

Each CE2600 controller-drive tray is shipped with two AC power cords. Each AC power cord connects one of the power supplies in a controller-drive tray to an independent, external AC power source, such as a wall receptacle or a UPS.

If you have a cabinet with internal power cabling, such as a ladder cord, you do not need the AC power cords that are shipped with the controller-drive tray.

DC power is an option that is available for use with your controller-drive tray and drive trays. For more information, see [CE2600 Controller-Drive Tray Optional DC Power Connector Cables and Source Wires](#).

CE2600 Controller-Drive Tray Optional DC Power Connector Cables and Source Wires

The CE2600 controller-drive tray is shipped with –48-VDC power connector cables if the DC power option is ordered. The –48-VDC power connector cable plugs into the DC power connector on the rear of the controller-drive tray. The three source wires on the other end of the power connector cable connect the controller-drive tray to centralized DC power plant equipment, typically through a bus bar above the cabinet.



WARNING (W12) Risk of electrical shock – This unit has more than one power source. To remove all power from the unit, all DC MAINS must be disconnected by removing all power connectors (item 4 below) from the power supplies.

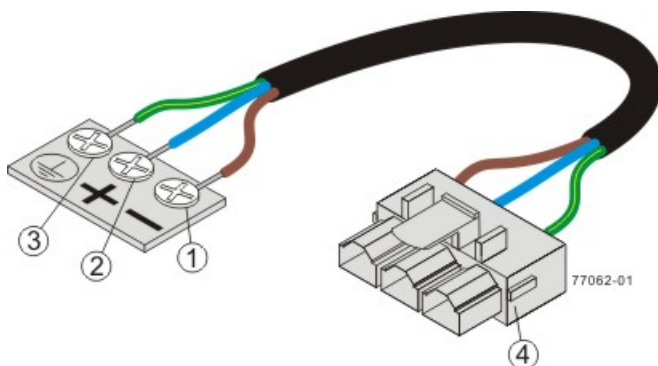

1. Supply (Negative), Brown Wire, -48 VDC
2. Return (Positive), Blue Wire
3. Ground, Green and Yellow Wire
4. DC Power Connector



WARNING (W14) Risk of bodily injury – A qualified service person is required to make the DC power connection according to NEC and CEC guidelines.

Two (or, optionally, four) DC power connector cables are provided with each controller-drive tray. Two DC power connectors are on the two DC power supplies on the rear of each controller-drive tray if additional redundancy is required.



NOTE It is not mandatory that you connect the second DC power connection on the DC power supplies of the controller-drive tray. The second DC power connection is provided for additional redundancy only and can be connected to a second DC power bus.

Preparing the Network for the Controllers

If you plan to use Ethernet connections from the storage management station to the controllers, you will use the out-of-band management method. For this configuration, meet with your network administrator before you order and install the equipment so that you can prepare for the setup and management of the devices on the IP network. Each controller uses its Ethernet management ports to connect to the IP network and communicate with the other devices on the IP network (often requiring a special application to set up the protocol).

Your network administrator can pre-assign the addresses that you need to manage the communication between the devices on the IP network. Depending on your storage configuration, you will need the following addresses:

- Up to two network IP addresses for each controller
- Up to two subnet mask addresses for each controller
- Either two IPv4 addresses (one static and one dynamic) or one IPv6 address for each controller
- A Dynamic Host Configuration Protocol (DHCP) address for each controller

If switches are used in your storage environment, you must know if zoning will be used, and how it will be configured.

Specifications of the CE2600-60 Controller-Drive Tray

The CE2600-60 controller-drive tray is a high-density SAS 2.0 (6-Gb/s) drive enclosure with 60 near-line 3.5" SAS drives, housed in five drawers with 12 drives each.

CE2600-60 Controller-Drive Tray – Front View with Bezel Removed

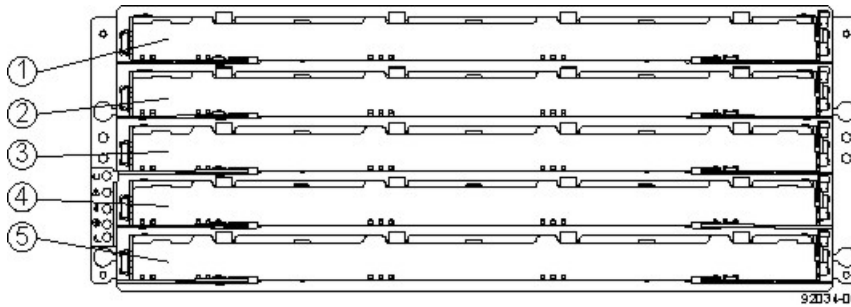

1. Drive Drawer 1
2. Drive Drawer 2
3. Drive Drawer 3
4. Drive Drawer 4
5. Drive Drawer 5

CE2600-60 Controller-Drive Tray – Rear View

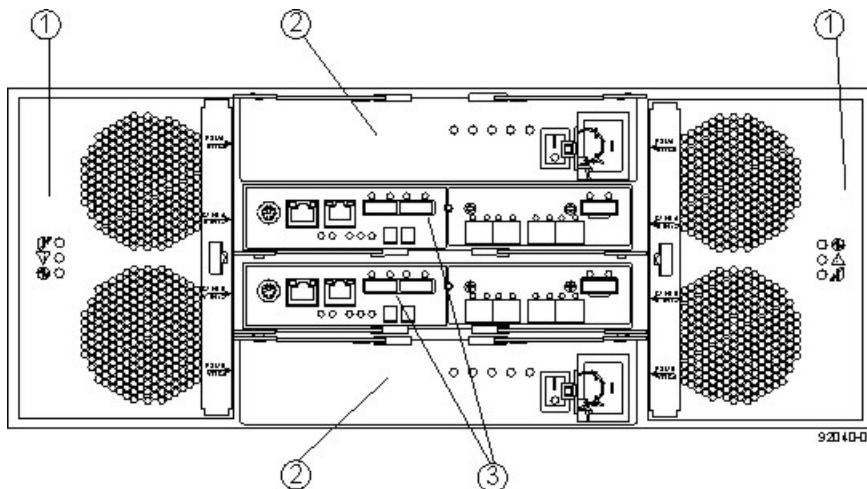

1. Fan Canisters
2. Power Canisters
3. Controller-Drive Tray Canisters

CE2600-60 Controller-Drive Tray Dimensions

The CE2600-60 controller-drive tray conforms to the 48.3-cm (19.0-in.) rack standard.

Dimensions of the CE2600-60 Controller-Drive Tray – Front View

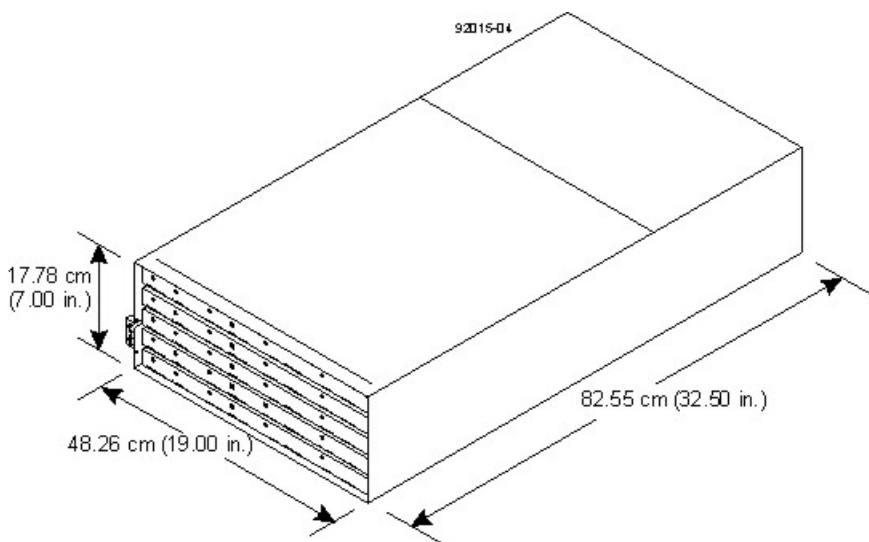

CE2600-60 Controller-Drive Tray Weight

Weights of the CE2600-60 Controller-Drive Tray

| Unit | Weight | | |
|---------------------------------|-------------------|------------------|-------------------|
| | Maximum* | Empty** | Shipping*** |
| CE2600-60 controller-drive tray | 105.2 kg (232 lb) | 59.8 kg (132 lb) | 193.2 kg (426 lb) |

*Maximum weight indicates a controller-drive tray with all of its drives and other components installed. Because drive weights can vary greatly, this value can vary from the value specified as much as 0.3 kg (0.6 lb) times the maximum number of drives per drive tray for drives weighing 0.725 kg (1.6 lb).

**Empty weight indicates a drive tray without the controller canisters, the power canisters, the fan canisters, and the drives.

***Shipping weight indicates the empty weight of a drive tray and all shipping material, as well as the weight of the 60 drives that are shipped separately in multipack cartons.

Component Weights of the CE2600-60 Controller-Drive Tray

| Component | Weight |
|---------------------|------------------------------|
| Controller canister | 2.99 kg (6.60 lb) |
| Power canister | 2.5 kg (5.5 lb) |
| Fan canister | Approximately 1 kg (2.16 lb) |
| Drive | 0.74 kg (1.64 lb) |

CE2600-60 Controller-Drive Tray Shipping Dimensions

Shipping Carton Dimensions for the CE2600-60 Controller-Drive Tray

| Height | Width | Depth |
|-------------------|----------------------|-----------------------|
| 48.26 cm (19 in.) | 60.96 cm (24.00 in.) | 100.97 cm (39.75 in.) |

CE2600-60 Controller-Drive Tray Temperature and Humidity

Temperature Requirements and Humidity Requirements for the CE2600-60 Controller-Drive Tray

| Condition | Parameter | Requirement |
|---|--|--------------------------------|
| Temperature | Operating range (both cabinet and subsystem) | 10°C to 35°C (50°F to 104°F) |
| | Maximum rate of change | 10°C (50°F) per hour |
| | Storage range | -10°C to 50°C (14°F to 122°F) |
| | Maximum rate of change | 15°C (59°F) per hour |
| | Transit range | -40°C to 60°C (-40°F to 140°F) |
| | Maximum rate of change | 20°C (68°F) per hour |
| Relative humidity (no condensation) | Operating range (both cabinet and subsystem) | 20% to 80% |
| | Storage range | 10% to 90% |
| | Transit range | 5% to 90% |
| | Operating gradient | 10°C (50°F) per hour maximum |
| | Storage gradient | 15°C (59°F) per hour maximum |
| | Transit gradient | 20°C (68°F) per hour maximum |
| | Maximum dew point | 26°C (79°F) |
| | Maximum gradient | 10% per hour |
| If you plan to operate a system at an altitude between 1000 m to 3000 m (3280 ft to 9842 ft) above sea level, lower the environmental temperature 1.7°C (3.3°F) for every 1000 m (3280 ft) above sea level. | | |

CE2600-60 Controller-Drive Tray Altitude Ranges

Altitude Ranges for the CE2600-60 Controller-Drive Tray

| Environment | Altitude |
|-------------|---|
| Operating | 30.5 m (100 ft) below sea level to 3000 m (9842 ft) above sea level |
| Storage | 30.5 m (100 ft) below sea level to 3000 m (9842 ft) above sea level |
| Transit | 30.5 m (100 ft) below sea level to 12,000 m (40,000 ft) above sea level |

CE2600-60 Controller-Drive Tray Airflow and Heat Dissipation

Airflow goes from the front of the CE2600-60 controller-drive tray to the rear of the controller-drive tray. Allow at least 81 cm (32 in.) of clearance in front of the CE2600-60 controller-drive tray and at least 61 cm (24 in.) of clearance behind the controller-drive tray for service clearance, ventilation, and heat dissipation.

Airflow Through the CE2600-60 Controller-Drive Tray – Front View

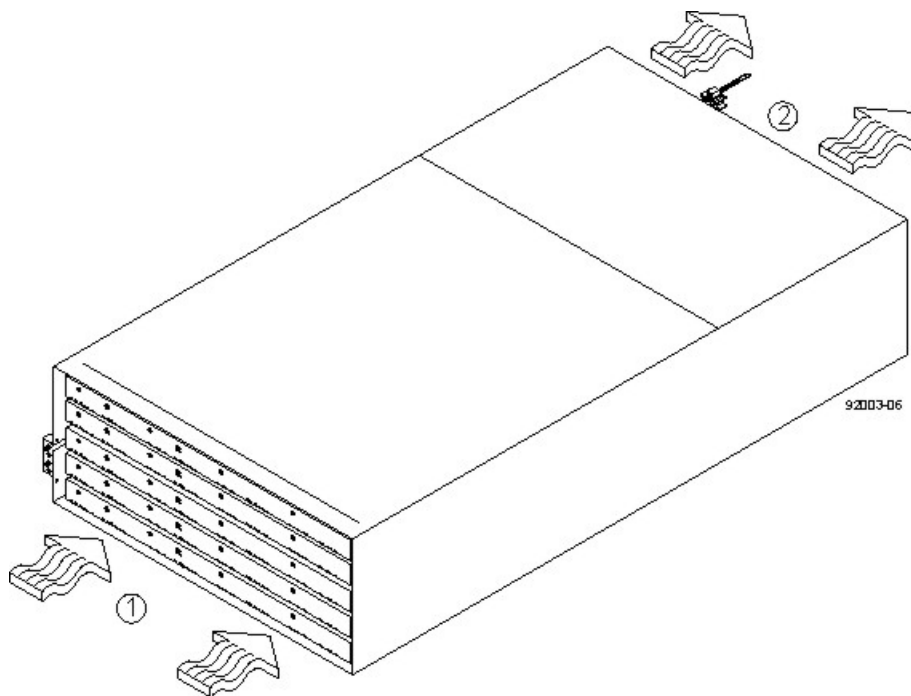

1. 81 cm (32 in.) clearance in front of the cabinet
2. 61 cm (24 in.) clearance behind the cabinet

The tabulated power and heat dissipation values in the following table are the maximum measured operating power.

Power Ratings and Heat Dissipation for the CE2600-60 Controller-Drive Tray

| Unit | KVA | Watts (AC) | Btu/hr |
|--|-------|------------|--------|
| CE2600-60 controller-drive tray with two power supplies, two controller trays, 60 drives (Seagate 2000-Gb SAS drives and controllers), and two fan canisters, full speed | 1.268 | 1222 | 4180 |

CE2600-60 Controller-Drive Tray Acoustic Noise

Acoustic Noise at 25°C for the CE2600-60 Controller-Drive Tray

| Measurement | Level |
|---------------------------------|----------|
| Sound power (standby operation) | 6.5 bels |
| Sound power (normal operation) | 6.8 bels |
| Sound pressure | 68 dBA |

CE2600-60 Controller-Drive Tray Site Wiring and Power

The CE2600-60 controller-drive tray uses wide-ranging, redundant power supplies that automatically accommodate voltages to the AC power source. The power supplies meet standard voltage requirements for both North American (USA and Canada) operation and worldwide (except USA and Canada) operation. The power supplies use standard industrial wiring with line-to-neutral power connections or line-to-line power connections.

Keep this information in mind when you prepare the installation site for the controller-drive tray:

- **Protective ground** – Site wiring must include a protective ground connection to the AC power source.



NOTE *Protective ground* is also known as safety ground or chassis ground.

- **Circuit overloading** – Power circuits and associated circuit breakers must provide enough power and overload protection. To prevent damage to the drive tray, isolate its power source from large switching loads, such as air-conditioning motors, elevator motors, and factory loads.
- **Power interruptions** – The controller-drive tray can withstand these applied voltage interruptions:
 - **Input transient** – 50 percent of the nominal voltage
 - **Duration** – One-half cycle
 - **Frequency** – Once every 10 seconds
- **Power failures** – If a total power failure occurs, the drive tray automatically performs a power-on recovery sequence without operator intervention after the power is restored.

CE2600-60 Controller-Drive Tray Power Input

Each power supply contains one 15-A slow-blow fuse.

AC Power Requirements for the CE2600-60 Controller-Drive Tray

| Parameter | Low Range | High Range |
|---------------------------|-----------|------------|
| Nominal voltage | 200 VAC | 240 VAC |
| Frequency | 50 Hz | 60 Hz |
| Idle current | 5.1 A | 6.0 A |
| Maximum operating current | 6.3 A | 7.56 A |

CE2600-60 Controller-Drive Tray Power Factor Correction

Power factor correction is applied within the power supply, which maintains the power factor of the CE2600-60 controller-drive tray at greater than 0.95 with nominal input voltage.

CE2600-60 Controller-Drive Tray AC Power Cords and Receptacles

Each CE2600-60 controller-drive tray is shipped with two AC power cords, which fit the standard AC outlets in the destination country. Each AC power cord connects one of the power canisters in the drive tray to an independent, external AC power source, such as a wall receptacle, or to any uninterruptible power supply (UPS).



NOTE Possible risk of equipment failure – To ensure proper cooling, the CE2600-60 controller-drive tray always uses two power supplies.

Preparing the Network for the Controllers

If you plan to use Ethernet connections from the storage management station to the controllers, you will use the out-of-band management method. For this configuration, meet with your network administrator before you order and install the equipment so that you can prepare for the setup and management of the devices on the IP network. Each controller uses its Ethernet management ports to connect to the IP network and communicate with the other devices on the IP network (often requiring a special application to set up the protocol).

Your network administrator can pre-assign the addresses that you need to manage the communication between the devices on the IP network. Depending on your storage configuration, you will need the following addresses:

- Up to two network IP addresses for each controller
- Up to two subnet mask addresses for each controller
- Either two IPv4 addresses (one static and one dynamic) or one IPv6 address for each controller
- A Dynamic Host Configuration Protocol (DHCP) address for each controller

If switches are used in your storage environment, you must know if zoning will be used, and how it will be configured.

Specifications of the CE5400 Controller-Drive Tray

The CE5400 controller-drive tray is available in a rackmount model, with a capacity of either 12 drives or 24 drives. The CE5400 controller-drive tray is a compact, rackmounted unit that provides high-capacity disk storage for Fibre Channel, Infiniband, and iSCSI environments, depending on the choice of the host interface card.

CE5400 Controller-Drive Tray with 12 Drives – Front View

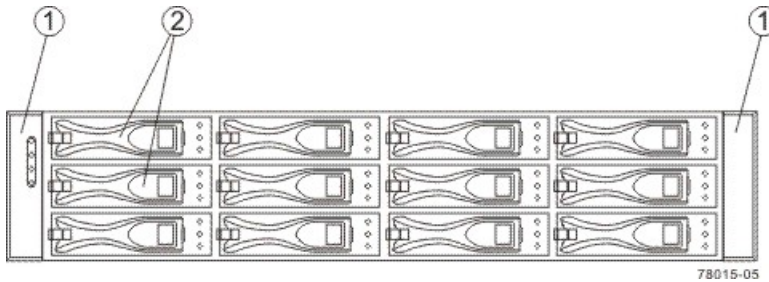

1. End Caps (the Left End Cap Has the Controller-Drive Tray Summary LEDs)
2. Drive Canisters

CE5400 Controller-Drive Tray with 24 Drives – Front View

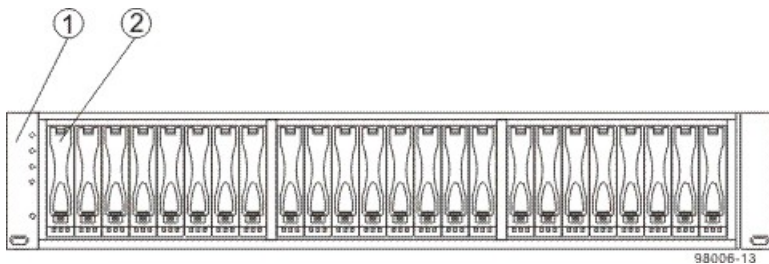

1. End Caps (the Left End Cap Has the Controller-Drive Tray Summary LEDs)
2. Drive Canisters

CE5400 Controller-Drive Tray – Rear View

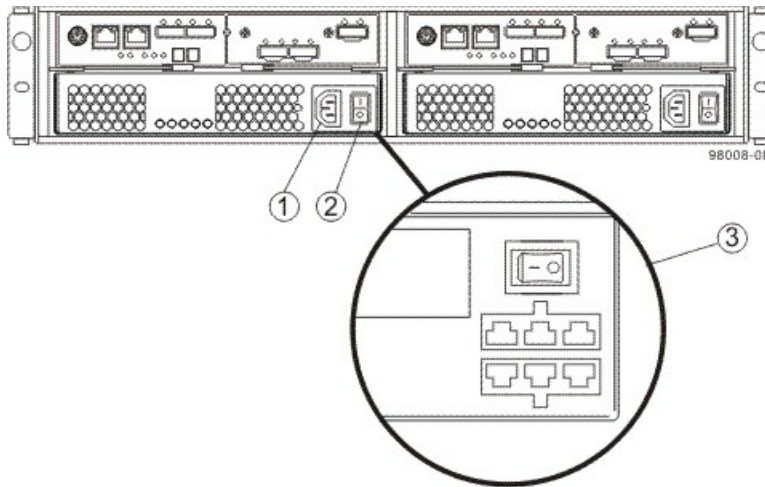

1. AC Power Connector on the AC Power-Fan Canister
2. AC Power Switch
3. DC Power Connector and DC Power Switch on the Optional DC Power-Fan Canister

CE5400 Controller-Drive Tray Dimensions

The CE5400 controller-drive tray conforms to the 48.3-cm (19.0-in.) rack standard.

Dimensions of the CE5400 Controller-Drive Tray (12-Drive Model) – Front View

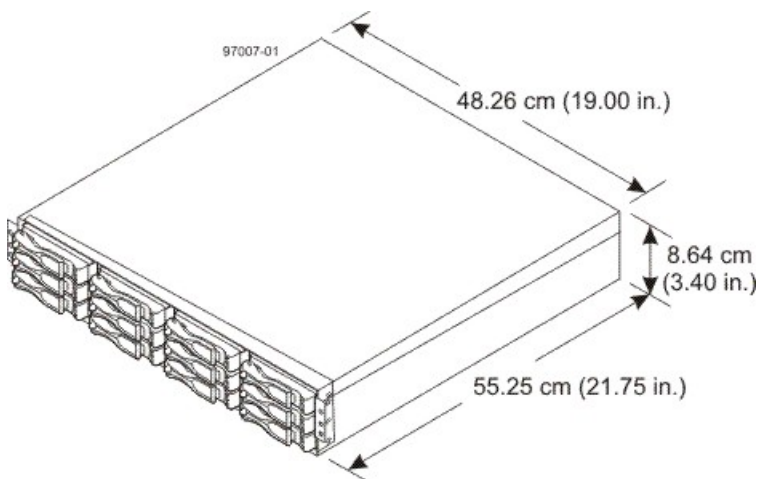

Dimensions of the CE5400 Controller-Drive Tray (24-Drive Model) – Front View

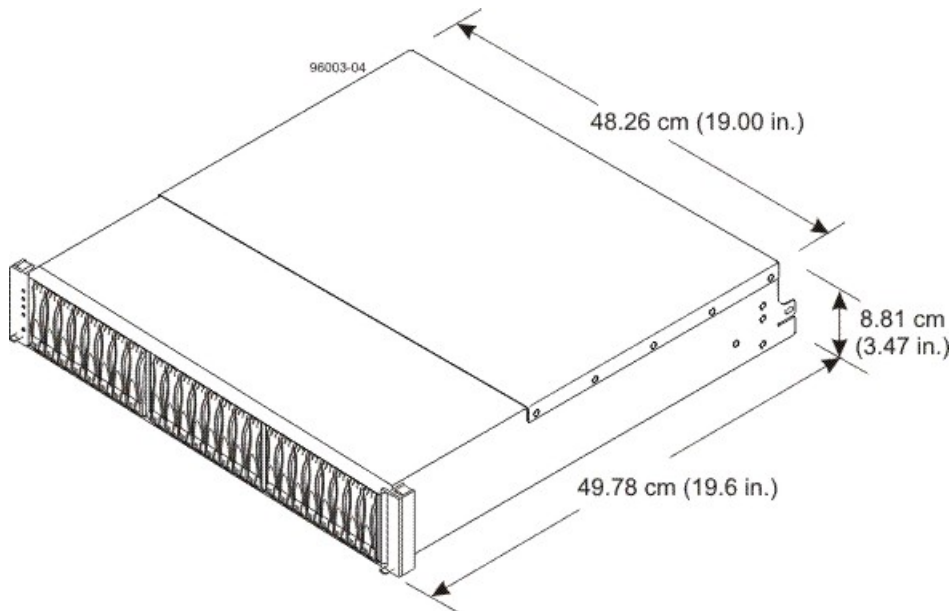

CE5400 Controller-Drive Tray Weight

Weights of the CE5400-12 and CE5400-24 Controller-Drive Trays

| Unit | Weight | | |
|--|------------------|---------------------|--------------------|
| | Maximum* | Empty** | Shipping*** |
| CE5400-12 controller-drive tray, with twelve 8.89-cm (3.5-in.) drives | 27 kg (59.52 lb) | 18.60 kg (41.01 lb) | 31.75 kg (70.0 lb) |
| CE5400-24 controller-drive tray, with twenty-four 6.35-cm (2.5-in.) drives | 26 kg (57.32 lb) | 21.70 kg (47.84 lb) | 31.75 kg (70.0 lb) |

*Maximum weight indicates a controller-drive tray with all of its drives and other components installed. Because drive weights can vary greatly, this value can vary from the value specified as much as either 0.3 kg (0.66 lb) times the maximum number of drives per controller-drive tray for 3.5-in. SATA drives or 0.08 kg (0.18 lb) times the maximum number of drives per controller-drive tray for 2.5-in. SATA drives.

**Empty weight indicates a controller-drive tray with the controller canisters, the power-fan canisters, and the drives removed.

***Shipping weight indicates the maximum weight of the controller-drive tray and all shipping material.

| Component | Weight |
|---------------------|--------------------|
| Controller canister | 2.131 kg (4.70 lb) |
| Power-fan canister | 2.500 kg (5.51 lb) |

| Component | Weight |
|--------------------|------------------|
| 2.5-in. SATA drive | 0.3 kg (0.66 lb) |
| 3.5-in. SATA drive | 1.0 kg (2.2 lb) |

CE5400 Controller-Drive Tray Shipping Dimensions

Shipping Carton Dimensions for the CE5400-12 and CE5400-24 Controller-Drive Trays

| Controller-Drive Tray | Height | Width | Depth |
|---|--------------------|-------------------|-------------------|
| CE5400-12 controller-drive tray with twelve 3.5-in. drives | 24.13 cm (9.5 in.) | 63.50 cm (25 in.) | 58.42 cm (23 in.) |
| CE5400-24 controller-drive tray with twenty-four 2.5-in. drives | 24.13 cm (9.5 in.) | 68.58 cm (27 in.) | 58.42 cm (23 in.) |

CE5400 Controller-Drive Tray Temperature and Humidity

Temperature Requirements and Humidity Requirements for the CE5400-12 and CE5400-24 Controller-Drive Trays

| Condition | Parameter | Requirement |
|-------------------------------------|--|--------------------------------|
| Temperature | Operating range (both cabinet and subsystem) | 10°C to 35°C (50°F to 104°F) |
| | Maximum rate of change | 10°C (50°F) per hour |
| | Storage range | -10°C to 50°C (14°F to 122°F) |
| | Maximum rate of change | 15°C (59°F) per hour |
| | Transit range | -40°C to 60°C (-40°F to 140°F) |
| | Maximum rate of change | 20°C (68°F) per hour |
| Relative humidity (no condensation) | Operating range (both cabinet and subsystem) | 20% to 80% |
| | Storage range | 10% to 90% |
| | Transit range | 5% to 90% |
| | Operating gradient | 10°C (50°F) per hour maximum |
| | Storage gradient | 15°C (59°F) per hour maximum |

| Condition | Parameter | Requirement |
|--|-------------------|------------------------------|
| | Transit gradient | 20°C (68°F) per hour maximum |
| | Maximum dew point | 26°C (79°F) |
| | Maximum gradient | 10% per hour |
| *If you plan to operate a system at an altitude between 1000 m to 3000 m (3280 ft to 9842 ft) above sea level, lower the environmental temperature 1.7°C (3.3°F) for every 1000 m (3280 ft) above sea level. | | |

CE5400 Controller-Drive Tray Altitude Ranges

Altitude Ranges for the CE5400-12 and CE5400-24 Controller-Drive Trays

| Environment | Altitude |
|-------------|---|
| Operating | 30.5 m (100 ft) below sea level to 3000 m (9840 ft) above sea level |
| Storage | 30.5 m (100 ft) below sea level to 3000 m (9840 ft) above sea level |
| Transit | 30.5 m (100 ft) below sea level to 12,000 m (40,000 ft) above sea level |

CE5400 Controller-Drive Tray Airflow and Heat Dissipation

Allow at least 76 cm (30 in.) of clearance in front of the controller-drive tray and 61 cm (24 in.) behind the controller-drive tray for service clearance, ventilation, and heat dissipation.

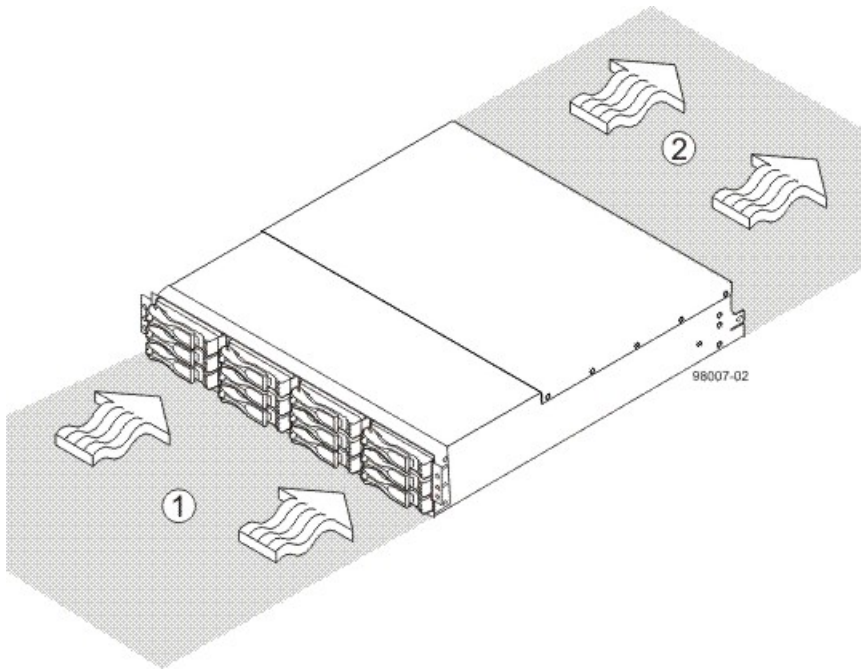
Airflow Through the CE5400-12 Controller-Drive Tray with 12 Drives – Front View

1. 76 cm (30 in.) clearance in front of the cabinet
2. 61 cm (24 in.) clearance behind the cabinet

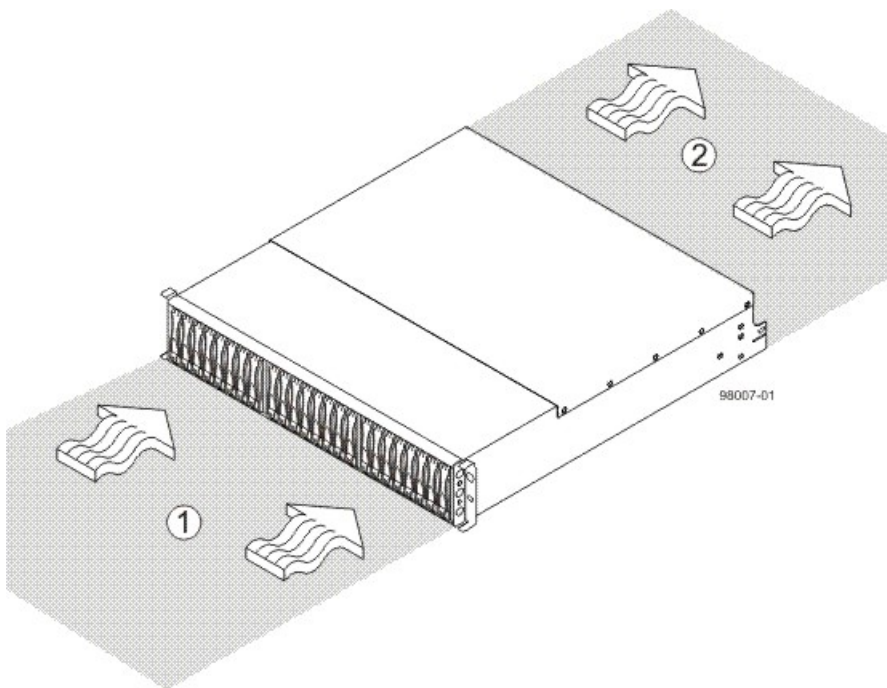
Airflow Through the CE5400-24 Controller-Drive Tray with 24 Drives – Front View

1. 76 cm (30 in.) clearance in front of the cabinet
2. 61 cm (24 in.) clearance behind the cabinet

Power and Heat Dissipation for the CE5400-12 and CE5400-24 Controller-Drive Trays

| Component | KVA | Watts (AC) | Btu/Hr |
|---|-------|------------|--------|
| Controller canisters with two power-fan canisters and 12 drives | 0.400 | 399 | 1366 |
| Controller canisters with two power-fan canisters and 24 drives | 0.331 | 330 | 1127 |

CE5400 Controller-Drive Tray Acoustic Noise

Acoustic Noise at 25°C for the CE5400-12 and CE5400-24 Controller-Drive Trays

| Measurement | Level |
|-----------------------------------|------------------|
| Sound power (standby operation) | 6.5 bels maximum |
| Sound pressure (normal operation) | 65 dBA maximum |

CE5400 Controller-Drive Tray Site Wiring and Power

The CE5400 controller-drive tray uses wide-ranging, redundant power supplies that automatically accommodate voltages to the AC power source or the optional –48-VDC power source. The power supplies meet standard voltage requirements for both North American (USA and Canada) operation and worldwide (except USA and Canada) operation. The power supplies use standard industrial wiring with line-to-neutral or line-to-line power connections.

 **NOTE** Power for the optional –48-VDC power configuration is supplied by a centralized DC power plant instead of the AC power source in the cabinet. Refer to the associated manufacturer's documentation for specific DC power source requirements.

Keep this information in mind when you prepare the installation site for the controller-drive tray:

- **Protective ground** – Site wiring must include a protective ground connection to the AC power source or the optional –48-VDC power source.

 **NOTE** *Protective ground* is also known as safety ground or chassis ground.

- **Circuit overloading** – Power circuits and associated circuit breakers must provide enough power and overload protection. To prevent damage to the controller-drive tray, isolate its power source from large switching loads, such as air-conditioning motors, elevator motors, and factory loads.
- **Power interruptions** – The controller-drive tray can withstand these applied voltage interruptions:
 - **Input transient** – 50 percent of the nominal voltage
 - **Duration** – One-half cycle
 - **Frequency** – Once every 10 seconds
- **Power failures** – If a total power failure occurs, the controller-drive tray automatically performs a power-on recovery sequence without operator intervention.

CE5400 Controller-Drive Tray Power Input

AC Power Input

Each power supply contains one 10-A slow-blow fuse.

AC Power Requirements for the CE5400-12 and CE5400-24 Controller-Drive Trays

| Parameter | Low Range | High Range |
|---|-------------|-------------|
| Nominal voltage | 100 VAC | 240 VAC |
| Frequency | 50 to 60 Hz | 50 to 60 Hz |
| Idle current | 3.97 A* | 1.63 A** |
| Maximum operating current | 4.25 A* | 1.68 A** |
| Sequential Drive Group Spin Up | 4.27 A | 1.76 A |
| Simultaneous Drive Spin Up | 6.13 A | 2.71 A |
| System Rating Plate Label | 7.0 A | 2.9 A |
| <p>* Typical current: 100 VAC, 60 Hz at 0.87 power supply efficiency and 0.99 power factor. These numbers can vary significantly, depending upon the drives tested in the particular configuration.</p> <p>**Typical current: 240 VAC, 60 Hz at 0.87 power supply efficiency and 0.99 power factor. These numbers can vary significantly, depending upon the drives tested in the particular configuration.</p> | | |

DC Power Input

Nominal input voltages for the DC power source are as follows:

- Low range: -42 VDC
- High range: -60 VDC

The maximum operating current is 21.7 A.

CE5400 Controller-Drive Tray Power Factor Correction

Power factor correction is applied within the power supply, which maintains the power factor of the CE5400-12 and CE5400-24 controller-drive trays at greater than 0.95 with nominal input voltage.

CE5400 Controller-Drive Tray AC Power Cords and Receptacles

Each CE5400 controller-drive tray is shipped with two AC power cords, which use the standard AC outlets in the destination country. Each AC power cord connects one of the power supplies in the drive tray to an independent, external AC power source, such as a wall receptacle, or to any uninterruptible power supply (UPS).

If you have a cabinet with internal power cabling, such as a ladder cord, you do not need the AC power cords that are shipped with the controller-drive tray.

DC power is an option that is available for use with your controller-drive tray and drive trays.

CE5400 Controller-Drive Tray Optional DC Power Connector Cables and Source Wires

The CE5400-12 controller-drive tray and the CE5400-24 controller-drive tray is shipped with –48-VDC power connector cables if the DC power option is ordered. The –48-VDC power connector cable plugs into the DC power connector on the rear of the controller-drive tray. The three source wires on the other end of the power connector cable connect the controller-drive tray to centralized DC power plant equipment, typically through a bus bar above the cabinet.

WARNING (W12) Risk of electrical shock – This unit has more than one power source. To remove all power from the unit, all DC MAINS must be disconnected by removing all power connectors (item 4 below) from the power supplies.

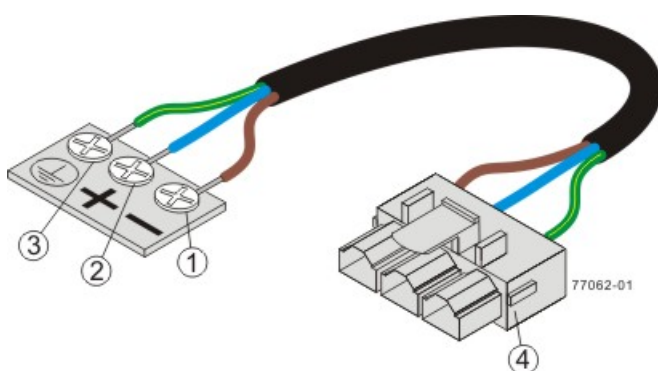

1. Supply (Negative), Brown Wire, –48 VDC
2. Return (Positive), Blue Wire
3. Ground, Green and Yellow Wire
4. DC Power Connector

WARNING (W14) Risk of bodily injury – A qualified service person is required to make the DC power connection according to NEC and CEC guidelines.

Two (or, optionally, four) DC power connector cables are provided with each controller-drive tray. Two DC power connectors are on the two DC power supplies on the rear of each controller-drive tray if additional redundancy is required.

NOTE It is not mandatory that you connect the second DC power connection on the DC power supplies of the controller-drive tray. The second DC power connection is provided for additional redundancy only and can be connected to a second DC power bus.

Preparing the Network for the Controllers

If you plan to use Ethernet connections from the storage management station to the controllers, you will use the out-of-band management method. For this configuration, meet with your network administrator before you order and install the equipment so that you can prepare for the setup and management of the devices on the IP network. Each controller uses its Ethernet management ports to connect to the IP network and communicate with the other devices on the IP network (often requiring a special application to set up the protocol).

Your network administrator can pre-assign the addresses that you need to manage the communication between the devices on the IP network. Depending on your storage configuration, you will need the following addresses:

- Up to two network IP addresses for each controller
- Up to two subnet mask addresses for each controller
- Either two IPv4 addresses (one static and one dynamic) or one IPv6 address for each controller
- A Dynamic Host Configuration Protocol (DHCP) address for each controller

If switches are used in your storage environment, you must know if zoning will be used, and how it will be configured.

Specifications of the CE5400-60 Controller-Drive Tray

The CE5400-60 controller-drive tray is a high-density SAS 2.0 (6-Gb/s) drive enclosure with 60 near-line 3.5 in. SAS drives, housed in five drawers with 12 drives each.

CE5400-60 Controller-Drive Tray – Front View with Bezel Removed

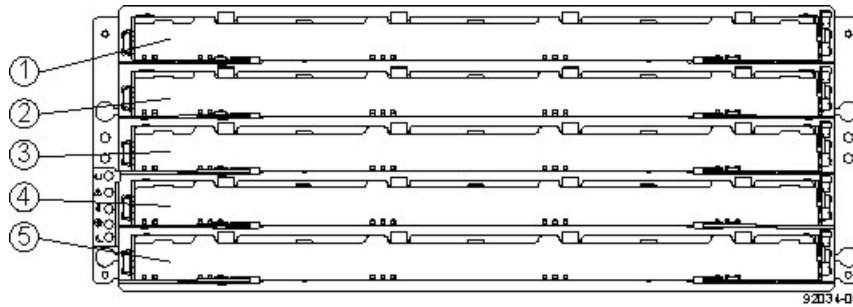

1. Drive Drawer 1
2. Drive Drawer 2
3. Drive Drawer 3
4. Drive Drawer 4
5. Drive Drawer 5

CE5400-60 Controller-Drive Tray – Rear View

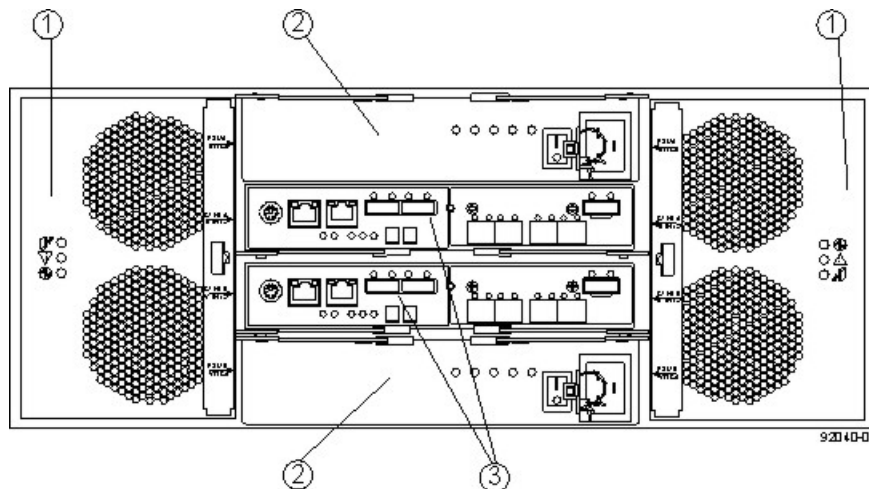

1. Fan Canisters
2. Power Canisters
3. Controller-Drive Tray Canisters

CE5400-60 Controller-Drive Tray Dimensions

The CE5400-60 controller-drive tray conforms to the 48.3-cm (19.0-in.) rack standard.

Dimensions of the CE5400-60 Controller-Drive Tray – Front View

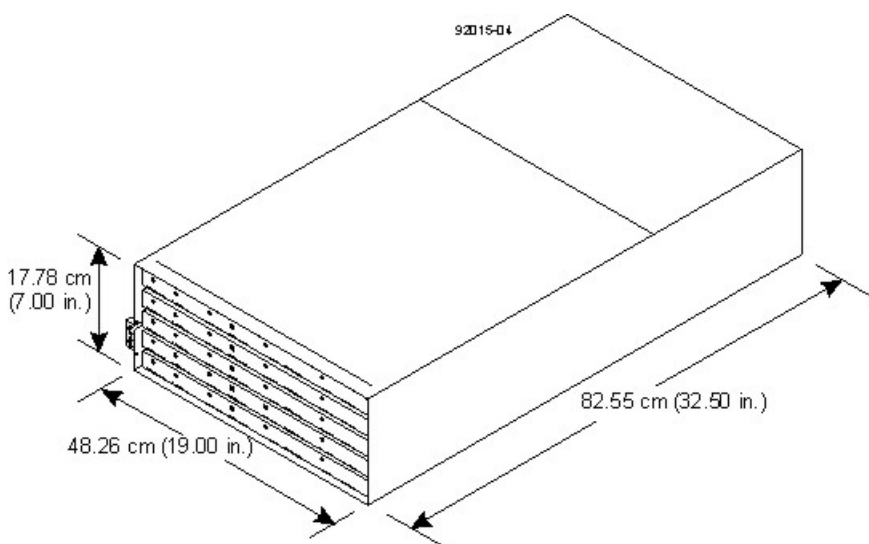

CE5400-60 Controller-Drive Tray Weight

Weights of the CE5400-60 Controller-Drive Tray

| Unit | Weight | | |
|---------------------------------|-------------------|------------------|-------------------|
| | Maximum* | Empty** | Shipping*** |
| CE5400-60 controller-drive tray | 105.2 kg (232 lb) | 59.8 kg (132 lb) | 193.2 kg (426 lb) |

*Maximum weight indicates a controller-drive tray with all of its drives and other components installed. Because drive weights can vary greatly, this value can vary from the value specified as much as 0.3 kg (0.6 lb) times the maximum number of drives per drive tray for drives weighing 0.725 kg (1.6 lb).

**Empty weight indicates a drive tray without the controller canisters, the power canisters, the fan canisters, and the drives.

***Shipping weight indicates the empty weight of a drive tray and all shipping material, as well as the weight of the 60 drives that are shipped separately in multipack cartons.

Component Weights of the CE5400-60 Controller-Drive Tray

| Component | Weight |
|---------------------|------------------------------|
| Controller canister | 2.99 kg (6.60 lb) |
| Power canister | 2.5 kg (5.5 lb) |
| Fan canister | Approximately 1 kg (2.16 lb) |
| Drive | 0.74 kg (1.64 lb) |

CE5400-60 Controller-Drive Tray Shipping Dimensions

Shipping Carton Dimensions for the CE5400-60 Controller-Drive Tray

| Height | Width | Depth |
|-------------------|----------------------|-----------------------|
| 48.26 cm (19 in.) | 60.96 cm (24.00 in.) | 100.97 cm (39.75 in.) |

CE5400-60 Controller-Drive Tray Temperature and Humidity

Temperature Requirements and Humidity Requirements for the CE5400-60 Controller-Drive Tray

| Condition | Parameter | Requirement |
|---|--|--------------------------------|
| Temperature | Operating range (both cabinet and subsystem) | 10°C to 35°C (50°F to 104°F) |
| | Maximum rate of change | 10°C (50°F) per hour |
| | Storage range | -10°C to 50°C (14°F to 122°F) |
| | Maximum rate of change | 15°C (59°F) per hour |
| | Transit range | -40°C to 60°C (-40°F to 140°F) |
| | Maximum rate of change | 20°C (68°F) per hour |
| Relative humidity (no condensation) | Operating range (both cabinet and subsystem) | 20% to 80% |
| | Storage range | 10% to 90% |
| | Transit range | 5% to 90% |
| | Operating gradient | 10°C (50°F) per hour maximum |
| | Storage gradient | 15°C (59°F) per hour maximum |
| | Transit gradient | 20°C (68°F) per hour maximum |
| | Maximum dew point | 26°C (79°F) |
| | Maximum gradient | 10% per hour |
| If you plan to operate a system at an altitude between 1000 m to 3000 m (3280 ft to 9842 ft) above sea level, lower the environmental temperature 1.7°C (3.3°F) for every 1000 m (3280 ft) above sea level. | | |

CE5400-60 Controller-Drive Tray Altitude Ranges

Altitude Ranges for the CE5400-60 Controller-Drive Tray

| Environment | Altitude |
|-------------|---|
| Operating | 30.5 m (100 ft) below sea level to 3000 m (9842 ft) above sea level |
| Storage | 30.5 m (100 ft) below sea level to 3000 m (9842 ft) above sea level |
| Transit | 30.5 m (100 ft) below sea level to 12,000 m (40,000 ft) above sea level |

CE5400-60 Controller-Drive Tray Airflow and Heat Dissipation

Airflow goes from the front of the CE5400-60 controller-drive tray to the rear of the controller-drive tray. Allow at least 81 cm (32 in.) of clearance in front of the CE5400-60 controller-drive tray and at least 61 cm (24 in.) of clearance behind the controller-drive tray for service clearance, ventilation, and heat dissipation.

Airflow Through the CE5400-60 Controller-Drive Tray – Front View

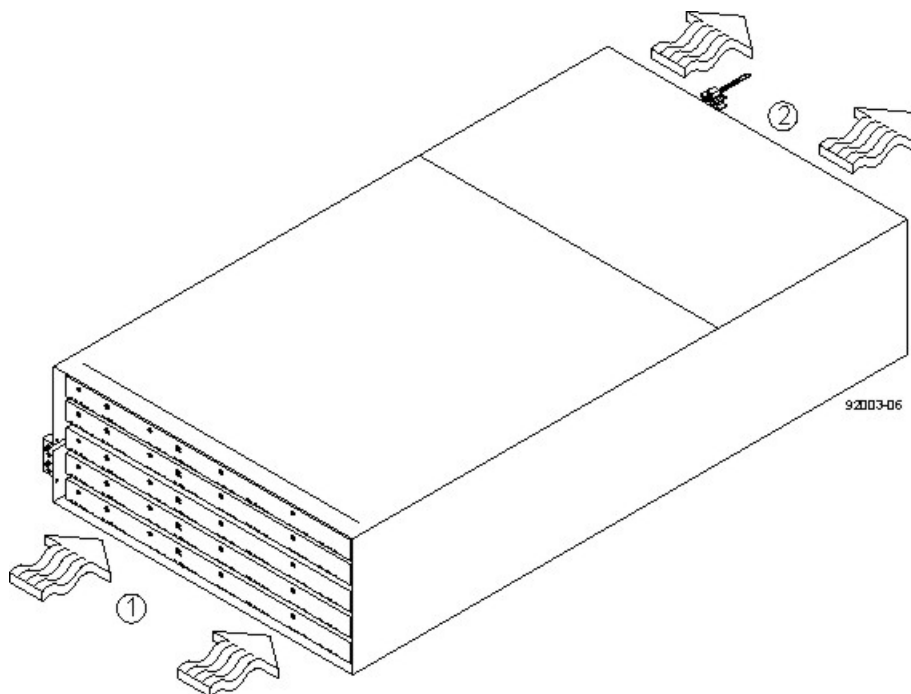

1. 81 cm (32 in.) clearance in front of the cabinet
2. 61 cm (24 in.) clearance behind the cabinet

The tabulated power and heat dissipation values in the following table are the maximum measured operating power.

Power Ratings and Heat Dissipation for the CE5400-60 Controller-Drive Tray

| Unit | KVA | Watts (AC) | Btu/hr |
|--|-------|------------|--------|
| CE5400-60 controller-drive tray with two power supplies, two controller trays, 60 drives (Seagate 2000-Gb SAS drives and controllers), and two fan canisters, full speed | 1.268 | 1222 | 4180 |

CE5400-60 Controller-Drive Tray Acoustic Noise

Acoustic Noise at 25°C for the CE5400-60 Controller-Drive Tray

| Measurement | Level |
|---------------------------------|----------|
| Sound power (standby operation) | 6.5 bels |
| Sound power (normal operation) | 6.8 bels |
| Sound pressure | 68 dBA |

CE5400-60 Controller-Drive Tray Site Wiring and Power

The CE5400-60 controller-drive tray uses wide-ranging, redundant power supplies that automatically accommodate voltages to the AC power source. The power supplies meet standard voltage requirements for both North American (USA and Canada) operation and worldwide (except USA and Canada) operation. The power supplies use standard industrial wiring with line-to-neutral power connections or line-to-line power connections.

Keep this information in mind when you prepare the installation site for the controller-drive tray:

- **Protective ground** – Site wiring must include a protective ground connection to the AC power source.



NOTE *Protective ground* is also known as safety ground or chassis ground.

- **Circuit overloading** – Power circuits and associated circuit breakers must provide enough power and overload protection. To prevent damage to the drive tray, isolate its power source from large switching loads, such as air-conditioning motors, elevator motors, and factory loads.
- **Power interruptions** – The controller-drive tray can withstand these applied voltage interruptions:
 - **Input transient** – 50 percent of the nominal voltage
 - **Duration** – One-half cycle
 - **Frequency** – Once every 10 seconds
- **Power failures** – If a total power failure occurs, the drive tray automatically performs a power-on recovery sequence without operator intervention after the power is restored.

CE5400-60 Controller-Drive Tray Power Input

Each power supply contains one 15-A slow-blow fuse.

AC Power Requirements for the CE5400-60 Controller-Drive Tray

| Parameter | Low Range | High Range |
|---------------------------|-----------|------------|
| Nominal voltage | 200 VAC | 240 VAC |
| Frequency | 50 Hz | 60 Hz |
| Typical Operating Current | 4.9 A | 5.75 A |
| System Nameplate Rating | 6.3 A | 7.56 A |

CE5400-60 Controller-Drive Tray Power Factor Correction

Power factor correction is applied within the power supply, which maintains the power factor of the CE5400-60 controller-drive tray at greater than 0.95 with nominal input voltage.

CE5400-60 Controller-Drive Tray AC Power Cords and Receptacles

Each CE5400-60 controller-drive tray is shipped with two AC power cords, which fit the standard AC outlets in the destination country. Each AC power cord connects one of the power canisters in the drive tray to an independent, external AC power source, such as a wall receptacle, or to any uninterruptible power supply (UPS).



NOTE Possible risk of equipment failure – To ensure proper cooling, the CE5400-60 controller-drive tray always uses two power supplies.

Preparing the Network for the Controllers

If you plan to use Ethernet connections from the storage management station to the controllers, you will use the out-of-band management method. For this configuration, meet with your network administrator before you order and install the equipment so that you can prepare for the setup and management of the devices on the IP network. Each controller uses its Ethernet management ports to connect to the IP network and communicate with the other devices on the IP network (often requiring a special application to set up the protocol).

Your network administrator can pre-assign the addresses that you need to manage the communication between the devices on the IP network. Depending on your storage configuration, you will need the following addresses:

- Up to two network IP addresses for each controller
- Up to two subnet mask addresses for each controller
- Either two IPv4 addresses (one static and one dynamic) or one IPv6 address for each controller
- A Dynamic Host Configuration Protocol (DHCP) address for each controller

If switches are used in your storage environment, you must know if zoning will be used, and how it will be configured.

Specifications of the CE4900 Controller-Drive Tray

The CE4900 controller-drive tray is available as a rackmount model that provides high-capacity disk storage for Fibre Channel or iSCSI environments.

The CE4900 controller-drive tray contains the components shown in the following figure.

CE4900 Controller-Drive Tray – Front View and Rear View

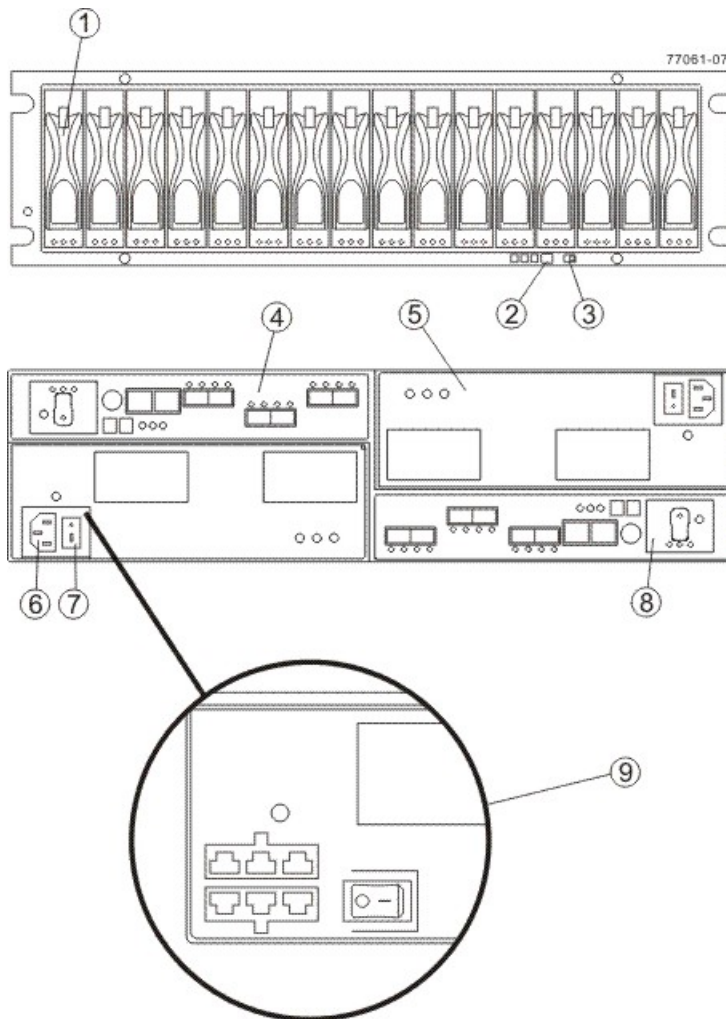

1. (Front View) Drive Canister
2. Alarm Mute Switch
3. (Rear View) Link Rate Switch
4. Controller A (Inverted)
5. Power-Fan Canister
6. AC Power Connector
7. AC Power Switch
8. Battery Canister
9. Optional DC Power Connector and DC Power Switch

CE4900 Controller-Drive Tray Dimensions

The CE4900 controller-drive tray conforms to the 48.3-cm (19.0-in.) rack standard.

Dimensions of the CE4900 Controller-Drive Tray – Front View

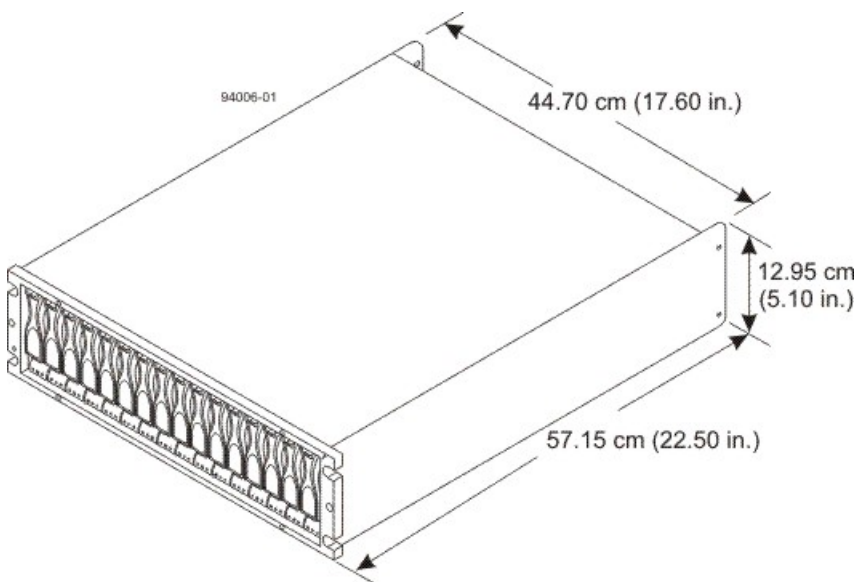

CE4900 Controller-Drive Tray Weight

Weights of the CE4900 Controller-Drive Tray

| Unit | Weight | | |
|--|--------------------|--------------------|---------------------|
| | Maximum* | Empty** | Shipping*** |
| CE4900 controller-drive tray | 38.15 kg (84.1 lb) | 22.67 kg (50.0 lb) | 51.70 kg (114.0 lb) |
| <p>*Maximum weight indicates a controller-drive tray with all of its drives and other components installed. Because drive weights can vary greatly, this value can vary from the value specified as much as 0.3 kg (0.6 lb) times the maximum number of drives per controller-drive tray for drives weighing 1.0 kg (2.2 lb).</p> <p>**Empty weight indicates a controller-drive tray with the controller canisters, the power-fan canisters, and the drives removed.</p> <p>***Shipping weight indicates the maximum weight of a controller-drive tray and all shipping material.</p> | | | |

Component Weights of the Controller-Drive Tray

| Component | Weight |
|---------------------|--------------------|
| Controller canister | 1.995 kg (4.40 lb) |
| Power-fan canister | 3.629 kg (8.00 lb) |
| ESM canister | 1.814 kg (4.00 lb) |
| Battery | 0.544 kg (1.20 lb) |

| Component | Weight |
|-----------|-------------------------------|
| Drive | Approximately 1.0 kg (2.2 lb) |

CE4900 Controller-Drive Tray Shipping Dimensions

Shipping Carton Dimensions for the CE4900 Controller-Drive Tray

| Height | Width | Depth |
|---|----------------------|----------------------|
| 45.72 cm (18.00 in.) – Includes the height of the pallet. | 60.96 cm (24.00 in.) | 81.28 cm (32.00 in.) |

CE4900 Controller-Drive Tray Temperature and Humidity

Temperature Requirements and Humidity Requirements for the CE4900 Controller-Drive Tray

| Condition | Parameter | Requirement |
|-------------------------------------|------------------------|--|
| Temperature* | Operating range | 10°C to 40°C (50°F to 104°F) without the battery 10°C to 35°C (50°F to 95°F) with the battery |
| | Maximum rate of change | 10°C (18°F) per hour |
| | Storage range | –10°C to 50°C (14°F to 122°F) without the battery –10°C to 45°C (14°F to 113°F) with the battery (three-month maximum in storage) |
| | Maximum rate of change | 15°C (27°F) per hour |
| | Transit range | –40°C to 60°C (–40°F to 140° F) without the battery –20°C to 60°C (–4°F to 140°F) with the battery (one-week maximum in transit) |
| | Maximum rate of change | 20°C (36°F) per hour |
| Relative humidity (no condensation) | Operating range | 20% to 80% |
| | Storage range | 10% to 90% |
| | Transit range | 5% to 95% |
| | Maximum dew point | 26°C (79°F) |

| Condition | Parameter | Requirement |
|--|------------------|--------------|
| | Maximum gradient | 10% per hour |
| *If you plan to operate a system at an altitude between 1000 m to 3000 m (3280 ft to 9842 ft) above sea level, lower the environmental temperature 1.7°C (3.3°F) for every 1000 m (3280 ft) above sea level. | | |

CE4900 Controller-Drive Tray Altitude Ranges

Altitude Ranges for the CE4900 Controller-Drive Tray

| Environment | Altitude |
|-------------|---|
| Operating | 30.5 m (100 ft) below to 3,000 m (9840 ft) above sea level |
| Storage | 30.5 m (100 ft) below to 3,000 m (9840 ft) above sea level |
| Transit | 30.5 m (100 ft) below to 12,000 m (40,000 ft) above sea level |

CE4900 Controller-Drive Tray Airflow and Heat Dissipation

Airflow goes from the front of the controller-drive tray to the rear of the controller-drive tray. Allow at least 76 cm (30 in.) of clearance in front of the controller-drive tray and at least 61 cm (24 in.) of clearance behind the controller-drive tray for service clearance, ventilation, and heat dissipation.

Airflow Through the CE4900 Controller-Drive Tray – Front View

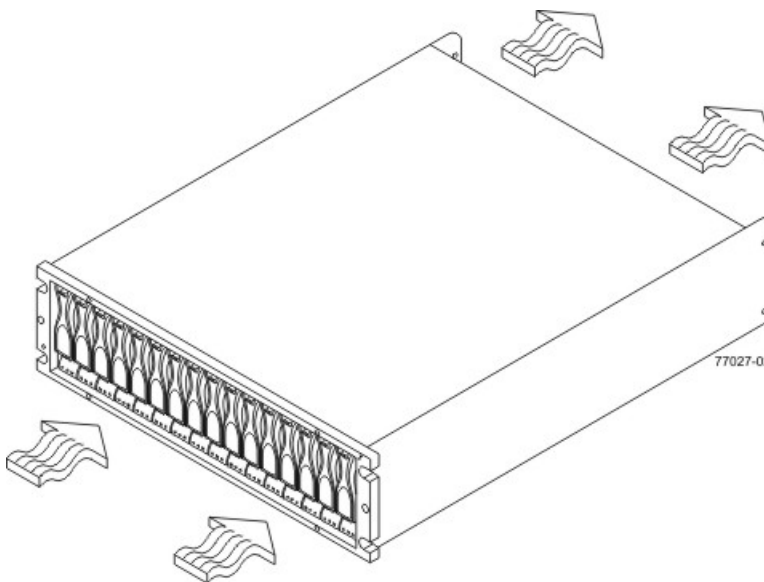

The tabulated power and heat dissipation values in the following table are the maximum measured operating power. Maximum configuration units are typically operated at high data rates or have larger random access memory (RAM) capabilities.

Power Ratings and Heat Dissipation for the CE4900 Controller-Drive Tray

| Component | KVA | Watts (AC) | Btu/Hr | Amps (240 VAC) |
|------------------------------|-------|------------|--------|----------------|
| CE4900 controller-drive tray | 0.624 | 600 | 2047 | 2.50 |

CE4900 Controller-Drive Tray Acoustic Noise

Sound Levels for the CE4900 Controller-Drive Tray

| Measurement | Level |
|----------------|----------|
| Sound power | 6.5 bels |
| Sound pressure | 65 dBA |

CE4900 Controller-Drive Tray Site Wiring and Power

The agency ratings for the CE4900 controller-drive tray are 6.00 A at 100 VAC and 2.50 A at 240 VAC. These ratings are the overall maximum AC currents for this system.

The CE4900 controller-drive tray uses wide-ranging, redundant power supplies that automatically accommodate voltages to the AC power source or the optional –48-VDC power source. The power supplies meet standard voltage requirements for both North American (USA and Canada) operation and worldwide (except USA and Canada) operation. The power supplies use standard industrial wiring with line-to-neutral or line-to-line power connections.

 **NOTE** Power for the optional –48-VDC power configuration is supplied by a centralized DC power plant instead of the AC power source in the cabinet. Refer to the associated manufacturer's documentation for specific DC power source requirements.

Keep this information in mind when you prepare the installation site for the controller-drive tray:

- **Protective ground** – Site wiring must include a protective ground connection to the AC power source or the optional –48-VDC power source.

 **NOTE** *Protective ground* is also known as safety ground or chassis ground.

- **Circuit overloading** – Power circuits and associated circuit breakers must provide enough power and overload protection. To prevent damage to the controller-drive tray, isolate its power source from large switching loads, such as air-conditioning motors, elevator motors, and factory loads.
- **Power interruptions** – The controller-drive tray can withstand these applied voltage interruptions:
 - **Input transient** – 50 percent of the nominal voltage
 - **Duration** – One-half cycle
 - **Maximum frequency** – Once every 10 seconds
- **Power failures** – If a total power failure occurs, the controller-drive tray automatically performs a power-on recovery sequence without operator intervention after the power is restored.



NOTE When a power failure occurs, the controller-drive tray uses battery power to back up the data that is in cache.

If you are installing a large storage system configuration, you must make sure that you are supplying the correct AC source voltages, and not creating an over-current situation.

CE4900 Controller-Drive Tray Power Input

AC Power Input

Each power supply contains one 15-A slow-blow fuse.

AC Power Requirements for the CE4900 Controller-Drive Tray

| Parameter | Low Range | High Range |
|---|-------------|-------------|
| Nominal voltage | 115 VAC | 230 VAC |
| Frequency | 50 to 60 Hz | 50 to 60 Hz |
| Idle current | 3.81 A* | 1.98 A** |
| Maximum operating current | 3.96 A* | 2.06 A** |
| Maximum surge current | 5.52 A* | 2.72 A** |
| *Typical current: 115 VAC, 60 Hz at 0.77 power supply efficiency and 0.96 power factor. **Typical current: 230 VAC, 60 Hz at 0.77 power supply efficiency and 0.96 power factor. | | |

DC Power Input

Nominal input voltages for the DC power source are as follows:

- Low range: -36 VDC
- High range: -72 VDC

The maximum operating current is 17 A.

CE4900 Controller-Drive Tray Power Factor Correction

Power factor correction is applied within the power-fan canister of each CE4900 controller-drive tray, which maintains the power factor of the controller-drive tray at greater than 0.96 with nominal input voltage.

CE4900 Controller-Drive Tray AC Power Cords and Receptacles

Each CE4900 controller-drive tray is shipped with two AC power cords, which fit the standard AC outlets in the destination country. Each AC power cord connects one of the power-fan canisters in the controller-drive tray to an independent, external AC power source, such as a wall receptacle or an uninterruptible power supply (UPS).

DC power is an option that is available for use with your controller-drive tray and drive tray. For more information, see “[CE4900 Controller-Drive Tray Optional DC Power Connector Cables and Source Wires](#)”.

If you have a cabinet with internal power cabling, such as a ladder cord, you do not need the AC power cords that are shipped with the controller-drive tray.

CE4900 Controller-Drive Tray Optional DC Power Connector Cables and Source Wires

The CE4900 controller-drive tray is shipped with –48-VDC power connector cables if the DC power option is ordered. The –48-VDC power connector cable plugs into the DC power connector on the rear of the controller-drive tray. The three source wires on the other end of the power connector cable connect the controller-drive tray to centralized DC power plant equipment, typically through a bus bar above the cabinet.

WARNING (W12) Risk of electrical shock – This unit has more than one power source. To remove all power from the unit, all DC MAINS must be disconnected by removing all power connectors (item 4 below) from the power supplies.

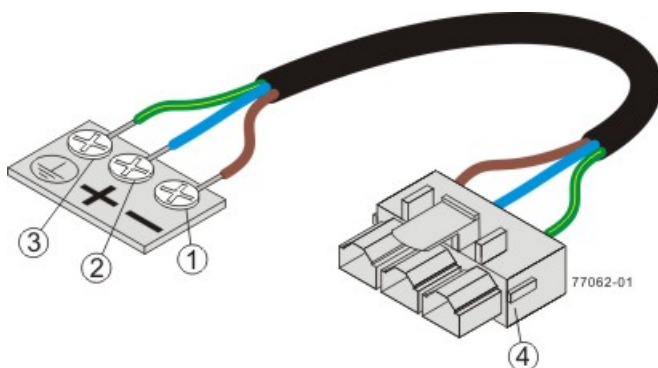

1. Supply (Negative), Brown Wire, –48 VDC
2. Return (Positive), Blue Wire
3. Ground, Green and Yellow Wire
4. DC Power Connector

WARNING (W14) Risk of bodily injury – A qualified service person is required to make the DC power connection according to NEC and CEC guidelines.

Two (or, optionally, four) DC power connector cables are provided with each controller-drive tray. Two DC power connectors are on the two DC power supplies on the rear of each controller-drive tray if additional redundancy is required.

NOTE It is not mandatory that you connect the second DC power connection on the DC power supplies of the controller-drive tray. The second DC power connection is provided for additional redundancy only and can be connected to a second DC power bus.

Preparing the Network for the Controllers

If you plan to use Ethernet connections from the storage management station to the controllers, you will use the out-of-band management method. For this configuration, meet with your network administrator before you order and install the equipment so that you can prepare for the setup and management of the devices

on the IP network. Each controller uses its Ethernet management ports to connect to the IP network and communicate with the other devices on the IP network (often requiring a special application to set up the protocol).

Your network administrator can pre-assign the addresses that you need to manage the communication between the devices on the IP network. Depending on your storage configuration, you will need the following addresses:

- Up to two network IP addresses for each controller
- Up to two subnet mask addresses for each controller
- Either two IPv4 addresses (one static and one dynamic) or one IPv6 address for each controller
- A Dynamic Host Configuration Protocol (DHCP) address for each controller

If switches are used in your storage environment, you must know if zoning will be used, and how it will be configured.

Specifications of the CDE3994 Controller-Drive Tray

The CDE3994 controller-drive tray is available as a rackmount model or a deskside model that provides high-capacity disk storage for Fibre Channel environments.

The CDE3994 controller-drive tray contains these components:

- A maximum of 16 Fibre Channel or SATA drives
- Two power-fan canisters
- One or two controllers

CDE3994 Controller-Drive Tray (Rackmount Model) – Front View and Rear View

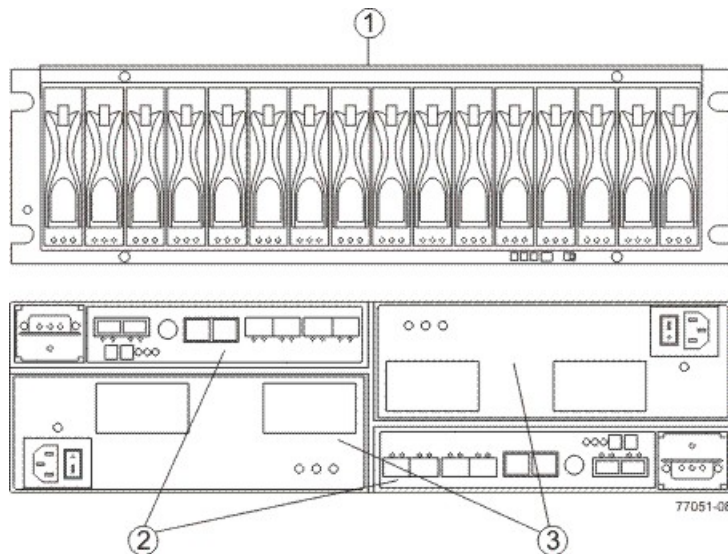

1. Drive Canisters
2. Controller Canisters
3. Power-Fan Canisters

Usually an AC power source is used to supply power to the power-fan canister. A DC power option is also available.

Power Source Options for the CDE3994 Controller-Drive Tray – Rear View

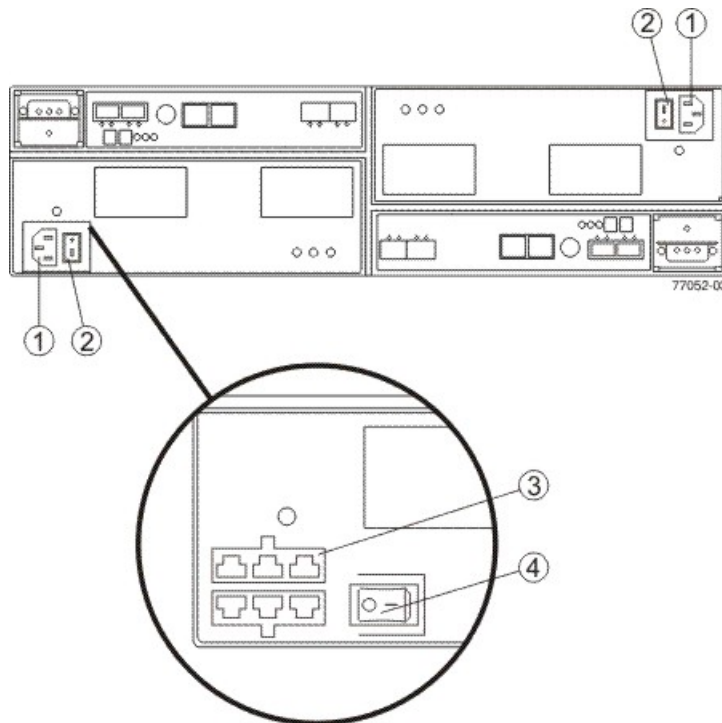

1. AC Power Connectors
2. AC Power Switches
3. (Optional) Two DC Power Connectors
4. (Optional) DC Power Switch

CDE3994 Controller-Drive Tray Dimensions

The CDE3994 controller-drive tray conforms to the 48.3-cm (19.0-in.) rack standard.

Dimensions of the CDE3994 Controller-Drive Tray (Deskside Model and Rackmount Model) – Front View

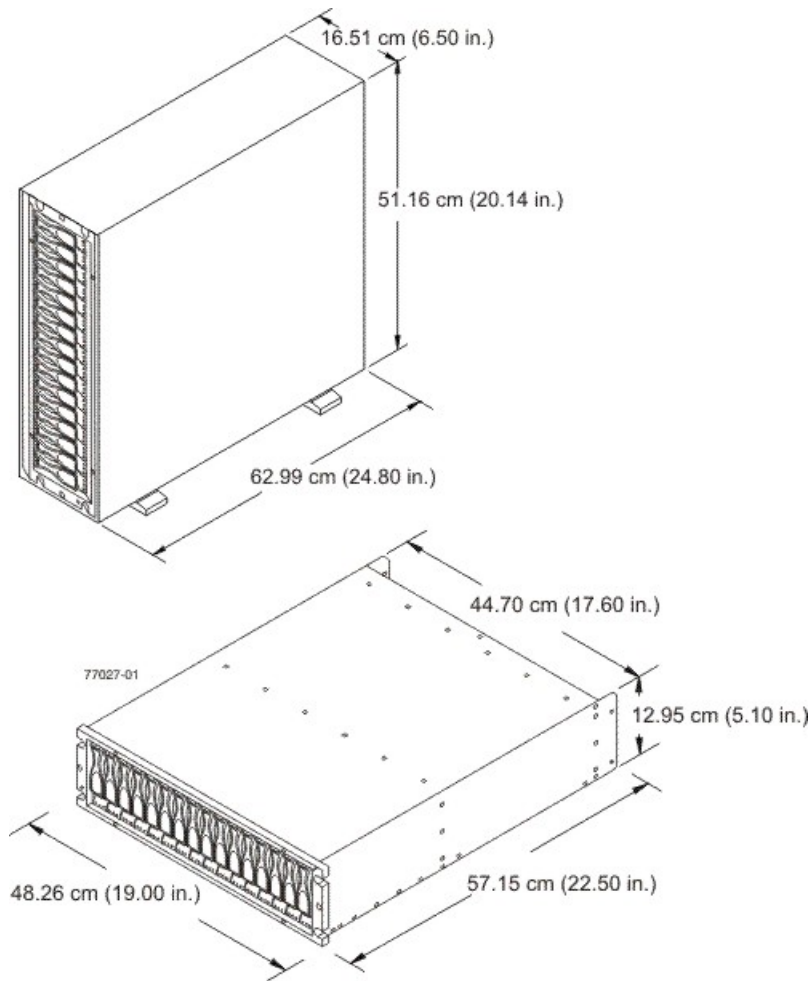

CDE3994 Controller-Drive Tray Weight

Weights of the CDE3994 Controller-Drive Tray

| Unit | Weight | | |
|--|---------------|--------------------|---------------------|
| | Maximum* | Empty** | Shipping*** |
| CDE3994 controller-drive tray | 41 kg (91 lb) | 15.88 kg (35.0 lb) | 52.16 kg (115.0 lb) |
| <p>*Maximum weight indicates a controller-drive tray with all of its drives and other components installed. Because drive weights can vary greatly, this value can vary from the value specified as much as 0.3 kg (0.6 lb) times the maximum number of drives per controller-drive tray for drives weighing 1.0 kg (2.2 lb).</p> <p>**Empty weight indicates a controller-drive tray with the controller canisters, the power-fan canisters, and the drives removed.</p> <p>***Shipping weight indicates the maximum weight of a controller-drive tray and all shipping material.</p> | | | |

CDE3994 Controller-Drive Tray Shipping Dimensions

Shipping Carton Dimensions for the CDE3994 Controller-Drive Tray

| Height | Width | Depth |
|---|----------------------|----------------------|
| 45.72 cm (18.00 in.) – Includes the height of the pallet. | 62.23 cm (24.50 in.) | 80.65 cm (31.75 in.) |

CDE3994 Controller-Drive Tray Temperature and Humidity

Temperature Requirements and Humidity Requirements for the CDE3994 Controller-Drive Tray

| Condition | Parameter | Requirement |
|--|------------------------|--|
| Temperature* | Operating range | 10°C to 40°C (50°F to 104°F) without the battery 10°C to 35°C (50°F to 95°F) with the battery |
| | Maximum rate of change | 10°C (18°F) per hour |
| | Storage range | –10°C to 50°C (14°F to 122°F) without the battery –10°C to 45°C (14°F to 113°F) with the battery (three-month maximum in storage) |
| | Maximum rate of change | 15°C (27°F) per hour |
| | Transit range | –40°C to 60°C (–40°F to 140° F) without the battery –20°C to 60°C (–4°F to 140°F) with the battery (one-week maximum in transit) |
| | Maximum rate of change | 20°C (36°F) per hour |
| Relative humidity (no condensation) | Operating range | 20% to 80% |
| | Storage range | 10% to 90% |
| | Transit range | 5% to 95% |
| | Maximum dew point | 26°C (79°F) |
| | Maximum gradient | 10% per hour |
| *If you plan to operate a system at an altitude between 1000 m to 3000 m (3280 ft to 9842 ft) above sea level, lower the environmental temperature 1.7°C (3.3°F) for every 1000 m (3280 ft) above sea level. | | |

CDE3994 Controller-Drive Tray Altitude Ranges

Altitude Ranges for the CDE3994 Controller-Drive Tray

| Environment | Altitude |
|-------------|---|
| Operating | 30.5 m (100 ft) below to 3,000 m (9840 ft) above sea level |
| Storage | 30.5 m (100 ft) below to 3,000 m (9840 ft) above sea level |
| Transit | 30.5 m (100 ft) below to 12,000 m (40,000 ft) above sea level |

CDE3994 Controller-Drive Tray Airflow and Heat Dissipation

Airflow goes from the front of the controller-drive tray to the rear of the controller-drive tray. Allow at least 76 cm (30 in.) of clearance in front of the controller-drive tray and at least 61 cm (24 in.) of clearance behind the controller-drive tray for service clearance, ventilation, and heat dissipation.

Airflow Through the CDE3994 Controller-Drive Tray – Front View

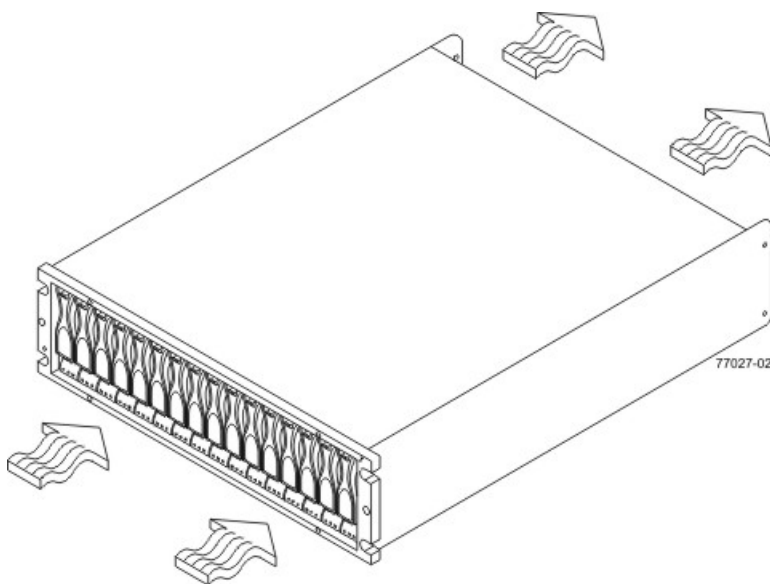

The tabulated power and heat dissipation values in the following table are the maximum measured operating power. Maximum configuration units are typically operated at high data rates or have larger random access memory (RAM) capabilities.

Power Ratings and Heat Dissipation for the CDE3994 Controller-Drive Tray

| Component | KVA | Watts (AC) | Btu/Hr | Amps (240 VAC) |
|-------------------------------|-------|------------|--------|----------------|
| CDE3994 controller-drive tray | 0.624 | 600 | 2047 | 2.50 |

CDE3994 Controller-Drive Tray Acoustic Noise

Sound Levels for the CDE3994 Controller-Drive Tray

| Measurement | Level |
|----------------|----------|
| Sound power | 6.5 bels |
| Sound pressure | 65 dBA |

CDE3994 Controller-Drive Tray Site Wiring and Power

The agency ratings for the CDE3994 controller-drive tray are 6.00 A at 100 VAC and 2.50 A at 240 VAC. These ratings are the overall maximum AC currents for this system.

The CDE3994 controller-drive tray uses wide-ranging, redundant power supplies that automatically accommodate voltages to the AC power source or the optional –48-VDC power source. The power supplies meet standard voltage requirements for both North American (USA and Canada) operation and worldwide (except USA and Canada) operation. The power supplies use standard industrial wiring with line-to-neutral or line-to-line power connections.

 **NOTE** Power for the optional –48-VDC power configuration is supplied by a centralized DC power plant instead of the AC power source in the cabinet. Refer to the associated manufacturer's documentation for specific DC power source requirements.

Keep this information in mind when you prepare the installation site for the controller-drive tray:

- **Protective ground** – Site wiring must include a protective ground connection to the AC power source or the optional –48-VDC power source.

 **NOTE** *Protective ground* is also known as safety ground or chassis ground.

- **Circuit overloading** – Power circuits and associated circuit breakers must provide enough power and overload protection. To prevent damage to the controller-drive tray, isolate its power source from large switching loads, such as air-conditioning motors, elevator motors, and factory loads.
- **Power interruptions** – The controller-drive tray can withstand these applied voltage interruptions:
 - **Input transient** – 50 percent of the nominal voltage
 - **Duration** – One-half cycle
 - **Maximum frequency** – Once every 10 seconds
- **Power failures** – If a total power failure occurs, the controller-drive tray automatically performs a power-on recovery sequence without operator intervention after the power is restored.

 **NOTE** When a power failure occurs, the controller-drive tray uses battery power to back up the data that is in cache.

If you are installing a large storage system configuration, you must make sure that you are supplying the correct AC source voltages, and not creating an over-current situation.

CDE3994 Controller-Drive Tray Power Input

AC Power Input

Each power supply contains one 15-A slow-blow fuse.

AC Power Requirements for the CDE3994 Controller-Drive Tray

| Parameter | Low Range | High Range |
|---|-------------|-------------|
| Nominal voltage | 115 VAC | 230 VAC |
| Frequency | 50 to 60 Hz | 50 to 60 Hz |
| Idle current | 3.81 A* | 1.98 A** |
| Maximum operating current | 3.96 A* | 2.06 A** |
| Maximum surge current | 5.52 A* | 2.72 A** |
| *Typical current: 115 VAC, 60 Hz at 0.77 power supply efficiency and 0.96 power factor. **Typical current: 230 VAC, 60 Hz at 0.77 power supply efficiency and 0.96 power factor. | | |

DC Power Input

Nominal input voltages for the DC power source are as follows:

- Low range: -36 VDC
- High range: -72 VDC

The maximum operating current is 17 A.

CDE3994 Controller-Drive Tray Power Factor Correction

Power factor correction is applied within the power-fan canister of each CDE3994 controller-drive tray, which maintains the power factor of the controller-drive tray at greater than 0.96 with nominal input voltage.

CDE3994 Controller-Drive Tray AC Power Cords and Receptacles

Each CDE3994 controller-drive tray is shipped with two AC power cords, which fit the standard AC outlets in the destination country. Each AC power cord connects one of the power-fan canisters in the controller-drive tray to an independent, external AC power source, such as a wall receptacle or an uninterruptible power supply (UPS).

DC power is an option that is available for use with your controller-drive tray and drive tray. For more information, refer to "[CDE3994 Controller-Drive Tray Optional DC Power Connector Cables and Source Wires.](#)"

If you have a cabinet with internal power cabling, such as a ladder cord, you do not need the AC power cords that are shipped with the controller-drive tray.

CDE3994 Controller-Drive Tray Optional DC Power Connector Cables and Source Wires

The CDE3994 controller-drive tray is shipped with –48-VDC power connector cables if the DC power option is ordered. The –48-VDC power connector cable plugs into the DC power connector on the rear of the controller-drive tray. The three source wires on the other end of the power connector cable connect the controller-drive tray to centralized DC power plant equipment, typically through a bus bar above the cabinet.

WARNING (W12) Risk of electrical shock – This unit has more than one power source. To remove all power from the unit, all DC MAINS must be disconnected by removing all power connectors (item 4 below) from the power supplies.

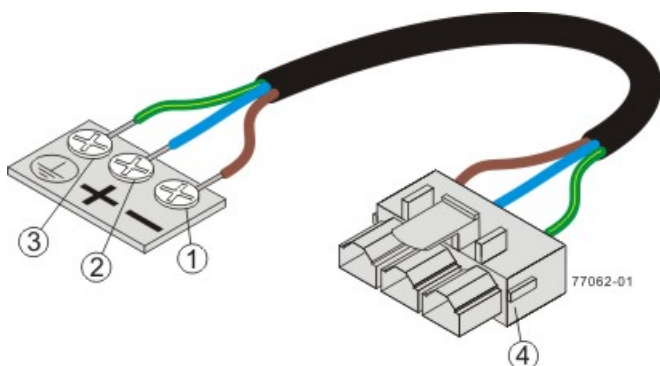

1. Supply (Negative), Brown Wire, –48 VDC
2. Return (Positive), Blue Wire
3. Ground, Green and Yellow Wire
4. DC Power Connector

WARNING (W14) Risk of bodily injury – A qualified service person is required to make the DC power connection according to NEC and CEC guidelines.

Two (or, optionally, four) DC power connector cables are provided with each controller-drive tray. Two DC power connectors are on the two DC power supplies on the rear of each controller-drive tray if additional redundancy is required.

NOTE It is not mandatory that you connect the second DC power connection on the DC power supplies of the controller-drive tray. The second DC power connection is provided for additional redundancy only and can be connected to a second DC power bus.

Preparing the Network for the Controllers

If you plan to use Ethernet connections from the storage management station to the controllers, you will use the out-of-band management method. For this configuration, meet with your network administrator before you order and install the equipment so that you can prepare for the setup and management of the devices on the IP network. Each controller uses its Ethernet management ports to connect to the IP network and communicate with the other devices on the IP network (often requiring a special application to set up the protocol).

Your network administrator can pre-assign the addresses that you need to manage the communication between the devices on the IP network. Depending on your storage configuration, you will need the following addresses:

- Up to two network IP addresses for each controller
- Up to two subnet mask addresses for each controller
- Either two IPv4 addresses (one static and one dynamic) or one IPv6 address for each controller
- A Dynamic Host Configuration Protocol (DHCP) address for each controller

If switches are used in your storage environment, you must know if zoning will be used, and how it will be configured.

Specifications of the AM1331 and AM1333 Controller-Drive Trays

The AM1331 and AM1333 controller-drive trays are available in rackmount models.

AM1331 and AM1333 Controller-Drive Trays – Front View

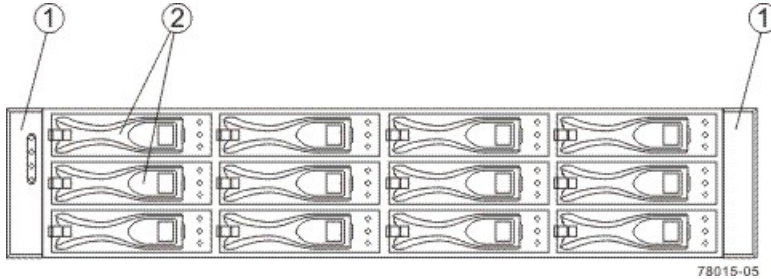

1. End Caps (the Left End Cap Has the Controller-Drive Tray Summary LEDs)
2. Drives

AM1331 Controller-Drive Tray – Rear View

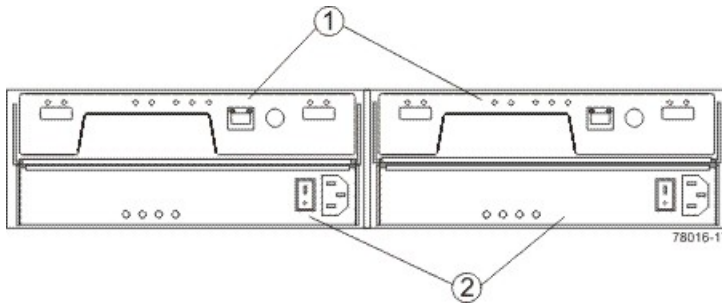

1. Controller Canisters
2. Power-Fan Canisters

AM1333 Controller-Drive Tray – Rear View

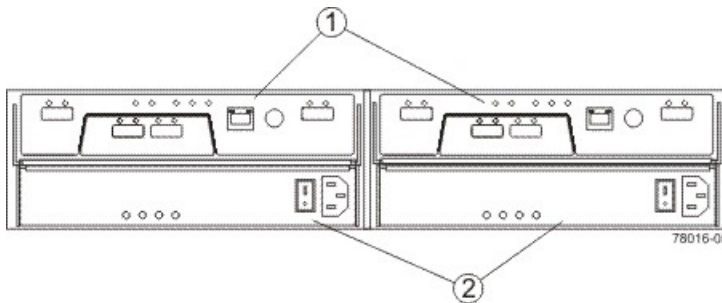

1. Controller Canisters
2. Power-Fan Canisters

Usually, an AC power source supplies power to the power-fan canister. A DC power option is also available.

AM1333 Controller-Drive Tray – Power Source Options Rear View

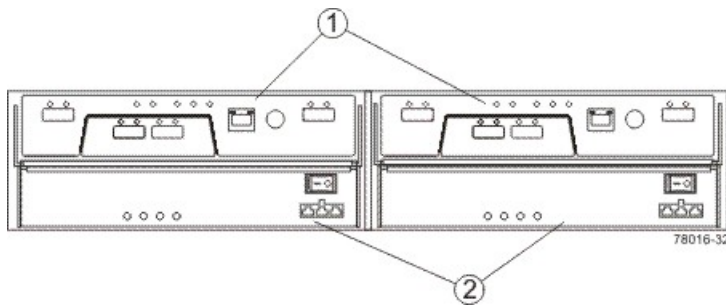

1. Controller Canisters
2. DC Power Switch on an Optional Power-Fan Canister

AM1331 and AM1333 Controller-Drive Tray Dimensions

The AM1331 and AM1333 controller-drive tray conforms to the 48.3-cm (19.0-in.) rack standard.

Dimensions of the AM1331 and AM1333 Controller-Drive Tray – Front View

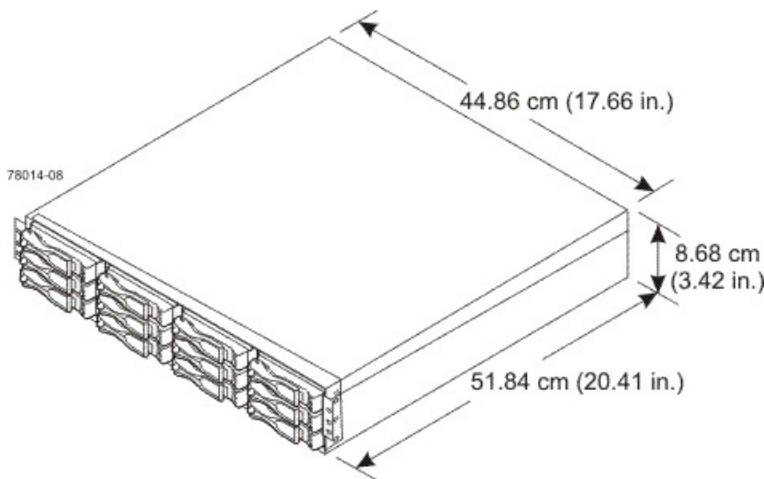

AM1331 and AM1333 Controller-Drive Trays Weight

Weights of the AM1331 and AM1333 Controller-Drive Trays

| Unit | Weight | | |
|--|------------------|-----------------|--------------------|
| | Maximum* | Empty** | Shipping*** |
| AM1331 and AM1333 controller-drive trays | 25.86 kg (57 lb) | 6.80 kg (15 lb) | 25.00 kg (55.0 lb) |

*Maximum weight indicates a controller-drive tray with all of its drives and other components installed. Because drive weights can vary greatly, this value can vary from the value specified as much as 0.3 kg (0.6 lb) times the maximum number of drives per controller-drive tray for drives weighing 1.0 kg (2.2 lb).

**Empty weight indicates a controller-drive tray with the controller canisters, the power-fan canisters, and the drives removed.

| Unit | Weight | | |
|---|----------|---------|-------------|
| | Maximum* | Empty** | Shipping*** |
| ***Shipping weight indicates the maximum weight of the controller-drive tray and all shipping material. | | | |

Component Weights of the AM1331 and AM1333 Controller-Drive Trays

| Component | Weight |
|--------------------|--------------------|
| ESM canister | 0.907 kg (2.00 lb) |
| Power-fan canister | 2.267 kg (5.00 lb) |
| Drive | 1.0 kg (2.2 lb) |

AM1331 and AM1333 Controller-Drive Trays Shipping Dimensions

Shipping Carton Dimensions for the AM1331 and AM1333 Controller-Drive Trays

| Height | Width | Depth |
|--------------------|----------------------|----------------------|
| 8.68 cm (3.42 in.) | 51.84 cm (20.41 in.) | 44.86 cm (17.66 in.) |

AM1331 and AM1333 Controller-Drive Trays Temperature and Humidity

Temperature Requirements and Humidity Requirements for the AM1331 and AM1333 Controller-Drive Trays

| Condition | Parameter | Requirement |
|-------------------------------------|------------------------|---|
| Temperature* | Operating range | 10°C to 35°C (50°F to 95°F) |
| | Maximum rate of change | 10°C (18°F) per hour |
| | Storage range | -10°C to 45°C (14°F to 113°F) |
| | Maximum rate of change | 15°C (27°F) per hour |
| | Transit range | -20°C to 60°C (-40°F to 149°F) for one week |
| | Maximum rate of change | 20°C (36°F) per hour |
| Relative humidity (no condensation) | Operating range | 20% to 80% |
| | Storage range | 10% to 90% |
| | Transit range | 5% to 95% |

| Condition | Parameter | Requirement |
|--|-------------------|--------------|
| | Maximum dew point | 26°C (79°F) |
| | Maximum gradient | 10% per hour |
| *If you plan to operate a system at an altitude between 1000 m to 3000 m (3280 ft to 9842 ft) above sea level, lower the environmental temperature 1.7°C (3.3°F) for every 1000 m (3280 ft) above sea level. | | |

AM1331 and AM1333 Controller-Drive Trays Altitude Ranges

Altitude Ranges for the AM1331 and AM1333 Controller-Drive Trays

| Environment | Altitude |
|-------------|---|
| Operating | 30.5 m (100 ft) below sea level to 3000 m (9842 ft) above sea level |
| Storage | 30.5 m (100 ft) below sea level to 3000 m (9842 ft) above sea level |
| Transit | 30.5 m (100 ft) below sea level to 12,000 m (40,000 ft) above sea level |

AM1331 and AM1333 Controller-Drive Trays Airflow and Heat Dissipation

Allow at least 76 cm (30 in.) of clearance in front of the controller-drive tray and 61 cm (24 in.) behind the controller-drive tray for service clearance, ventilation, and heat dissipation.

Airflow Through the AM1331 and AM1333 Controller-Drive Trays – Front View

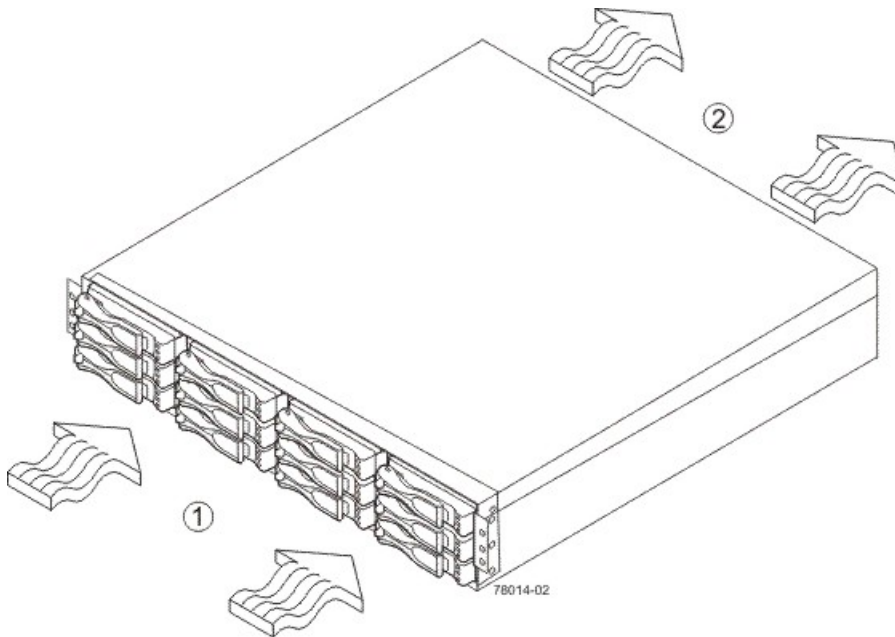

1. 76 cm (30 in.) clearance in front of the cabinet
2. 61 cm (24 in.) clearance behind the cabinet

Power and Heat Dissipation for the AM1331 and AM1333 Controller-Drive Trays

| Component | KVA | Watts (AC) | Btu/Hr |
|---------------------|-------|------------|--------|
| Controller canister | 0.398 | 394 | 1346 |

AM1331 and AM1333 Controller-Drive Trays Acoustic Noise

Sound Levels for the AM1331 and AM1333 Controller-Drive Trays

| Measurement | Level |
|---------------------------------|-----------------|
| ES 2-10-02 Standard Level 2 | 0.5 bels margin |
| Sound power (standby operation) | 6.5 bels |
| Sound power (normal operation) | 6.8 bels |

AM1331 and AM1333 Controller-Drive Trays Site Wiring and Power

The AM1331 and AM1333 controller-drive trays use wide-ranging, redundant power supplies that automatically accommodate voltages to the AC power source. The power supplies meet standard voltage requirements for both North American (USA and Canada) operation and worldwide (except USA and Canada) operation. The power supplies use standard industrial wiring with line-to-neutral or line-to-line power connections.

Keep this information in mind when you prepare the installation site for the controller-drive tray:

- **Protective ground** – Site wiring must include a protective ground connection to the AC power source.



NOTE *Protective ground* is also known as safety ground or chassis ground.

- **Circuit overloading** – Power circuits and associated circuit breakers must provide enough power and overload protection. To prevent damage to the controller-drive tray, isolate its power source from large switching loads, such as air-conditioning motors, elevator motors, and factory loads.
- **Power interruptions** – The controller-drive tray can withstand these applied voltage interruptions:
 - **Input transient** – 50 percent of the nominal voltage
 - **Duration** – One-half cycle
 - **Frequency** – Once every 10 seconds
- **Power failures** – If a total power failure occurs, the controller-drive tray automatically performs a power-on recovery sequence without operator intervention.

AM1331 and AM1333 Controller-Drive Trays Power Input

AC Power Input

Each power supply contains one 10-A slow-blow fuse.

AC Power Requirements for the AM1331 and AM1333 Controller-Drive Trays

| Parameter | Low Range | High Range |
|--|------------------|-----------------|
| Nominal voltage | 100 VAC | 240 VAC |
| Frequency | 50 to 60 Hz | 50 to 60 Hz |
| Idle current | 3.140 A–3.750 A* | 1.34 A–1.58 A** |
| Maximum operating current | 4.01 A–4.08 A* | 1.69 A–1.70 A** |
| <p>*Typical voltage: 100 VAC, 60 Hz at 0.77 power supply efficiency and 0.96 power factor. The range provided shows that these numbers can vary significantly, depending upon the drives tested in the particular configuration.</p> <p>**Typical voltage: 240 VAC, 50 Hz at 0.77 power supply efficiency and 0.96 power factor. The range provided shows that these numbers can vary significantly, depending upon the drives tested in the particular configuration.</p> | | |

DC Power Input

Nominal input voltages for the DC power source are as follows:

- Low range: –36 VDC
- High range: –72 VDC

The maximum operating current is 17 A.

AM1331 and AM1333 Controller-Drive Trays Power Factor Correction

Power factor correction is applied within the power supply, which maintains the power factor of the controller-drive tray at greater than 0.95 with nominal input voltage.

AM1331 and AM1333 Controller-Drive Trays AC Power Cords and Receptacles

Each AM1331 and AM1333 controller-drive tray is shipped with two AC power cords. Each AC power cord connects one of the power supplies in a controller-drive tray to an independent, external AC power source, such as a wall receptacle or a UPS.

DC power is an option that is available for use with your controller-drive tray and drive tray. For more information, see [“AM1331 and AM1333 Controller-Drive Trays Optional DC Power Connector Cables and Source Wires.”](#)

If you have a cabinet with internal power cabling, such as a ladder cord, you do not need the AC power cords that are shipped with the controller-drive tray.

AM1331 and AM1333 Controller-Drive Trays Optional DC Power Connector Cables and Source Wires

The AM1331 and AM1333 controller-drive trays are shipped with –48-VDC power connector cables if the DC power option is ordered. The –48-VDC power connector cable plugs into the DC power connector on the rear of the controller-drive tray. The three source wires on the other end of the power connector cable connect the controller-drive tray to centralized DC power plant equipment, typically through a bus bar above the cabinet.

⚠ WARNING (W12) Risk of electrical shock – This unit has more than one power source. To remove all power from the unit, all DC MAINS must be disconnected by removing all power connectors (item 4 below) from the power supplies.

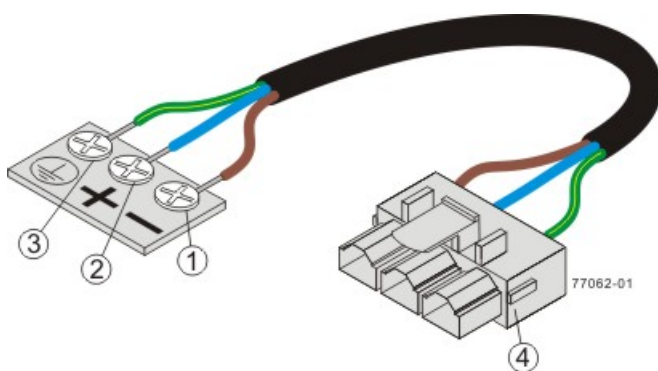

1. Supply (Negative), Brown Wire, –48 VDC
2. Return (Positive), Blue Wire
3. Ground, Green and Yellow Wire
4. DC Power Connector

⚠ WARNING (W14) Risk of bodily injury – A qualified service person is required to make the DC power connection according to NEC and CEC guidelines.

Two DC power connector cables are provided with each controller-drive tray. Two DC power connectors are on the two DC power supplies on the rear of each controller-drive tray if additional redundancy is required.



NOTE It is not mandatory that you connect the second DC power connection on the DC power supplies of the controller-drive tray. The second DC power connection is provided for additional redundancy only and can be connected to a second DC power bus.

Preparing the Network for the Controllers

If you plan to use Ethernet connections from the storage management station to the controllers, you will use the out-of-band management method. For this configuration, meet with your network administrator before you order and install the equipment so that you can prepare for the setup and management of the devices on the IP network. Each controller uses its Ethernet management ports to connect to the IP network and communicate with the other devices on the IP network (often requiring a special application to set up the protocol).

Your network administrator can pre-assign the addresses that you need to manage the communication between the devices on the IP network. Depending on your storage configuration, you will need the following addresses:

- Up to two network IP addresses for each controller
- Up to two subnet mask addresses for each controller
- Either two IPv4 addresses (one static and one dynamic) or one IPv6 address for each controller
- A Dynamic Host Configuration Protocol (DHCP) address for each controller

If switches are used in your storage environment, you must know if zoning will be used, and how it will be configured.

Specifications of the AM1532 Controller-Drive Tray

The AM1532 controller-drive tray is available in a rackmount model.

AM1532 Controller-Drive Tray – Front View

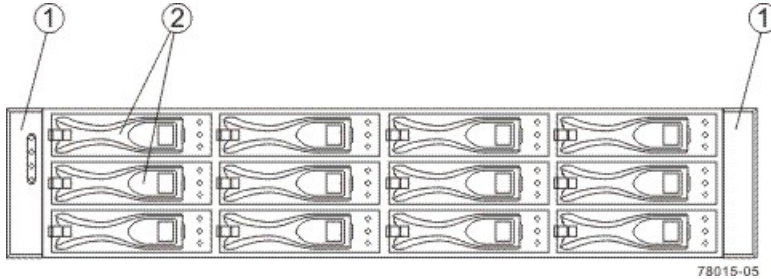

1. End Caps (the Left End Cap Has the Controller-Drive Tray Summary LEDs)
2. Drives

Usually, an AC power source supplies power to the power-fan canister. A DC power option is also available.

AM1532 Controller-Drive Tray – Rear View

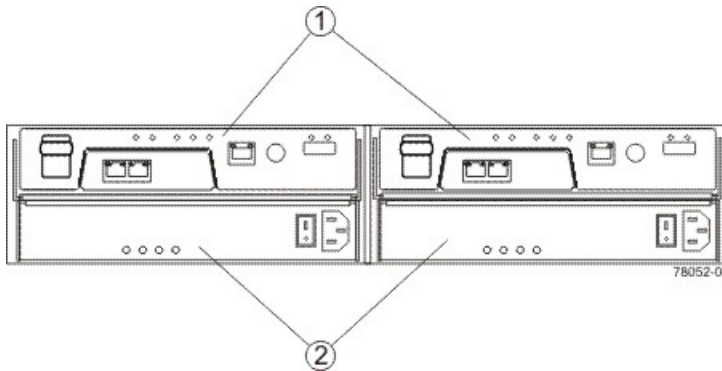

1. Controller Canisters
2. Power-Fan Canisters

AM1532 Controller-Drive Tray – Power Source Options Rear View

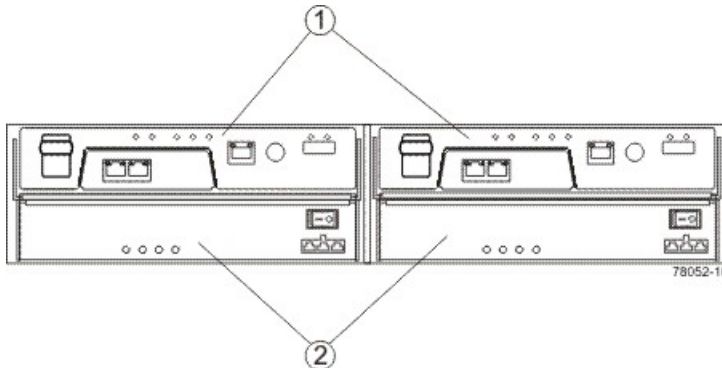

1. Controller Canisters
2. DC Power Switch on an Optional Power-Fan Canister

AM1532 Controller-Drive Tray Dimensions

The AM1532 controller-drive tray conforms to the 48.3-cm (19.0-in.) rack standard.

Dimensions of the AM1532 Controller-Drive Tray – Front View

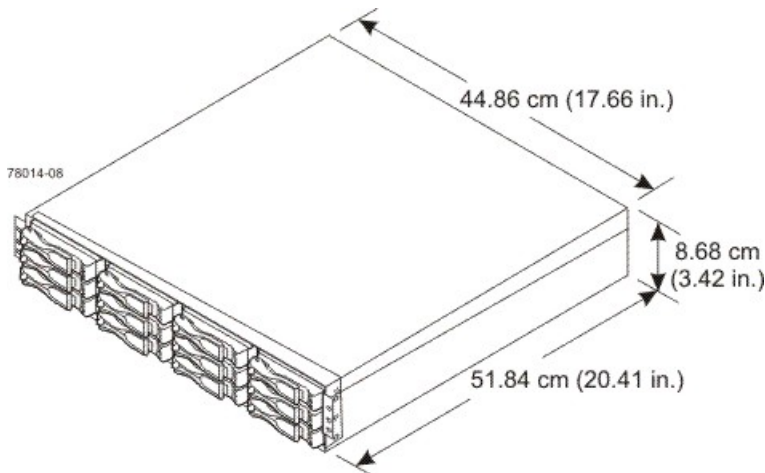

AM1532 Controller-Drive Tray Weight

Weights of the AM1532 Controller-Drive Tray

| Unit | Weight | | |
|--|------------------|-----------------|--------------------|
| | Maximum* | Empty** | Shipping*** |
| AM1532 controller-drive tray | 25.86 kg (57 lb) | 6.80 kg (15 lb) | 25.00 kg (55.0 lb) |
| <p>*Maximum weight indicates a controller-drive tray with all of its drives and other components installed. Because drive weights can vary greatly, this value can vary from the value specified as much as 0.3 kg (0.6 lb) times the maximum number of drives per controller-drive tray for drives weighing 1.0 kg (2.2 lb).</p> <p>**Empty weight indicates a controller-drive tray with the controller canisters, the power-fan canisters, and the drives removed.</p> <p>***Shipping weight indicates the maximum weight of the controller-drive tray and all shipping material.</p> | | | |

Component Weights of the AM1532 Controller-Drive Tray

| Component | Weight |
|--------------------|--------------------|
| ESM canister | 0.907 kg (2.00 lb) |
| Power-fan canister | 2.267 kg (5.00 lb) |
| Drive | 1.0 kg (2.2 lb) |

AM1532 Controller-Drive Tray Shipping Dimensions

Shipping Carton Dimensions for the AM1532 Controller-Drive Tray

| Height | Width | Depth |
|--------------------|----------------------|----------------------|
| 8.68 cm (3.42 in.) | 51.84 cm (20.41 in.) | 44.86 cm (17.66 in.) |

AM1532 Controller-Drive Tray Temperature and Humidity

Temperature Requirements and Humidity Requirements for the AM1532 Controller-Drive Tray

| Condition | Parameter | Requirement |
|--|------------------------|---|
| Temperature | Operating range | 10°C to 35°C (50°F to 95°F) |
| | Maximum rate of change | 10°C (18°F) per hour |
| | Storage range | -10°C to 45°C (14°F to 113°F) |
| | Maximum rate of change | 15°C (27°F) per hour |
| | Transit range | -20°C to 60°C (-40°F to 140°F) for one week |
| | Maximum rate of change | 20°C (36°F) per hour |
| Relative humidity (no condensation) | Operating range | 20% to 80% |
| | Storage range | 10% to 90% |
| | Transit range | 5% to 95% |
| | Maximum dew point | 26°C (79°F) |
| | Maximum gradient | 10% per hour |
| *If you plan to operate a system at an altitude between 1000 m to 3000 m (3280 ft to 9842 ft) above sea level, lower the environmental temperature 1.7°C (3.3°F) for every 1000 m (3280 ft) above sea level. | | |

AM1532 Controller-Drive Tray Altitude Ranges

Altitude Ranges for the AM1532 Controller-Drive Tray

| Environment | Altitude |
|-------------|---|
| Operating | 30.5 m (100 ft) below sea level to 3000 m (9842 ft) above sea level |
| Storage | 30.5 m (100 ft) below sea level to 3000 m (9842 ft) above sea level |

| Environment | Altitude |
|-------------|---|
| Transit | 30.5 m (100 ft) below sea level to 12,000 m (40,000 ft) above sea level |

AM1532 Controller-Drive Tray Airflow and Heat Dissipation

Allow at least 76 cm (30 in.) of clearance in front of the controller-drive tray and 61 cm (24 in.) behind the controller-drive tray for service clearance, ventilation, and heat dissipation.

Airflow Through the AM1532 Controller-Drive Tray – Front View

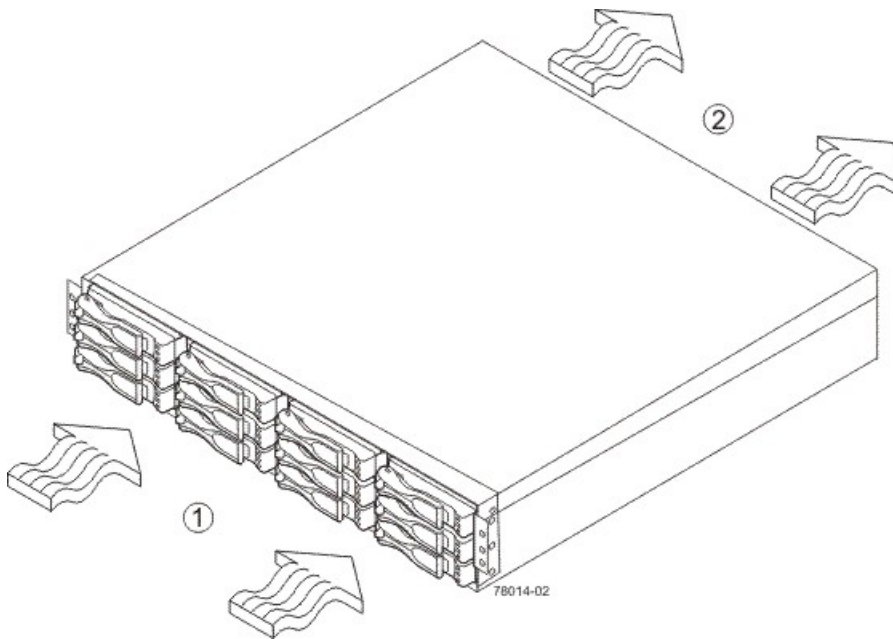

1. 76 cm (30 in.) clearance in front of the cabinet
2. 61 cm (24 in.) clearance behind the cabinet

Power and Heat Dissipation for the AM1532 Controller-Drive Tray

| Component | KVA | Watts (AC) | Btu/Hr |
|---------------------|-------|------------|--------|
| Controller canister | 0.458 | 453 | 1548 |

AM1532 Controller-Drive Tray Acoustic Noise

Sound Levels for the AM1532 Controller-Drive Tray

| Measurement | Level |
|---------------------------------|-----------------|
| ES 2-10-02 Standard Level 2 | 0.5 bels margin |
| Sound power (standby operation) | 6.5 bels |

| Measurement | Level |
|--------------------------------|----------|
| Sound power (normal operation) | 6.8 bels |

AM1532 Controller-Drive Tray Site Wiring and Power

The AM1532 controller-drive tray uses wide-ranging, redundant power supplies that automatically accommodate voltages to the AC power source. The power supplies meet standard voltage requirements for both North American (USA and Canada) operation and worldwide (except USA and Canada) operation. The power supplies use standard industrial wiring with line-to-neutral or line-to-line power connections.

Keep this information in mind when you prepare the installation site for the controller-drive tray:

- **Protective ground** – Site wiring must include a protective ground connection to the AC power source.



NOTE *Protective ground* is also known as safety ground or chassis ground.

- **Circuit overloading** – Power circuits and associated circuit breakers must provide enough power and overload protection. To prevent damage to the controller-drive tray, isolate its power source from large switching loads, such as air-conditioning motors, elevator motors, and factory loads.
- **Power interruptions** – The controller-drive tray can withstand these applied voltage interruptions:
 - **Input transient** – 50 percent of the nominal voltage
 - **Duration** – One-half cycle
 - **Frequency** – Once every 10 seconds
- **Power failures** – If a total power failure occurs, the controller-drive tray automatically performs a power-on recovery sequence without operator intervention.

AM1532 Controller-Drive Tray Power Input

AC Power Input

Each power supply contains one 10-A slow-blow fuse.

AC Power Requirements for the AM1532 Controller-Drive Tray

| Parameter | Low Range | High Range |
|--|-------------|-------------|
| Nominal voltage | 100 VAC | 240 VAC |
| Frequency | 50 to 60 Hz | 50 to 60 Hz |
| Idle current | 3.96 A* | 1.74 A** |
| Maximum operating current | 4.08 A* | 1.70 A** |
| <p>*Typical current: 100 VAC, 60 Hz at 0.77 power supply efficiency and 0.96 power factor. These numbers can vary significantly, depending upon the drives tested in the particular configuration.</p> <p>**Typical current: 240 VAC, 60 Hz at 0.77 power supply efficiency and 0.96 power factor. These numbers can vary significantly, depending upon the drives tested in the particular configuration.</p> | | |

DC Power Input

Nominal input voltages for the DC power source are as follows:

- Low range: –36 VDC
- High range: –72 VDC

The maximum operating current is 17 A.

AM1532 Controller-Drive Tray Power Factor Correction

Power factor correction is applied within the power supply, which maintains the power factor of the controller-drive tray at greater than 0.95 with nominal input voltage.

AM1532 Controller-Drive Tray AC Power Cords and Receptacles

Each AM1532 controller-drive tray is shipped with two AC power cords. Each AC power cord connects one of the power supplies in a controller-drive tray to an independent, external AC power source, such as a wall receptacle or a UPS.

DC power is an option that is available for use with your controller-drive tray and drive tray. For more information, see “[AM1532 Controller-Drive Tray Optional DC Power Connector Cables and Source Wires.](#)”

If you have a cabinet with internal power cabling, such as a ladder cord, you do not need the AC power cords that are shipped with the controller-drive tray.

AM1532 Controller-Drive Tray Optional DC Power Connector Cables and Source Wires

The AM1532 controller-drive tray is shipped with –48-VDC power connector cables if the DC power option is ordered. The –48-VDC power connector cable plugs into the DC power connector on the rear of the controller-drive tray. The three source wires on the other end of the power connector cable connect the controller-drive tray to centralized DC power plant equipment, typically through a bus bar above the cabinet.



WARNING (W12) Risk of electrical shock – This unit has more than one power source. To remove all power from the unit, all DC MAINS must be disconnected by removing all power connectors (item 4 below) from the power supplies.

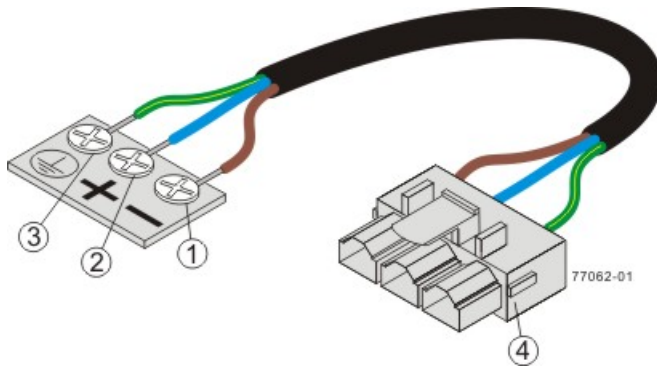

1. Supply (Negative), Brown Wire, -48 VDC
2. Return (Positive), Blue Wire
3. Ground, Green and Yellow Wire
4. DC Power Connector



WARNING (W14) Risk of bodily injury – A qualified service person is required to make the DC power connection according to NEC and CEC guidelines.

Two DC power connector cables are provided with each controller-drive tray. Two DC power connectors are on the two DC power supplies on the rear of each controller-drive tray if additional redundancy is required.



NOTE It is not mandatory that you connect the second DC power connection on the DC power supplies of the controller-drive tray. The second DC power connection is provided for additional redundancy only and can be connected to a second DC power bus.

Preparing the Network for the Controllers

If you plan to use Ethernet connections from the storage management station to the controllers, you will use the out-of-band management method. For this configuration, meet with your network administrator before you order and install the equipment so that you can prepare for the setup and management of the devices on the IP network. Each controller uses its Ethernet management ports to connect to the IP network and communicate with the other devices on the IP network (often requiring a special application to set up the protocol).

Your network administrator can pre-assign the addresses that you need to manage the communication between the devices on the IP network. Depending on your storage configuration, you will need the following addresses:

- Up to two network IP addresses for each controller
- Up to two subnet mask addresses for each controller
- Either two IPv4 addresses (one static and one dynamic) or one IPv6 address for each controller
- A Dynamic Host Configuration Protocol (DHCP) address for each controller

If switches are used in your storage environment, you must know if zoning will be used, and how it will be configured.

Specifications of the AM1932 Controller-Drive Tray

The AM1932 controller-drive tray is available in a rackmount model.

AM1932 Controller-Drive Tray – Front View

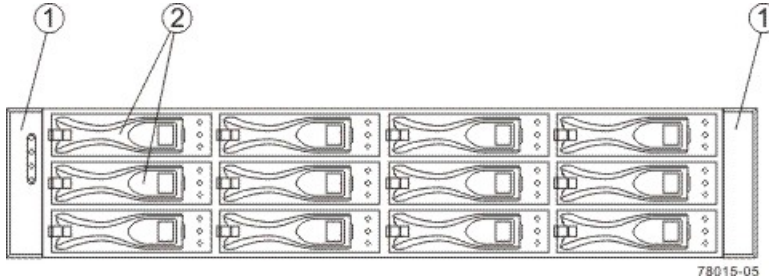

1. End Caps (the Left End Cap Has the Controller-Drive Tray Summary LEDs)
2. Drives

AM1932 Controller-Drive Tray – Rear View

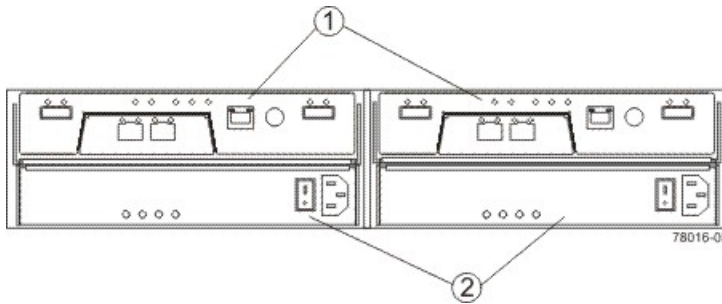

1. Controller Canisters
2. Power-Fan Canisters

Usually, an AC power source supplies power to the power-fan canister. A DC power option is also available.

AM1932 Controller-Drive Tray – Power Source Options Rear View

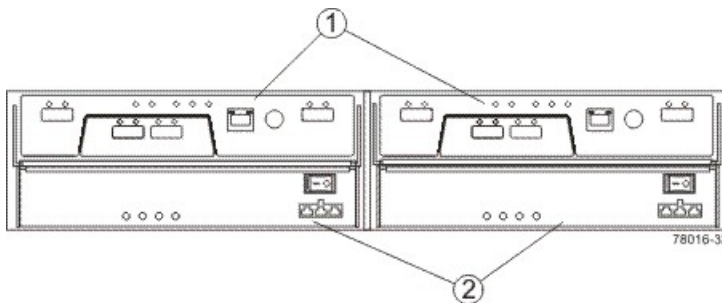

1. Controller Canisters
2. DC Power Switch on an Optional Power-Fan Canister

AM1932 Controller-Drive Tray Dimensions

The AM1932 controller-drive tray conforms to the 48.3-cm (19.0-in.) rack standard.

Dimensions of the AM1932 Controller-Drive Tray – Front View

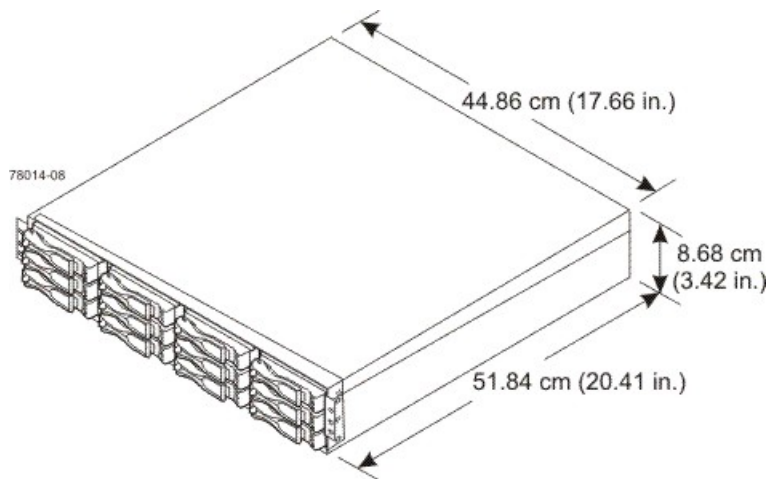

AM1932 Controller-Drive Tray Weight

Weights of the AM1932 Controller-Drive Tray

| Unit | Weight | | |
|------------------------------|------------------|-----------------|--------------------|
| | Maximum* | Empty** | Shipping*** |
| AM1932 controller-drive tray | 25.86 kg (57 lb) | 6.80 kg (15 lb) | 25.00 kg (55.0 lb) |

*Maximum weight indicates a controller-drive tray with all of its drives and other components installed. Because drive weights can vary greatly, this value can vary from the value specified as much as 0.3 kg (0.6 lb) times the maximum number of drives per controller-drive tray for drives weighing 1.0 kg (2.2 lb).

**Empty weight indicates a controller-drive tray with the controller canisters, the power-fan canisters, and the drives removed.

***Shipping weight indicates the empty weight of a controller-drive tray and all shipping material.

Component Weights of the AM1932 Controller-Drive Tray

| Component | Weight |
|--------------------|--------------------|
| ESM canister | 0.907 kg (2.00 lb) |
| Power-fan canister | 2.267 kg (5.00 lb) |
| Drive | 1.0 kg (2.2 lb) |

AM1932 Controller-Drive Tray Shipping Dimensions

Shipping Carton Dimensions for the AM1932 Controller-Drive Tray

| Height | Width | Depth |
|--------------------|----------------------|----------------------|
| 8.68 cm (3.42 in.) | 51.84 cm (20.41 in.) | 44.86 cm (17.66 in.) |

AM1932 Controller-Drive Tray Temperature and Humidity

Temperature Requirements and Humidity Requirements for the AM1932 Controller-Drive Tray

| Condition | Parameter | Requirement |
|--|------------------------|--------------------------------|
| Temperature* | Operating range | 10°C to 35°C (50°F to 95°F) |
| | Maximum rate of change | 10°C (18°F) per hour |
| | Storage range | -10°C to 45°C (14°F to 113°F) |
| | Maximum rate of change | 15°C (27°F) per hour |
| | Transit range | -20°C to 60°C (-40°F to 140°F) |
| | Maximum rate of change | 20°C (36°F) per hour |
| Relative humidity (no condensation) | Operating range | 20% to 80% |
| | Storage range | 10% to 90% |
| | Transit range | 5% to 95% |
| | Maximum dew point | 26°C (79°F) |
| | Maximum gradient | 10% per hour |
| *If you plan to operate a system at an altitude between 1000 m to 3000 m (3280 ft to 9842 ft) above sea level, lower the environmental temperature 1.7°C (3.3°F) for every 1000 m (3280 ft) above sea level. | | |

AM1932 Controller-Drive Tray Altitude Ranges

Altitude Ranges for the AM1932 Controller-Drive Tray

| Environment | Altitude |
|-------------|---|
| Operating | 30.5 m (100 ft) below sea level to 3000 m (9842 ft) above sea level |
| Storage | 30.5 m (100 ft) below sea level to 3000 m (9842 ft) above sea level |

| Environment | Altitude |
|-------------|---|
| Transit | 30.5 m (100 ft) below sea level to 12,000 m (40,000 ft) above sea level |

AM1932 Controller-Drive Tray Airflow and Heat Dissipation

Allow at least 76 cm (30 in.) of clearance in front of the controller-drive tray and 61 cm (24 in.) behind the controller-drive tray for service clearance, ventilation, and heat dissipation.

Airflow Through the AM1932 Controller-Drive Tray – Front View

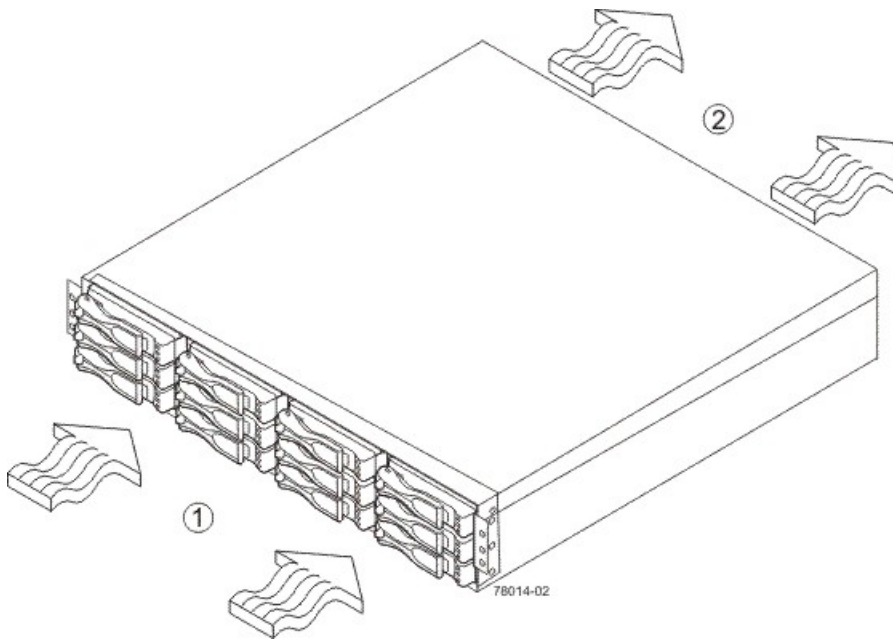

1. 76 cm (30 in.) clearance in front of the cabinet
2. 61 cm (24 in.) clearance behind the cabinet

Power and Heat Dissipation for the AM1932 Controller-Drive Tray

| Component | KVA | Watts (AC) | Btu/Hr |
|---------------------|-------|------------|--------|
| Controller canister | 0.458 | 453 | 1548 |

AM1932 Controller-Drive Tray Acoustic Noise

Sound Levels for the AM1932 Controller-Drive Tray

| Measurement | Level |
|---------------------------------|-----------------|
| ES 2-10-02 Standard Level 2 | 0.5 bels margin |
| Sound power (standby operation) | 6.5 bels |
| Sound power (normal operation) | 6.8 bels |

AM1932 Controller-Drive Tray Site Wiring and Power

The AM1932 controller-drive tray uses wide-ranging, redundant power supplies that automatically accommodate voltages to the AC power source. The power supplies meet standard voltage requirements for both North American (USA and Canada) operation and worldwide (except USA and Canada) operation. The power supplies use standard industrial wiring with line-to-neutral or line-to-line power connections.

Keep this information in mind when you prepare the installation site for the controller-drive tray:

- **Protective ground** – Site wiring must include a protective ground connection to the AC power source.



NOTE *Protective ground* is also known as safety ground or chassis ground.

- **Circuit overloading** – Power circuits and associated circuit breakers must provide enough power and overload protection. To prevent damage to the controller-drive tray, isolate its power source from large switching loads, such as air-conditioning motors, elevator motors, and factory loads.
- **Power interruptions** – The controller-drive tray can withstand these applied voltage interruptions:
 - **Input transient** – 50 percent of the nominal voltage
 - **Duration** – One-half cycle
 - **Frequency** – Once every 10 seconds
- **Power failures** – If a total power failure occurs, the controller-drive tray automatically performs a power-on recovery sequence without operator intervention.

AM1932 Controller-Drive Tray Power Input

AC Power Input

Each power supply contains one 10-A slow-blow fuse.

AC Power Requirements for the AM1932 Controller-Drive Tray

| Parameter | Low Range | High Range |
|--|----------------|-----------------|
| Nominal voltage | 100 VAC | 240 VAC |
| Frequency | 50 to 60 Hz | 50 to 60 Hz |
| Idle current | 2.90 A–3.96 A* | 1.25 A–1.74A** |
| Maximum operating current | 3.14 A–4.01 A* | 1.35 A–1.70 A** |
| <p>*Typical voltage: 100 VAC, 60 Hz at 0.77 power supply efficiency and 0.96 power factor. The range provided shows that these numbers can vary significantly, depending upon the drives tested in the particular configuration.</p> <p>**Typical voltage: 240 VAC, 50 Hz at 0.77 power supply efficiency and 0.96 power factor. The range provided shows that these numbers can vary significantly, depending upon the drives tested in the particular configuration.</p> | | |

DC Power Input

Nominal input voltages for the DC power source are as follows:

- Low range: –36 VDC
- High range: –72 VDC

The maximum operating current is 17 A.

AM1932 Controller-Drive Tray Power Factor Correction

Power factor correction is applied within the power supply, which maintains the power factor of the controller-drive tray at greater than 0.95 with nominal input voltage.

AM1932 Controller-Drive Tray AC Power Cords and Receptacles

Each AM1932 controller-drive tray is shipped with two AC power cords. Each AC power cord connects one of the power supplies in a controller-drive tray to an independent, external AC power source, such as a wall receptacle or a UPS.

DC power is an option that is available for use with your controller-drive tray and drive tray. For more information, see “[AM1932 Controller-Drive Tray Optional DC Power Connector Cables and Source Wires.](#)”

If you have a cabinet with internal power cabling, such as a ladder cord, you do not need the AC power cords that are shipped with the controller-drive tray.

AM1932 Controller-Drive Tray Optional DC Power Connector Cables and Source Wires

The AM1932 controller-drive tray is shipped with –48-VDC power connector cables if the DC power option is ordered. The –48-VDC power connector cable plugs into the DC power connector on the rear of the controller-drive tray. The three source wires on the other end of the power connector cable connect the controller-drive tray to centralized DC power plant equipment, typically through a bus bar above the cabinet.



WARNING (W12) Risk of electrical shock – This unit has more than one power source. To remove all power from the unit, all DC MAINS must be disconnected by removing all power connectors (item 4 below) from the power supplies.

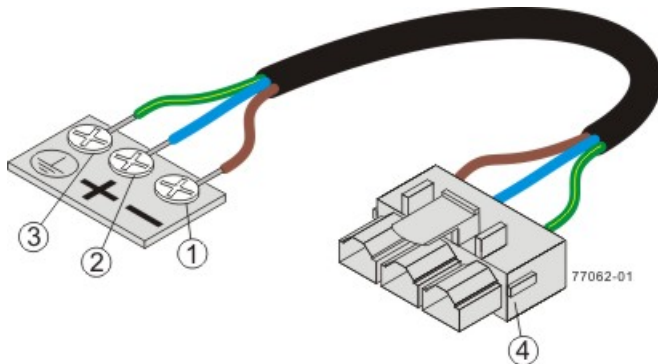

1. Supply (Negative), Brown Wire, -48 VDC
2. Return (Positive), Blue Wire
3. Ground, Green and Yellow Wire
4. DC Power Connector

WARNING (W14) Risk of bodily injury – A qualified service person is required to make the DC power connection according to NEC and CEC guidelines.

Two DC power connector cables are provided with each controller-drive tray. Two DC power connectors are on the two DC power supplies on the rear of each controller-drive tray if additional redundancy is required.

NOTE It is not mandatory that you connect the second DC power connection on the DC power supplies of the controller-drive tray. The second DC power connection is provided for additional redundancy only and can be connected to a second DC power bus.

Preparing the Network for the Controllers

If you plan to use Ethernet connections from the storage management station to the controllers, you will use the out-of-band management method. For this configuration, meet with your network administrator before you order and install the equipment so that you can prepare for the setup and management of the devices on the IP network. Each controller uses its Ethernet management ports to connect to the IP network and communicate with the other devices on the IP network (often requiring a special application to set up the protocol).

Your network administrator can pre-assign the addresses that you need to manage the communication between the devices on the IP network. Depending on your storage configuration, you will need the following addresses:

- Up to two network IP addresses for each controller
- Up to two subnet mask addresses for each controller
- Either two IPv4 addresses (one static and one dynamic) or one IPv6 address for each controller
- A Dynamic Host Configuration Protocol (DHCP) address for each controller

If switches are used in your storage environment, you must know if zoning will be used, and how it will be configured.

Specifications of the DE1600 Drive Tray

The DE1600 drive tray contains Serial Attached SCSI (SAS) drives. Each DE1600 drive tray contains these components:

- A maximum of 12 drives
- One or two power-supply fan canisters
- One or two environmental services monitor (ESM) canisters

DE1600 Drive Tray – Front View

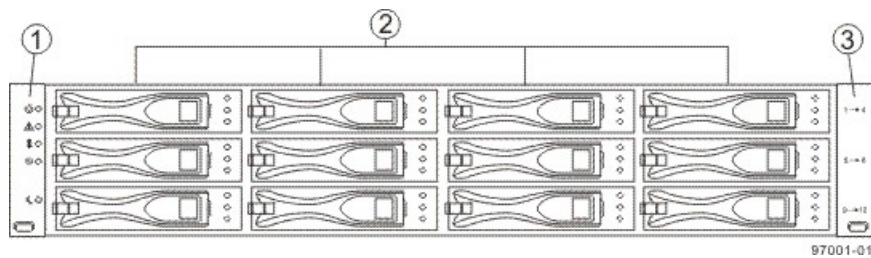

1. End Caps (the Left End Cap Has the Drive Tray LEDs)
2. Drives
3. Right End Cap

DE1600 Drive Tray – Rear View

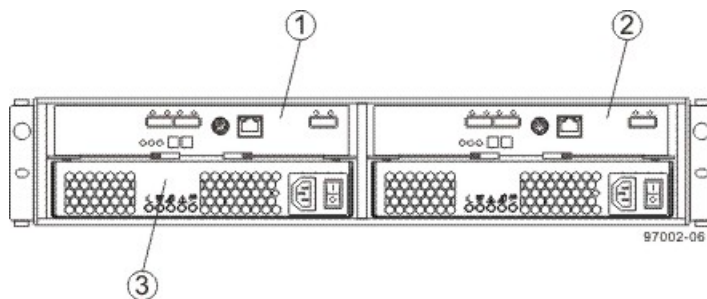

1. ESM A Canister
2. ESM B Canister
3. Power-Fan A Canister

Usually, an AC power source supplies power to the power-fan canister. A DC poweroption is also available.

DE1600 Drive Tray – Power Source Options Rear View

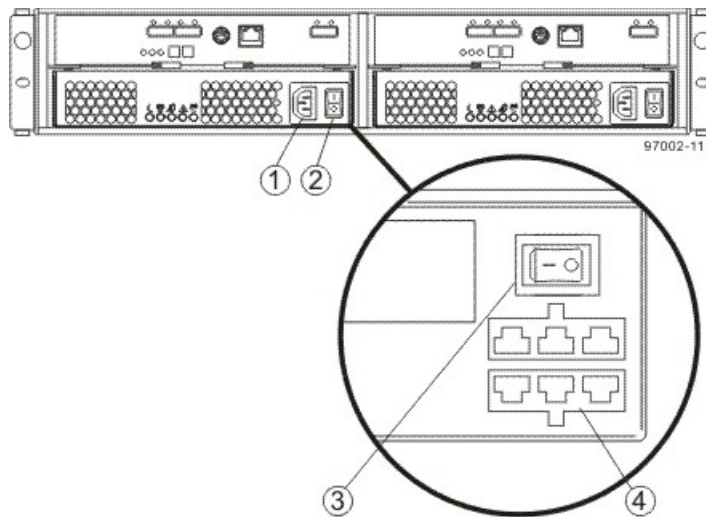

1. AC Power Connector on the AC Power-Fan Canister
2. AC Power Switch
3. DC Power Switch on an Optional DC Power-Fan Canister
4. Optional DC Power Connector and DC Power Switch

DE1600 Drive Tray Dimensions

Dimensions of the DE1600 Drive Tray – Front View

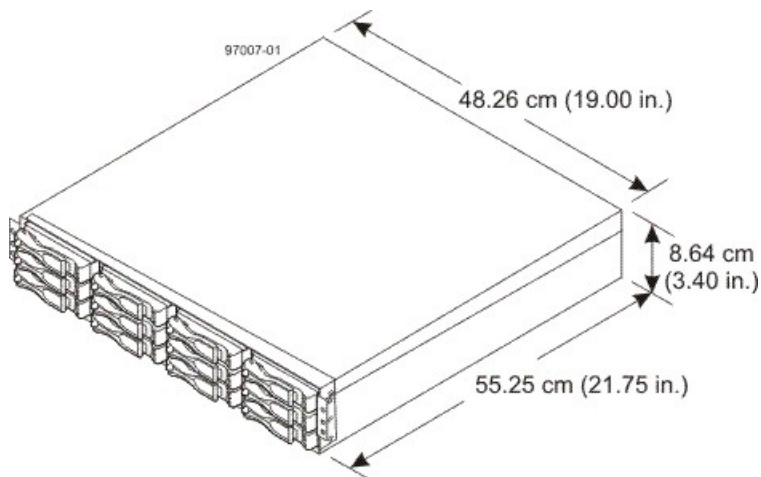

DE1600 Drive Tray Weight

Weights of the DE1600 Drive Tray

| Unit | Weight | | |
|-------------------|------------------|---------------------|--------------------|
| | Maximum* | Empty** | Shipping*** |
| DE1600 drive tray | 27 kg (59.52 lb) | 18.60 kg (41.01 lb) | 31.75 kg (70.0 lb) |

| Unit | Weight | | |
|--|----------|---------|-------------|
| | Maximum* | Empty** | Shipping*** |
| <p>*Maximum weight indicates a drive tray with all of its drives and other components installed. Because drive weights can vary greatly, this value can vary from the value specified as much as 0.3 kg (0.6 lb) times the maximum number of drives per drive tray for 3.5-in. SAS drives.</p> <p>**Empty weight indicates a drive tray with the ESM canisters, the power-fan canisters, and the drives removed.</p> <p>***Shipping weight indicates the maximum weight of a fully-populated drive tray and all shipping material.</p> | | | |

Component Weights of the DE1600 Drive Tray

| Component | Weight |
|--------------------|-------------------|
| ESM canister | 1.75 kg (3.86 lb) |
| Power-fan canister | 2.5 kg (5.51 lb) |
| 3.5-in. SAS drive | 1.00 kg (2.20 lb) |

DE1600 Drive Tray Shipping Dimensions

Drive Tray and Shipping Carton Dimensions for the DE1600 Drive Tray

| Height | Width | Depth |
|--------------------|----------------------|-------------------|
| 24.13 cm (9.5 in.) | 58.42 cm (23.00 in.) | 68.58 cm (27 in.) |

DE1600 Drive Tray Temperature and Humidity

Temperature Requirements and Humidity Requirements for the DE1600 Drive Tray

| Condition | Parameter | Requirement |
|-------------|--|--------------------------------|
| Temperature | Operating range (both cabinet and subsystem) | 10°C to 40°C (50°F to 104°F) |
| | Maximum rate of change | 10°C (50°F) per hour |
| | Storage range | -10°C to 50°C (14°F to 122°F) |
| | Maximum rate of change | 15°C (59°F) per hour |
| | Transit range | -40°C to 60°C (-40°F to 140°F) |
| | Maximum rate of change | 20°C (68°F) per hour |

| Condition | Parameter | Requirement |
|--|--|----------------------|
| Relative humidity (no condensation) | Operating range (both cabinet and subsystem) | 20% to 80% |
| | Storage range | 10% to 90% |
| | Transit range | 5% to 90% |
| | Operating gradient | 10°C (50°F) per hour |
| | Storage gradient | 15°C (59°F) per hour |
| | Transit gradient | 20°C (68°F) per hour |
| | Maximum dew point | 26°C (79°F) |
| | Maximum gradient | 10% per hour |
| *If you plan to operate a system at an altitude between 1000 m to 3000 m (3280 ft to 9842 ft) above sea level, lower the environmental temperature 1.7°C (3.3°F) for every 1000 m (3280 ft) above sea level. | | |

DE1600 Drive Tray Altitude Ranges

Altitude Ranges for the DE1600 Drive Tray

| Environment | Altitude |
|-------------|---|
| Operating | 30.5 m (100 ft) below sea level to 3000 m (9840 ft) above sea level |
| Storage | 30.5 m (100 ft) below sea level to 3000 m (9840 ft) above sea level |
| Transit | 30.5 m (100 ft) below sea level to 12,000 m (40,000 ft) above sea level |

DE1600 Drive Tray Airflow and Heat Dissipation

Airflow goes from the front of the drive tray to the rear of the drive tray. Allow at least 76 cm (30 in.) of clearance in front of the drive tray and at least 61 cm (24 in.) of clearance behind the drive tray for service clearance, ventilation, and heat dissipation.

Airflow Through the DE1600 Drive Tray – Front View

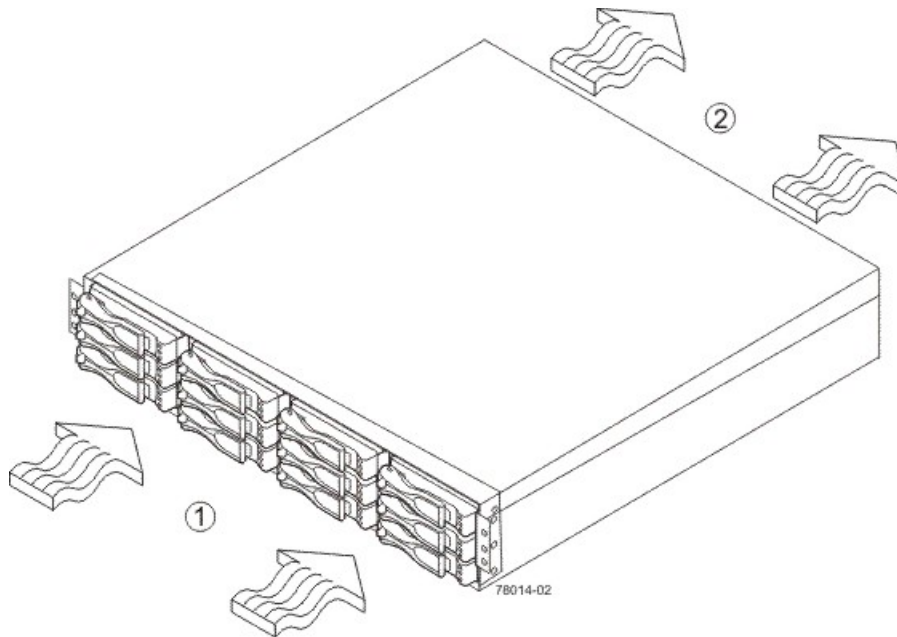

1. 76 cm (30 in.) clearance in front of the cabinet
2. 61 cm (24 in.) clearance behind the cabinet

The tabulated power and heat dissipation values in the following table are the maximum measured operating power.

Power Ratings and Heat Dissipation for the DE1600 Drive Tray

| Unit | KVA | AC Watts | Btu/Hr |
|-------------------|-------|----------|--------|
| DE1600 drive tray | 0.276 | 276 | 945 |

DE1600 Drive Tray Acoustic Noise

Acoustic Noise at 25°C for the DE1600 Drive Tray

| Measurement | Level |
|---------------------------------|------------------|
| Sound power (standby operation) | 6.5 bels maximum |
| Sound power (normal operation) | 6.8 bels maximum |

DE1600 Drive Tray Site Wiring and Power

The DE1600 drive tray uses wide-ranging, redundant power supplies that automatically accommodate voltages to the AC power source or the optional –48-VDC power source. The power supplies meet standard voltage requirements for both North American (USA and Canada) operation and worldwide (except USA and Canada) operation. The power supplies use standard industrial wiring with line-to-neutral or line-to-line power connections.

 **NOTE** Power for the optional –48-VDC power configuration is supplied by a centralized DC power plant instead of the AC power source in the cabinet. Refer to the associated manufacturer’s documentation for specific DC power source requirements.

Keep this information in mind when preparing the installation site for the drive tray:

- **Protective ground** – Site wiring must include a protective ground connection to the AC power source or the optional –48-VDC power source.

 **NOTE** *Protective ground* is also known as safety ground or chassis ground.

- **Circuit overloading** – Power circuits and associated circuit breakers must provide enough power and overload protection. To prevent damage to the drive tray, isolate its power source from large switching loads, such as air-conditioning motors, elevator motors, and factory loads.
- **Power interruptions** – The drive tray can withstand these applied voltage interruptions:
 - **Input transient** – 50 percent of the nominal voltage
 - **Duration** – One-half cycle
 - **Maximum frequency** – Once every 10 seconds
- **Power failures** – If a total power failure occurs, the drive tray automatically performs a power-on recovery sequence without operator intervention after the power is restored.

DE1600 Drive Tray Power Input

AC Power Input

The AC power sources must provide the correct voltage, current, and frequency specified on the tray and serial number label.

AC Power Requirements for the DE1600 Drive Tray

| Parameter | Low Range | High Range |
|--------------------------------|-------------|-------------|
| Nominal voltage | 100 VAC | 240 VAC |
| Frequency | 50 to 60 Hz | 50 to 60 Hz |
| Idle current | 2.96 A* | 1.23 A** |
| Maximum operating current | 3.03 A* | 1.26 A** |
| Sequential Drive Group Spin Up | 4.23 A | 1.76 A |
| Simultaneous Drive Spin Up | 4.43 A | 1.83 A |
| System Rating Plate Label | 7.0 A | 2.9 A |

* Typical current: 100 VAC, 60 Hz at 0.87 power supply efficiency and 0.99 power factor. These numbers can vary significantly, depending upon the drives tested in the particular configuration.

**Typical current: 240 VAC, 60 Hz at 0.87 power supply efficiency and 0.99 power factor. These numbers can vary significantly, depending upon the drives tested in the particular configuration.

DC Power Input

Nominal input voltages for the DC power source are as follows:

- Low range: -42VDC
- High range: -60 VDC

The maximum operating current is 21.7 A.

DE1600 Drive Tray Power Factor Correction

Power factor correction is applied within the power supply of each DE1600 drive tray, which maintains the power factor of the drive tray at greater than 0.95 with nominal input voltage.

DE1600 Drive Tray AC Power Cords and Receptacles

Each DE1600 drive tray is shipped with two AC power cords, which use standard AC outlets in the destination country. Each AC power cord connects one of the power supplies in the drive tray to an independent, external AC power source, such as a wall receptacle, or to any uninterruptible power supply (UPS).

DC power is an option that is available for use with your DE1600 drive tray. For more information, see "[DE1600 Drive Tray Optional DC Power Connector Cables and Source Wires.](#)"

DE1600 Drive Tray Optional DC Power Connector Cables and Source Wires

The DE1600 drive tray is shipped with -48-VDC power connector cables if the DC power option is ordered. The -48-VDC power connector cable plugs into the DC power connector on the rear of the drive tray. The three source wires on the other end of the power connector cable connect the drive tray to centralized DC power plant equipment, typically through a bus bar above the cabinet.

⚠ WARNING (W12) Risk of electrical shock – This unit has more than one power source. To remove all power from the unit, all DC MAINS must be disconnected by removing all power connectors (item 4 below) from the power supplies.

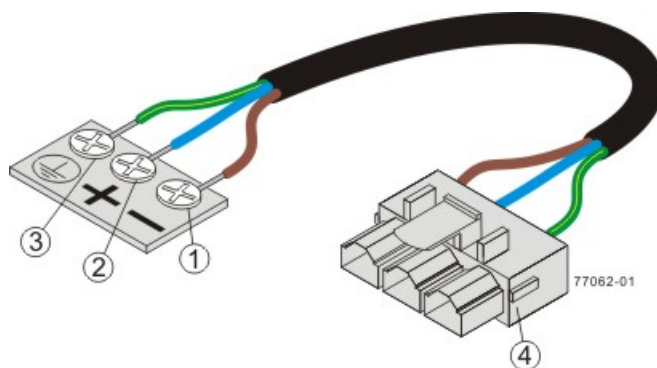

1. Supply (Negative), Brown Wire, -48 VDC
2. Return (Positive), Blue Wire
3. Ground, Green and Yellow Wire
4. DC Power Connector



WARNING (W14) Risk of bodily injury – A qualified service person is required to make the DC power connection according to NEC and CEC guidelines.

Two (or, optionally, four) DC power connector cables are provided with each drive tray. Two DC power connectors are on the two power-fan canisters on the rear of each drive tray if additional redundancy is required.



NOTE It is not mandatory that you connect the second DC power connection on the power-fan canister of the drive tray. The second DC power connection is provided for additional redundancy only and can be connected to a second DC power bus.

Specifications of the DE5600 Drive Tray

The DE5600 drive tray contains Serial Attached SCSI (SAS) drives. Each DE5600 drive tray contains these components:

- A maximum of 24 drives
- One or two power-supply fan canisters
- One or two environmental services monitor (ESM) canisters

DE5600 Drive Tray – Front View

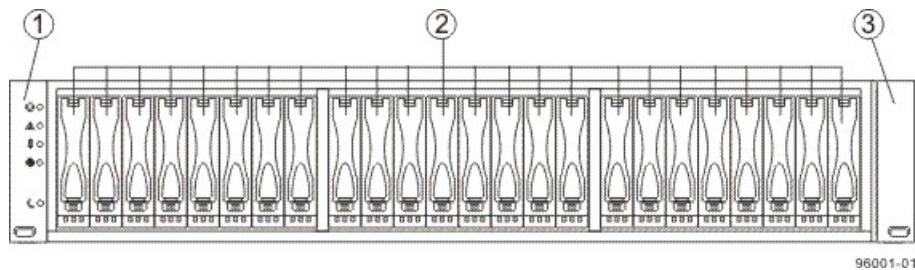

1. Left End Cap (Has the Drive Tray LEDs)
2. Drives
3. Right End Cap

DE5600 Drive Tray – Rear View

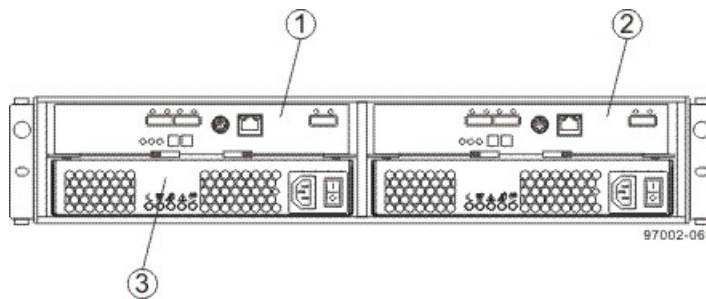

1. ESM A Canister
2. ESM B Canister
3. Power-Fan Canister

Usually, an AC power source supplies power to the power-fan canister. A DC power option is also available.

DE5600 Drive Tray Power Source Options – Rear View

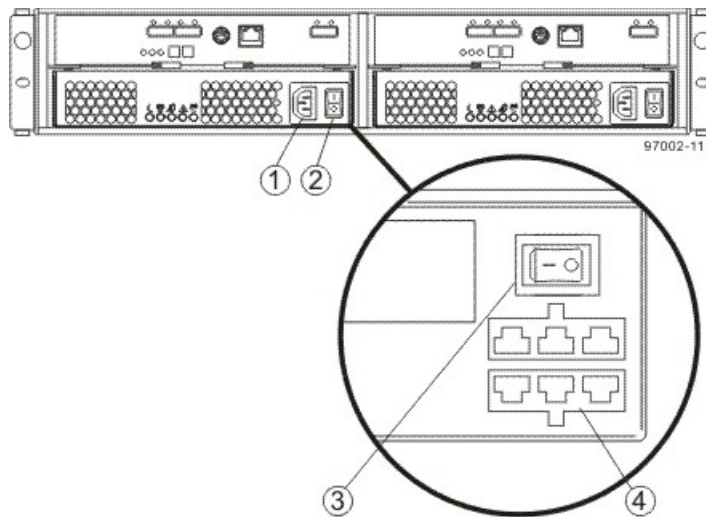

1. AC Power Switch on the AC Power-Fan Canister
2. AC Power Connector
3. DC Power Switch on an Optional DC Power-Fan Canister
4. DC Power Connector

DE5600 Drive Tray Dimensions

Dimensions of the DE5600 Drive Tray – Front View

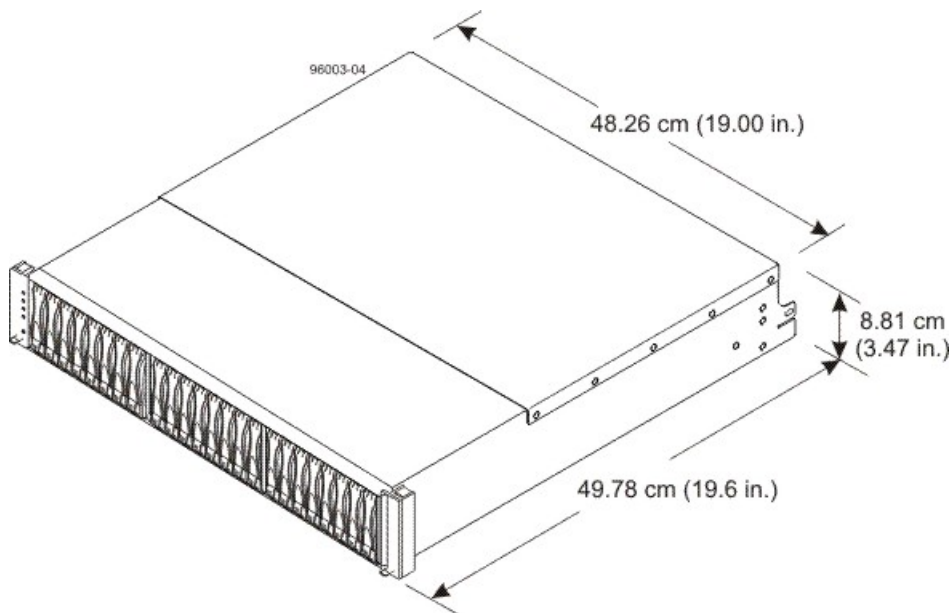

DE5600 Drive Tray Weight

Weights of the DE5600 Drive Tray

| Unit | Weight | | |
|--|------------------|---------------------|--------------------|
| | Maximum* | Empty** | Shipping*** |
| DE5600 drive tray | 26 kg (57.32 lb) | 21.70 kg (47.84 lb) | 31.75 kg (70.0 lb) |
| <p>*Maximum weight indicates a drive tray with all of its drives and other components installed. Because drive weights can vary greatly, this value can vary from the value specified as much as 0.08 kg (0.18 lb) times the maximum number of drives per drive tray for 2.5-in. SAS drives.</p> <p>**Empty weight indicates a drive tray with the ESM canisters, the power-fan canisters, and the drives removed.</p> <p>***Shipping weight indicates the maximum weight of a fully-populated drive tray and all shipping material.</p> | | | |

Component Weights of the DE5600 Drive Tray

| Component | Weight |
|--------------------|--------------------|
| ESM canister | 0.907 kg (2.00 lb) |
| Power-fan canister | 2.500 kg (5.51 lb) |
| 2.5-in. SAS drive | 0.3 kg (0.6 lb) |

DE5600 Drive Tray Shipping Dimensions

Drive Tray and Shipping Carton Dimensions for the DE5600 Drive Tray

| Height | Width | Depth |
|--------------------|----------------------|-------------------|
| 24.13 cm (9.5 in.) | 58.42 cm (23.00 in.) | 63.50 cm (25 in.) |

DE5600 Drive Tray Temperature and Humidity

Temperature Requirements and Humidity Requirements for the DE5600 Drive Tray

| Condition | Parameter | Requirement |
|-------------|--|-------------------------------|
| Temperature | Operating range (both cabinet and subsystem) | 10°C to 35° C 50°F to 104°F) |
| | Maximum rate of change | 10°C (18°F) per hour] |
| | Storage range | -10°C to 50°C (14°F to 122°F) |
| | Maximum rate of change | 15°C (59°F) per hour |

| Condition | Parameter | Requirement |
|--|--|--------------------------------|
| | Transit range | -40°C to 60°C (-40°F to 140°F) |
| | Maximum rate of change | 20°C (68°F) per hour |
| Relative humidity (no condensation) | Operating range (both cabinet and subsystem) | 20% to 80% |
| | Storage range | 10% to 90% |
| | Transit range | 5% to 90% |
| | Operating gradient | 10°C (50°F) per hour |
| | Storage gradient | 15°C (59°F) per hour |
| | Transit gradient | 20°C (68°F) per hour |
| | Maximum dew point | 26°C (79°F) |
| | Maximum gradient | 10% per hour |
| *If you plan to operate a system at an altitude between 1000 m to 3000 m (3280 ft to 9842 ft) above sea level, lower the environmental temperature 1.7°C (3.3°F) for every 1000 m (3280 ft) above sea level. | | |

DE5600 Drive Tray Altitude Ranges

Altitude Ranges for the DE5600 Drive Tray

| Environment | Altitude |
|-------------|---|
| Operating | 30.5 m (100 ft) below sea level to 3000 m (9840 ft) above sea level |
| Storage | 30.5 m (100 ft) below sea level to 3000 m (9840 ft) above sea level |
| Transit | 30.5 m (100 ft) below sea level to 12,000 m (40,000 ft) above sea level |

DE5600 Drive Tray Airflow and Heat Dissipation

Airflow goes from the front of the drive tray to the rear of the drive tray. Allow at least 76 cm (30 in.) of clearance in front of the drive tray and at least 61 cm (24 in.) of clearance behind the drive tray for service clearance, ventilation, and heat dissipation.

Airflow Through the DE5600 Drive Tray – Front View

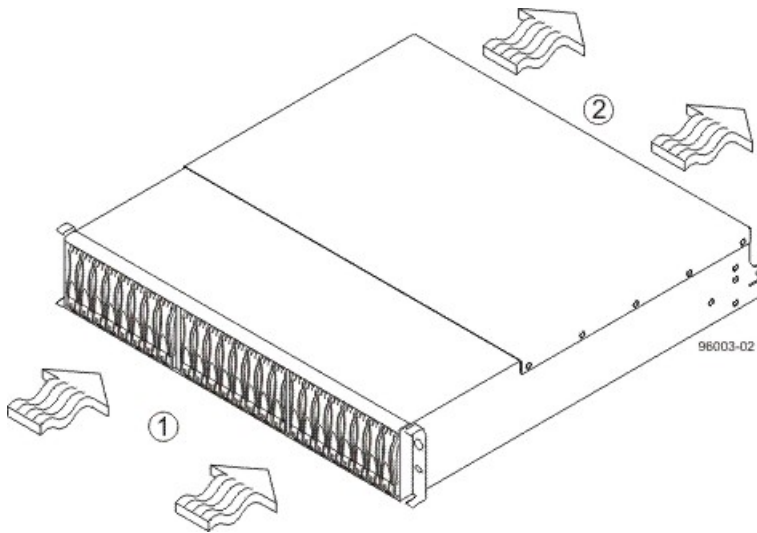

1. 76 cm (30 in.) clearance in front of the cabinet
2. 61 cm (24 in.) clearance behind the cabinet

The tabulated power and heat dissipation values in the following table are the maximum measured operating power.

Power Ratings and Heat Dissipation for the DE5600 Drive Tray

| Unit | KVA | Watts (AC) | Btu/Hr |
|-------------------|-------|------------|--------|
| DE5600 drive tray | 0.241 | 240.1 | 821 |

DE5600 Drive Tray Acoustic Noise

Acoustic Noise at 25°C for the DE5600 Drive Tray

| Measurement | Level |
|---------------------------------|------------------|
| Sound power (standby operation) | 6.5 bels maximum |
| Sound power (normal operation) | 6.8 bels maximum |

DE5600 Drive Tray Site Wiring and Power

The DE5600 drive tray uses wide-ranging, redundant power supplies that automatically accommodate voltages to the AC power source or the optional –48-VDC power source. The power supplies meet standard voltage requirements for both North American (USA and Canada) operation and worldwide (except USA and Canada) operation. The power supplies use standard industrial wiring with line-to-neutral or line-to-line power connections.

 **NOTE** Power for the optional –48-VDC power configuration is supplied by a centralized DC power plant instead of the AC power source in the cabinet. Refer to the associated manufacturer’s documentation for specific DC power source requirements.

Keep this information in mind when preparing the installation site for the drive tray:

- **Protective ground** – Site wiring must include a protective ground connection to the AC power source or the optional –48-VDC power source.

 **NOTE** *Protective ground* is also known as safety ground or chassis ground.

- **Circuit overloading** – Power circuits and associated circuit breakers must provide enough power and overload protection. To prevent damage to the drive tray, isolate its power source from large switching loads, such as air-conditioning motors, elevator motors, and factory loads.
- **Power interruptions** – The drive tray can withstand these applied voltage interruptions:
 - **Input transient** – 50 percent of the nominal voltage
 - **Duration** – One-half cycle
 - **Maximum frequency** – Once every 10 seconds
- **Power failures** – If a total power failure occurs, the drive tray automatically performs a power-on recovery sequence without operator intervention after the power is restored.

DE5600 Drive Tray AC Power Input

AC Power Input

The AC power sources must provide the correct voltage, current, and frequency specified on the tray and serial number label.

AC Power Requirements for the DE5600 Drive Tray

| Parameter | Low Range | High Range |
|--------------------------------|-------------|-------------|
| Nominal voltage | 100 VAC | 240 VAC |
| Frequency | 50 to 60 Hz | 50 to 60 Hz |
| Idle current | 2.96 A* | 1.23 A** |
| Maximum operating current | 3.03 A* | 1.26 A** |
| Sequential Drive Group Spin Up | 4.23 A | 1.76 A |
| Simultaneous Drive Spin Up | 4.43 A | 1.83 A |
| System Rating Plate Label | 7.0 A | 2.9 A |

* Typical current: 100 VAC, 60 Hz at 0.87 power supply efficiency and 0.99 power factor. These numbers can vary significantly, depending upon the drives tested in the particular configuration.

**Typical current: 240 VAC, 60 Hz at 0.87 power supply efficiency and 0.99 power factor. These numbers can vary significantly, depending upon the drives tested in the particular configuration.

DC Power Input

Nominal input voltages for the DC power source are as follows:

- Low range: –42 VDC
- High range: –60 VDC

The maximum operating current is 21.7 A.

DE5600 Drive Tray Power Factor Correction

Power factor correction is applied within the power supply of each DE5600 drive tray, which maintains the power factor of the drive tray at greater than 0.95 with nominal input voltage.

DE5600 Drive Tray AC Power Cords and Receptacles

Each DE5600 drive tray is shipped with two AC power cords, which use the standard AC outlets in the destination country. Each AC power cord connects one of the power supplies in the drive tray to an independent, external AC power source, such as a wall receptacle, or to any uninterruptible power supply (UPS).

DC power is an option that is available for use with your DE5600 drive tray. For more information, see "[DE5600 Drive Tray Optional DC Power Connector Cables and Source Wires.](#)"

DE5600 Drive Tray Optional DC Power Connector Cables and Source Wires

The DE5600 drive tray is shipped with –48-VDC power connector cables if the DC power option is ordered. The –48-VDC power connector cable plugs into the DC power connector on the rear of the drive tray. The three source wires on the other end of the power connector cable connect the drive tray to centralized DC power plant equipment, typically through a bus bar above the cabinet.

⚠ WARNING (W12) Risk of electrical shock – This unit has more than one power source. To remove all power from the unit, all DC MAINS must be disconnected by removing all power connectors (item 4 below) from the power supplies.

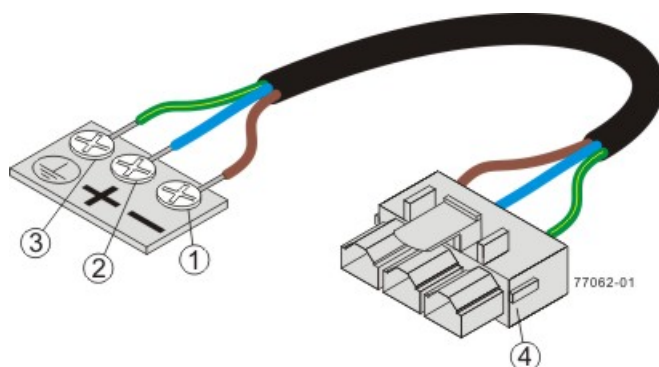

1. Supply (Negative), Brown Wire, –48 VDC
2. Return (Positive), Blue Wire
3. Ground, Green and Yellow Wire
4. DC Power Connector



WARNING (W14) Risk of bodily injury – A qualified service person is required to make the DC power connection according to NEC and CEC guidelines.

Two (or, optionally, four) DC power connector cables are provided with each drive tray. Two DC power connectors are on the two power-fan canisters on the rear of each drive tray if additional redundancy is required.



NOTE It is not mandatory that you connect the second DC power connection on the power-fan canister of the drive tray. The second DC power connection is provided for additional redundancy only and can be connected to a second DC power bus.

Specifications of the DE6600 Drive Tray

The DE6600 drive tray is a high-density SAS 2.0 (6Gb/s) drive enclosure with 60 near-line 3.5" SAS drives, housed in five drawers with 12 drives each.

The DE6600 drive tray contains these components:

- Up to 60 SAS drives
- Two power canisters
- Two fan canisters
- Two environmental services monitor (ESM) canisters

DE6600 Drive Tray – Front View with Bezel Removed

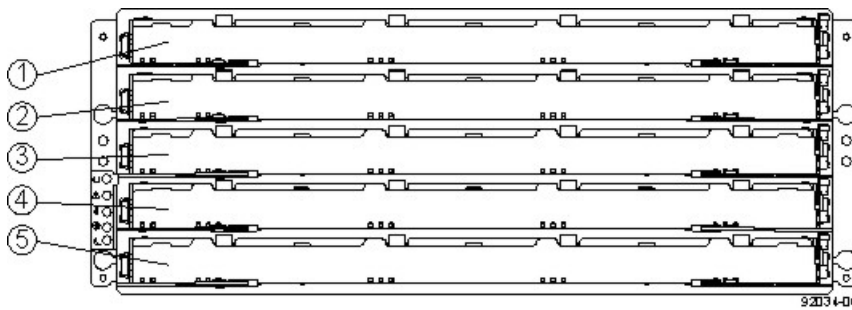

1. Drive Drawer 1
2. Drive Drawer 2
3. Drive Drawer 3
4. Drive Drawer 4
5. Drive Drawer 5

DE6600 Drive Tray – Rear View

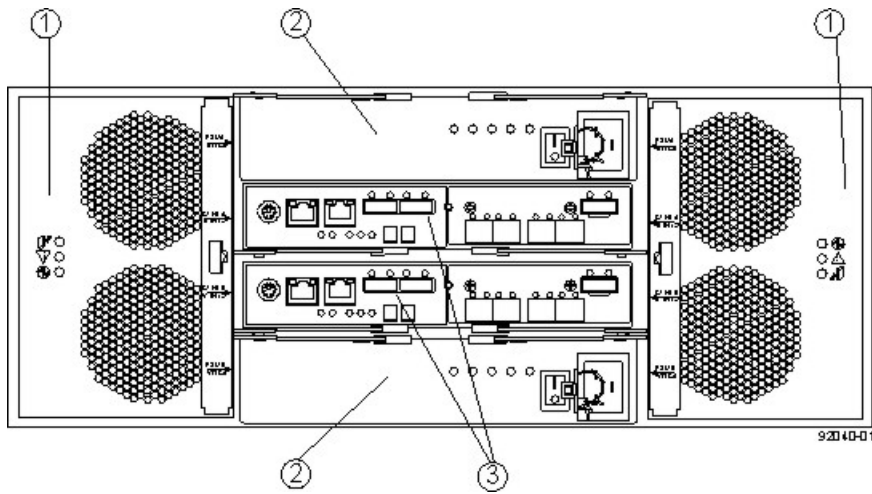

1. Fan Canisters
2. Power Canisters
3. ESM Canisters

An AC power source supplies power to the power canister.

Power Source Options for the DE6600 Drive Tray – Rear View

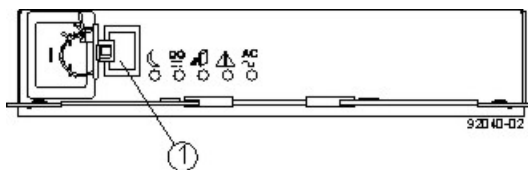

1. AC Power Switch on the Power Canister

The drive trays come with drive interface ports that enable you to establish up to four drive channels when using the CE7900 controller tray for your disk storage solution.

DE6600 Drive Tray Dimensions

The DE6600 drive tray is only available as a rackmount model that conforms to the 100-cm (40.0-in.) rack depth.

Dimensions of the DE6600 Drive Tray – Front View

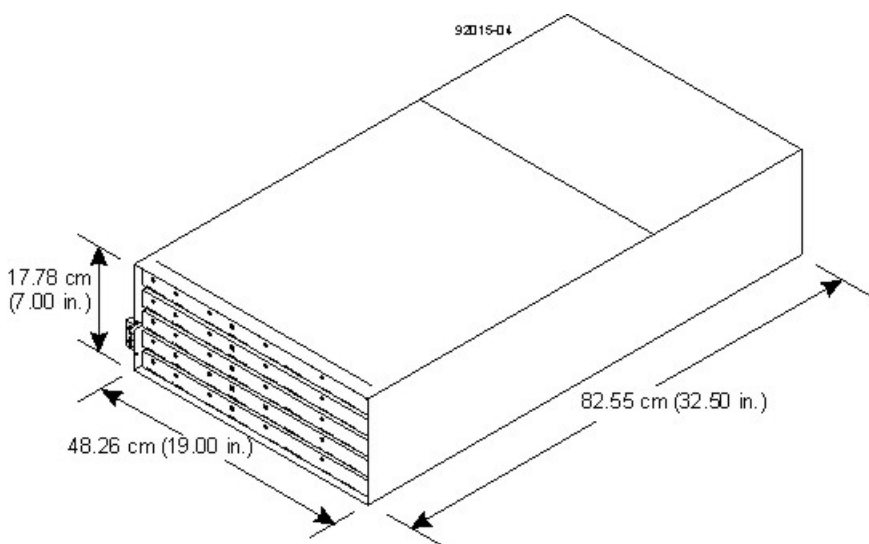

DE6600 Drive Tray Weight

Weights of the DE6600 Drive Tray

| Unit | Weight | | |
|-------------------|-------------------|------------------|-------------------|
| | Maximum* | Empty** | Shipping*** |
| DE6600 drive tray | 105.2 kg (232 lb) | 59.8 kg (132 lb) | 193.2 kg (426 lb) |

*Maximum weight indicates a drive tray with all of its drives and other components installed. Because drive weights can vary greatly, this value can vary from the value specified as much as 0.3 kg (0.6 lb) times the maximum number of drives per drive tray for drives weighing 0.725 kg (1.6 lb).

**Empty weight indicates a drive tray with the ESM canisters, the power canisters, the fan canisters, and the drives removed.

***Shipping weight indicates the empty weight of a drive tray and all shipping material, as well as the weight of the 60 drives that are shipped separately in multipack cartons.

Component Weights of the DE6600 Drive Tray

| Component | Weight |
|----------------|------------------------------|
| ESM canister | 1.65 kg (3.64 lb) |
| Power canister | 2.5 kg (5.5 lb) |
| Fan canister | Approximately 1 kg (2.16 lb) |
| Drive | 0.74 kg (1.64 lb) |

DE6600 Drive Tray Shipping Dimensions

Shipping Carton Dimensions for the DE6600 Drive Tray

| Height | Width | Depth |
|-------------------|----------------------|-----------------------|
| 48.26 cm (19 in.) | 60.96 cm (24.00 in.) | 100.97 cm (39.75 in.) |

DE6600 Drive Tray Temperature and Humidity

Temperature Requirements and Humidity Requirements for the DE6600 Drive Tray

| Condition | Parameter | Requirement |
|--|------------------------|---|
| Temperature* | Operating range | 0°C to 35°C (32°F to 95°F) |
| | Maximum rate of change | 10°C (95°F) per hour |
| | Storage range | -10°C to 50°C (95°F to 122°F) |
| | Maximum rate of change | 15°C (59°F) per hour |
| | Transit range | -40°C to 60°C (-40°F to 140° F) without the battery |
| | Maximum rate of change | 20°C (68°F) per hour |
| Relative humidity (no condensation) | Operating range | 20% to 80% |
| | Storage range | 10% to 90% |
| | Transit range | 5% to 95% |
| | Maximum dew point | 26°C (79°F) |
| | Maximum gradient | 10% per hour |
| *If you plan to operate a system at an altitude between 1000 m to 3000 m (3280 ft to 9842 ft) above sea level, lower the environmental temperature 1.7°C (3.3°F) for every 1000 m (3280 ft) above sea level. | | |

DE6600 Drive Tray Altitude Ranges

Altitude Ranges for the DE6600 Drive Tray

| Environment | Altitude |
|-------------|---|
| Operating | 30.5 m (100 ft) below sea level to 3000 m (9842 ft) above sea level |
| Storage | 30.5 m (100 ft) below sea level to 3000 m (9842 ft) above sea level |

| Environment | Altitude |
|-------------|---|
| Transit | 30.5 m (100 ft) below sea level to 12,000 m (40,000 ft) above sea level |

DE6600 Drive Tray Airflow and Heat Dissipation

Airflow goes from the front of the drive tray to the rear of the drive tray. Allow at least 81 cm (32 in.) of clearance in front of the drive tray and at least 61 cm (24 in.) of clearance behind the drive tray for service clearance, ventilation, and heat dissipation.

Airflow Through the DE6600 Drive Tray – Front View

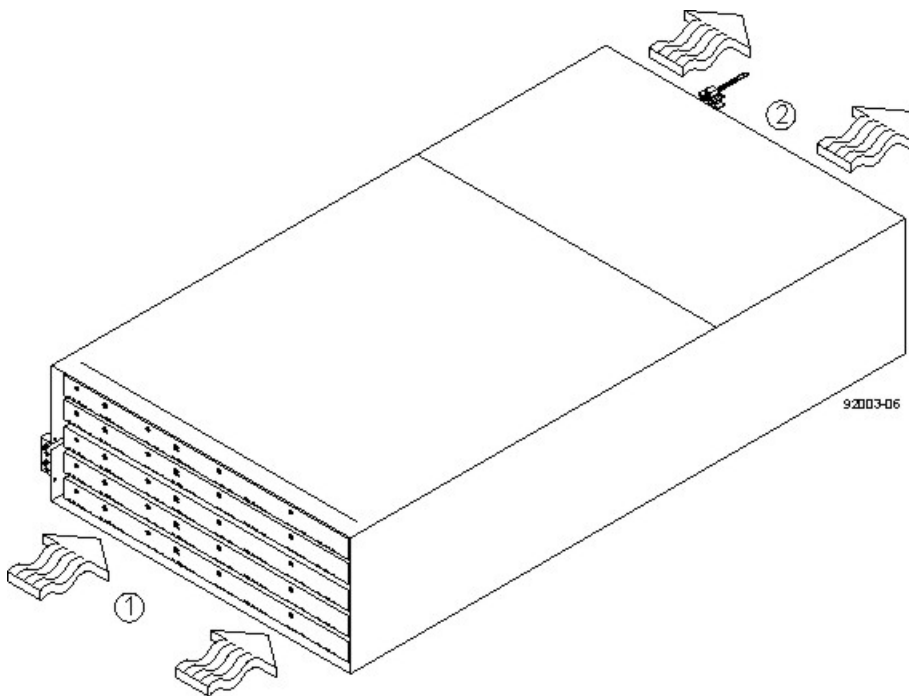

1. 81 cm (32 in.) clearance in front of the cabinet
2. 61 cm (24 in.) clearance behind the cabinet

The tabulated power and heat dissipation values in the following table represent the maximum measured operating power.

Power Ratings and Heat Dissipation for the DE6600 Drive Tray

| Unit | KVA | Watts (AC) | Btu/hr |
|--|-------|------------|--------|
| DE6600 drive tray with two power supplies, two ESMs, 60 drives (Seagate 2000-Gb SAS drives and controllers), and two fan canisters, full speed | 1.268 | 1222 | 4180 |

DE6600 Drive Tray Acoustic Noise

Sound Levels for the DE6600 Drive Tray

| Measurement | Level |
|---------------------------------|----------|
| Sound power (standby operation) | 6.5 bels |
| Sound power (normal operation) | 6.8 bels |
| Sound pressure | 68 dBA |

DE6600 Drive Tray Site Wiring and Power

The agency ratings for the DE6600 drive tray are 7.56 A at 200 VAC and 6.3 A at 240 VAC. These ratings are the overall maximum AC currents for this system.

The DE6600 drive tray uses wide-ranging, redundant power supplies that automatically accommodate voltages to the AC power source. The power supplies meet standard voltage requirements for both North American (USA and Canada) operation and worldwide (except USA and Canada) operation. The power supplies use standard industrial wiring with line-to-neutral power connections or line-to-line power connections.

Keep this information in mind when you prepare the installation site for the drive tray:

- **Protective ground** – Site wiring must include a protective ground connection to the AC power source.



NOTE *Protective ground* is also known as safety ground or chassis ground.

- **Circuit overloading** – Power circuits and associated circuit breakers must provide enough power and overload protection. To prevent damage to the drive tray, isolate its power source from large switching loads, such as air-conditioning motors, elevator motors, and factory loads.
- **Power interruptions** – The drive tray can withstand these applied voltage interruptions:
 - **Input transient** – 50 percent of the nominal voltage
 - **Duration** – One-half cycle
 - **Maximum frequency** – Once every 10 seconds
- **Power failures** – If a total power failure occurs, the drive tray automatically performs a power-on recovery sequence without operator intervention after the power is restored.

DE6600 Drive Tray Power Input

Each power supply contains one 15-A slow-blow fuse.

AC Power Requirements for the DE6600 Drive Tray

| Parameter | High Range |
|-----------------|----------------|
| Nominal voltage | 200 to 240 VAC |
| Frequency | 50 to 60 Hz |

| Parameter | High Range |
|---------------------------|------------|
| Idle current | 6.0 A |
| Maximum operating current | 7.56 A |
| Maximum surge current | 8.0 A |

DE6600 Drive Tray Power Factor Correction

Power factor correction is applied within the power canister of each DE6600 drive tray, which maintains the power factor of the drive tray at no less than 0.95 with at all input voltage levels.

DE6600 Drive Tray AC Power Cords and Receptacles

Each DE6600 drive tray is shipped with two AC power cords, which fit the standard AC outlets in the destination country. Each AC power cord connects one of the power canisters in the drive tray to an independent, external AC power source, such as a wall receptacle, or to any uninterruptible power supply (UPS).



ATTENTION Possible risk of equipment failure – To ensure proper cooling, the DE6600 drive tray always uses two power supplies.

Specifications of the DE6900 Drive Tray

The DE6900 drive tray has five separate drawers and is capable of handling 4-Gb Fibre Channel speeds. Each drive drawer contains up to 12 drives, making 60 drives the total capacity of the DE6900 drive tray.

The DE6900 drive tray contains these components:

- Up to 60 SATA drives
- Two power canisters
- Two fan canisters
- Two environmental services monitor (ESM) canisters

DE6900 Drive Tray – Front View with Bezel Removed

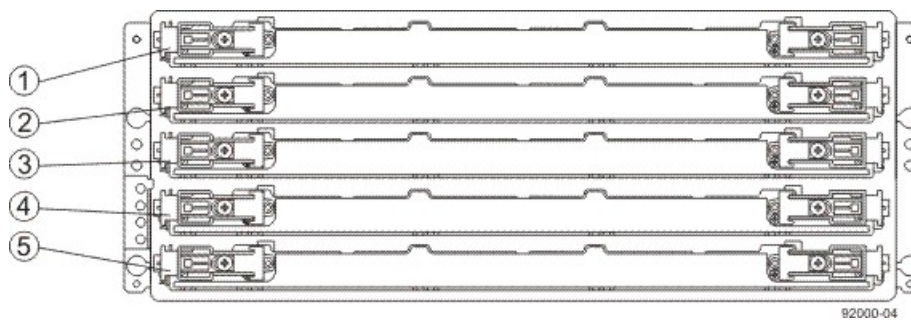

1. Drive Drawer 1
2. Drive Drawer 2
3. Drive Drawer 3
4. Drive Drawer 4
5. Drive Drawer 5

DE6900 Drive Tray – Rear View

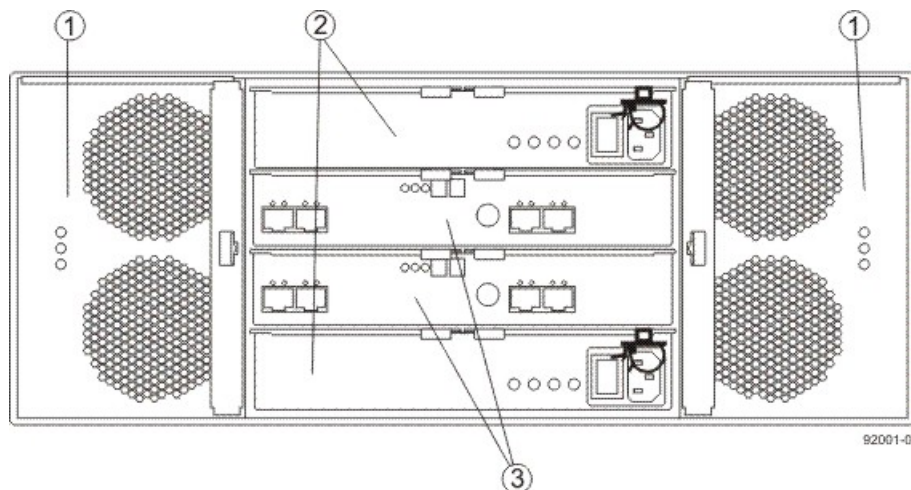

1. Fan Canisters
2. Power Canisters
3. ESM Canisters

An AC power source supplies power to the power canister.

Power Source Options for the DE6900 Drive Tray – Rear View

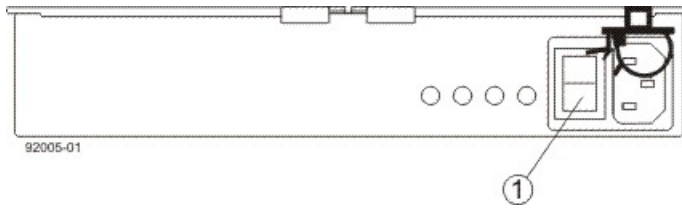

1. AC Power Switch on the Power Canister

The drive trays come with drive interface ports that enable you to establish up to four drive channels when using the CE7900 controller tray for your disk storage solution.

DE6900 Drive Tray Dimensions

The DE6900 drive tray is only available as a rackmount model that conforms to the 100-cm (40.0-in.) rack depth.

Dimensions of the DE6900 Drive Tray – Front View

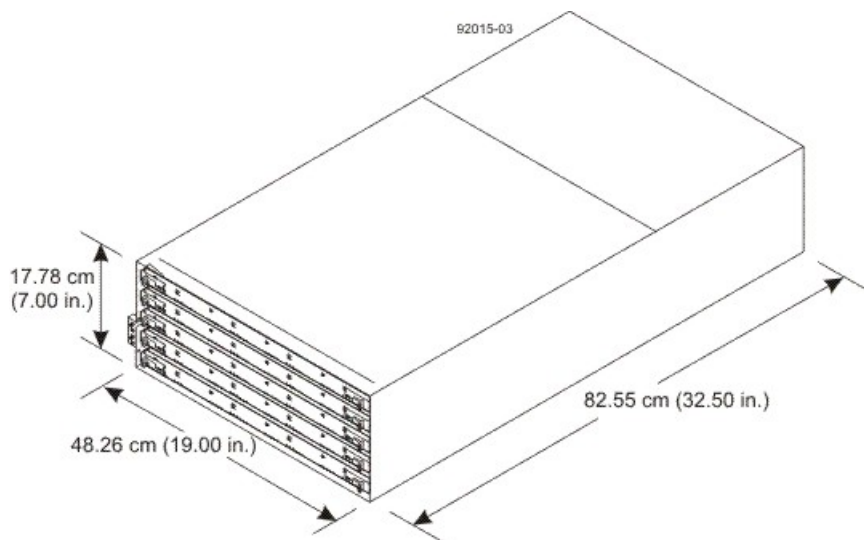

DE6900 Drive Tray Weight

Weights of the DE6900 Drive Tray

| Unit | Weight | | |
|-------------------|-------------------|------------------|-----------------|
| | Maximum* | Empty** | Shipping*** |
| DE6900 drive tray | 102.1 kg (225 lb) | 56.7 kg (125 lb) | 192 kg (420 lb) |

*Maximum weight indicates a drive tray with all of its drives and other components installed. Because drive weights can vary greatly, this value can vary from the value specified as much as 0.3 kg (0.6 lb) times the maximum number of drives per drive tray for drives weighing 0.725 kg (1.6 lb).

**Empty weight indicates a drive tray with the ESM canisters, the power canisters, the fan canisters, and the drives removed.

| Unit | Weight | | |
|--|----------|---------|-------------|
| | Maximum* | Empty** | Shipping*** |
| ***Shipping weight indicates the empty weight of a drive tray and all shipping material, as well as the weight of the 60 drives that are shipped separately in multi-pack cartons. | | | |

Component Weights of the DE6900 Drive Tray

| Component | Weight |
|----------------|-----------------------------|
| ESM canister | 1.65 kg (3.64 lb) |
| Power canister | 2.5 kg (5.46 lb) |
| Fan canister | Approximately 1 kg (2.2 lb) |
| Drive | 0.74 kg (1.64 lb) |

DE6900 Drive Tray Shipping Dimensions

Shipping Carton Dimensions for the DE6900 Drive Tray

| Height | Width | Depth |
|-------------------|----------------------|-----------------------|
| 48.26 cm (19 in.) | 60.96 cm (24.00 in.) | 100.97 cm (39.75 in.) |

DE6900 Drive Tray Temperature and Humidity

Temperature Requirements and Humidity Requirements for the DE6900 Drive Tray

| Condition | Parameter | Requirement |
|-------------------------------------|------------------------|---|
| Temperature* | Operating range | 0°C to 35°C (32°F to 95°F) |
| | Maximum rate of change | 10°C (95°F) per hour |
| | Storage range | -10°C to 50°C (95°F to 122°F) |
| | Maximum rate of change | 15°C (59°F) per hour |
| | Transit range | -40°C to 60°C (-40°F to 140° F) without the battery |
| | Maximum rate of change | 20°C (68°F) per hour |
| Relative humidity (no condensation) | Operating range | 20% to 80% |
| | Storage range | 10% to 90% |
| | Transit range | 5% to 95% |

| Condition | Parameter | Requirement |
|--|-------------------|--------------|
| | Maximum dew point | 26°C (79°F) |
| | Maximum gradient | 10% per hour |
| *If you plan to operate a system at an altitude between 1000 m to 3000 m (3280 ft to 9842 ft) above sea level, lower the environmental temperature 1.7°C (3.3°F) for every 1000 m (3280 ft) above sea level. | | |

DE6900 Drive Tray Altitude Ranges

Altitude Ranges for the DE6900 Drive Tray

| Environment | Altitude |
|-------------|---|
| Operating | 30.5 m (100 ft) below sea level to 3000 m (9842 ft) above sea level |
| Storage | 30.5 m (100 ft) below sea level to 3000 m (9842 ft) above sea level |
| Transit | 30.5 m (100 ft) below sea level to 12,000 m (40,000 ft) above sea level |

DE6900 Drive Tray Airflow and Heat Dissipation

Airflow goes from the front of the drive tray to the rear of the drive tray. Allow at least 81 cm (32 in.) of clearance in front of the drive tray and at least 61 cm (24 in.) of clearance behind the drive tray for service clearance, ventilation, and heat dissipation.

Airflow Through the DE6900 Drive Tray – Front View

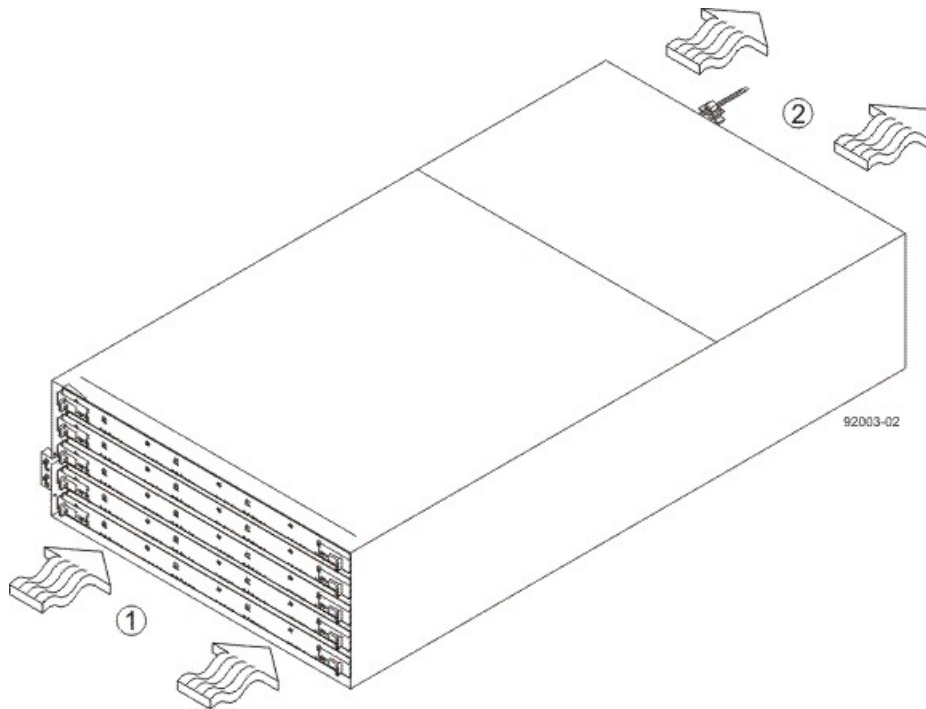

1. 81 cm (32 in.) clearance in front of the cabinet
2. 61 cm (24 in.) clearance behind the cabinet

The tabulated power and heat dissipation values in the following table are the maximum measured operating power.

Power Ratings and Heat Dissipation for the DE6900 Drive Tray

| Unit | KVA | Watts (AC) | Btu/hr |
|--|-------|------------|--------|
| DE6900 drive tray with two power supplies, two ESMs, 60 drives (Seagate 1000-Gb SATA), and two fan canisters, full speed | 1.203 | 1181 | 4039 |

DE6900 Drive Tray Acoustic Noise

Sound Levels for the DE6900 Drive Tray

| Measurement | Level |
|---------------------------------|----------|
| Sound power (standby operation) | 6.5 bels |
| Sound power (normal operation) | 6.8 bels |
| Sound pressure | 68 dBA |

DE6900 Drive Tray Site Wiring and Power

The agency ratings for the DE6900 drive tray are 8.64 A at 200 VAC and 7.20 A at 240 VAC. These ratings are the overall maximum AC currents for this system.

The DE6900 drive tray uses wide-ranging, redundant power supplies that automatically accommodate voltages to the AC power source. The power supplies meet standard voltage requirements for both North American (USA and Canada) operation and worldwide (except USA and Canada) operation. The power supplies use standard industrial wiring with line-to-neutral or line-to-line power connections.

Keep this information in mind when you prepare the installation site for the drive tray:

- **Protective ground** – Site wiring must include a protective ground connection to the AC power source.



NOTE *Protective ground* is also known as safety ground or chassis ground.

- **Circuit overloading** – Power circuits and associated circuit breakers must provide enough power and overload protection. To prevent damage to the drive tray, isolate its power source from large switching loads, such as air-conditioning motors, elevator motors, and factory loads.
- **Power interruptions** – The drive tray can withstand these applied voltage interruptions:
 - **Input transient** – 50 percent of the nominal voltage
 - **Duration** – One-half cycle
 - **Maximum frequency** – Once every 10 seconds
- **Power failures** – If a total power failure occurs, the drive tray automatically performs a power-on recovery sequence without operator intervention after the power is restored.

DE6900 Drive Tray Power Input

Each power supply contains one 15-A slow-blow fuse.

AC Power Requirements for the DE6900 Drive Tray

| Parameter | High Range |
|---------------------------|----------------|
| Nominal voltage | 200 to 240 VAC |
| Frequency | 50 to 60 Hz |
| Idle current | 5.5 A |
| Maximum operating current | 9.4 A |
| Maximum surge current | 10.34 A |

DE6900 Drive Tray Power Factor Correction

Power factor correction is applied within the power canister of each DE6900 drive tray, which maintains the power factor of the drive tray at no less than 0.95 with at all input voltage levels.

DE6900 Drive Tray AC Power Cords and Receptacles

Each DE6900 drive tray is shipped with two AC power cords, which fit the standard AC outlets in the destination country. Each AC power cord connects one of the power canisters in the drive tray to an independent, external AC power source, such as a wall receptacle, or to any uninterruptible power supply (UPS).



ATTENTION Possible risk of equipment failure – To ensure proper cooling, the DE6900 drive tray always uses two power supplies.

Specifications of the FC4600 Drive Tray

The FC4600 drive tray is a 16-slot drive tray capable of handling 4-Gb Fibre Channel speeds. The drive tray is designed to be used by disk storage customers who desire top-of-the-line storage arrays. It comes in a deskmount model and a rackmount model.

The FC4600 drive tray contains these components:

- Up to 16 Fibre Channel drives
- Two power-fan canisters
- Two environmental services monitor (ESM) canisters

FC4600 Drive Tray – Front View and Rear View

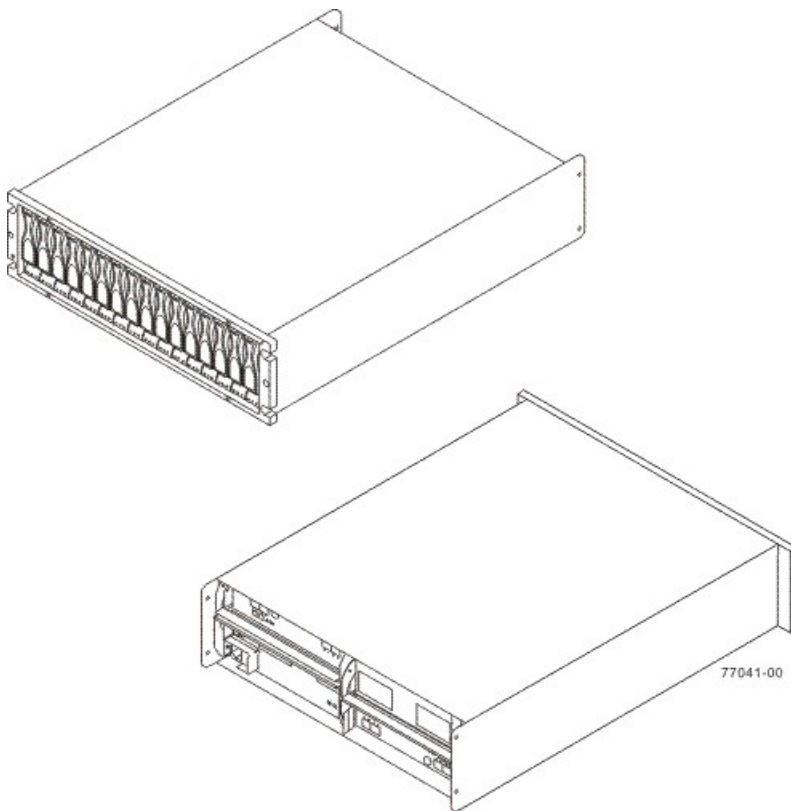

Usually, an AC power source supplies power to the power-fan canister. A DC power option is also available.

Power Source Options for the FC4600 Drive Tray – Rear View

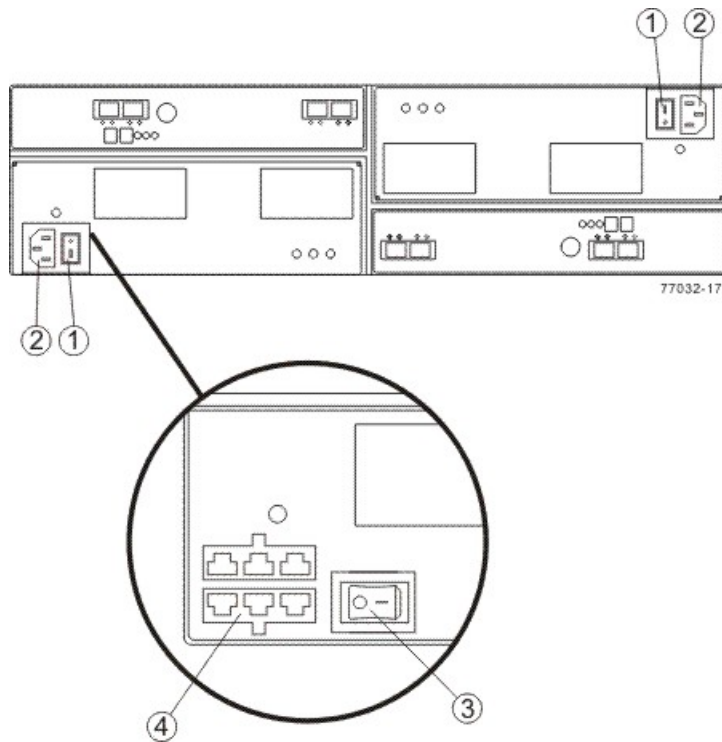

1. AC Power Switch on the AC Power-Fan Canister
2. AC Power Connector
3. DC Power Switch on an Optional Power-Fan Canister
4. Two DC Power Connectors

The drive trays come with drive interface ports that enable you to establish up to eight drive channels when using the CE7900 controller tray for your disk storage solution.

FC4600 Drive Tray Dimensions

The FC4600 drive tray conforms to the 48.3-cm (19.0-in.) rack standard.

Dimensions of the FC4600 Drive Tray (Deskside Model and Rackmount Model) – Front View

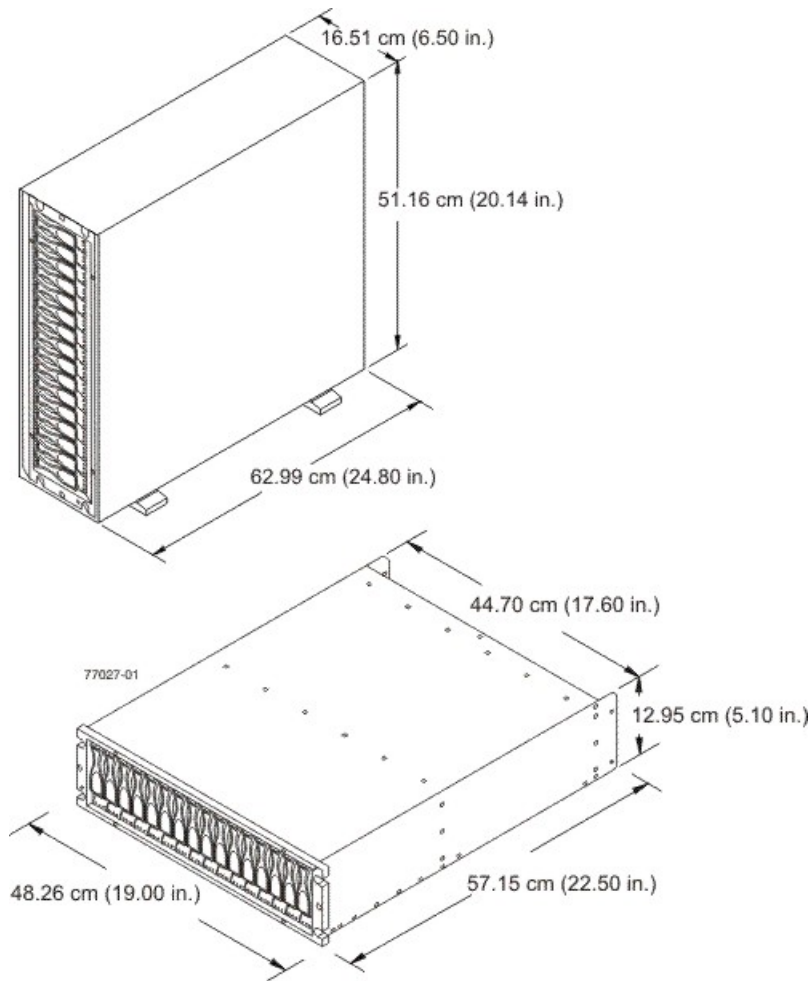

FC4600 Drive Tray Weight

Weights of the FC4600 Drive Tray

| Unit | Weight | | |
|------------------------------------|---------------------|--------------------|---------------------|
| | Maximum* | Empty** | Shipping*** |
| FC4600 drive tray, deskside model | 54.88 kg (121.0 lb) | 28.58 kg (63.0 lb) | 66.68 kg (147.0 lb) |
| FC4600 drive tray, rackmount model | 42.18 kg (93.0 lb) | 15.88 kg (35.0 lb) | 53.98 kg (119.0 lb) |

*Maximum weight indicates a drive tray with all of its drives and other components installed. Because drive weights can vary greatly, this value can vary from the value specified as much as 0.3 kg (0.6 lb) times the maximum number of drives per drive tray for drives weighing 1.0 kg (2.2 lb).

**Empty weight indicates a drive tray with the ESM canisters, the power-fan canisters, and the drives removed.

| Unit | Weight | | |
|--|----------|---------|-------------|
| | Maximum* | Empty** | Shipping*** |
| ***Shipping weight indicates the maximum weight of a drive tray and all shipping material. | | | |

Component Weights of the FC4600 Drive Tray

| Component | Weight |
|--------------------|-------------------------------|
| ESM canister | 2.313 kg (5.10 lb) |
| Power-fan canister | 2.449 kg (5.40 lb) |
| Drive | Approximately 1.0 kg (2.2 lb) |

FC4600 Drive Tray Shipping Dimensions

Shipping Carton Dimensions for the FC4600 Drive Tray

| Height | Width | Depth |
|---|----------------------|----------------------|
| 45.72 cm (18.00 in.) – Includes the height of the pallet. | 62.23 cm (24.50 in.) | 80.65 cm (31.75 in.) |

FC4600 Drive Tray Temperature and Humidity

Temperature Requirements and Humidity Requirements for the FC4600 Drive Tray

| Condition | Parameter | Requirement |
|-------------------------------------|------------------------|---------------------------------|
| Temperature* | Operating range | 10°C to 40°C (50°F to 104°F) |
| | Maximum rate of change | 10°C (18°F) per hour |
| | Storage range | -10°C to 50°C (14°F to 122°F) |
| | Maximum rate of change | 15°C (27°F) per hour |
| | Transit range | -40°C to 60°C (-40°F to 140° F) |
| | Maximum rate of change | 20°C (36°F) per hour |
| Relative humidity (no condensation) | Operating range | 20% to 80% |
| | Storage range | 10% to 90% |
| | Transit range | 5% to 95% |
| | Maximum dew point | 26°C (79°F) |

| Condition | Parameter | Requirement |
|--|------------------|--------------|
| | Maximum gradient | 10% per hour |
| *If you plan to operate a system at an altitude between 1000 m to 3000 m (3280 ft to 9842 ft) above sea level, lower the environmental temperature 1.7°C (3.3°F) for every 1000 m (3280 ft) above sea level. | | |

FC4600 Drive Tray Altitude Ranges

Altitude Ranges for the FC4600 Drive Tray

| Environment | Altitude |
|-------------|---|
| Operating | 30.5 m (100 ft) below sea level to 3000 m (9842 ft) above sea level |
| Storage | 30.5 m (100 ft) below sea level to 3000 m (9842 ft) above sea level |
| Transit | 30.5 m (100 ft) below sea level to 12,000 m (40,000 ft) above sea level |

FC4600 Drive Tray Airflow and Heat Dissipation

Airflow goes from the front of the drive tray to the rear of the drive tray. Allow at least 76 cm (30 in.) of clearance in front of the drive tray and at least 61 cm (24 in.) of clearance behind the drive tray for service clearance, ventilation, and heat dissipation.

Airflow Through the FC4600 Drive Tray – Front View

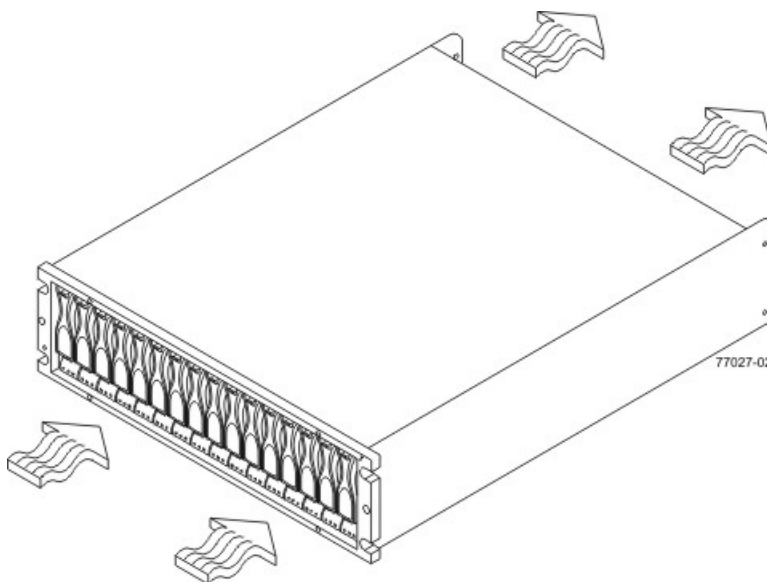

The tabulated power and heat dissipation values in the following table are the maximum measured operating power.

Power Ratings and Heat Dissipation for the FC4600 Drive Tray

| Unit | KVA | Watts (AC) | Btu/hr | Amps (240 VAC) |
|-------------------|-------|------------|--------|----------------|
| FC4600 drive tray | 0.462 | 444 | 1517 | 1.85 |

FC4600 Drive Tray Acoustic Noise

Sound Levels for the FC4600 Drive Tray

| Measurement | Level |
|----------------|----------|
| Sound power | 6.5 bels |
| Sound pressure | 65 dBA |

FC4600 Drive Tray Site Wiring and Power

The agency ratings for the FC4600 drive tray are 4.44 A at 100 VAC and 1.85 A at 240 VAC. These ratings are the overall maximum AC currents for this system.

The FC4600 drive tray uses wide-ranging, redundant power supplies that automatically accommodate voltages to the AC power source or the optional –48-VDC power source. The power supplies meet standard voltage requirements for both North American (USA and Canada) operation and worldwide (except USA and Canada) operation. The power supplies use standard industrial wiring with line-to-neutral or line-to-line power connections.

 **NOTE** Power for the optional –48-VDC power configuration is supplied by a centralized DC power plant instead of the AC power source in the cabinet. Refer to the associated manufacturer's documentation for specific DC power source requirements.

Keep this information in mind when you prepare the installation site for the drive tray:

- **Protective ground** – Site wiring must include a protective ground connection to the AC power source or the optional –48-VDC power source.

 **NOTE** *Protective ground* is also known as safety ground or chassis ground.

- **Circuit overloading** – Power circuits and associated circuit breakers must provide enough power and overload protection. To prevent damage to the drive tray, isolate its power source from large switching loads, such as air-conditioning motors, elevator motors, and factory loads.
- **Power interruptions** – The drive tray can withstand these applied voltage interruptions:
 - **Input transient** – 50 percent of the nominal voltage
 - **Duration** – One-half cycle
 - **Maximum frequency** – Once every 10 seconds
- **Power failures** – If a total power failure occurs, the drive tray automatically performs a power-on recovery sequence without operator intervention after the power is restored.

FC4600 Drive Tray Power Input

AC Power Input

Each power supply contains one 15-A slow-blow fuse.

AC Power Requirements for the FC4600 Drive Tray

| Parameter | Low Range | High Range |
|---|---------------|----------------|
| Nominal voltage | 90 to 136 VAC | 180 to 264 VAC |
| Frequency | 50 to 60 Hz | 50 to 60 Hz |
| Idle current | 3.78 A* | 1.98 A** |
| Maximum operating current | 3.90 A* | 2.06 A** |
| Maximum surge current (16-drive spin up) | 5.25 A* | 2.67 A** |
| *Typical current: 115 VAC, 60 Hz at 0.73 power supply efficiency and 0.96 power factor. **Typical current: 230 VAC, 60 Hz at 0.73 power supply efficiency and 0.96 power factor. | | |

DC Power Input

Nominal input voltages for the DC power source are as follows:

- Low range: –36 VDC
- High range: –72 VDC

The maximum operating current is 17 A.

FC4600 Drive Tray Power Factor Correction

Power factor correction is applied within the power-fan canister of each FC4600 drive tray, which maintains the power factor of the drive tray at greater than 0.99 with nominal input voltage.

FC4600 Drive Tray AC Power Cords and Receptacles

Each FC4600 drive tray is shipped with two AC power cords, which fit the standard AC outlets in the destination country. Each AC power cord connects one of the power-fan canisters in the drive tray to an independent, external AC power source, such as a wall receptacle, or to any uninterruptible power supply (UPS).

FC4600 Drive Tray Optional DC Power Connector Cables and Source Wires

The FC4600 drive tray is shipped with –48-VDC power connector cables if the DC power option is ordered. The –48-VDC power connector cable plugs into the DC power connector on the rear of the drive tray. The three source wires on the other end of the power connector cable connect the drive tray to centralized DC power plant equipment, typically through a bus bar above the cabinet.

⚠ WARNING (W12) Risk of electrical shock – This unit has more than one power source. To remove all power from the unit, all DC MAINS must be disconnected by removing all power connectors (item 4 below) from the power supplies.

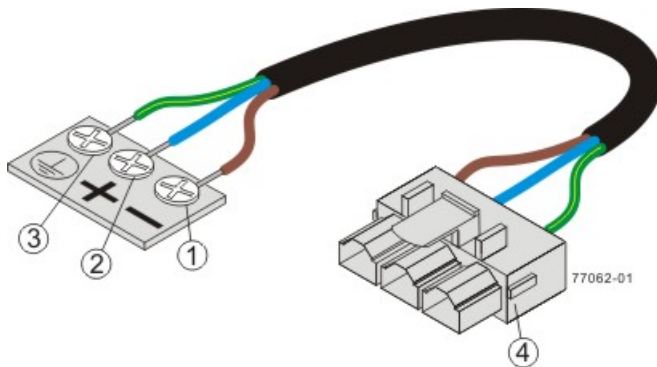

1. Supply (Negative), Brown Wire, -48 VDC
2. Return (Positive), Blue Wire
3. Ground, Green and Yellow Wire
4. DC Power Connector

⚠ WARNING (W14) Risk of bodily injury – A qualified service person is required to make the DC power connection according to NEC and CEC guidelines.

Two (or, optionally, four) DC power connector cables are provided with each drive tray. Two DC power connectors are on the two power-fan canisters on the rear of each drive tray if additional redundancy is required.

📌 NOTE It is not mandatory that you connect the second DC power connection on the power-fan canister of the drive tray. The second DC power connection is provided for additional redundancy only and can be connected to a second DC power bus.

Specifications of the AT2655 Drive Tray

The AT2655 drive tray contains Serial Advanced Technology Attachment (SATA) drives that provide storage in a Fibre Channel environment. Each AT2655 drive tray contains these components:

- Two to fourteen drives
- One or two environmental services monitor (ESM) canisters
- Two power supplies
- Two fans

AT2655 Drive Tray – Front View and Rear View

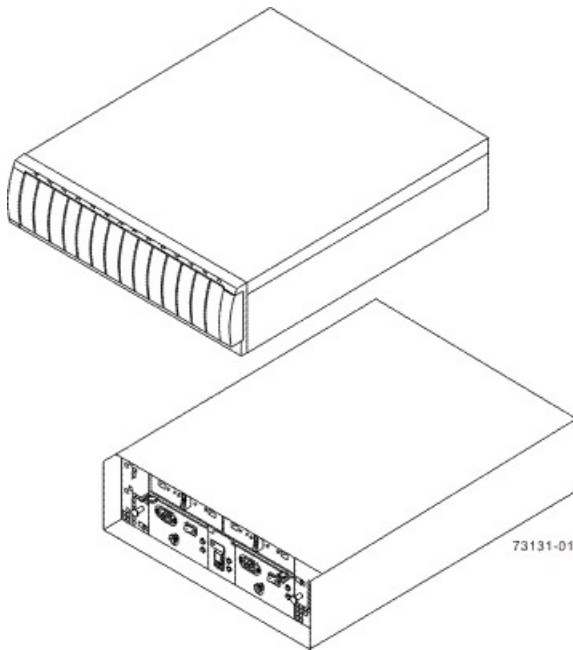

AT2655 Drive Tray Dimensions

A desktside model and a rackmount model of the AT2655 drive tray are available. The rackmount model conforms to the 48.3-cm (19.0-in.) rack standard.

Dimensions of the AT2655 Drive Tray (Deskside Model and Rackmount Model) – Front View

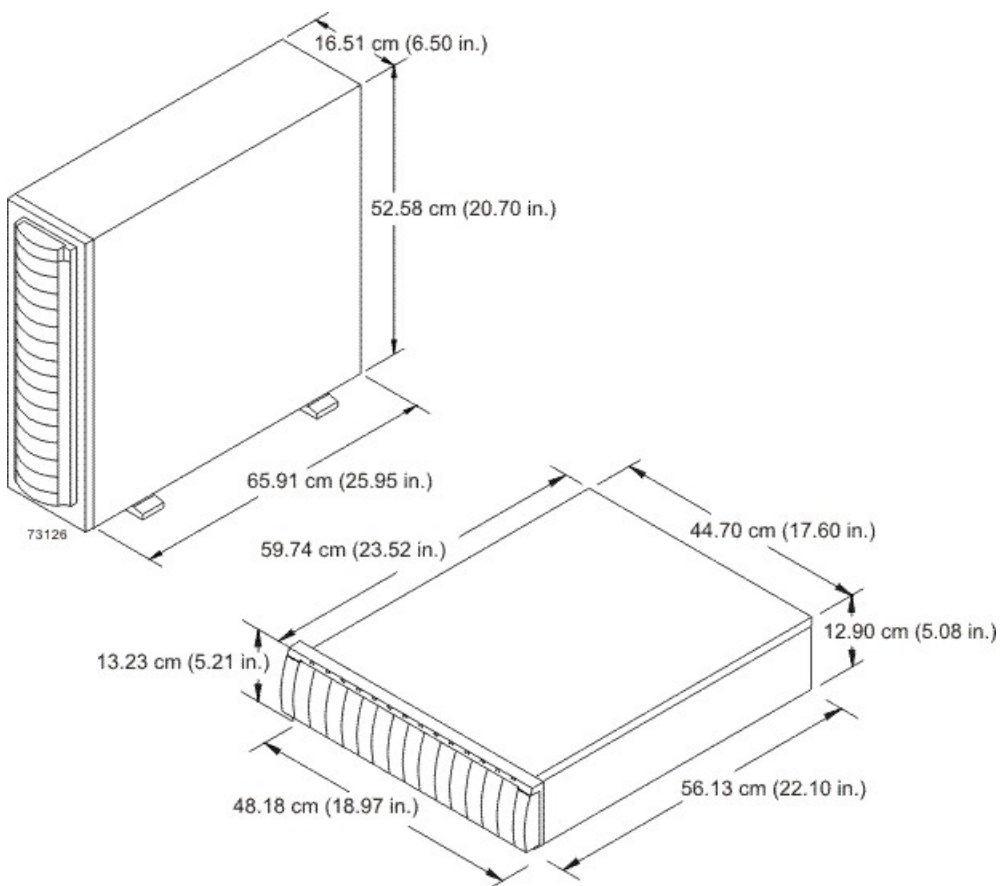

AT2655 Drive Tray Weight

Weights of the AT2655 Drive Tray

| Unit | Weight | | |
|------------------------------------|---------------------|--------------------|---------------------|
| | Maximum* | Empty** | Shipping*** |
| AT2655 drive tray, deskside model | 52.62 kg (116.0 lb) | 28.58 kg (63.0 lb) | 64.41 kg (142.0 lb) |
| AT2655 drive tray, rackmount model | 39.92 kg (88.0 lb) | 15.88 kg (35.0 lb) | 51.71 kg (114.0 lb) |

*Maximum weight indicates a drive tray with all of its drives and other components installed. Because drive weights can vary greatly, this value can vary from the value specified as much as 0.3 kg (0.6 lb) times the maximum number of drives per drive tray for drives weighing 1.0 kg (2.2 lb).

**Empty weight indicates a drive tray with the ESM canisters, the power supply canisters, the fan canisters, and the drives removed.

***Shipping weight indicates the maximum weight of a drive tray and all shipping material.

Component Weights of the AT2655 Drive Tray

| Component | Weight |
|-----------------------|-------------------------------|
| ESM canister | 1.678 kg (3.70 lb) |
| Power supply canister | 2.449 kg (5.40 lb) |
| Fan canister | 0.998 kg (2.20 lb) |
| Drive | Approximately 1.0 kg (2.2 lb) |

AT2655 Drive Tray Shipping Dimensions

Shipping Carton Dimensions for the AT2655 Drive Tray

| Height | Width | Depth |
|---|----------------------|----------------------|
| 44.45 cm (17.50 in.) – Includes the height of the pallet. | 62.23 cm (24.50 in.) | 74.93 cm (29.50 in.) |

AT2655 Drive Tray Temperature and Humidity

Temperature Requirements and Humidity Requirements for the AT2655 Drive Tray

| Condition | Parameter | Requirement |
|-------------------------------------|------------------------|--------------------------------|
| Temperature* | Operating range | 10°C to 40°C (50°F to 104°F) |
| | Maximum rate of change | 10°C (18°F) per hour |
| | Storage range | –10°C to 65°C (14°F to 149°F) |
| | Maximum rate of change | 15°C (27°F) per hour |
| | Transit range | –40°C to 65°C (–40°F to 149°F) |
| | Maximum rate of change | 20°C (36°F) per hour |
| Relative humidity (no condensation) | Operating range | 20% to 80% |
| | Storage range | 10% to 90% |
| | Transit range | 5% to 95% |
| | Maximum dew point | 26°C (79°F) |
| | Maximum gradient | 10% per hour |

| Condition | Parameter | Requirement |
|--|-----------|-------------|
| *If you plan to operate a system at an altitude between 1000 m to 3000 m (3280 ft to 9842 ft) above sea level, lower the environmental temperature 1.7°C (3.3°F) for every 1000 m (3280 ft) above sea level. | | |

AT2655 Drive Tray Altitude Ranges

Altitude Ranges for the AT2655 Drive Tray

| Environment | Altitude |
|-------------|---|
| Operating | 30.5 m (100 ft) below sea level to 3000 m (9842 ft) above sea level |
| Storage | 30.5 m (100 ft) below sea level to 3000 m (9842 ft) above sea level |
| Transit | 30.5 m (100 ft) below sea level to 12,000 m (40,000 ft) above sea level |

AT2655 Drive Tray Airflow and Heat Dissipation

Airflow goes from the front of the drive tray to the rear of the drive tray. Allow at least 76 cm (30 in.) of clearance in front of the drive tray and at least 61 cm (24 in.) of clearance behind the drive tray for service clearance, ventilation, and heat dissipation.

Airflow Through the AT2655 Drive Tray – Front View

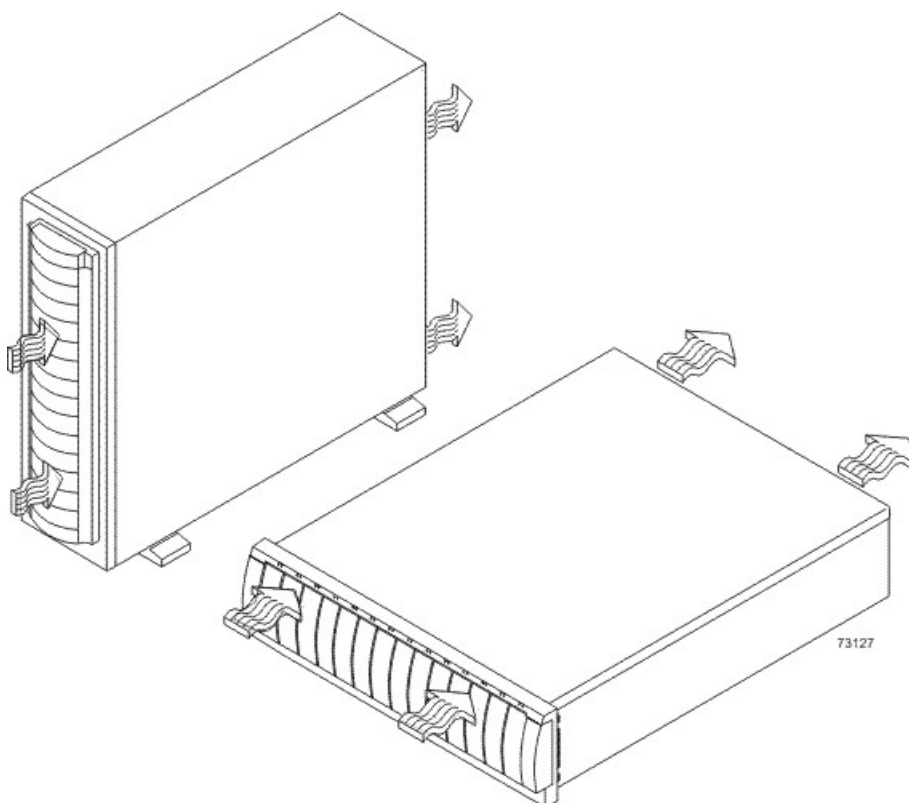

The tabulated power and heat dissipation values in the following table are the maximum measured operating power.

Power Ratings and Heat Dissipation for the AT2655 Drive Tray

| Unit | KVA | Watts (AC) | Btu/hr | Amps (240 VAC) |
|-------------------|-------|------------|--------|----------------|
| AT2655 drive tray | 0.329 | 316 | 1078 | 1.32 |

AT2655 Drive Tray Acoustic Noise

Sound Levels for the AT2655 Drive Tray

| Measurement | Level |
|----------------|----------|
| Sound power | 6.0 bels |
| Sound pressure | 60 dBA |

AT2655 Drive Tray Site Wiring and Power

The AT2655 drive tray uses wide-ranging, redundant power supplies that automatically accommodate voltages to the AC power source. The power supplies meet standard voltage requirements for both North American (USA and Canada) operation and worldwide (except USA and Canada) operation. The power supplies use standard industrial wiring with line-to-neutral or line-to-line power connections.

Keep this information in mind when you prepare the installation site for the drive tray:

- **Protective ground** – Site wiring must include a protective ground connection to the AC power source.



NOTE *Protective ground* is also known as safety ground or chassis ground.

- **Circuit overloading** – Power circuits and associated circuit breakers must provide enough power and overload protection. To prevent damage to the drive tray, isolate its power source from large switching loads, such as air-conditioning motors, elevator motors, and factory loads.
- **Power interruptions** – The drive tray can withstand these applied voltage interruptions:
 - **Input transient** – 50 percent of the nominal voltage
 - **Duration** – One-half cycle
 - **Maximum frequency** – Once every 10 seconds
- **Power failures** – If a total power failure occurs, the drive tray automatically performs a power-on recovery sequence without operator intervention after the power is restored.

AT2655 Drive Tray Power Input

Each power supply contains one 10-A slow-blow fuse.

AC Power Requirements for the AT2655 Drive Tray

| Parameter | Low Range | High Range |
|---|---------------|----------------|
| Nominal voltage | 90 to 136 VAC | 180 to 264 VAC |
| Frequency | 50 to 60 Hz | 50 to 60 Hz |
| Idle current | 2.65 A* | 1.31 A** |
| Maximum operating current | 2.78 A* | 1.43 A** |
| Maximum surge current | 4.00 A* | 2.03 A** |
| *Typical current: 115 VAC, 60 Hz at 0.73 power supply efficiency and 0.96 power factor. **Typical current: 230 VAC, 60 Hz at 0.73 power supply efficiency and 0.96 power factor. | | |

AT2655 Drive Tray Power Factor Correction

Power factor correction is applied within the power supply of each AT2655 drive tray, which maintains the power factor of the drive tray at greater than 0.99 with nominal input voltage.

AT2655 Drive Tray Power Cords and Receptacles

Each AT2655 drive tray is shipped with two AC power cords, which use the standard AC outlets in the destination country. Each AC power cord connects one of the power supplies in the drive tray to an independent, external AC power source, such as a wall receptacle, or to any uninterruptible power supply (UPS).

Specifications of the FC2610 Drive Tray

The FC2610 drive tray contains Fibre Channel drives that provide storage in a Fibre Channel environment. Each FC2610 drive tray contains these components:

- A maximum of 14 drives
- Two fan canisters
- Two power supply canisters
- One or two environmental services monitor (ESM) canisters

FC2610 Drive Tray – Front View and Rear View

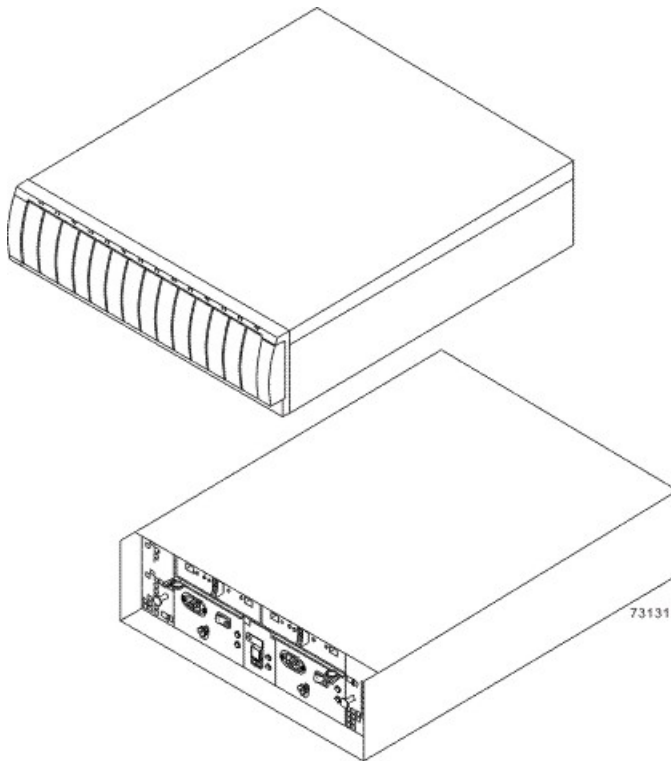

FC2610 Drive Tray Dimensions

A desktide model and a rackmount model of the FC2610 drive tray are available. The rackmount model conforms to the 48.3-cm (19.0-in.) rack standard.

Dimensions of the FC2610 Drive Tray(Deskside Model and Rackmount Model) – Front View

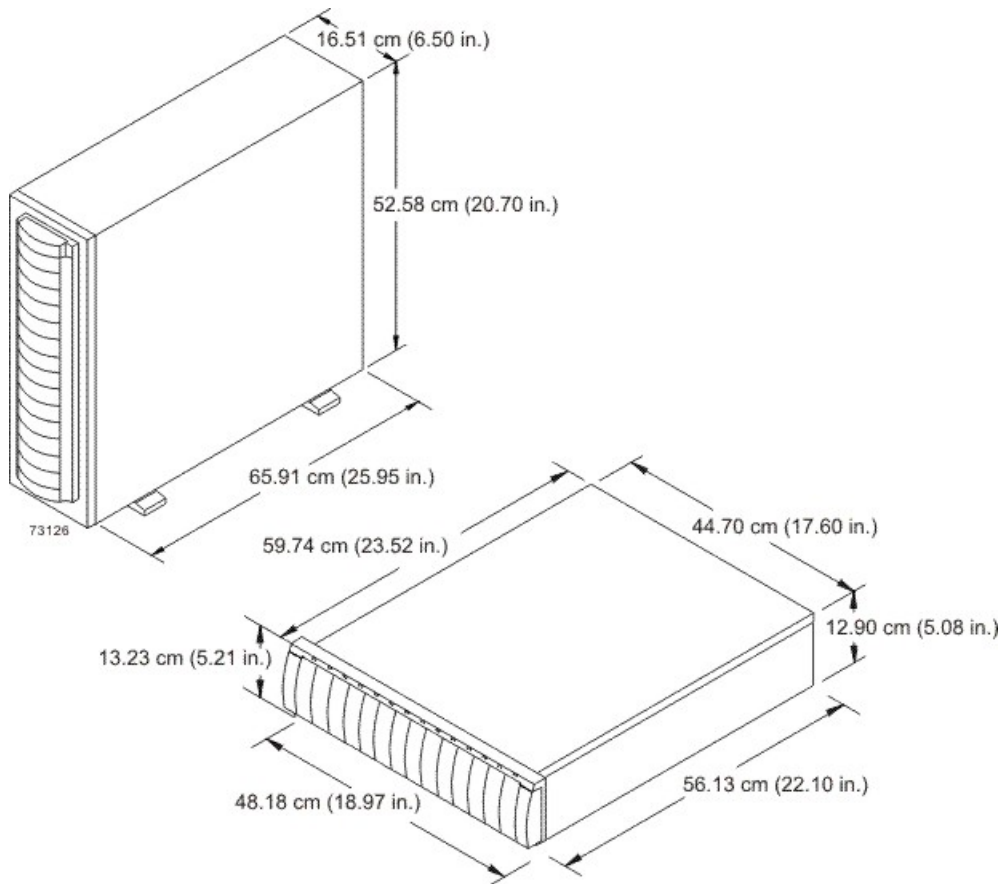

FC2610 Drive Tray Weight

Weights of the FC2610 Drive Tray

| Unit | Weight | | |
|------------------------------------|---------------------|--------------------|---------------------|
| | Maximum* | Empty** | Shipping*** |
| FC2610 drive tray, deskside model | 52.62 kg (116.0 lb) | 28.58 kg (63.0 lb) | 64.41 kg (142.0 lb) |
| FC2610 drive tray, rackmount model | 39.92 kg (88.0 lb) | 15.88 kg (35.0 lb) | 51.71 kg (114.0 lb) |

*Maximum weight indicates a drive tray with all of its drives and other components installed. Because drive weights can vary greatly, this value can vary from the value specified as much as 0.3 kg (0.6 lb) times the maximum number of drives per drive tray for drives weighing 1.0 kg (2.2 lb).

**Empty weight indicates a drive tray with the ESM canisters, the power-supply canisters, the fan canisters, and the drives removed.

***Shipping weight indicates the maximum weight of a drive tray and all shipping material.

Component Weights of the FC2610 Drive Tray

| Component | Weight |
|-----------------------|-------------------------------|
| ESM canister | 1.678 kg (3.70 lb) |
| Power supply canister | 2.449 kg (5.40 lb) |
| Fan canister | 0.998 kg (2.20 lb) |
| Drive | Approximately 1.0 kg (2.2 lb) |

FC2610 Drive Tray Shipping Dimensions

Shipping Carton Dimensions for the FC2610 Drive Tray

| Height | Width | Depth |
|---|----------------------|----------------------|
| 44.45 cm (17.50 in.) – Includes the height of the pallet. | 62.23 cm (24.50 in.) | 74.93 cm (29.50 in.) |

FC2610 Drive Tray Temperature and Humidity

Temperature Requirements and Humidity Requirements for the FC2610 Drive Tray

| Condition | Parameter | Requirement |
|-------------------------------------|------------------------|--------------------------------|
| Temperature* | Operating range | 10°C to 40°C (50°F to 104°F) |
| | Maximum rate of change | 10°C (18°F) per hour |
| | Storage range | –10°C to 65°C (14°F to 149°F) |
| | Maximum rate of change | 15°C (27°F) per hour |
| | Transit range | –40°C to 65°C (–40°F to 149°F) |
| | Maximum rate of change | 20°C (36°F) per hour |
| Relative humidity (no condensation) | Operating range | 20% to 80% |
| | Storage range | 10% to 90% |
| | Transit range | 5% to 95% |
| | Maximum dew point | 26°C (79°F) |
| | Maximum gradient | 10% per hour |

| Condition | Parameter | Requirement |
|--|-----------|-------------|
| *If you plan to operate a system at an altitude between 1000 m to 3000 m (3280 ft to 9842 ft) above sea level, lower the environmental temperature 1.7°C (3.3°F) for every 1000 m (3280 ft) above sea level. | | |

FC2610 Drive Tray Altitude Ranges

Altitude Ranges for the FC2610 Drive Tray

| Environment | Altitude |
|-------------|---|
| Operating | 30.5 m (100 ft) below sea level to 3000 m (9842 ft) above sea level |
| Storage | 30.5 m (100 ft) below sea level to 3000 m (9842 ft) above sea level |
| Transit | 30.5 m (100 ft) below sea level to 12,000 m (40,000 ft) above sea level |

FC2610 Drive Tray Airflow and Heat Dissipation

Airflow goes from the front of the drive tray to the rear of the drive tray. Allow at least 76 cm (30 in.) of clearance in front of the drive tray and at least 61 cm (24 in.) of clearance behind the drive tray for service clearance, ventilation, and heat dissipation.

Airflow Through the FC2610 Drive Tray – Front View

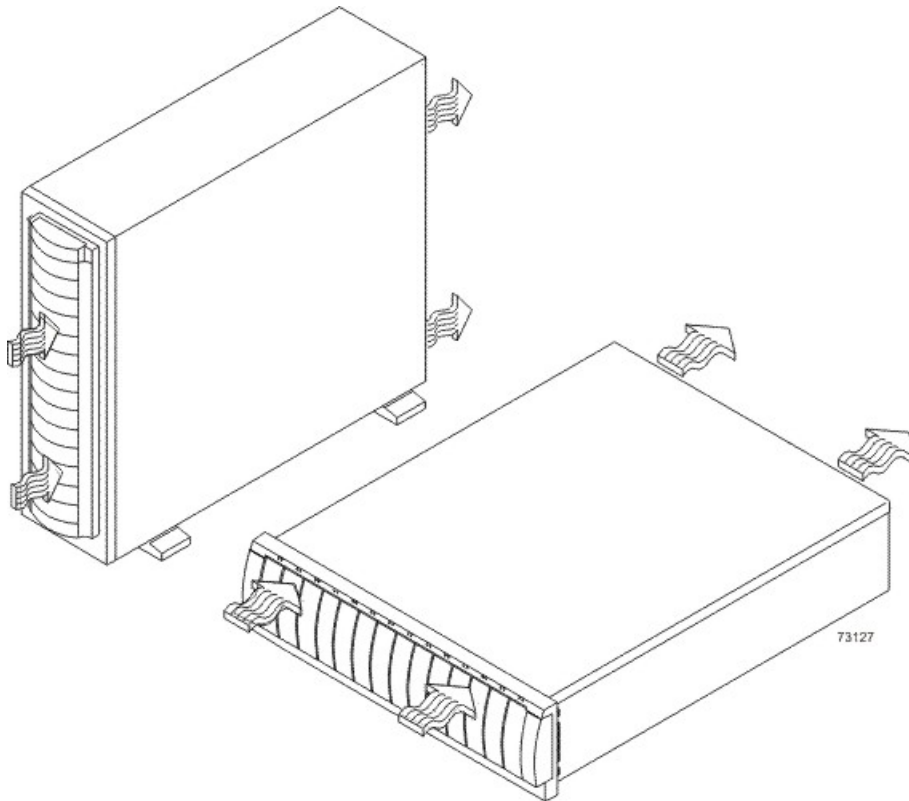

The tabulated power and heat dissipation values in the following table are the maximum measured operating power.

Power Ratings and Heat Dissipation for the FC2610 Drive Tray

| Unit | KVA | Watts (AC) | Btu/Hr | Amps (240 VAC) |
|-------------------|-------|------------|--------|----------------|
| FC2610 drive tray | 0.384 | 369 | 1259 | 1.54 |

FC2610 Drive Tray Acoustic Noise

Sound Levels for the FC2610 Drive Tray

| Measurement | Level |
|----------------|----------|
| Sound power | 6.0 bels |
| Sound pressure | 60 dBA |

FC2610 Drive Tray Site Wiring and Power

The FC2610 drive tray uses wide-ranging, redundant power supplies that automatically accommodate voltages to the AC power source. The power supplies meet standard voltage requirements for both North American (USA and Canada) operation and worldwide (except USA and Canada) operation. The power supplies use standard industrial wiring with line-to-neutral or line-to-line power connections.

Keep this information in mind when preparing the installation site for the drive tray:

- **Protective ground** – Site wiring must include a protective ground connection to the AC power source.



NOTE *Protective ground* is also known as safety ground or chassis ground.

- **Circuit overloading** – Power circuits and associated circuit breakers must provide enough power and overload protection. To prevent damage to the drive tray, isolate its power source from large switching loads, such as air-conditioning motors, elevator motors, and factory loads.
- **Power interruptions** – The drive tray can withstand these applied voltage interruptions:
 - **Input transient** – 50 percent of the nominal voltage
 - **Duration** – One-half cycle
 - **Maximum frequency** – Once every 10 seconds
- **Power failures** – If a total power failure occurs, the drive tray automatically performs a power-on recovery sequence without operator intervention after the power is restored.

FC2610 Drive Tray Power Input

The AC power sources must provide the correct voltage, current, and frequency specified on the tray and serial number label.

AC Power Requirements for the FC2610 Drive Tray

| Parameter | Low Range | High Range |
|---|-------------|-------------|
| Nominal voltage | 115 VAC | 230 VAC |
| Frequency | 50 to 60 Hz | 50 to 60 Hz |
| Idle current | 3.81 A* | 1.98 A** |
| Maximum operating current | 3.96 A* | 2.06 A** |
| Maximum surge current | 5.52 A* | 2.72 A** |
| *Typical current: 115 VAC, 60 Hz at 0.77 power supply efficiency and 0.96 power factor. **Typical current: 230 VAC, 60 Hz at 0.77 power supply efficiency and 0.96 power factor. | | |

FC2610 Drive Tray Power Factor Correction

Power factor correction is applied within the power supply of each FC2610 drive tray, which maintains the power factor of the drive tray at greater than 0.99 with nominal input voltage.

FC2610 Drive Tray Power Cords and Receptacles

Each FC2610 drive tray is shipped with two AC power cords, which use the standard AC outlets in the destination country. Each AC power cord connects one of the power supplies in the drive tray to an independent, external AC power source, such as a wall receptacle, or to any uninterruptible power supply (UPS).

Specifications of the FC2600 Drive Tray

The FC2600 drive tray is available as a rackmount model or a deskmount model that provides high-capacity disk storage for Fibre Channel environments. Each FC2600 drive tray contains these components:

- A maximum of 14 drives
- Two fan canisters
- Two power-supply canisters
- One or two environmental services monitor (ESM) canisters

FC2600 Drive Tray – Front View and Rear View

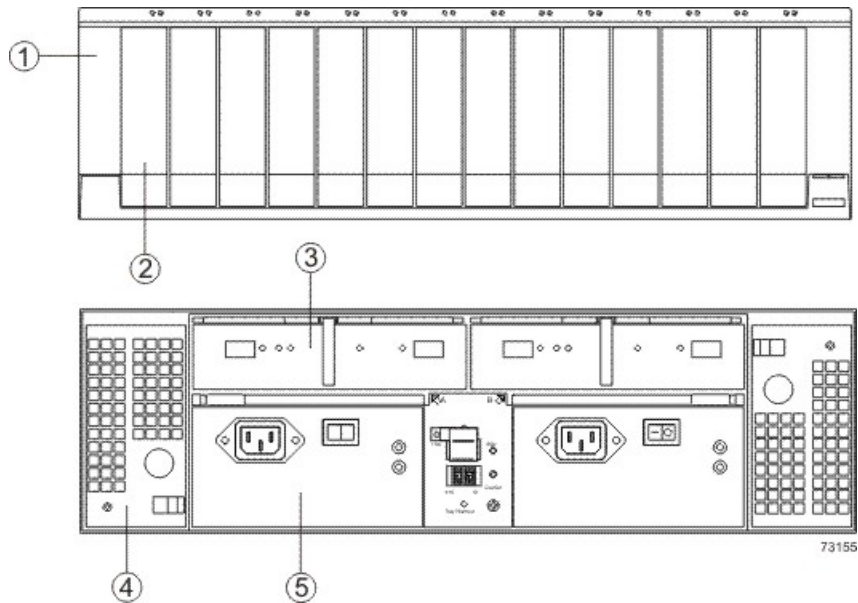

1. Bezel
2. Drive
3. ESM Canister
4. Fan Canister
5. Power Supply Canister

FC2600 Drive Tray Dimensions

Dimensions of the FC2600 Drive Tray (Deskside Model and Rackmount Model) – Front View

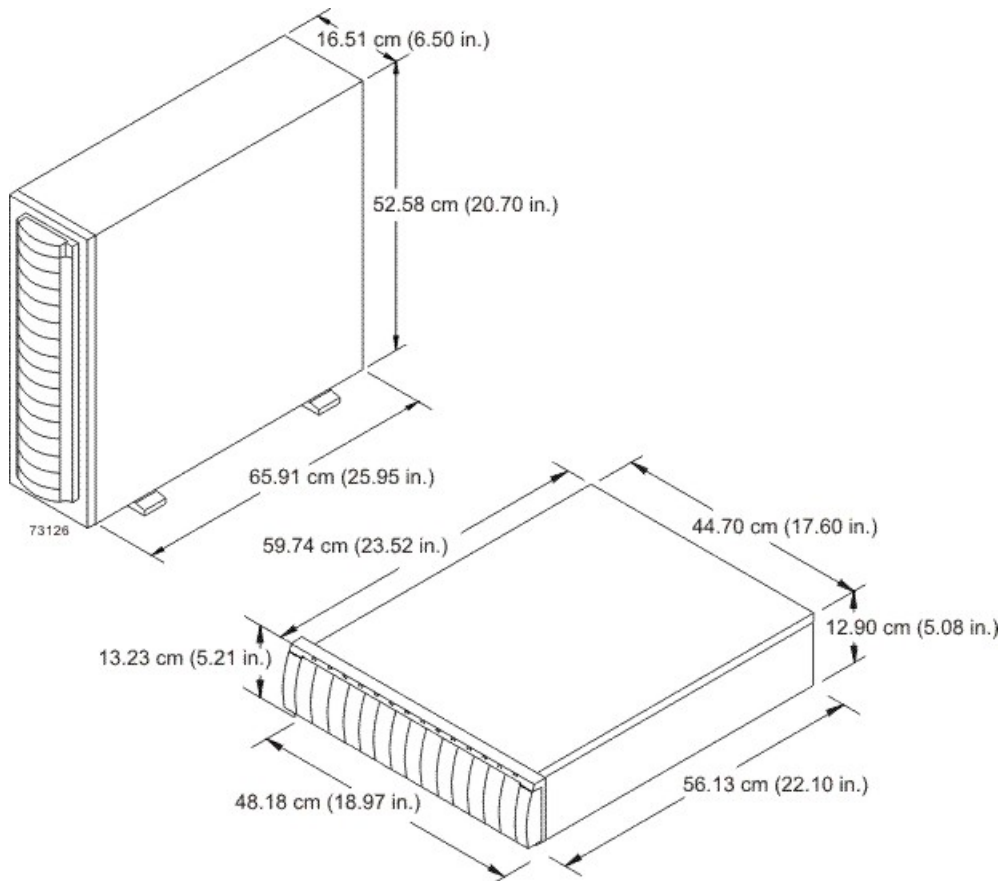

FC2600 Drive Tray Weight

Weights of the FC2600 Drive Tray

| Unit | Weight | | |
|------------------------------------|--------------------|-------------------|--------------------|
| | Maximum* | Empty** | Shipping*** |
| FC2600 drive tray, deskside model | 53.1 kg (117.0 lb) | 28.0 kg (63.0 lb) | 64.9 kg (143.0 lb) |
| FC2600 drive tray, rackmount model | 40.40 kg (89.0 lb) | 15.9 kg (35.0 lb) | 52.2 kg (115.0 lb) |

*Maximum weight indicates a drive tray with all of its drives and other components installed. Because drive weights can vary greatly, this value can vary from the value specified as much as 0.3 kg (0.6 lb) times the maximum number of drives per drive tray for drives weighing 1.0 kg (2.2 lb).

**Empty weight indicates a drive tray with the ESM canisters, the power-supply canisters, fan canisters, and drives removed.

***Shipping weight indicates the maximum weight of the drive tray and all shipping material.

Component Weights of the FC2600 Drive Tray

| Component | Weight |
|--------------|-------------------|
| Drive | 1.00 kg (2.2 lb) |
| ESM | 1.59 kg (3.7 lb) |
| Power supply | 2.45 kg (5.39 lb) |

FC2600 Drive Tray Temperature and Humidity

Temperature Requirements and Humidity Requirements for the FC2600 Drive Tray

| Condition | Parameter | Requirement |
|--|------------------------|--------------------------------|
| Temperature* | Operating range | 10°C to 40°C (50°F to 104°F) |
| | Maximum rate of change | 10°C (18°F) per hour |
| | Storage range | -10°C to 65°C (14°F to 149°F) |
| | Maximum rate of change | 15°C (27°F) per hour |
| | Transit range | -40°C to 65°C (-40°F to 149°F) |
| | Maximum rate of change | 15°C (27°F) per hour |
| Relative humidity (no condensation) | Operating range | 20% to 80% |
| | Storage range | 10% to 90% |
| | Transit range | 5% to 95% |
| | Maximum dew point | 26°C (79°F) |
| | Maximum gradient | 10% per hour |
| *If you plan to operate a system at an altitude between 1000 m to 3000 m (3280 ft to 9842 ft) above sea level, lower the environmental temperature 1.7°C (3.3°F) for every 1000 m (3280 ft) above sea level. | | |

FC2600 Drive Tray Altitude Ranges

Altitude Ranges for the FC2600 Drive Tray

| Environment | Altitude |
|-------------|---|
| Operating | 30.5 m (100 ft) below sea level to 3000 m (9842 ft) above sea level |

| Environment | Altitude |
|-------------|---|
| Storage | 30.5 m (100 ft) below sea level to 3000 m (9842 ft) above sea level |
| Transit | 30.5 m (100 ft) below sea level to 12,000 m (40,000 ft) above sea level |

FC2600 Drive Tray Airflow and Heat Dissipation

Allow at least 76 cm (30 in.) in front of the drive tray and at least 61 cm (24 in.) behind the drive tray for service clearance, ventilation, and heat dissipation.

Airflow Through the FC2600 Drive Tray

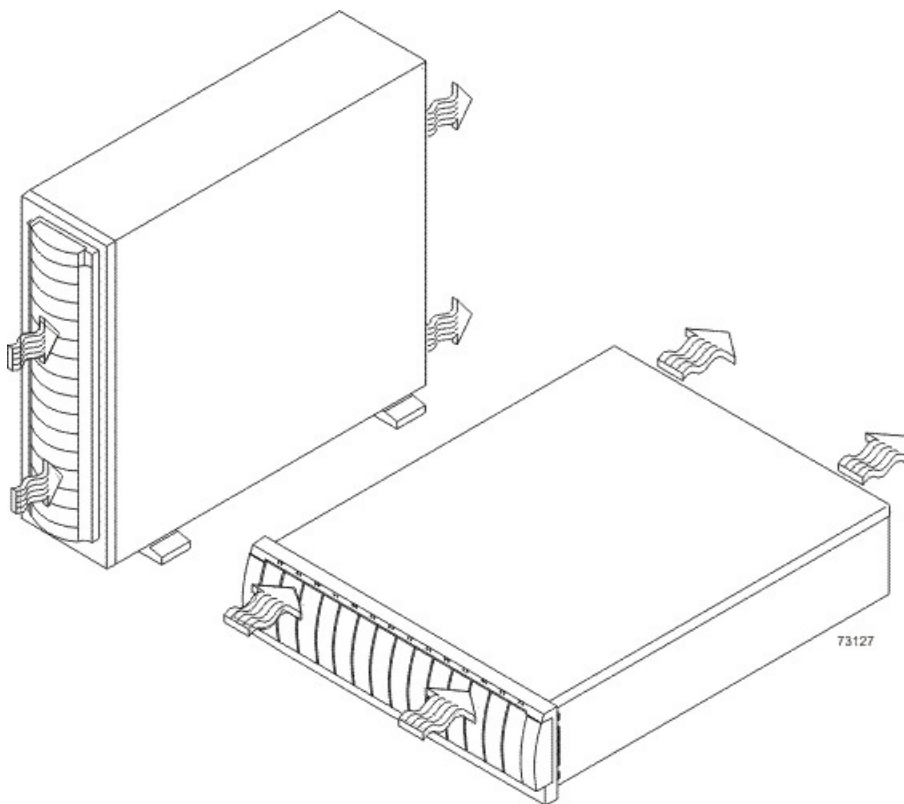

Power and Heat Dissipation for the FC2600 Drive Tray

| Unit | KVA | Watts (AC) | Btu per hour |
|-------------------|-------|------------|--------------|
| FC2600 drive tray | 0.375 | 366 | 1229 |

FC2600 Drive Tray Acoustic Noise

Sound Levels for the FC2600 Drive Tray

| Measurement | Level |
|----------------|----------|
| Sound power | 6.0 bels |
| Sound pressure | 60 dBA |

FC2600 Drive Tray Site Wiring and Power

The FC2600 drive tray uses wide-ranging, redundant power supplies that automatically accommodate voltages to the AC power source. The power supplies meet standard voltage requirements for both North American (USA and Canada) operation and worldwide (except USA and Canada) operation. The power supplies use standard industrial wiring with line-to-neutral or line-to-line power connections.

- **Protective ground** – Site wiring must include a protective ground connection to the AC power source.



NOTE Protective ground is also known as safety ground or chassis ground.

- **Circuit overloading** – Power circuits and associated circuit breakers must provide enough power and overload protection. To prevent damage to the drive tray, isolate its power source from large switching loads, such as air-conditioning motors, elevator motors, and factory loads.
- **Power interruptions** – The drive tray can withstand these applied voltage interruptions:
 - **Input transient** – 50 percent of the nominal voltage
 - **Duration** – One-half cycle
 - **Frequency** – Once every 10 seconds
- **Power failures** – If a total power failure occurs, the drive tray automatically performs a power-on recovery sequence without operator intervention.

FC2600 Drive Tray Power Input

Each power supply contains one 10-A slow-blow fuse.

AC Power Requirements for the FC2600 Drive Tray

| Parameter | Low Range | High Range |
|---|---------------|----------------|
| Nominal voltage | 90 to 136 VAC | 180 to 264 VAC |
| Frequency | 50 to 60 Hz | 50 to 60 Hz |
| Idle current | 2.93 A* | 1.27 A** |
| Maximum operating current | 3.18 A | 1.37 A |
| Maximum surge current | 5.85 A | 2.36 A |
| *Typical current: 115 VAC, 60 Hz at 0.73 power supply efficiency and 0.96 power factor. | | |

| Parameter | Low Range | High Range |
|--|-----------|------------|
| **Typical current: 230 VAC, 60 Hz at 0.73 power supply efficiency and 0.96 power factor. | | |

FC2600 Drive Tray Power Correction Factor

Power factor correction is applied within the power supply of each FC2600 drive tray, which maintains the power factor of the drive tray at greater than 0.99 with nominal input voltage.

FC2600 Drive Tray AC Power Cords and Receptacles

Each FC2600 drive tray is shipped with two AC power cords that are appropriate for use in a typical outlet in the destination country. Each AC power cord connects one of the power supplies in a drive tray to an independent, external AC power source, such as a wall receptacle or a UPS.

If you have a cabinet with internal power cabling, such as a ladder cord, you do not need the AC power cords that are shipped with the drive tray.

Specifications of the DM1300 Drive Tray

The DM1300 drive tray contains Serial Attached SCSI (SAS) drives. Each DM1300 drive tray contains these components:

- A maximum of 12 drives
- Two power-supply fan canisters
- One or two environmental services monitor (ESM) canisters

DM1300 Drive Tray – Front View

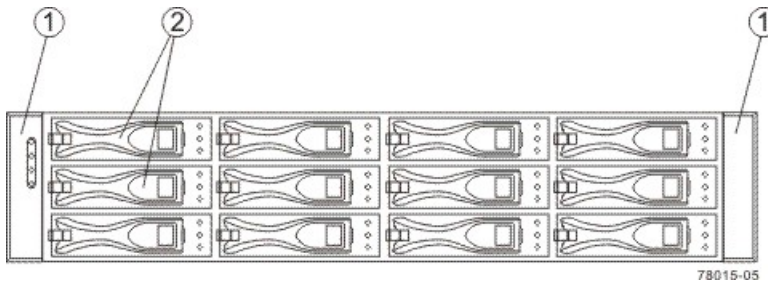

1. End Caps (the Left End Cap has the Drive Tray LEDs)
2. Drive Canisters

DM1300 Drive Tray – Rear View

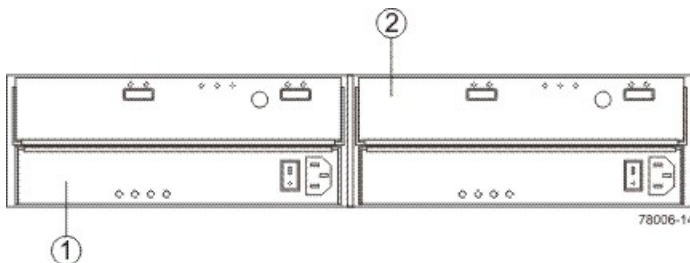

1. Power-Fan Canister
2. ESM Canister

Usually, an AC power source supplies power to the power-fan canister. A DC poweroption is also available.

DM1300 Drive Tray Power Source Options – Rear View

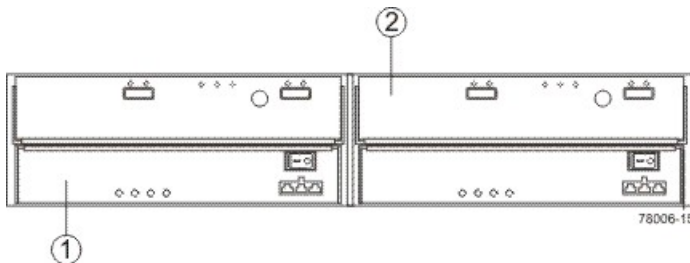

1. Controller Canister
2. DC Power Switch on an Optional Power-Fan Canister

DM1300 Drive Tray Dimensions

The DM1300 drive tray conforms to the 48.3-cm (19.0-in.) rack standard.

Dimensions of the DM1300 Drive Tray – Front View

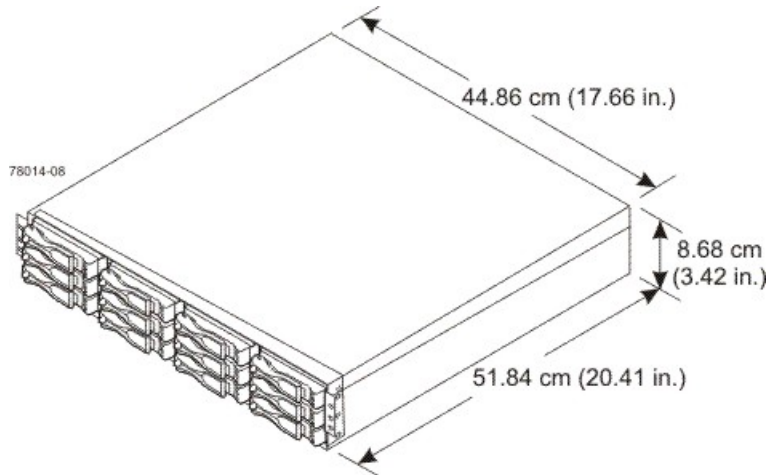

DM1300 Drive Tray Weight

Weights of the DM1300 Drive Tray

| Unit | Weight | | |
|-------------------|--------------------|-------------------|--------------------|
| | Maximum* | Empty** | Shipping*** |
| DM1300 drive tray | 25.86 kg (57.0 lb) | 6.80 kg (15.0 lb) | 25.00 kg (55.0 lb) |

*Maximum weight indicates a drive tray with all of its drives and other components installed. Because drive weights can vary greatly, this value can vary from the value specified as much as 0.3 kg (0.6 lb) times the maximum number of drives per drive tray for drives weighing 1.0 kg (2.2 lb).

**Empty weight indicates a drive tray with the ESM canisters, the power-fan canisters, and the drives removed.

***Shipping weight indicates the maximum weight of a fully-populated drive tray and all shipping material.

Component Weights of the DM1300 Drive Tray

| Component | Weight |
|--------------------|-------------------------------|
| ESM canister | 0.907 kg (2.00 lb) |
| Power-fan canister | 2.267 kg (5.00 lb) |
| Drive | Approximately 1.0 kg (2.2 lb) |

DM1300 Drive Tray Shipping Dimensions

Shipping Carton Dimensions for the DM1300 Drive Tray

| Height | Width | Depth |
|----------------------|----------------------|----------------------|
| 25.40 cm (10.00 in.) | 60.76 cm (24.00 in.) | 44.86 cm (78.74 in.) |

DM1300 Drive Tray Temperature and Humidity

Temperature Requirements and Humidity Requirements for the DM1300 Drive Tray

| Condition | Parameter | Requirement |
|--|------------------------|--------------------------------|
| Temperature* | Operating range | 10°C to 40°C (50°F to 104°F) |
| | Maximum rate of change | 10°C (18°F) per hour |
| | Storage range | -10°C to 50°C (14°F to 122°F) |
| | Maximum rate of change | 15°C (27°F) per hour |
| | Transit range | -40°C to 60°C (-40°F to 140°F) |
| | Maximum rate of change | 20°C (36°F) per hour |
| Relative humidity (no condensation) | Operating range | 20% to 80% |
| | Storage range | 10% to 90% |
| | Transit range | 5% to 95% |
| | Maximum dew point | 26°C (79°F) |
| | Maximum gradient | 10% per hour |
| *If you plan to operate a system at an altitude between 1000 m to 3000 m (3280 ft to 9842 ft) above sea level, lower the environmental temperature 1.7°C (3.3°F) for every 1000 m (3280 ft) above sea level. | | |

DM1300 Drive Tray Altitude Ranges

Altitude Ranges for the DM1300 Drive Tray

| Environment | Altitude |
|-------------|---|
| Operating | 30.5 m (100 ft) below sea level to 3000 m (9842 ft) above sea level |
| Storage | 30.5 m (100 ft) below sea level to 3000 m (9842 ft) above sea level |

| Environment | Altitude |
|-------------|---|
| Transit | 30.5 m (100 ft) below sea level to 12,000 m (40,000 ft) above sea level |

DM1300 Drive Tray Airflow and Heat Dissipation

Airflow goes from the front of the drive tray to the rear of the drive tray. Allow at least 76 cm (30 in.) of clearance in front of the drive tray and at least 61 cm (24 in.) of clearance behind the drive tray for service clearance, ventilation, and heat dissipation.

Airflow Through the DM1300 Drive Tray – Front View

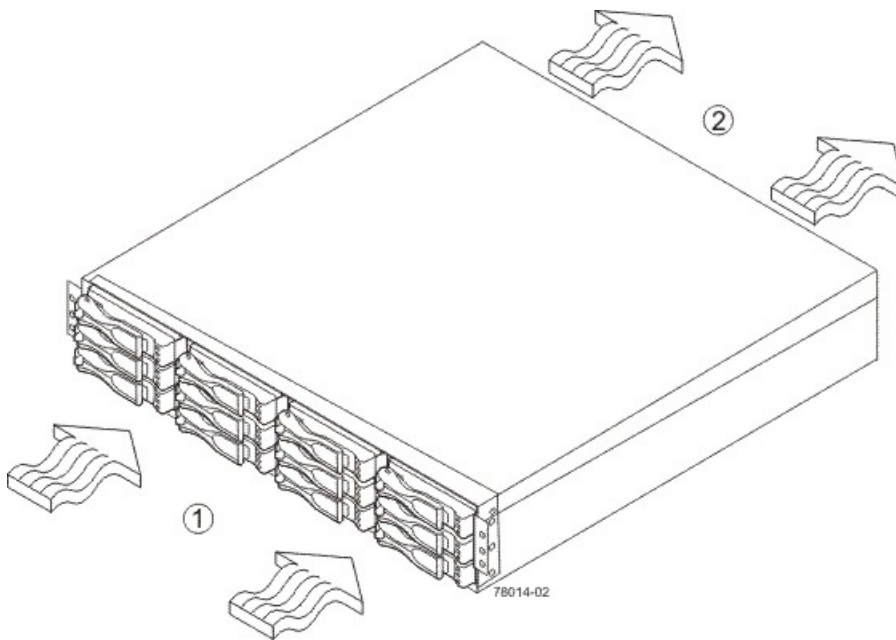

1. 76 cm (30 in.) clearance in front of the cabinet
2. 61 cm (24 in.) clearance behind the cabinet

The tabulated power and heat dissipation values in the following table are the maximum measured operating power.

Power Ratings and Heat Dissipation for the DM1300 Drive Tray

| Unit | KVA | Watts (AC) | Btu/Hr | Amps (240 VAC) |
|-------------------|-------|------------|--------|----------------|
| DM1300 drive tray | 0.362 | 358 | 1224 | 1.54 |

DM1300 Drive Tray Acoustic Noise

Sound Levels for the DM1300 Drive Tray

| Measurement | Level |
|---------------------------------|-----------------|
| ES 2-10-02 Standard Level 2 | 0.5 bels margin |
| Sound power (standby operation) | 6.5 bels |
| Sound power (normal operation) | 6.8 bels |

DM1300 Drive Tray Site Wiring and Power

The DM1300 drive tray uses wide-ranging, redundant power supplies that automatically accommodate voltages to the AC power source. The power supplies meet standard voltage requirements for both North American (USA and Canada) operation and worldwide (except USA and Canada) operation. The power supplies use standard industrial wiring with line-to-neutral or line-to-line power connections.

Keep this information in mind when preparing the installation site for the drive tray:

- **Protective ground** – Site wiring must include a protective ground connection to the AC power source.



NOTE *Protective ground* is also known as safety ground or chassis ground.

- **Circuit overloading** – Power circuits and associated circuit breakers must provide enough power and overload protection. To prevent damage to the drive tray, isolate its power source from large switching loads, such as air-conditioning motors, elevator motors, and factory loads.
- **Power interruptions** – The drive tray can withstand these applied voltage interruptions:
 - **Input transient** – 50 percent of the nominal voltage
 - **Duration** – One-half cycle
 - **Maximum frequency** – Once every 10 seconds
- **Power failures** – If a total power failure occurs, the drive tray automatically performs a power-on recovery sequence without operator intervention after the power is restored.

DM1300 Drive Tray Power Input

AC Power Input

The AC power sources must provide the correct voltage, current, and frequency specified on the tray and serial number label.

AC Power Requirements for the DM1300 Drive Tray

| Parameter | Low Range | High Range |
|-----------------|-------------|-------------|
| Nominal voltage | 100 VAC | 240 VAC |
| Frequency | 50 to 60 Hz | 50 to 60 Hz |

| Parameter | Low Range | High Range |
|--|-----------|------------|
| Idle current | 3.96 A* | 1.74 A** |
| Maximum operating current | 4.08 A* | 1.70 A** |
| <p>*Typical current: 100 VAC, 60 Hz at 0.77 power supply efficiency and 0.96 power factor. These numbers can vary significantly, depending upon the drives tested in the particular configuration.</p> <p>**Typical current: 240 VAC, 60 Hz at 0.77 power supply efficiency and 0.96 power factor. These numbers can vary significantly, depending upon the drives tested in the particular configuration.</p> | | |

DC Power Input

Nominal input voltages for the DC power source are as follows:

- Low range: –36 VDC
- High range: –72 VDC

The maximum operating current is 17 A.

DM1300 Drive Tray Power Factor Correction

Power factor correction is applied within the power supply of each DM1300 drive tray, which maintains the power factor of the drive tray at greater than 0.95 with nominal input voltage.

DM1300 Drive Tray AC Power Cords and Receptacles

Each DM1300 drive tray is shipped with two AC power cords, which use standard AC outlets in the destination country. Each AC power cord connects one of the power supplies in the drive tray to an independent, external AC power source, such as a wall receptacle, or to any uninterruptible power supply (UPS).

Usually an AC power source supplies power to the power-fan canister. A DC power option is also available. For more information about the DC power option, see [“DM1300 Drive Tray Optional DC Power Connector Cables and Source Wires.”](#)

DM1300 Drive Tray Optional DC Power Connector Cables and Source Wires

The DM1300 drive tray is shipped with –48-VDC power connector cables if the DC power option is ordered. The –48-VDC power connector cable plugs into the DC power connector on the rear of the drive tray. The three source wires on the other end of the power connector cable connect the drive tray to centralized DC power plant equipment, typically through a bus bar above the cabinet.



WARNING (W12) Risk of electrical shock – This unit has more than one power source. To remove all power from the unit, all DC MAINS must be disconnected by removing all power connectors (item 4 below) from the power supplies.

1. Supply (Negative), Brown Wire, -48 VDC
2. Return (Positive), Blue Wire
3. Ground, Green and Yellow Wire
4. DC Power Connector



WARNING (W14) Risk of bodily injury – A qualified service person is required to make the DC power connection according to NEC and CEC guidelines.

Two DC power connector cables are provided with each drive tray. Two DC power connectors are on the two power-fan canisters on the rear of each drive tray if additional redundancy is required.



NOTE It is not mandatory that you connect the second DC power connection on the power-fan canister of the drive tray. The second DC power connection is provided for additional redundancy only and can be connected to a second DC power bus.

Regulatory Compliance Statements

FCC Radio Frequency Interference Statement

This equipment has been tested and found to comply with the limits for a Class A digital device, pursuant to Part 15 of the Federal Communications Commission (FCC) Rules. These limits are designed to provide reasonable protection against harmful interference in a commercial installation. This equipment generates, uses, and can radiate radio frequency energy and, if not installed and used in accordance with the instructions, may cause harmful interference to radio communications. Operation of this equipment in a residential area is likely to cause harmful interference, in which case the user will be required to correct the interference at his/her own expense.

LSI Corporation is not responsible for any radio or television interference caused by unauthorized modification of this equipment or the substitution or attachment of connecting cables and equipment other than those specified by LSI. It is the user's responsibility to correct interference caused by such unauthorized modification, substitution, or attachment.

Laser Products Statement

This equipment uses Small Form-factor Pluggable (SFP) optical transceivers, which are unmodified Class 1 laser products pursuant to 21 CFR, Subchapter J, Section 1040.10. All optical transceivers used with this product are required to be 21 CFR certified Class 1 laser products. For outside the USA, this equipment has been tested and found compliant with Class 1 laser product requirements contained in European Normalization standard EN 60825-1 1994+A11. Class 1 levels of laser radiation are not considered to be hazardous and are considered safe based upon current medical knowledge. This class includes all lasers or laser systems which cannot emit levels of optical radiation above the exposure limits for the eye under any exposure conditions inherent in the design of the laser products.

LSI Corporation is not responsible for any damage or injury caused by unauthorized modification of this equipment or the substitution or attachment of connecting cables and equipment other than those specified by LSI. It is the user's responsibility to correct interference caused by such unauthorized modification, substitution, or attachment.

This Class A digital apparatus meets all requirements of the Canadian Interference-Causing Equipment Regulations.

Cet appareil numérique de la classé A respecte toutes les exigences du Règlement sur le matériel brouilleur du Canada.

この装置は、第一種情報装置（商工業地域において使用されるべき情報装置）で商工業地域での電波障害防止を目的とした情報処理装置等電波障害自主規制協議会（VCCI）基準に適合しております。

従って、住宅地域またはその隣接した地域で使用すると、ラジオ、テレビジョン受信機等に受信障害を与えることがあります。

取扱説明書に従って正しい取り扱いをして下さい。

CDE2600 Controller-Drive Tray Installation

This topic provides basic information for installing the CDE2600 controller-drive tray and the corresponding drive trays (the DE1600 drive tray and the DE5600 drive tray) in a storage array. After you have completed these tasks, go to the *Initial Configuration and Software Installation* electronic document topics or the PDF on the SANtricity ES Storage Manager Installation DVD.

Step 1 – Preparing for a CDE2600 Controller-Drive Tray Installation

Storage arrays for 6-Gb/s SAS drives consist of a CDE2600 controller-drive tray, or a CDE2600 controller-drive tray and one or more DE1600 or DE5600 drive trays in a cabinet. Use this document to install the CDE2600 controller-drive trays and all necessary drive trays for your configuration.

The following table shows the various configuration options.

CDE2600 Controller-Drive Tray Options

| CDE2600 Configurations | Options |
|--|--|
| Simplex (one controller) CDE2600 controller-drive tray with no host interface card | <p>A maximum of 96 drives that you can upgrade to 192. The upgrade is a Premium feature.</p> <p>Any combination of CDE2600 controller-drive trays attached to DE1600 drive trays or DE5600 drive trays, not to exceed a maximum of 96 (or 192) drive slots in the storage array.</p> <p>Two 6-Gb/s host connectors.</p> <p>8-GB battery backup.</p> |
| Simplex CDE2600 controller-drive tray with a host interface card | <p>A maximum of 96 drives that you can upgrade to 192. The upgrade is a Premium feature.</p> <p>Any combination of CDE2600 controller-drive trays attached to DE1600 drive trays or DE5600 drive trays, not to exceed a maximum of 96 (or 192) drive slots in the storage array.</p> <p>Two 6-Gb/s host connectors, in addition to one of the following host interface cards:</p> <ul style="list-style-type: none"> ▪ Two 6-Gb/s SAS connectors ▪ Four 1-Gb/s iSCSI connectors ▪ Two 10-Gb/s iSCSI connectors ▪ Four 8-Gb/s Fibre Channel (FC) connectors <p>8-GB battery backup.</p> |
| Duplex (two controllers) CDE2600 controller-drive tray without a host interface card | <p>A maximum of 96 drives that you can upgrade to 192. The upgrade is a Premium feature.</p> <p>Any combination of CDE2600 controller-drive trays attached to DE1600 drive trays or DE5600 drive trays, not to exceed a maximum of 96 (or 192) drive slots in the storage array.</p> <p>Two 6-Gb/s host connectors.</p> <p>8-GB battery backup.</p> |
| Duplex CDE2600 controller-drive tray with a host interface card | <p>A maximum of 96 drives that you can upgrade to 192. The upgrade is a Premium feature.</p> <p>Any combination of CDE2600 controller-drive trays attached to DE1600 drive trays or DE5600 drive trays, not to exceed a maximum of 96 (or 192) drive slots in the storage array.</p> <p>Two 6-Gb/s host connectors, in addition to one of the following host interface cards:</p> <ul style="list-style-type: none"> ▪ Two 6-Gb/s SAS connectors |

| CDE2600 Configurations | Options |
|------------------------|--|
| | <ul style="list-style-type: none"> ▪ Four 1-Gb/s iSCSI connectors ▪ Two 10-Gb/s iSCSI connectors ▪ Four 8-Gb/s FC connectors 8-GB battery backup. |

 **ATTENTION Possible hardware damage** – To prevent electrostatic discharge damage to the tray, use proper antistatic protection when handling tray components.

Key Terms

storage array

A collection of both physical components and logical components for storing data. Physical components include drives, controllers, fans, and power supplies. Logical components include volume groups and volumes. These components are managed by the storage management software.

controller-drive tray

One tray with drives, one or two controllers, fans, and power supplies. The controller-drive tray provides the interface between a host and a storage array.

controller

A circuit board and firmware that is located within a controller tray or a controller-drive tray. A controller manages the input/output (I/O) between the host system and data volumes.

drive tray

One tray with drives, one or two environmental services monitors (ESMs), power supplies, and fans. A drive tray does not contain controllers.

environmental services monitor (ESM)

A canister in the drive tray that monitors the status of the components. An ESM also serves as the connection point to transfer data between the drive tray and the controller.

Small Form-factor Pluggable (SFP) transceiver

A component that enables Fibre Channel duplex communication between storage array devices. SFP transceivers can be inserted into host bus adapters (HBAs), controllers, and environmental services monitors (ESMs). SFP transceivers can support either copper cables (the SFP transceiver is integrated with the cable) or fiber-optic cables (the SFP transceiver is a separate component from the fiber-optic cable).





Gathering Items

Before you start installing the controller-drive tray, you must have installed the cabinet in which the controller-drive tray will be mounted.

Use the tables in this section to verify that you have all of the necessary items to install the controller-drive tray.

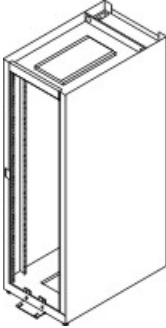
Basic Hardware

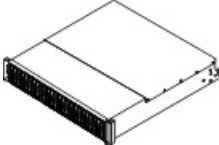
Basic Hardware



| | Item | Included with the Controller-Drive Tray |
|---|---|---|
|  | <p>Cabinet</p> <ul style="list-style-type: none"> Make sure that your cabinet meets the installation site specifications of the various CDE2600 storage array components. Refer to the <i>Storage System Site Preparation Guide</i> for more information. Depending on the power supply limitations of your cabinet, you might need to install more than one cabinet to accommodate the different components of the CDE2600 storage array. Refer to the installation guide for your cabinet for instructions on installing the cabinet. | |
|  | DE1600 drive tray with end caps that are packaged separately. | ✓ |
|  | DE5600 drive tray with end caps that are packaged separately. | ✓ |
|  | <p>Mounting rails and screws</p> <p>The mounting rails that are available with the drive tray are designed for an industry-standard cabinet.</p> | |
| | Fibre Channel switch (optional) SAS switch (optional) | |
| | Gigabit Ethernet switch (optional) | |

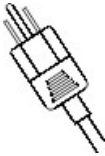

| | Item | Included with the Controller-Drive Tray |
|--|--|---|
| | <ul style="list-style-type: none"> ▪ Host with Fibre Channel host bus adapters (HBAs) (optional) ▪ Host with iSCSI HBAs (optional) or a network interface card (optional) ▪ Host with SAS HBAs (optional) | |

CDE2600 Configuration Cables and Connectors

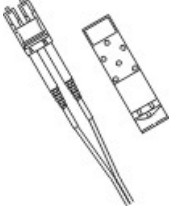
Cables and Connectors

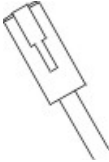
| | Item | Included with the Controller-Drive Tray or Drive Trays |
|--|---|--|
|  | <p>AC power cords.</p> <p>The controller-drive tray and the drive trays ship with power cords for connecting to an external power source, such as a wall plug. Your cabinet might have special power cords that you use instead of the power cords that ship with the controller-drive tray and the drive trays.</p> | ✓ |
| | <p>(Optional) Two DC power connector cables are provided with each drive tray for connection to centralized DC power plant equipment.</p> <ul style="list-style-type: none"> ▪ Four DC power connector cables are provided if additional redundancy is required. ▪ A qualified service person is required to make the DC power connection per NEC and CEC guidelines. A two-pole 20-amp circuit breaker is required between the DC power source and the drive tray for over-current and short-circuit protection. Before turning off any power switches on a DC-powered drive tray, first you must disconnect the two-pole 20-amp circuit breaker. | ✓ For the DC power option only |
| | <p>Copper SAS cables - Use for all drive-side connections within the storage array.</p> <p>Fiber-optic cables - Use for FC connections to the drive trays.</p> <p>For the differences between the fiber-optic cables and the copper Fibre Channel (FC) cables, see Things to Know – SFP Transceivers, Fiber-Optic Cables, Copper Cables, and SAS Cables .</p> | |

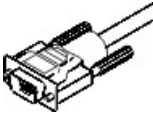
| | Item | Included with the Controller-Drive Tray or Drive Trays |
|---|---|---|
|  | <p>Small Form-factor Pluggable (SFP) transceivers</p> <ul style="list-style-type: none"> ▪ The SFP transceivers connect fiber-optic cables to host ports and drive ports. ▪ Four or eight SFP transceivers are included with the controller-drive tray; one for each of the host channel ports on the controllers. ▪ Depending on your connection requirements, you might need to purchase additional SFP transceivers (two SFP transceivers for each fiber-optic cable). ▪ Depending on the configuration of your storage array, you might need to use various combinations of four different types of SFP transceivers: 8-Gb/s Fibre Channel, 6-Gb/s SAS, 1-Gb/s iSCSI, or 10-Gb/s iSCSI. These SFP transceivers are not generally interchangeable. ▪ You must purchase <i>only</i> Restriction of Hazardous Substances (RoHS)-compliant SFP transceivers. |  |
| | <p>Copper Fibre Channel cables (optional) Use these cables for connections within the storage array. For the differences between the fiber-optic cables and the copper Fibre Channel cables, see “Things to Know – SFP Transceivers, Fiber-Optic Cables, Copper Cables, and SAS Cables.”</p> |  |
|  | <p>Ethernet cable This cable is used for out-of-band storage array management and for 1-Gb/s iSCSI connections. For information about out-of-band storage array management, see the description for "Deciding on the Management Method" in <i>Initial Configuration and Software Installation</i> electronic document topics or the PDF on the SANtricity ES Storage Manager Installation DVD.</p> | |

| | Item | Included with the Controller-Drive Tray or Drive Trays |
|--|---|--|
|  | <p>SAS cables</p> <p>The SAS cables connect the host to the controller-drive tray. If you install a drive tray, you must use SAS cables to connect the controller-drive tray to the drive tray.</p> | |
|  | <p>Serial cable</p> <p>This cable is used for support only. You do not need to connect it during initial installation.</p> | |
|  | <p>DB9-to-PS2 adapter cable</p> <p>This cable adapts the DB9 connector on commercially available serial cables to the PS2 connector on the controller.</p> | |

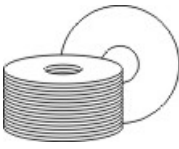

Product DVDs

Product DVDs

| | Item | Included with the Controller-Drive Tray |
|---|---|---|
|  | <p>Firmware DVD</p> <ul style="list-style-type: none"> ▪ Firmware is already installed on the controllers. ▪ The files on the DVD are backup copies. <p>SANtricity ES Storage Manager Installation DVD</p> <ul style="list-style-type: none"> ▪ SANtricity ES Storage Manager software and documentation. ▪ To access product documentation, use the documentation map file, <code>doc_launcher.html</code>, which is located in the <code>docs</code> directory. | ✓ |

Tools and Other Items

Tools and Other Items

| | Item | Included with the Tray |
|--|---|------------------------|
| | Labels Help you to identify cable connections and lets you more easily trace cables from one tray to another | |
| | A cart Holds the tray and components | |
| | A mechanical lift (optional) | |
|  | A Phillips screwdriver | |
|  | A flat-blade screwdriver | |
|  | Anti-static protection | |
| | A flashlight | |
| <p>Use the Compatibility Matrix, at the following website, to obtain the latest hardware compatibility information. http://www.lsi.com/compatibilitymatrix/</p> | | |

Things to Know – SFP Transceivers, Fiber-Optic Cables, Copper Cables, and SAS Cables

The figures in this topic display the fiber-optic cables, copper cables, SFP transceivers., and SAS cables with a SFF-8088 Connector.



NOTE Your SFP transceivers and cables might look slightly different from the ones shown. The differences do not affect the performance of the SFP transceivers.

The controller-drive tray supports SAS, Fibre Channel (FC), and iSCSI host connections and SAS drive connections. FC host connections can operate at 8 Gb/s or at a lower data rate. Ports for 8-Gb/s Fibre Channel host connections require SFP transceivers designed for this data rate. These SFP transceivers look similar to other SFP transceivers but are not compatible with other types of connections. SFP transceivers for 1-Gb/s iSCSI and 10-Gb/s iSCSI connections have a different physical interface for the cable and are not compatible with other types of connections.



WARNING (W03) Risk of exposure to laser radiation – Do not disassemble or remove any part of a Small Form-factor Pluggable (SFP) transceiver because you might be exposed to laser radiation.

Fiber-Optic Cable Connection

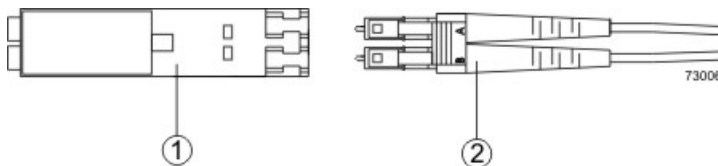

1. Active SFP Transceiver
2. Fiber-Optic Cable

1-Gb/s iSCSI Cable Connection

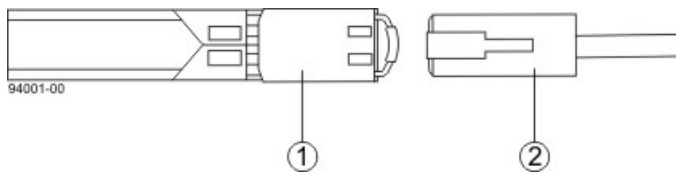

1. Active SFP Transceiver
2. Copper Cable with RJ-45 Connector

Copper Fibre Channel Cable Connection

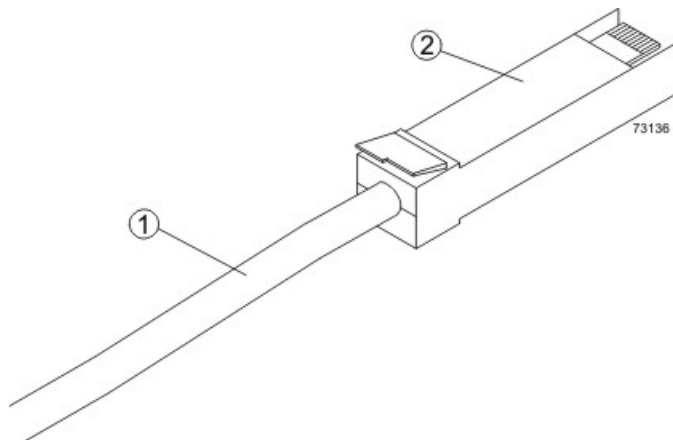

1. Copper Fibre Channel Cable
2. Passive SFP Transceiver

SAS Cable Connection

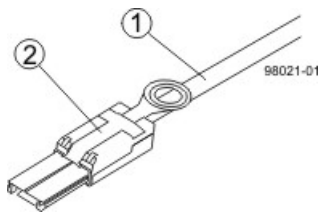

1. SAS Cable
2. SFF-8088 Connector

Things to Know – Taking a Quick Glance at the Hardware in a CDE2600 Controller-Drive Tray Configuration



WARNING (W14) Risk of bodily injury – A qualified service person is required to make the DC power connection according to NEC and CEC guidelines.



CAUTION (C05) Electrical grounding hazard – This equipment is designed to permit the connection of the DC supply circuit to the earthing conductor at the equipment.



IMPORTANT Each tray in the storage array must have a minimum of two drives for proper operation. If the tray has fewer than two drives, a power supply error is reported.

- The top of the controller-drive tray is the side with labels.
- The configuration of the host ports might appear different on your system depending on which host interface card configuration is installed.

CDE2600 Controller-Drive Tray with 12 Drives – Front View

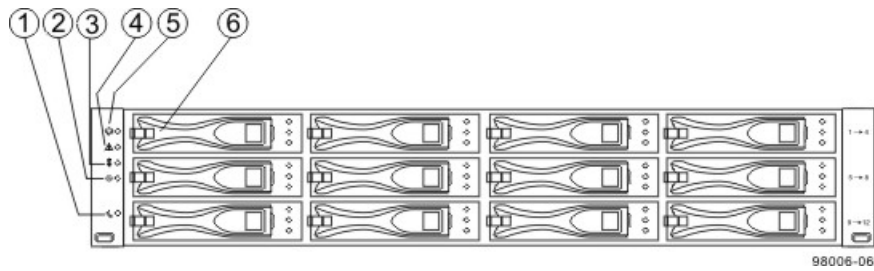

1. End Cap Standby Power LED
2. End Cap Power LED
3. End Cap Over-Temperature LED
4. End Cap Service Action Required LED
5. End Cap Locate LED
6. Drive Canister

CDE2600 Controller-Drive Tray with 24 Drives – Front View

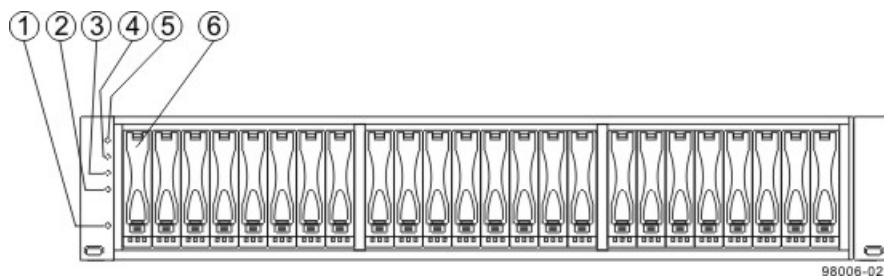

1. End Cap Standby Power LED
2. End Cap Power LED
3. End Cap Over-Temperature LED
4. End Cap Service Action Required LED
5. End Cap Locate LED
6. Drive Canister

CDE2600 Controller-Drive Tray Duplex Configuration– Rear View

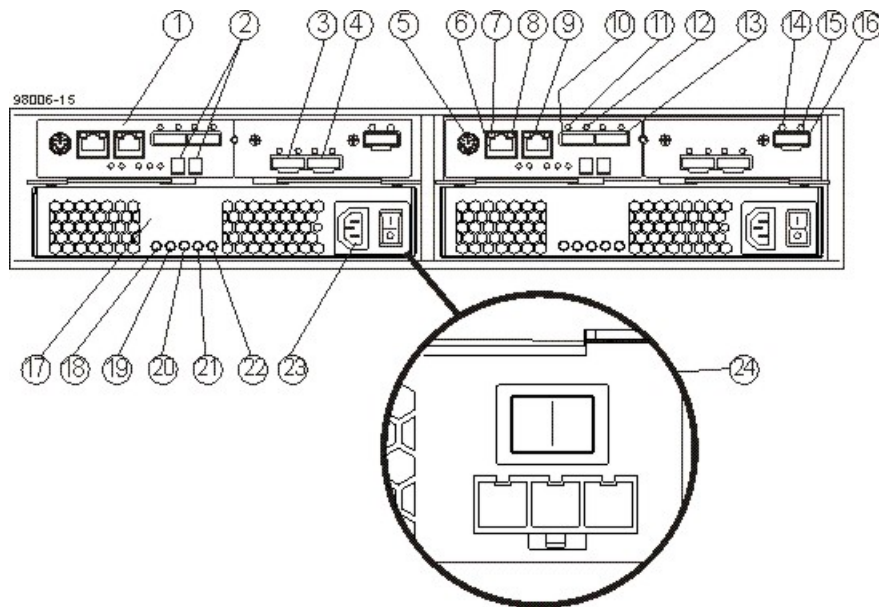

1. Controller A Canister
2. Seven-Segment Display
3. Host Interface Card Connector 1
4. Host Interface Card Connector 2
5. Serial Connector
6. Ethernet Connector 1
7. Ethernet Link Active LED
8. Ethernet Link Rate LED
9. Ethernet Connector 2
10. Host SFF-8088 Connector 2 (Native)
11. Host Link 2 Fault LED
12. Host Link 2 Active LED
13. Base Host SFF-8088 Connector 1
14. ESM Expansion Fault LED
15. ESM Expansion Active LED
16. Expansion SFF-8088 Port Connector
17. Power-Fan Canister
18. Standby Power LED
19. Power-Fan DC Power LED
20. Power-Fan Service Action Allowed LED
21. Power-Fan Service Action Required LED
22. Power-Fan AC Power Connector and Switch
23. Power-Fan DC Power Connector and Switch

CDE2600 Right-Rear Subplate with No Host Interface Card



98019-04

1. ESM Expansion Fault LED
2. ESM Expansion Active LED
3. Expansion SFF-8088 Port Connector

CDE2600 Right-Rear Subplate with a SAS Host Interface Card

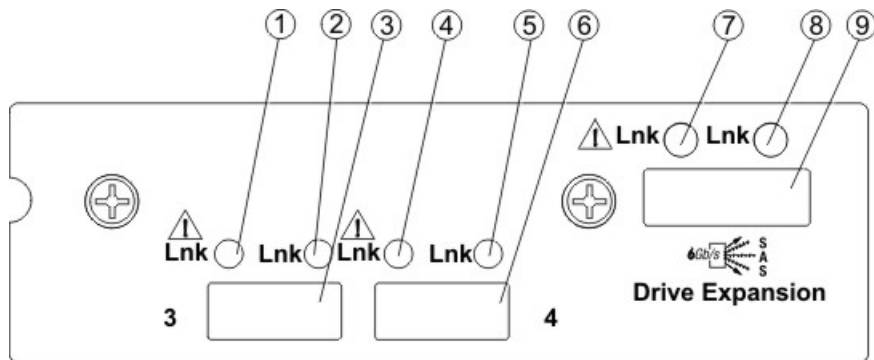

98019-03

1. Host Interface Card Link 3 Up LED
2. Host Interface Card Link 3 Active LED
3. SFF-8088 Host Interface Card Connector 3
4. Host Interface Card Link 4 Up LED
5. Host Interface Card Link 4 Active LED
6. SFF-8088 Host Interface Card Connector 4
7. ESM Expansion Fault LED
8. ESM Expansion Active LED
9. Expansion SFF-8088 Port Connector

CDE2600 Right-Rear Subplate with an FC Host Interface Card

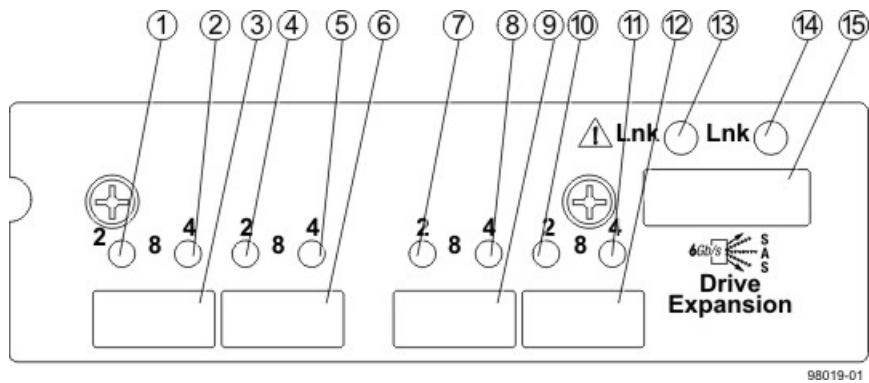

1. Host Interface Card Link 3 Up LED
2. Host Interface Card Link 3 Active LED
3. FC Host Interface Card Connector 3
4. Host Interface Card Link 4 Up LED
5. Host Interface Card Link 4 Active LED
6. FC Host Interface Card Connector 4
7. Host Interface Card Link 5 Up LED
8. Host Interface Card Link 5 Active LED
9. FC Host Interface Card Connector 5
10. Host Interface Card Link 6 Up LED
11. Host Interface Card Link 6 Active LED
12. FC Host Interface Card Connector 6
13. ESM Expansion Fault LED
14. ESM Expansion Active LED
15. Expansion SFF-8088 Port Connector

CDE2600 Right-Rear Subplate with a 1-Gb iSCSI Host Interface Card

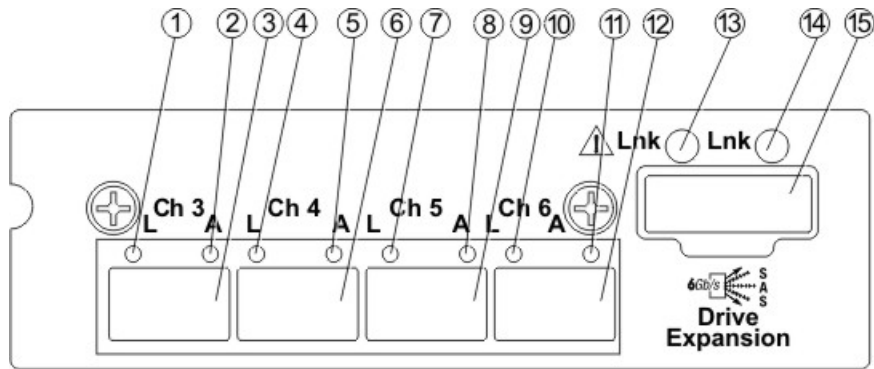

98019-02

1. Host Interface Card Link 3 Up LED
2. Host Interface Card Link 3 Active LED
3. iSCSI Host Interface Card Connector 3
4. Host Interface Card Link 4 Up LED
5. Host Interface Card Link 4 Active LED
6. iSCSI Host Interface Card Connector 4
7. Host Interface Card Link 5 Up LED
8. Host Interface Card Link 5 Active LED
9. iSCSI Host Interface Card Connector 5
10. Host Interface Card Link 6 Up LED
11. Host Interface Card Link 6 Active LED
12. iSCSI Host Interface Card Connector 6
13. ESM Expansion Fault LED
14. ESM Expansion Active LED
15. Expansion SFF-8088 Port Connector

CDE2600 Right-Rear Subplate with a 10-Gb iSCSI Host Interface Card

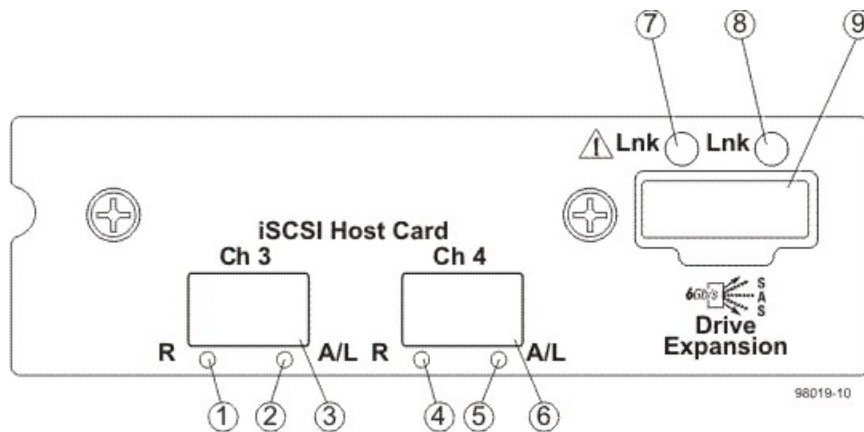

1. Host Interface Card Link 3 Up LED
2. Host Interface Card Link 3 Active LED
3. iSCSI Host Interface Card Connector 3
4. Host Interface Card Link 4 Up LED
5. Host Interface Card Link 4 Active LED
6. iSCSI Host Interface Card Connector 4
7. ESM Expansion Fault LED
8. ESM Expansion Active LED
9. Expansion SFF-8088 Port Connector

CDE2600 Controller-Drive Tray Simplex Configuration – Rear View

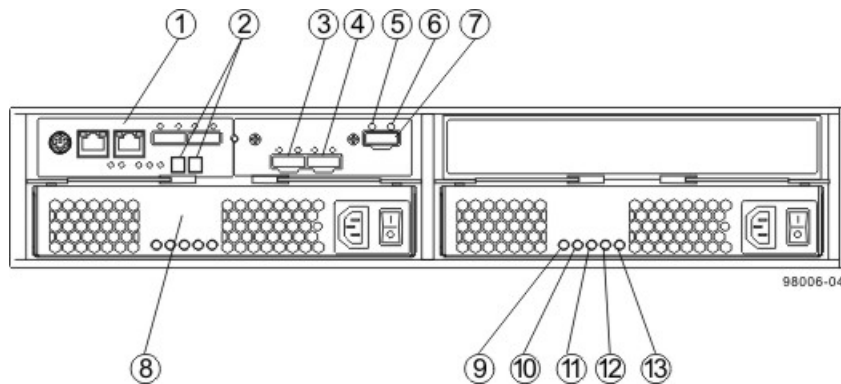

1. Controller A Canister
2. Seven-Segment Display
3. Host Interface Card Connector 1
4. Host Interface Card Connector 2
5. ESM Expansion Fault LED
6. ESM Expansion Active LED
7. Expansion Port SFF-8088 Connector
8. Power-Fan A Canister (optional)
9. Standby Power LED
10. Power-Fan DC Power LED
11. Power-Fan Service Action Allowed LED
12. Power-Fan Service Action Required LED
13. Power-Fan AC Power LED

⚠ ATTENTION Possible equipment damage – You must use the supported drives in the drive tray to ensure proper performance. For information about supported drives, contact a Customer and Technical Support representative.

⚠ ATTENTION Risk of equipment malfunction – To avoid exceeding the functional and environmental limits, install only drives that have been provided or approved by the original manufacturer. Not all controller-drive trays are shipped with pre-populated drives. System integrators, resellers, system administrators, or users of the controller-drive tray can install the drives.

DE1600 Drive Tray – Front View

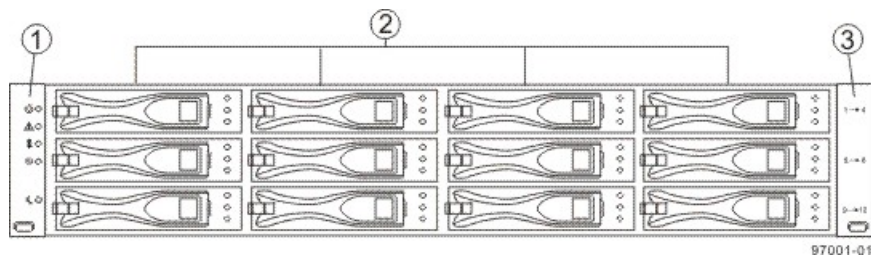

1. Left End Cap (Has the Drive Tray LEDs)
2. Drives
3. Right End Cap

DE5600 Drive Tray – Front View

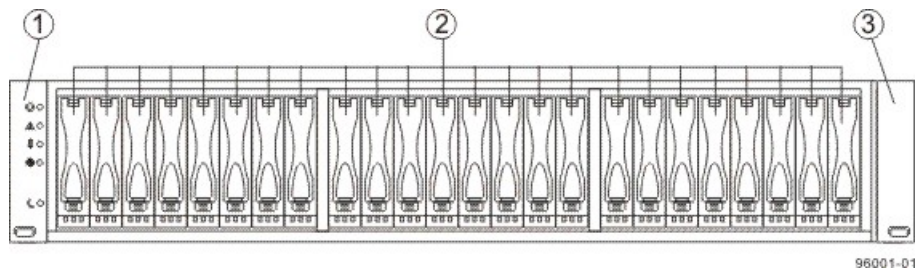

1. Left End Cap (Has the Drive Tray LEDs)
2. Drives
3. Right End Cap

DE1600 Drive Tray or DE5600 Drive Tray with AC Power Option – Rear View

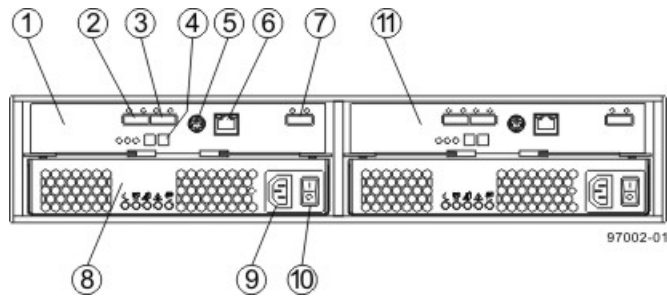

1. ESM A Canister
2. Host Connector 1
3. Host Connector 2
4. Seven-Segment Display Indicators
5. Serial Connector
6. Ethernet Connector
7. Expansion Port SFF-8088 Connector
8. Power-Fan Canister
9. Power Connector
10. Power Switch
11. ESM B Canister

DE1600 Drive Tray or DE5600 Drive Tray with DC Power Option – Rear View

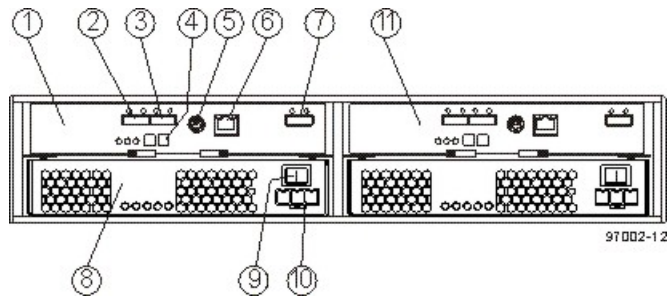

1. ESM A Canister
2. Host Connector 1
3. Host Connector 2
4. Seven-Segment Display Indicators
5. Serial Connector
6. Ethernet Connector
7. Expansion Port SFF-8088 Connector
8. Power-Fan Canister
9. Power Connector
10. Power Switch
11. ESM B Canister

You can order an optional DC power supply connection and connector cables for the drive tray. **A qualified service person is required to make the DC power connection per NEC and CEC guidelines.** A two-pole 30-amp circuit breaker is required between the DC power source and the drive tray for over-current and short-circuit protection. Before turning off any power switches on a DC-powered drive tray, you must disconnect the two-pole 30-amp circuit breaker.



WARNING (W12) Risk of electrical shock – This unit has more than one power source. To remove all power from the unit, all DC MAINS must be disconnected by removing all power connectors (item 4 below) from the power supplies.

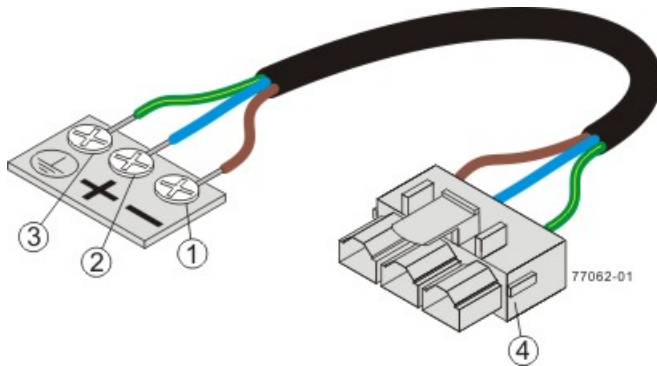

1. Supply (Negative), Brown Wire, -48 VDC
2. Return (Positive), Blue Wire
3. Ground, Green/Yellow Wire
4. DC Power Connector

For Additional Information on the CDE2600 Controller-Drive Tray Configuration

Refer to the *Storage System Site Preparation Guide* on the SANtricity ES Storage Manager Installation DVD for information about the installation requirements of the various CDE2600 storage array components.

Step 2 – Installing and Configuring the Switches

Things to Know – Switches



IMPORTANT Most of the switches, as shipped from the vendor, require an update to their firmware to work correctly with the storage array.

Depending on the configuration of your storage array, you might use Fibre Channel switches and iSCSI switches.

The switches in the following table are certified for use with a CDE2600 storage array, a CDE2600-60 storage array, a CDE4900 storage array, and a CE7900 storage array, which all use SANtricity ES Storage Manager Version 10.77.

Supported Switches

| Vendor | Model | Fibre Channel | iSCSI | SAS |
|---------|-------|---------------|-------|-----|
| Brocade | 200E | Yes | No | No |
| | 3200 | Yes | No | No |
| | 3800 | Yes | No | No |
| | 3900 | Yes | No | No |
| | 3950 | Yes | No | No |
| | 12000 | Yes | No | No |
| | 3850 | Yes | No | No |
| | 3250 | Yes | No | No |
| | 24000 | Yes | No | No |
| | 4100 | Yes | No | No |
| | 48000 | Yes | No | No |
| | 5000 | Yes | No | No |
| | 300 | Yes | No | No |
| | 5100 | Yes | No | No |
| | 5300 | Yes | No | No |
| | 7500 | Yes | No | No |
| | 7800 | Yes | No | No |
| DCX | Yes | No | No | |

| Vendor | Model | Fibre Channel | iSCSI | SAS |
|--------|---------------------|---------------|-------|-----|
| | FCOE | No | Yes | No |
| Cisco | 9506 | Yes | No | No |
| | 9509 | Yes | No | No |
| | 9216 | Yes | No | No |
| | 9216i | Yes | No | No |
| | 9120 | Yes | No | No |
| | 914x | Yes | No | No |
| | 9513 | Yes | No | No |
| | 9020 | Yes | No | No |
| | MDS9000 | Yes | No | No |
| | 9222i | Yes | No | No |
| | 9134 | Yes | No | No |
| | Catalyst 2960 | No | Yes | No |
| | Catalyst 3560 | No | Yes | No |
| | Catalyst 3750G-24TS | No | Yes | No |
| LSI | 6160 | No | No | Yes |
| McData | 3232 | Yes | No | No |
| | 3216 | Yes | No | No |
| | 4300 | Yes | No | No |
| | 4500 | Yes | No | No |
| | 6064 | Yes | No | No |
| | 6140 | Yes | No | No |
| | 4400 | Yes | No | No |
| | 4700 | Yes | No | No |
| QLogic | 6140 | No | Yes | No |
| | 6142 | No | Yes | No |
| | SANbox2-8 | Yes | No | No |

| Vendor | Model | Fibre Channel | iSCSI | SAS |
|--------------|------------|---------------|-------|-----|
| | SANbox2-16 | Yes | No | No |
| | SANbox5200 | Yes | No | No |
| | SANbox3600 | Yes | No | No |
| | SANbox3800 | Yes | No | No |
| | SANbox5208 | Yes | No | No |
| | SANbox5600 | Yes | No | No |
| | SANbox5800 | Yes | No | No |
| | SANbox9000 | Yes | No | No |
| PowerConnect | 5324 | No | Yes | No |
| | 6024 | No | Yes | No |

If required, make the appropriate configuration changes for *each* switch that is connected to the storage array.

Refer to the switch's documentation for information about how to install the switch and how to use the configuration utilities that are supplied with the switch.

Procedure – Installing and Configuring Switches

1. Install your switch according to the vendor's documentation.
2. Use the Compatibility Matrix at the website <http://www.lsi.com/compatibilitymatrix/> to obtain this information:
 - The latest hardware compatibility information
 - The models of the switches that are supported
 - The firmware requirements and the software requirements for the switches
3. Update the switch's firmware by accessing it from the applicable switch vendor's website.

This update might require that you cycle power to the switch.

4. Find your switch in the following table to see whether you need to make further configuration changes. Use your switch's configuration utility to make the changes.

Supported Switch Vendors and Required Configuration Changes

| Switch Vendor | Configuration Changes Required? | Next Step |
|---------------|---|---|
| Brocade | Yes Change the In-Order Delivery (IOD) option to ON. | Make the change, and go to "Step 3 – Installing the Host Bus Adapters for the CDE2600 Controller-Drive Tray." |

| Switch Vendor | Configuration Changes Required? | Next Step |
|---------------|---|---|
| Cisco | Yes Change the In-Order Delivery (IOD) option to ON. | Make the change, and go to “Step 3 – Installing the Host Bus Adapters for the CDE2600 Controller-Drive Tray.” |
| LSI | No | “Step 3 – Installing the Host Bus Adapters for the CDE2600 Controller-Drive Tray.” |
| McData | No | “Step 3 – Installing the Host Bus Adapters for the CDE2600 Controller-Drive Tray.” |
| QLogic | No | “Step 3 – Installing the Host Bus Adapters for the CDE2600 Controller-Drive Tray.” |
| PowerConnect | No | “Step 3 – Installing the Host Bus Adapters for the CDE2600 Controller-Drive Tray.” |

Step 3 – Installing the Host Bus Adapters for the CDE2600 Controller-Drive Tray

Key Terms

HBA host port

The physical and electrical interface on the host bus adapter (HBA) that provides for the connection between the host and the controller. Most HBAs will have either one or two host ports. The HBA has a unique World Wide Identifier (WWID) and each HBA host port has a unique WWID.

HBA host port world wide name

A 16-character unique name that is provided for each port on the host bus adapter (HBA).

host bus adapter (HBA)

A physical board that resides in the host. The HBA provides for data transfer between the host and the controllers in the storage array over the I/O host interface. Each HBA contains one or more physical ports.

Things to Know – Host Bus Adapters and Ethernet Network Interface Cards

- The CDE2600 controller-drive tray supports dual 6-Gb/s SAS host connections and optional host interface cards (HICs) for dual 6-Gb/s SAS, four 1-Gb/s iSCSI, two 10-Gb iSCSI, and four 8-Gb/s FC connections. The connections on a host must match the type (SAS HBAs for SAS, FC HBAs for FC, or iSCSI HBAs or Ethernet network interface cards [NICs] for iSCSI) of the HICs to which you connect them. For the best performance, HBAs for SAS and FC connections should support the highest data rate supported by the HICs to which they connect.
- For maximum hardware redundancy, you must install a minimum of two HBAs (for either SAS or FC host connections) or two NICs or iSCSI HBAs (for iSCSI host connections) in each host. Using both ports of a dual-port HBA or a dual-port NIC provides two paths to the storage array but does not ensure redundancy if an HBA or a NIC fails.



NOTE You can use the Compatibility Matrix to obtain information about the supported models of the HBAs and their requirements. Go to <http://www.lsi.com/compatibilitymatrix/>, and select the desired Developer Partner Program link. Check its Compatibility Matrix to make sure you have an acceptable configuration.

- Most of the HBAs, as shipped from the vendor, require updated firmware and software drivers to work correctly with the storage array. For information about the updates, refer to the website of the HBA vendor.

Procedure – Installing Host Bus Adapters

1. Go to <http://www.lsi.com/compatibilitymatrix/>, and select the desired Developer Partner Program link. Check its Compatibility Matrix to make sure you have an acceptable configuration.

The Compatibility Matrix provides this information:

- The latest hardware compatibility information
- The models of the HBAs that are supported
- The firmware requirements and the software requirements for the HBAs

2. Install your HBA according to the vendor documentation.



NOTE If your operating system is Windows Server 2008 Server Core, you might have additional installation requirements. Refer to the Microsoft Developers Network (MSDN) for more information about Windows Server 2008 Server Core. You can access these resources from www.microsoft.com.

3. Install the latest version of the firmware for the HBA. You can find the latest version of the firmware for the HBA at the HBA vendor website.



NOTE The remaining steps are general steps to obtain the HBA host port world wide name from the HBA BIOS utility. If you have installed the host context agent on all of your hosts, you do not need to perform these steps. If you are performing these steps, the actual prompts and screens vary depending on the vendor that provides the HBA. Also, some HBAs have software utilities that you can use to obtain the world wide name for the port instead of using the BIOS utility.

4. Reboot or start your host.
5. While your host is booting, look for the prompt to access the HBA BIOS utility.
6. Select each HBA to view its HBA host port world wide name.
7. Record the following information for each host and for each HBA connected to the storage array:
 - The name of each host
 - The HBAs in each host
 - The HBA host port world wide name of each port on the HBA

The following table shows examples of the host and HBA information that you must record.

Examples of HBA Host Port World Wide Names

| Host Name | Associated HBAs | HBA Host Port World Wide Name |
|----------------|---------------------------------|--|
| ICTENGINEERING | Vendor x, Model y (dual port) | 37:38:39:30:31:32:33:32 37:38:39:30:31:32:33:33 |
| | Vendor a, Model y (dual port) | 42:38:39:30:31:32:33:42 42:38:39:30:31:32:33:44 |
| ICTFINANCE | Vendor a, Model b (single port) | 57:38:39:30:31:32:33:52 |
| | Vendor x, Model b (single port) | 57:38:39:30:31:32:33:53 |

Step 4 – Installing the CDE2600 Controller-Drive Tray

Things to Know – General Installation

The power supplies meet standard voltage requirements for both domestic and worldwide operation.

 **NOTE** Make sure that the combined power requirements of your trays do not exceed the power capacity of your cabinet.

Procedure – Installing the CDE2600 Controller-Drive Tray

Airflow Direction Through and Clearance Requirements for the CDE2600 Controller-Drive Tray with 12 Drives

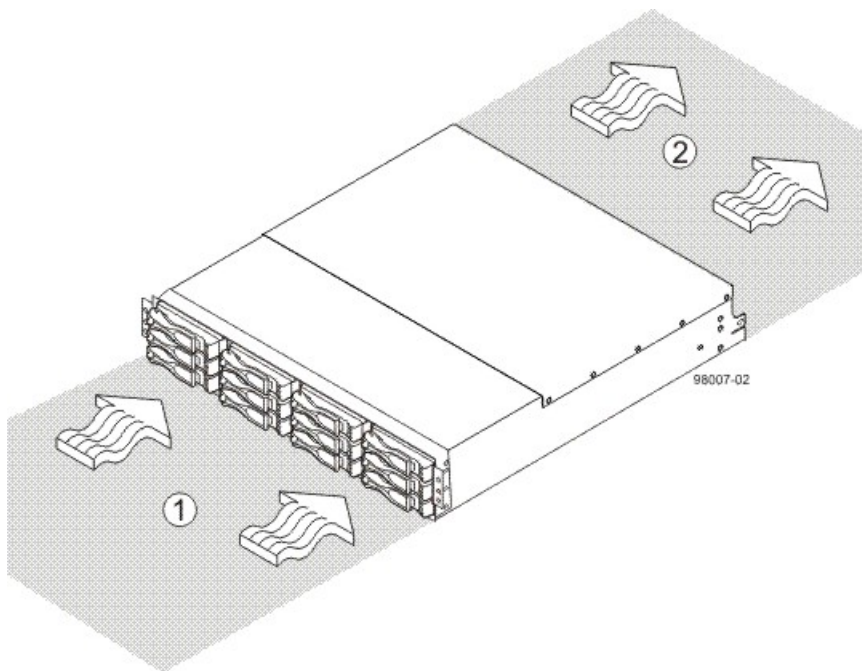

1. 76-cm (30-in.) clearance in front of the cabinet
2. 61-cm (24-in.) clearance behind the cabinet

Airflow Direction Through and Clearance Requirements for the CDE2600 Controller-Drive Tray with 24 Drives

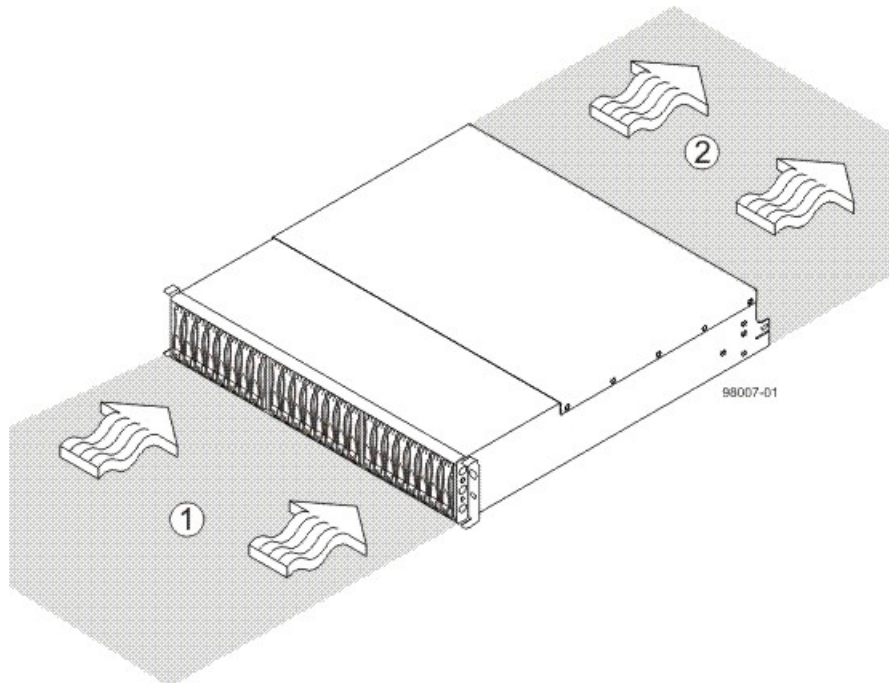

1. 76-cm (30-in.) clearance in front of the cabinet
2. 61-cm (24-in.) clearance behind the cabinet



WARNING (W08) Risk of bodily injury –



>18 kg (39.7 lbs)

Two persons are required to safely lift the component.

1. Make sure that the cabinet is in the final location. Make sure that the cabinet installation site meets the clearance requirements (see the previous two figures for "Airflow Direction Through and Clearance Requirements for the CDE2600 Controller-Drive Tray with 12 Drives" and "Airflow Direction Through and Clearance Requirements for the CDE2600 Controller-Drive Tray with 24 Drives").
2. Lower the feet on the cabinet, if required, to keep it from moving.
3. Install the mounting rails in the cabinet. For more information, refer to the installation instructions that are included with your mounting rails.
 - If you are installing the mounting rails above an existing tray, position the mounting rails directly above the existing tray.
 - If you are installing the mounting rails below an existing tray, allow 17.8-cm (7.00-in.) clearance below the existing tray.

⚠ ATTENTION Risk of equipment malfunction – To avoid exceeding the functional and environmental limits, install only drives that have been provided or approved by the original manufacturer. Not all controller-drive trays are shipped with pre-populated drives. System integrators, resellers, system administrators, or users of the controller-drive tray can install the drives.

📌 NOTE Make sure that you place the controller-drive tray in the middle portion of the cabinet while allowing room for drive trays to be placed above and below the controller-drive tray. As you add drive trays, position them below and above the controller-drive tray, alternating so that the cabinet does not become top heavy.

4. With the help of one other person, slide the rear of the controller-drive tray onto the mounting rails. Make sure that the top mounting holes on the controller-drive tray align with the mounting rail holes of the cabinet (see the following two figures for "Securing the CDE2600 Controller-Drive Tray with 12 Drives to the Cabinet" and "Securing the CDE2600 Controller-Drive Tray with 24 Drives to the Cabinet").

The rear of the controller-drive tray slides into the slots on the mounting rails.

Securing the CDE2600 Controller-Drive Tray with 12 Drives to the Cabinet

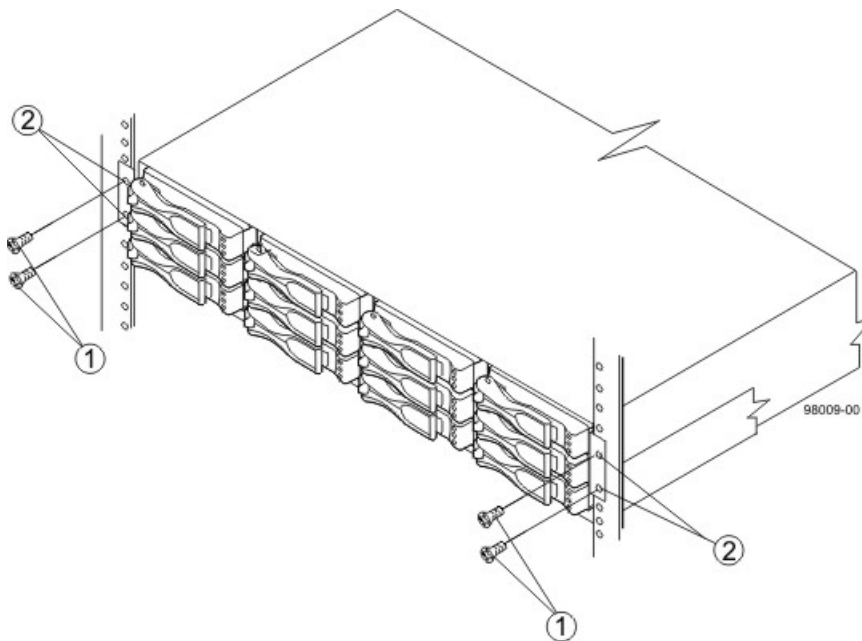

1. Screws
2. Mounting Holes

Securing the CDE2600 Controller-Drive Tray with 24 Drives to the Cabinet

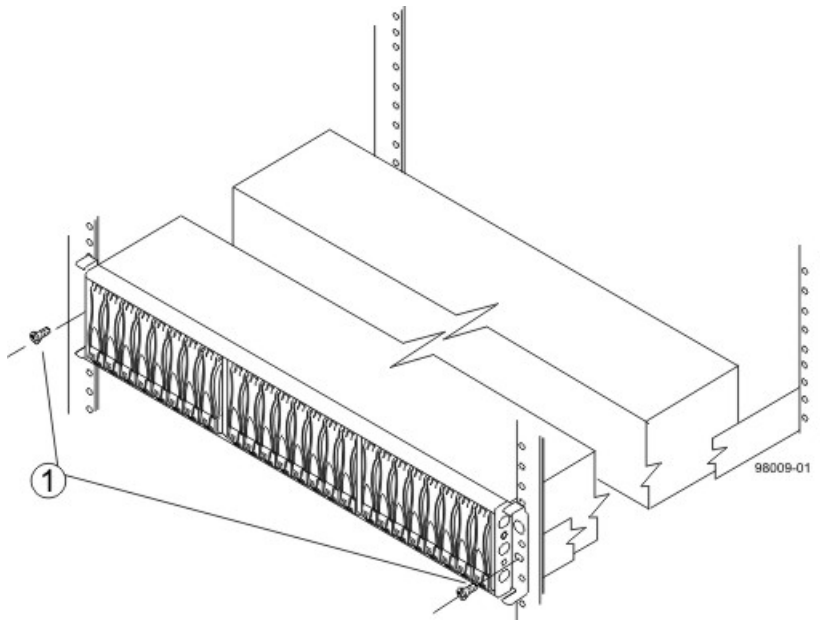

1. Screws



NOTE The rear of the controller-drive tray contains two controllers. The top of the controller-drive tray is the side with the labels.

5. Secure the screws in the top mounting holes and the bottom mounting holes on each side of the controller-drive tray.
6. Secure the rear of the of the controller-drive tray to the cabinet by using two screws to attach the flanges on each side at the rear of the controller-drive tray to the mounting rails.
7. Install the bezel on the front of the controller-drive tray.
8. Install the drive trays. Refer to [Step 7 – Connecting the CDE2600 Controller-Drive Tray to the Drive Trays](#).

Step 5 – Connecting the CDE2600 Controller-Drive Tray to the Hosts

Key Terms

direct topology

A topology that does not use a switch.

switch topology

A topology that uses a switch.

topology

The logical layout of the components of a computer system or network and their interconnections. Topology deals with questions of what components are directly connected to other components from the standpoint of being able to communicate. It does not deal with questions of physical location of components or interconnecting cables. (The Dictionary of Storage Networking Terminology)

Things to Know – Host Channels



ATTENTION Possible hardware damage – To prevent electrostatic discharge damage to the tray, use proper antistatic protection when you handle tray components.

- Each controller has from two to six host ports.
- Two of the host ports are standard and support 6-Gb/s SAS data rates.
- Two to four of the host ports are optional, and, if present, are located on a host interface card (HIC). The following types of HICs are supported:



NOTE In configurations where a HIC does not exist, the space is covered with a blank faceplate.

- Two SAS connectors at 6-Gb/s
- Four iSCSI connectors at 1-Gb/s
- Two iSCSI connectors at 10-Gb/s
- Four FC connectors at 8-Gb/s

Host Channels on the Controllers – Rear View

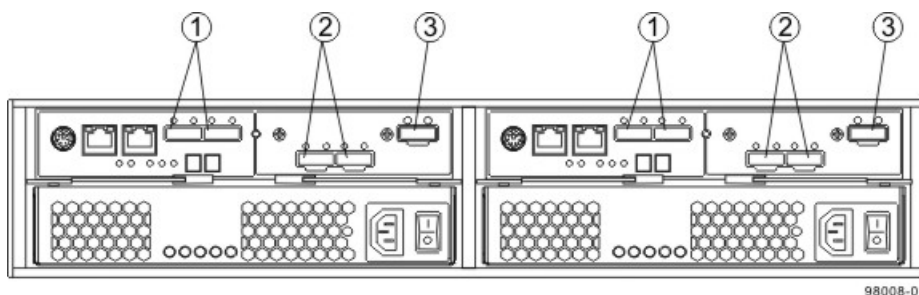

1. Standard Host Connectors
2. Host Interface Card (HIC) Connectors (SAS in this Example)
3. SAS Expansion Connector

WARNING (W03) Risk of exposure to laser radiation – Do not disassemble or remove any part of a Small Form-factor Pluggable (SFP) transceiver because you might be exposed to laser radiation.

Procedure – Connecting Host Cables on a CDE2600 Controller-Drive Tray

IMPORTANT Make sure that you have installed the HBAs. Refer to the documentation for the HBAs for information about how to install the HBA and how to use the supplied configuration utilities.

The type of HICs (SAS, FC, or iSCSI) must match the type of the host bus adapters (HBAs) or network interface cards (for iSCSI only) to which you connect them.

See the examples in the following section for example cabling patterns.

1. Perform one of these actions:
 - **You are using an FC HIC** – Go to [step 2](#).
 - **You are using either a SAS or an iSCSI HIC** – Go to [step 4](#). Connections for both SAS and iSCSI use copper cables with RJ-45 connectors and do not require SFP transceivers.
2. Make sure that the appropriate type of SFP transceiver is inserted into the host channel.
3. If a black, plastic plug is in the SFP transceiver, remove it.
4. Perform one of these actions:
 - **You are using either a SAS or an iSCSI HIC** – Starting with the first host channel of each controller, plug one end of the cable into the host channel.
 - **You are using an FC HIC** – Starting with the first host channel of each controller, plug one end of the cable into the SFP transceiver in the host channel.

The cable is either an Ethernet cable with RJ-45 connectors for 1-Gb/s iSCSI or 6-Gb/s SAS connections, or a fiber-optic cable for FC connections.

IMPORTANT If Remote Volume Mirroring connections are required, do not connect a host to the highest numbered host channel.

Direct Topology – One Host Connected to a Single Controller

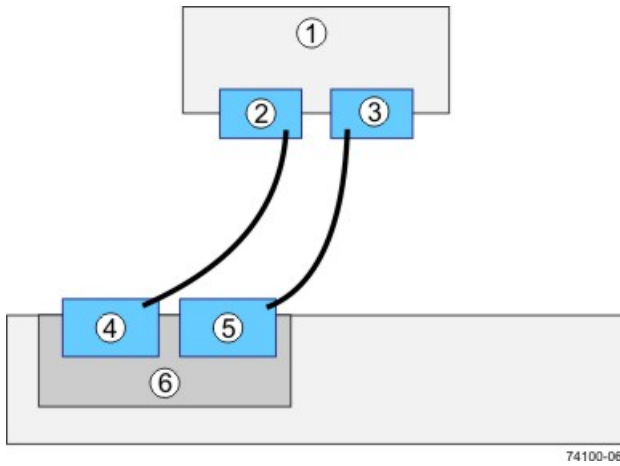

1. Host
2. HBA 1 or NIC 1
3. HBA 2 or NIC 2
4. Host Port 1
5. Host Port 2
6. Controller A

Direct Topology – Two Hosts Connected to a Single Controller

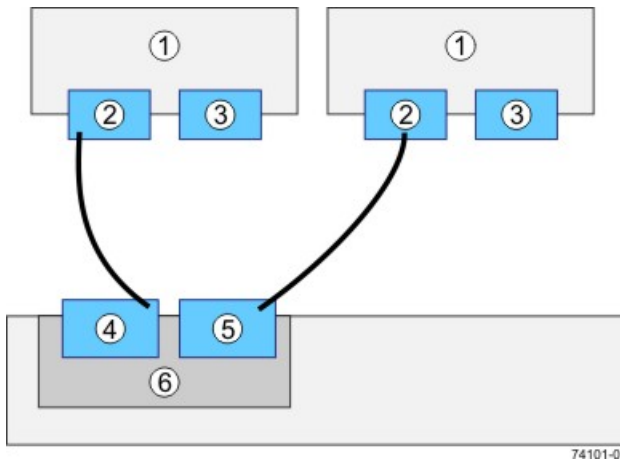

1. Host
2. HBA 1 or NIC 1
3. HBA 2 or NIC 2
4. Host Port 1
5. Host Port 2
6. Controller A

Switch Topology – Two Hosts Connected to a Single Controller Through a Switch

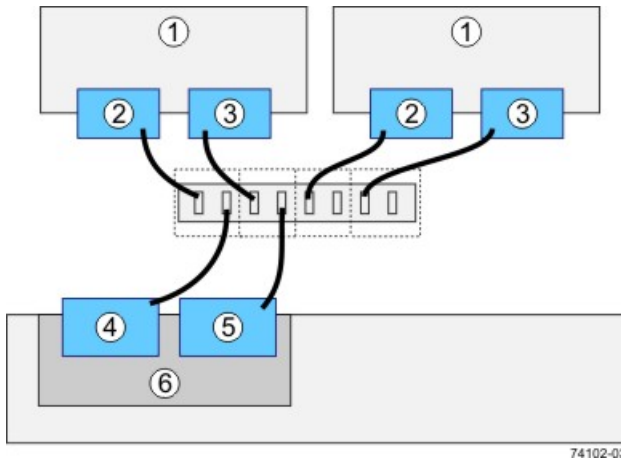

1. Host
2. HBA 1 or NIC 1
3. HBA 2 or NIC 2
4. Host Port 1
5. Host Port 2
6. Controller A

Direct Topology – One Host and a Dual Controller-Drive Tray

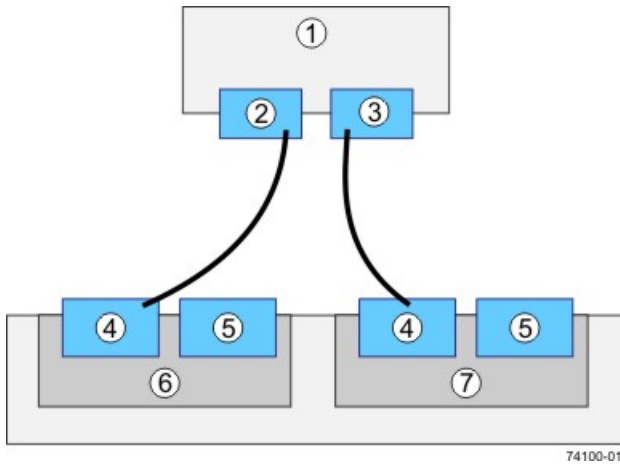

1. Host
2. HBA 1 or NIC 1
3. HBA 2 or NIC 2
4. Host Port 1
5. Host Port 2
6. Controller A
7. Controller B

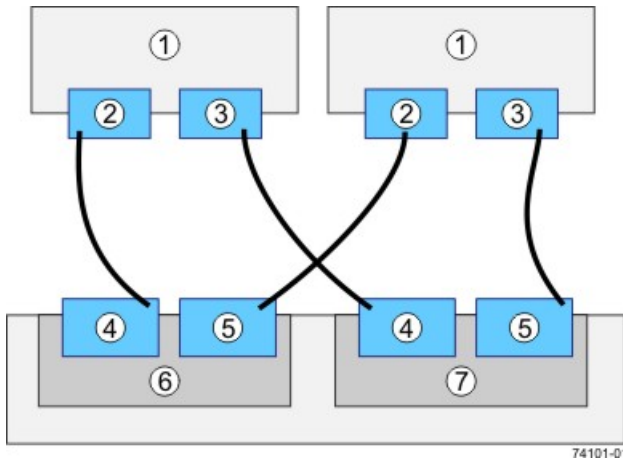
Direct Topology – Two Hosts and a Dual Controller-Drive Tray for Maximum Redundancy

1. Hosts
2. HBA 1 or NIC 1
3. HBA 2 or NIC 2
4. Host Port 1
5. Host Port 2
6. Controller A
7. Controller B

Mixed Topology – Two Hosts and a Dual Controller-Drive Tray

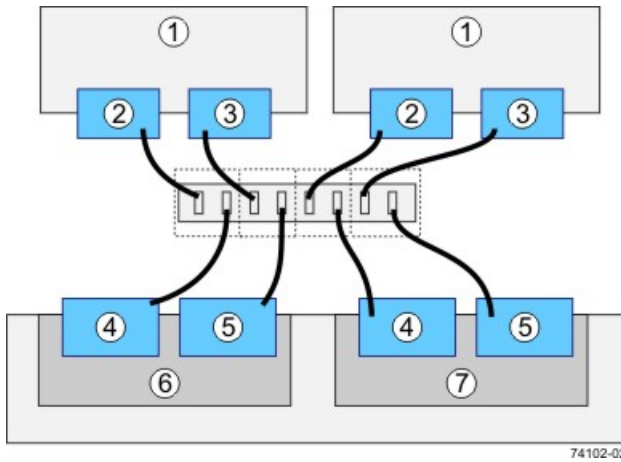

1. Hosts
2. HBA 1 or NIC 1
3. HBA 2 or NIC 2
4. Host Port 1
5. Host Port 2
6. Controller A
7. Controller B

Mixed Topology – Three Hosts and a Dual Controller-Drive Tray

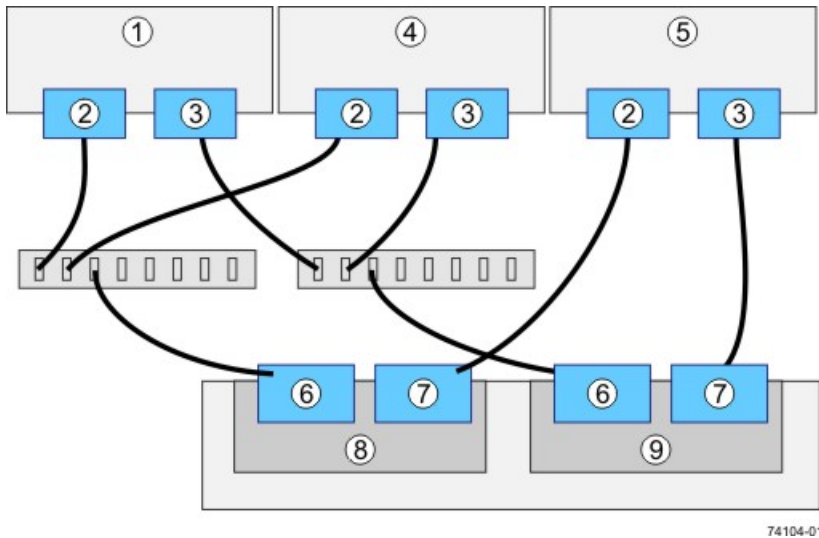

74104-01

1. Host 1
2. HBA 1 or NIC 1
3. HBA 2 or NIC 2
4. Host 2
5. Host 3
6. Host Port 1
7. Host Port 2
8. Controller A
9. Controller B

5. Plug the other end of the cable either into an HBA in the host (direct topology) or into a switch (fabric topology).



NOTE The SAS host interface does not support a switch topology.

6. Affix a label to each end of the cable with this information. A label is very important if you need to disconnect cables to service a controller. Include this information on the labels:
 - The host name and the HBA port (for direct topology)
 - The switch name and the port (for fabric topology)
 - The controller ID (for example, controller A)
 - The host channel ID (for example, host channel 1)

Example label abbreviation – Assume that a cable is connected between port 1 in HBA 1 of a host named Engineering and host channel 1 of controller A. A label abbreviation could be as follows.

Heng-HBA1/P1, CtA-Hch1

7. Repeat step 3 through step 6 for each controller and host channel that you intend to use.

Step 6 – Installing the Drive Trays for the CDE2600 Controller-Drive Tray Configurations

Things to Know – General Installation of Drive Trays with the CDE2600 Controller-Drive Tray

 **IMPORTANT** If you are installing the drive tray in a cabinet with other trays, make sure that the combined power requirements of the drive tray and the other trays do not exceed the power capacity of your cabinet. For more information, refer to the SANtricity ES Storage Manager Installation DVD.

- Special site preparation is not required for any of these drive trays beyond what is normally found in a computer lab environment.
 - The power supplies meet standard voltage requirements for both domestic and worldwide operation.
 - Take these precautions:
 - Install the drive trays in locations within the cabinet that let you evenly distribute the drive trays around the controller-drive tray.
 - Keep as much weight as possible in the bottom half of the cabinet.
-

 **WARNING (W15) Risk of bodily injury** – An empty tray weighs approximately 56.7 kg (125 lb). Three persons are required to safely move an empty tray. If the tray is populated with components, a mechanized lift is required to safely move the tray.

For Additional Information on Drive Tray Installation

Refer to the *Storage System Site Preparation Guide* on the SANtricity ES Storage Manager Installation DVD for important considerations about cabinet installation.

Procedure – Installing the DE1600 Drive Trays and the DE5600 Drive Trays

 **WARNING (W08) Risk of bodily injury** –



>18 kg (39.7 lbs)

Two persons are required to safely lift the component.

 **WARNING (W05) Risk of bodily injury** – If the bottom half of the cabinet is empty, do not install components in the top half of the cabinet. If the top half of the cabinet is too heavy for the bottom half, the cabinet might fall and cause bodily injury. Always install a component in the lowest available position in the cabinet.

You can install the drive tray into an industry standard cabinet.

This procedure describes how to install the mounting rails into an industry standard cabinet.

⚠ ATTENTION Possible hardware damage – To prevent electrostatic discharge damage to the tray, use proper antistatic protection when handling tray components.

1. Make sure that the cabinet is in the final location. Make sure that you meet the clearance requirements shown in the following two figures.

DE1600 Drive Tray Airflow and Clearance Requirements

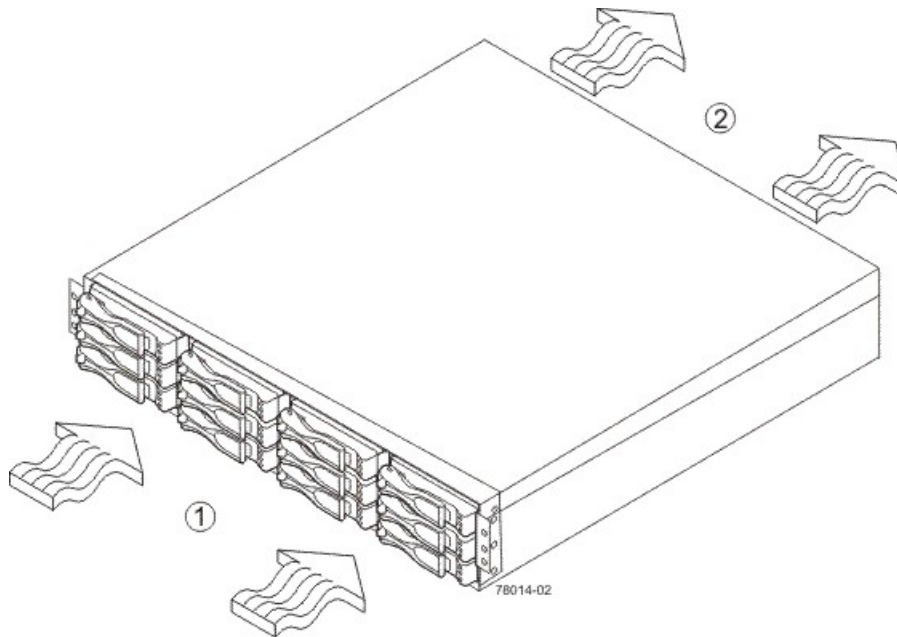

1. 76 cm (30 in.) clearance in front of the cabinet
2. 61 cm (24 in.) clearance behind the cabinet

DE5600 Drive Tray Airflow and Clearance Requirements

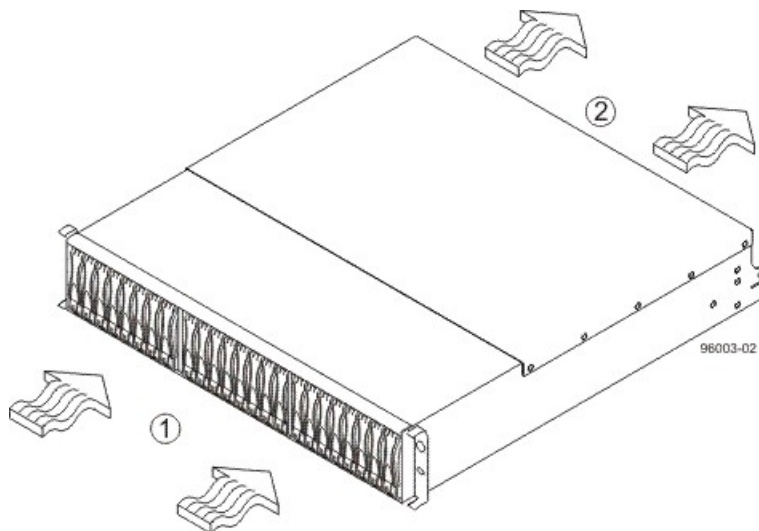

1. 76 cm (30 in.) clearance in front of the cabinet
2. 61 cm (24 in.) clearance behind the cabinet



NOTE Fans pull air through the tray from front to back across the drives.

2. Lower the feet on the cabinet to keep the cabinet from moving.
3. Remove the drive tray and all contents from the shipping carton.
4. Position the mounting rails in the cabinet.

Positioning the Mounting Rails in the Cabinet

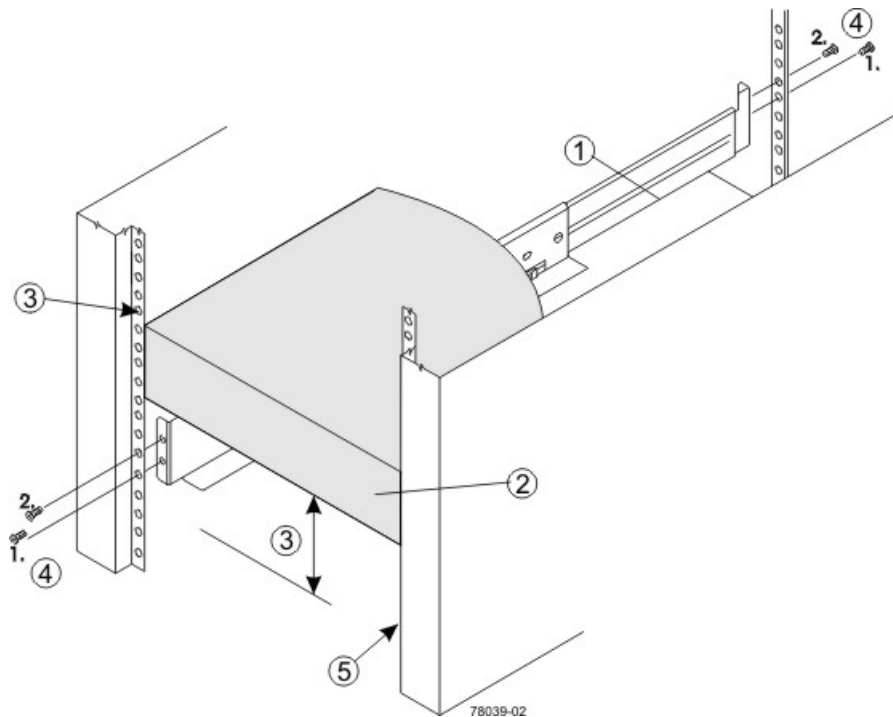

1. Mounting Rail
2. Existing Tray
3. Clearance Above and Below the Existing Tray
4. Screws for Securing the Mounting Rail to the Cabinet (Front and Rear)
5. Industry Standard Cabinet

- If you are installing the mounting rails above an existing tray, position the mounting rails directly above the tray.
 - If you are installing the mounting rails below an existing tray, allow 8.8-cm (3.5-in.) vertical clearance for the drive tray.
5. Attach the mounting rails to the cabinet by performing these substeps:
 - a. Make sure that the adjustment screws on the mounting rail are loose so that the mounting rail can extend or contract as needed.

Attaching the Mounting Rails to the Cabinet

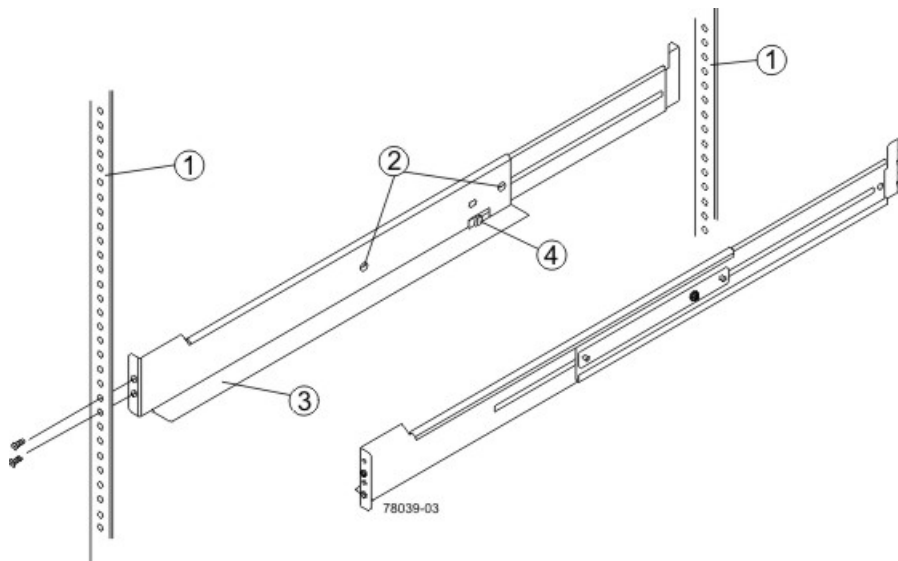

1. Cabinet Mounting Holes
 2. Adjustment Screws for Locking the Mounting Rail Length
 3. Mounting Rails
 4. Clip for Securing the Rear of the Drive Tray
- b. Place the mounting rail inside the cabinet, and extend the mounting rail until the flanges on the mounting rail touch the inside of the cabinet.
- c. Make sure that the alignment spacers on the front flange of the mounting rail fit into the mounting holes in the cabinet.

The front flange of each mounting rail has two alignment spacers. The alignment spacers are designed to fit into the mounting holes in the cabinet. The alignment spacers help position and hold the mounting rail.

Alignment Spacers on the Mounting Rail

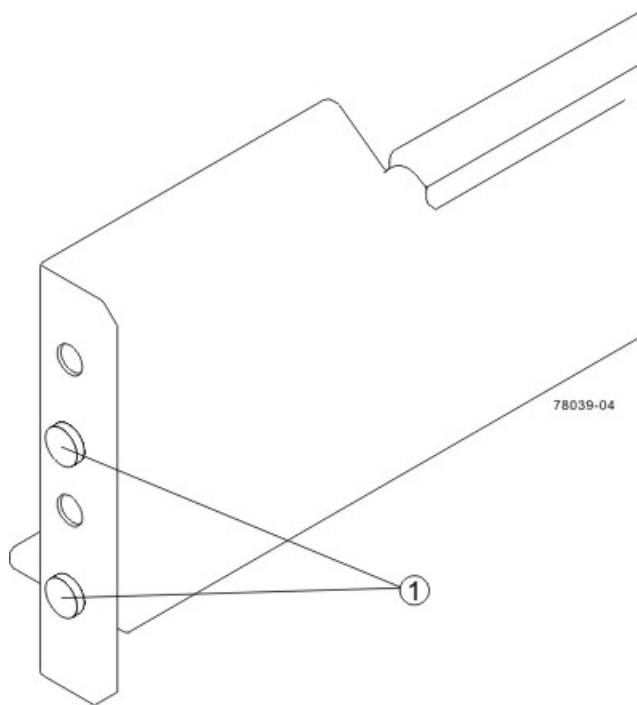

1. Alignment Spacers
 - d. Insert one M5 screw through the front of the cabinet and into the top captured nut in the mounting rail. Tighten the screw.
 - e. Insert two M5 screws through the rear of the cabinet and into the captured nuts in the rear flange in the mounting rail. Tighten the screws.
 - f. Tighten the adjustment screws on the mounting rail.
 - g. Repeat substep a through substep f to install the second mounting rail.
6. With the help of one other person, slide the rear of the drive tray onto the mounting rails. The rear edge of the drive tray must fit into the clip on the mounting rail. The drive tray is correctly aligned when these conditions are met:
 - The mounting holes on the front flanges of the drive tray align with the mounting holes on the front of the mounting rails.
 - The rear edge of the drive tray sheet metal fits into the clip on the mounting rail.
 - The holes in the drive tray sheet metal for the rear hold-down screws align with the captured nuts in the side of the mounting rails.

Sliding the Drive Tray into the Clip on the Mounting Rail

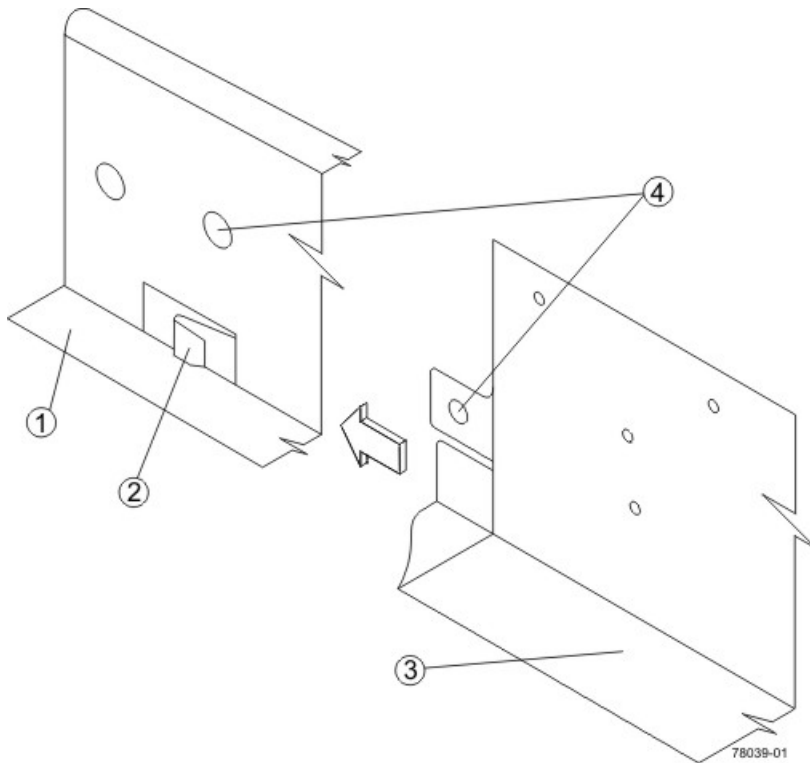

1. Mounting Rail
 2. Clip
 3. Partial View of the Drive Tray Rear Sheet Metal
 4. Align the hole in the drive tray sheet metal with the captured nut in the mounting rail.
7. Secure the front of the drive tray to the cabinet. Use the two screws to attach the flange on each side of the front of the drive tray to the mounting rails.
- a. Insert one M5 screw through the bottom hole of a flange on the drive tray so that the screw goes through the cabinet rail and engages the bottom captured nut in the mounting rail. Tighten the screw.
 - b. Repeat substep a for the second flange.

Attaching the Front of the DE1600 Drive Tray

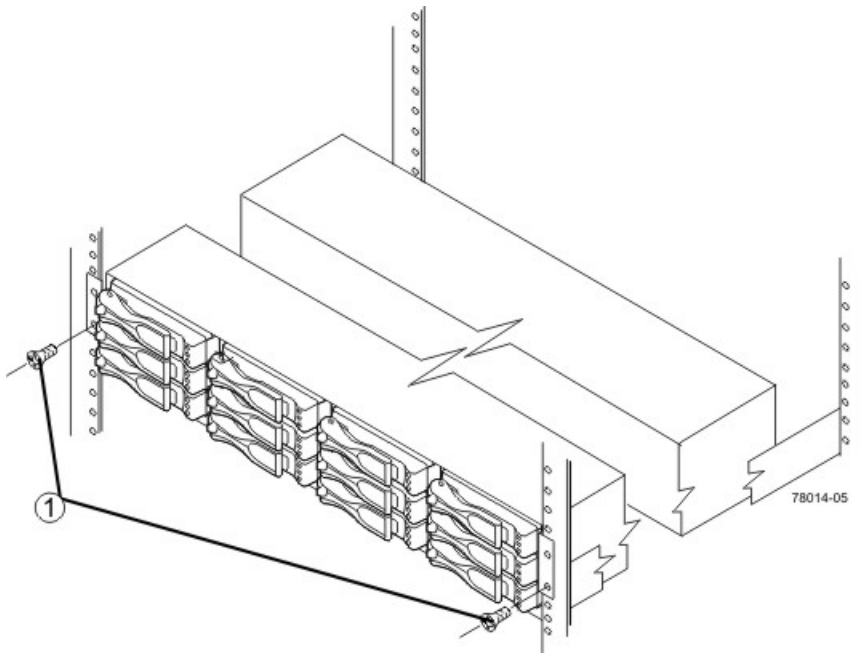

1. Screws for Securing the Front of the Drive Tray

Attaching the Front of the DE1600 Drive Tray

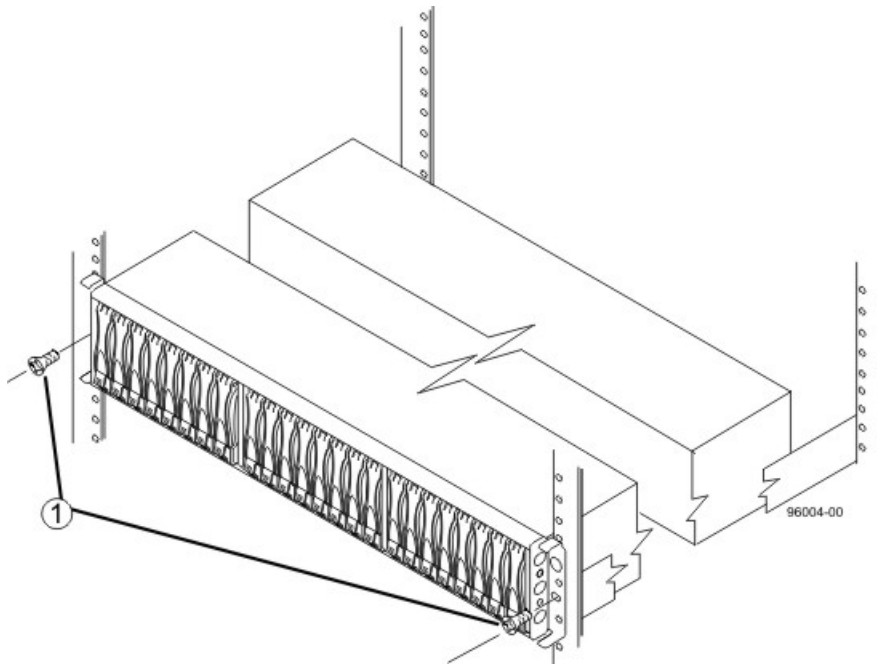

1. Screws for Securing the Front of the Drive Tray
8. Secure the side of the drive tray to the mounting rails by performing these substeps:
 - a. Insert one M4 screw through the side sheet metal of the DE1600 drive tray into the captured nut on the side of the mounting rail. Tighten the screw.
 - b. Repeat substep a for the other side.
9. Attach the plastic end caps onto the front of the drive tray.
 - a. Put the top of the end cap on the hinge tab that is part of the drive tray mounting flange.
 - b. Gently press on the bottom of the end cap until it snaps into place over the retainer on the bottom of the drive tray mounting flange.

Attaching the End Caps to the DE1600 Drive Tray

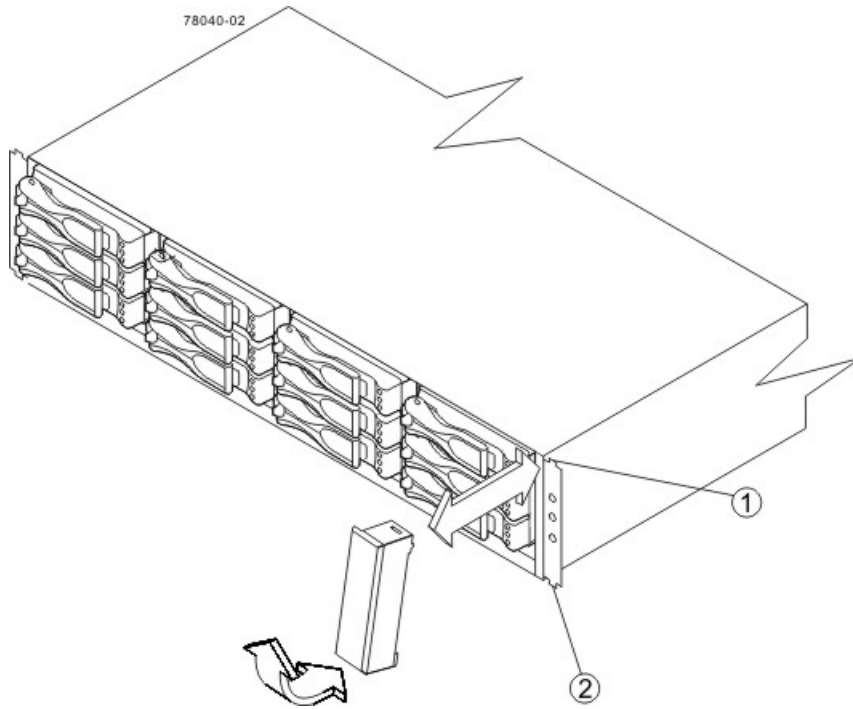

- 1. Hinge Tab
- 2. Retainer

Attaching the End Caps to the DE5600 Drive Tray

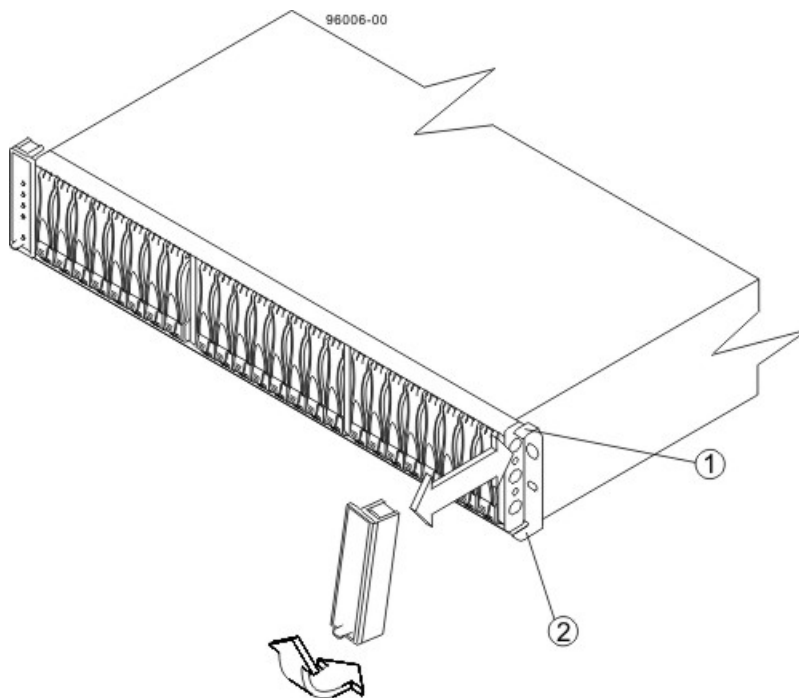

1. Hinge Tab
2. Retainer

Procedure – Installing Drives in the DE1600 Drive Trays and the DE5600 Drive Trays

In some situations, the drive tray might be delivered without the drives installed. Follow the steps in this procedure to install the drives. If your drive tray already has drives installed, you can skip this step and go to either [Things to Know – AC Power Cords](#) or [Things to Know – DC Power Cords](#).

⚠ ATTENTION Risk of equipment malfunction – To avoid exceeding the functional and environmental limits, install only drives that have been provided or approved by the original manufacturer. Drives might be shipped but not installed. System integrators, resellers, system administrators, or users can install the drives.

📌 NOTE The installation order is from top to bottom and from left to right. The installation order is important because the drives might already contain configuration information that depends upon the correct sequence of the drives in the tray.

1. Beginning with the first drive slot in the upper-left side of the drive tray, place the drive on the slot guides, and slide the drive all the way into the slot.

2. Push the drive handle to the right (DE1600 drive tray) or down (DE5600 drive tray) to lock the drive securely in place.

Installing a Drive in the DE1600 Drive Tray

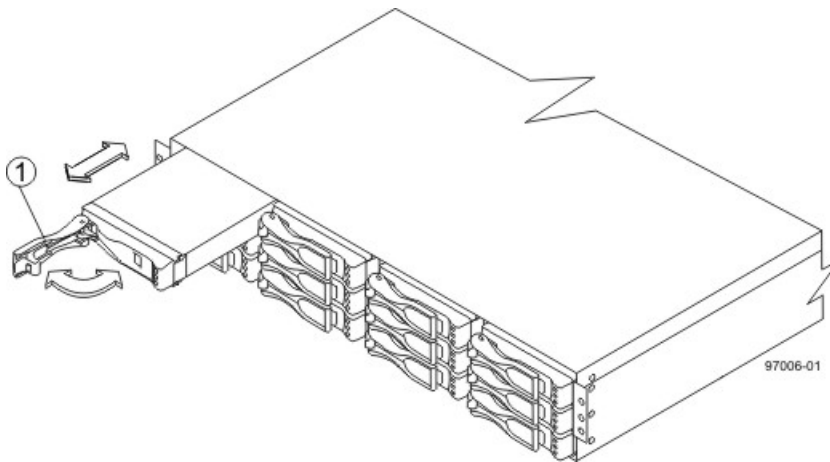

1. Drive Handle

Installing a Drive in the DE5600 Drive Tray

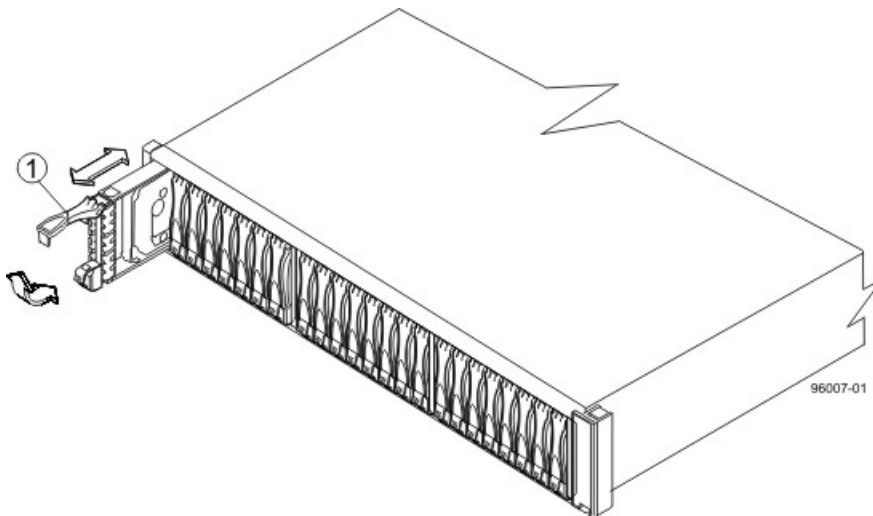

1. Drive Handle



NOTE In some applications, the drive handle might have the hinge on the right.

3. Install the second drive beneath the first drive (DE1600 drive tray) or to the right of the first drive (DE5600 drive tray).
4. Install the other drives from top to bottom and then from left to right (DE1600 drive tray) or to the right (DE5600 drive tray).

Step 7 – Connecting the CDE2600 Controller-Drive Tray to the Drive Trays

Key Terms

drive channel

The path for the transfer of data between the controllers and the drives in the storage array.

Things to Know – CDE2600 Controller-Drive Tray



NOTE On the CDE2600 controller-drive tray, each controller has a pair of levers with handles for removing the controller from the controller-drive tray. One of these handles on each controller is located next to a host connector. The close spacing between the handle and the host connector might make it difficult to remove a cable that is attached to the host connector. If this problem occurs, use a flat-blade screwdriver to push in the release component on the cable connector.

- The CDE2600 controller-drive tray supports both the DE1600 drive tray and the DE5600 drive tray for expansion.
- The maximum number of drive slots in the storage array is 96 (expandable to 192, including the 12 or 24 drive slots in the controller-drive tray). Exceeding 96 (or 192) drive slots makes the storage array invalid. The controllers cannot perform operations that modify the configuration, such as creating new volumes.
- Each controller has one dual-ported SAS expansion connector to connect to the drive trays.

Drive Channel Ports on the CDE2600 Controller-Drive Tray – Rear View

1. Controller Canister
2. SAS Expansion Connector



IMPORTANT To maintain data access in the event of the failure of a controller, an ESM, or a drive channel, you must connect a drive tray or a string of drive trays to both drive channels on a redundant path pair.

Things to Know – Drive Trays with the CDE2600 Controller-Drive Tray

- Each DE1600 drive tray can contain a maximum of twelve 8.89-cm (3.5-in.) drives.
- Each DE5600 drive tray can contain a maximum of twenty-four 6.35-cm (2.5-in.) drives.
- The ESMs on the DE1600 drive tray and the DE5600 drive tray contain two sets of In connectors and one set of Out connectors.

DE1600 Drive Tray and DE5600 Drive Tray – Rear View

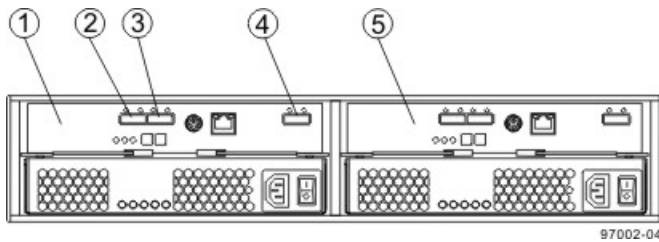

1. ESM A
2. SAS Connector 1 (In)
3. SAS Connector 2 (In)
4. Expansion Connector (Out)
5. ESM B

Things to Know – Drive Tray Cabling Configurations – Simplex System

The following figure shows an example of cable configurations from the simplex CDE2600 controller-drive tray to either a DE1600 drive tray or a DE5600 drive tray. Use this example as a guide to connect cables in your storage array.



IMPORTANT Configurations for connecting cables in a simplex system do not provide for tray loss protection. Loss of a drive tray that has a second drive tray connected to it means that you cannot access the second drive tray.

Controller-Drive Tray Above the Drive Tray

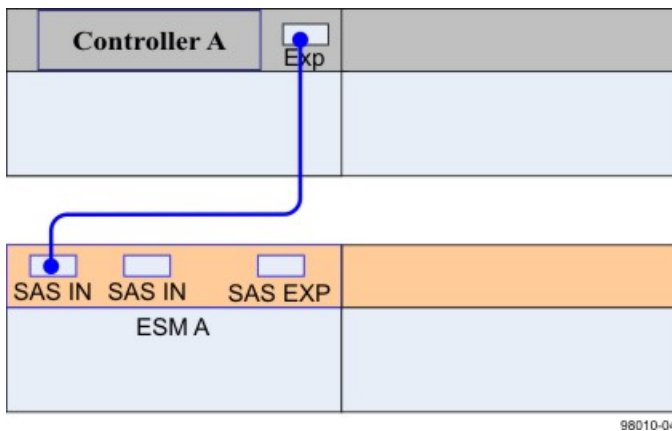

Things to Know – Drive Tray Cabling Configurations – Duplex System

The figures in this topic show examples of cable configurations from the controller-drive tray to the drive trays. Use these examples as guides to connect cables in your storage array.

IMPORTANT The configuration shown in the fourth image in this topic provides an example of tray loss protection. With tray loss protection, if one drive tray cannot be accessed, you still have access to the remaining drive trays.

Controller-Drive Tray Above the Drive Tray

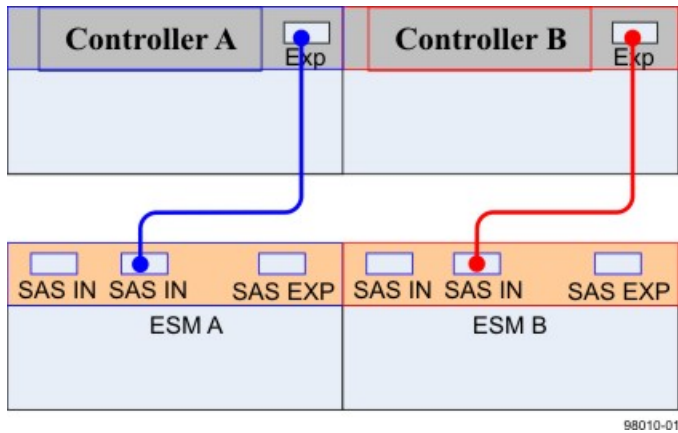

98010-01

Controller-Drive Tray Between Two Drive Trays

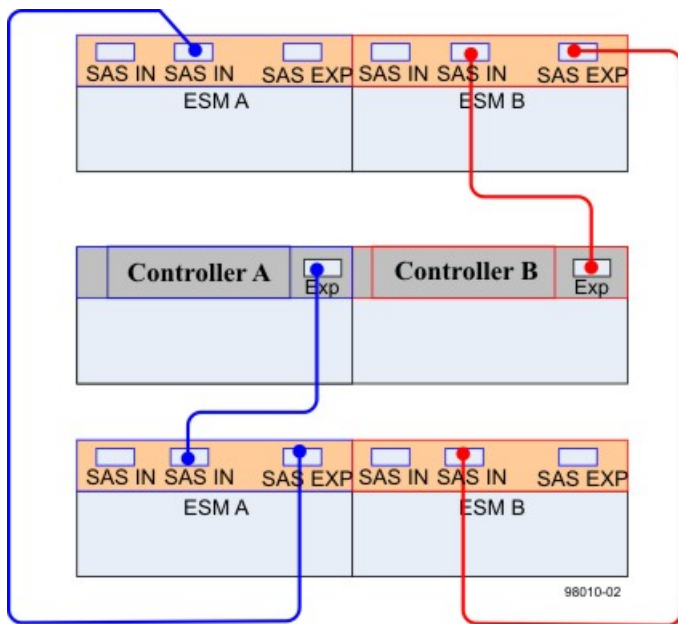

98010-02

Controller-Drive Tray with Three Drive Trays

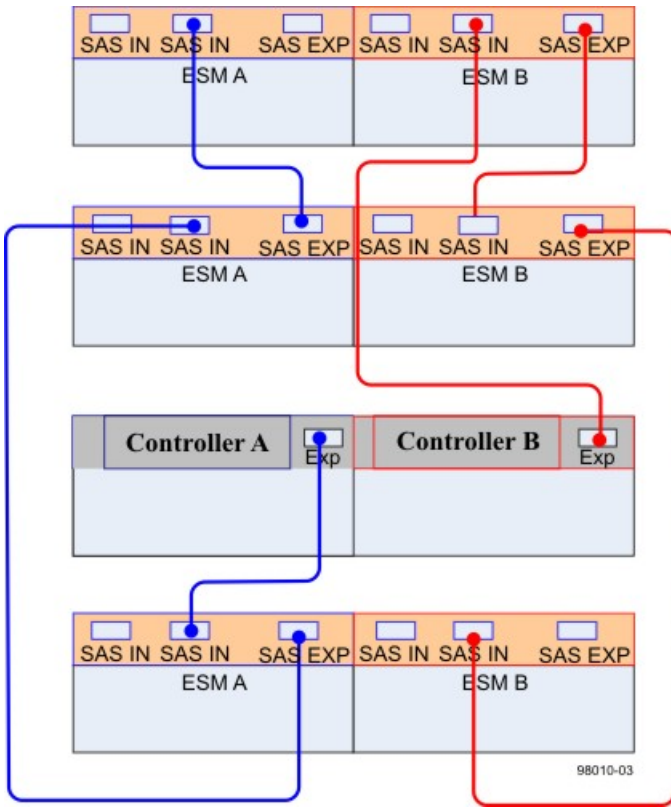

Connecting Cables for Maximum Redundancy and Tray Loss Protection

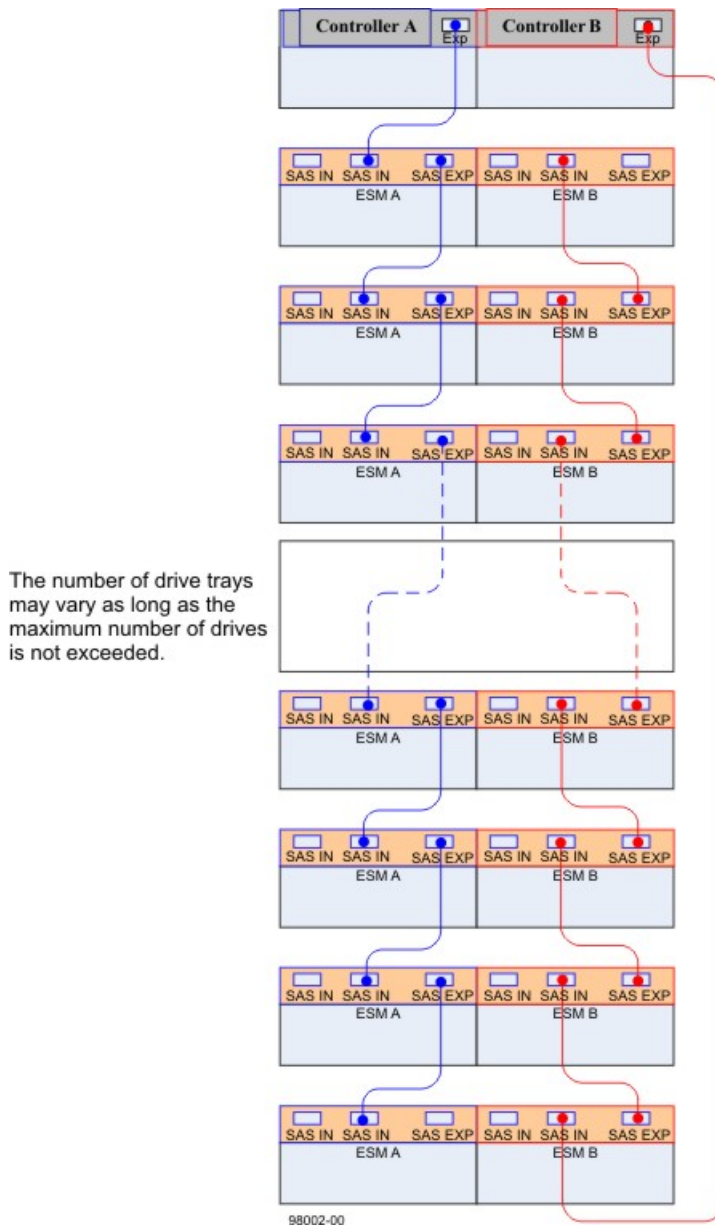

Procedure – Connecting the DE1600 Drive Trays and the DE5600 Drive Trays

1. Use the following table to determine the number of SAS cables that you need.

Drive Tray Cables

| Number of Drive Trays that You Plan to Connect to the Controller-Drive Tray | Number of Cables Required |
|---|---------------------------|
| 1 | 2 |
| 2 | 4 |
| 3 | 6 |

2. If there is a black, plastic plug in the SAS expansion connector of the controller, remove it.
3. Insert one end of the cable into the SAS expansion connector on the controller in slot A in the controller-drive tray.
4. Insert the other end of the cable into the connector with an up arrow on the ESM in slot A in the drive tray.
5. Are you adding more drive trays?



IMPORTANT Each ESM in a drive tray has three expansion connectors: two on the left-center of the ESM and one in the upper-right side. When connecting from an ESM in one drive tray to an ESM in another drive tray, make sure that you connect the connector on the upper-right to one of the connectors on the left-center. The following figure shows these arrows on an ESM. If the cable is connected either between the two left-center ESM connectors or between two upper-right ESM connectors, communication between the two drive trays is lost.



NOTE It does not matter which of the two left-center ESM connectors you use to connect to the expansion connector on the far-right side.

Connecting a Cable from One ESM to a Second ESM

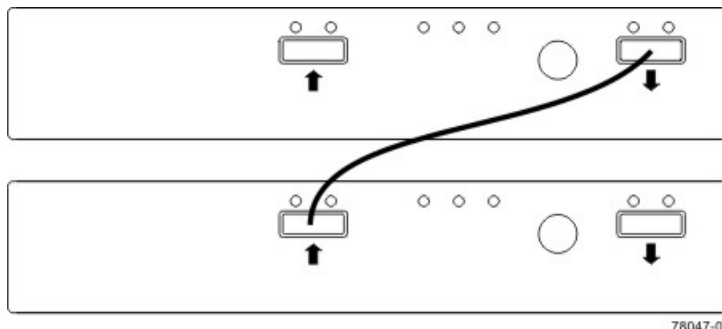

- **Yes** – Go to step 6.
 - **No** – Go to step 9.
6. In the ESM in the first drive tray, insert one end of the cable into the connector on the far-right side.
 7. In the ESM in the next drive tray, insert the other end of the cable into one of the connectors in the left-center of the ESM.
 8. Repeat step 6 through step 7 for each drive tray that you intend to add to the storage array.

9. To each end of the cables, attach a label with this information:

- The controller ID (for example, controller A)
- The ESM ID (for example, ESM A)
- The ESM connector (In or Out)
- The drive tray ID

For example, if you are connecting controller A to the In connector on ESM A in drive tray 1, the label on the controller end of the cable will have this information:

```
CtA-Dch1, Dm1-ESM_A (left), In - Controller End
```

The label on the drive tray end of the cable will have this information:

```
Dm1-ESM_A (left), In, CtrlA
```

10. If you are installing the controller-drive tray with two controllers, repeat step 2 through step 9 for the controller in slot B in the controller-drive tray.



IMPORTANT To connect cables for maximum redundancy, the cables attaching controller B must be connected to the drive trays in the opposite tray order as for controller A. That is, the last drive tray in the chain from controller A must be the first drive tray in the chain from controller B.

Step 8 – Connecting the Ethernet Cables

Key Terms

in-band management

A method to manage a storage array in which a storage management station sends commands to the storage array through the host input/output (I/O) connection to the controller.

out-of-band management

A method to manage a storage array in which a storage management station sends commands to the storage array through the Ethernet connections on the controller.

Things to Know – Connecting Ethernet Cables



ATTENTION Risk of security breach – Connect the Ethernet ports on the controller tray to a private network segment behind a firewall. If the Ethernet connection is not protected by a firewall, your storage array might be at risk of being accessed from outside of your network.

- These Ethernet connections are intended for out-of-band management and have nothing to do with the iSCSI host interface cards (HICs), whether 1Gb/s or 10Gb/s.
- Ethernet port 2 on each controller is reserved for access by your Customer and Technical Support representative.
- In limited situations in which the storage management station is connected directly to the controller tray, you must use an Ethernet crossover cable. An Ethernet crossover cable is a special cable that reverses the pin contacts between the two ends of the cable.

Procedure – Connecting Ethernet Cables

Perform these steps to connect Ethernet cables for out-of-band management. If you use only in-band management, skip these steps.

1. Connect one end of an Ethernet cable into the Ethernet port 1 on controller A.
2. Connect the other end to the applicable network connection.
3. Repeat step 1 through step 2 for controller B.

Step 9 – Connecting the Power Cords

The CDE2600 controller-drive tray, the DE1600 drive tray, and the DE5600 drive tray can have either standard power connections to an AC power source or the optional connections to a DC power source (–48 VDC).

IMPORTANT Make sure that you do not turn on the power to the controller-drive tray or the connected drive trays until this documentation instructs you to do so. For the correct procedure for turning on the power, see [“Step 10 – Turning on the Power and Checking for Problems in a CDE2600 Controller-Drive Tray Configuration.”](#)

Things to Know – AC Power Cords

- For each AC power connector on the drive tray, make sure that you use a separate power source in the cabinet. Connecting to independent power sources maintains power redundancy.
- To ensure proper cooling and assure availability, the drive trays always use two power supplies.
- You can use the power cords shipped with the controller-drive tray with typical outlets used in the destination country, such as a wall receptacle or an uninterruptible power supply (UPS). These power cords, however, are not intended for use in most EIA-compliant cabinets.

Things to Know – DC Power Cords

If your controller-drive trays have the DC power option installed, review the following information.

DC Power Cable

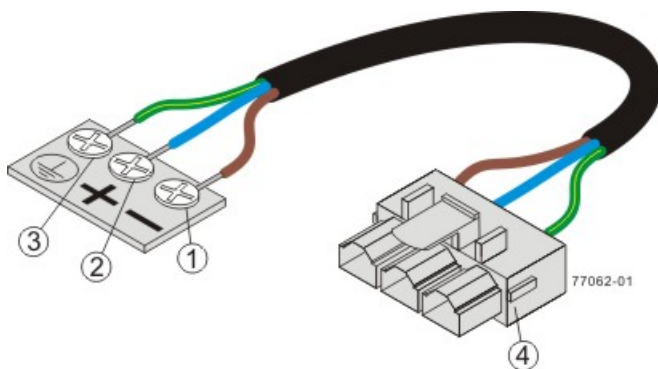

- Supply (negative), brown wire, –48 VDC
- Return (positive), blue wire
- Ground, green/yellow wire
- DC power connector

- Each power-fan canister has two DC power connectors. Be sure to use a separate power source for each power-fan canister in the drive tray to maintain power redundancy. You may, optionally, connect each DC power connector on the same power-fan canister to a different source for additional redundancy.
- A two-pole 30-amp circuit breaker is required between the DC power source and the drive tray for over-current and short-circuit protection.

WARNING (W14) **Risk of bodily injury** – A qualified service person is required to make the DC power connection according to NEC and CEC guidelines.

Procedure – Connecting AC Power Cords

1. Make sure that the circuit breakers in the cabinet are turned off.
2. Make sure that both of the Power switches on the controller-drive tray are turned off.
3. Connect the primary power cords from the cabinet to the external power source.
4. Connect a cabinet interconnect power cord (or power cords specific to your particular cabinet) to the AC power connector on each power canister in the drive tray.
5. If you are installing other drive trays in the cabinet, connect a power cord to each power canister in the drive trays.

Procedure – Connecting DC Power Cords



WARNING (W14) Risk of bodily injury – A qualified service person is required to make the DC power connection according to NEC and CEC guidelines.



NOTE Make sure that you do not turn on power to the controller-drive tray until this guide instructs you to do so. For the proper procedure for turning on the power, see .



NOTE Before turning off any power switches on a DC-powered controller-drive tray, you must disconnect the two-pole 20-amp circuit breaker.

1. Disconnect the two-pole 20-amp circuit breaker for the storage array.
2. Make sure that all of the DC power switches on the DC-powered controller-drive tray are turned off.
3. Make sure that all of the DC power switches on the DC-powered drive trays are turned off.
4. Connect the DC power connector cables to the DC power connectors on the rear of the controller-drive tray and the drive trays.



NOTE The three source wires on the DC power connector cable (–48 VDC) connect the controller-drive tray to centralized DC power plant equipment, typically through a bus bar located above the cabinet.



NOTE It is not mandatory that the second DC power connection on each of the drive tray's DC power-fan canisters be connected. The second DC power connection is for additional redundancy only and may be connected to a second DC power bus.

5. Have a qualified service person connect the other end of the DC power connector cables to the DC power plant equipment as follows:
 - a. Connect the brown –48 VDC supply wire to the negative terminal.
 - b. Connect the blue return wire to the positive terminal.
 - c. Connect the green/yellow ground wire to the ground terminal.

Step 10 – Turning on the Power and Checking for Problems in a CDE2600 Controller-Drive Tray Configuration

After you complete this task, you can install the software and perform basic configuration tasks on your storage array. Continue with the *Initial Configuration and Software Installation* in these electronic document topics or through the PDF that is available on the SANtricity ES Storage Manager Installation DVD.

Procedure – Turning On the Power to the Storage Array and Checking for Problems in a CDE2600 Controller-Drive Tray Configuration



IMPORTANT You must turn on the power to all of the connected drive trays before you turn on the power for the controller-drive tray. Performing this action makes sure that the controllers recognize each attached drive tray.



NOTE While the power is being applied to the trays, the LEDs on the front and the rear of the trays come on and go off intermittently.

1. Turn on both Power switches on each drive tray that is attached to the controller-drive tray. Depending on your configuration, it can take several minutes for each drive tray to complete the power-on process.



IMPORTANT Before you go to step 2, check the LEDs on the drive trays to verify that the power was successfully applied to all of the drive trays. Wait 30 seconds after turning on the power to the drive trays before turning on the power to the controller-drive tray.

2. Turn on both Power switches on the rear of the controller-drive tray. Depending on your configuration, it can take several minutes for the controller-drive tray to complete the power-on process.
3. Check the LEDs on the front and the rear of the controller-drive tray and the attached drive trays.
4. If you see any amber LEDs, make a note of their location.

Things to Know – LEDs on the CDE2600 Controller-Drive Tray

The following topics provide details on the LEDs found on the CDE2600 controller-drive tray.

LEDs on the Left End Cap

LEDs on the Left End Cap

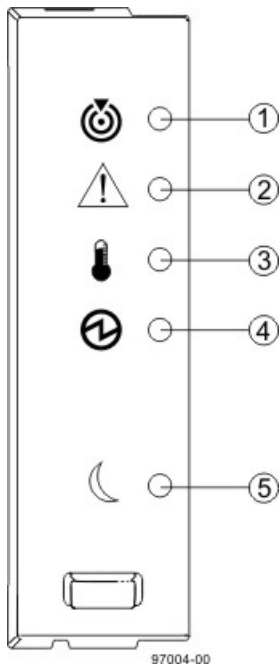

1. Controller-Drive Tray Locate LED
2. Service Action Required LED
3. Controller-Drive Tray Over-Temperature LED
4. Power LED
5. Standby Power LED

LEDs on the Left End Cap

| Location | LED | Color | On | Off |
|----------|--|-------|---|---|
| 1 | Controller-Drive Tray Locate | White | Identifies a controller-drive tray that you are trying to find. | Normal status. |
| 2 | Service Action Required | Amber | A component within the controller-drive tray needs attention. | Normal status. |
| 3 | Controller-Drive Tray Over-Temperature | Amber | The temperature of the controller-drive tray has reached an unsafe level. | Normal status. |
| 4 | Power | Green | Power is present. | Power is not present. |
| 5 | Standby Power | Green | The controller-drive tray is in Standby Power mode. | The controller-drive tray is not in Standby Power mode. |

LEDs on the Drive

LEDs on the Drive

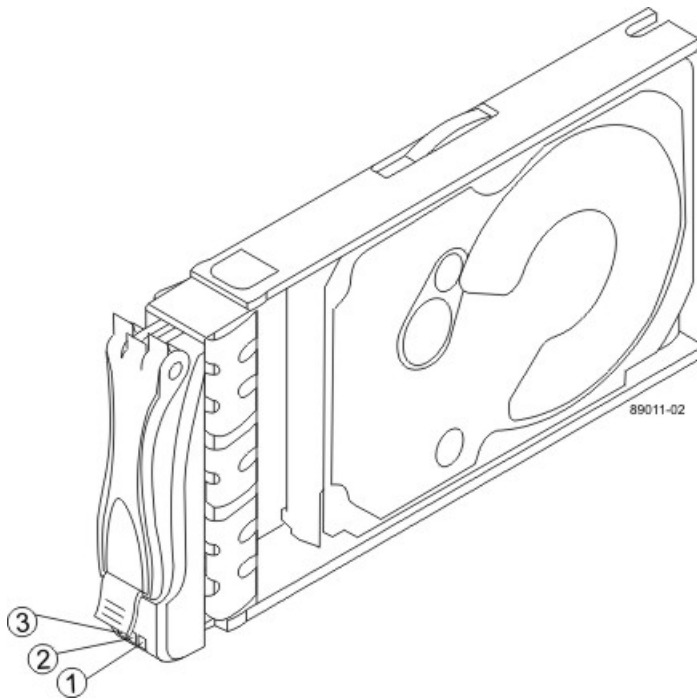

1. Drive Power LED
2. Drive Service Action Required LED
3. Drive Service Action Allowed LED

LEDs on the Drive

| Location | LED | Color | On | Blinking | Off |
|----------|-------------------------------|-------|--|-------------------------------------|---|
| 1 | Drive Power | Green | The power is turned on, and the drive is operating normally. | Drive I/O activity is taking place. | The power is turned off. |
| 2 | Drive Service Action Required | Amber | An error has occurred. | | Normal status. |
| 3 | Drive Service Action Allowed | Blue | The drive canister can be removed safely from the controller-drive tray. | | The drive canister cannot be removed safely from the controller-drive tray. |

Drive State Represented by LEDs

| Drive State | Drive Power LED (Green) | Drive Service Action Required LED (Amber) |
|---|-------------------------|---|
| Power is not applied. | Off | Off |
| Normal operation – The power is turned on, but drive I/O activity is not occurring. | On | Off |
| Normal operation – Drive I/O activity is occurring. | Blinking | Off |
| Service action required – A fault condition exists, and the drive is offline. | On | On |

LEDs on the Controller Canister Main Faceplate

LEDs on the Controller Canister Main Faceplate

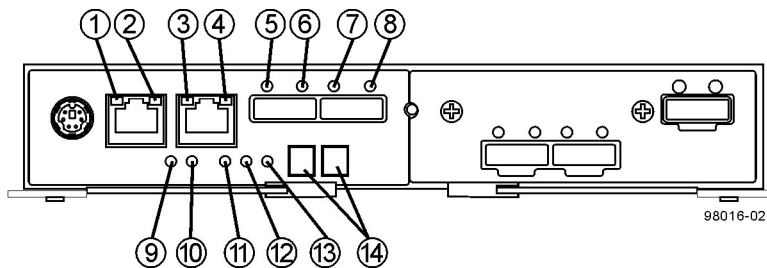

1. Ethernet Connector 1 Link Rate LED
2. Ethernet Connector 1 Link Active LED
3. Ethernet Connector 2 Link Rate LED
4. Ethernet Connector 1 Link Active LED
5. Host Link 1 Service Action Required LED
6. Host Link 1 Service Action Allowed LED
7. Host Link 2 Service Action Required LED
8. Host Link 2 Service Action Allowed LED
9. Battery Service Action Required LED
10. Battery Charging LED
11. Controller Service Action Allowed LED
12. Controller Service Action Required LED
13. Cache Active LED
14. Seven-Segment Tray ID

LEDs on the Controller Canister Main Faceplate

| Location | LED | Color | On | Off |
|----------|--------------------------------------|-------|---|---------------------------|
| 1 | Ethernet Connector 1 Link Rate LED | Green | There is a 100BASE-T rate. | There is a 10BASE-T rate. |
| 2 | Ethernet Connector 1 Link Active LED | Green | The link is up (LED blinks when there is activity). | The link is not active. |

| Location | LED | Color | On | Off |
|----------|---|-------|---|--|
| 3 | Ethernet Connector 2 Link Rate LED | Green | There is a 100BASE-T rate. | There is a 10BASE-T rate. |
| 4 | Ethernet Connector 2 Link Active LED | Green | The link is up (the LED blinks when there is activity). | The link is not active. |
| 5 | Host Link 1 Service Action Required LED | Amber | At least one of the four PHYs is working, but another PHY cannot establish the same link to the device connected to the Host IN port connector. | No link error has occurred. |
| 6 | Host Link 1 Service Action Allowed LED | Green | At least one of the four PHYs in the Host IN port is working and a link exists to the device connected to the IN port connector. | A link error has occurred. |
| 7 | Host Link 2 Service Action Required LED | Amber | At least one of the four PHYs is working, but another PHY cannot establish the same link to the device connected to the Host IN port connector. | No link error has occurred. |
| 8 | Host Link 2 Service Action Allowed LED | Green | At least one of the four PHYs in the Host IN port is working and a link exists to the device connected to the IN port connector. | A link error has occurred. |
| 9 | Battery Service Action Required LED | Amber | The battery in the controller canister has failed. | Normal status. |
| 10 | Battery Charging LED | Green | The battery is fully charged. The LED blinks when the battery is charging. | The controller canister is operating without a battery or the existing battery has failed. |
| 11 | Controller Service Action Allowed LED | Blue | The controller canister can be removed safely from the controller-drive tray. | The controller canister cannot be removed safely from the controller-drive tray. |

| Location | LED | Color | On | Off |
|----------|--|-------|--|---|
| 12 | Controller Service Action Required LED | Amber | A fault exists within the controller canister. | Normal status. |
| 13 | Cache Active LED | Green | Cache is active.* | Cache is inactive or the controller canister has been removed from the controller-drive tray. |

* After an AC power failure, this LED blinks while cache offload is in process.

LEDs on the Controller Canister Host Interface Card Subplates

NOTE The following figure shows an iSCSI host interface card (HIC), but the CDE2600 controller-drive tray also supports a four-connector FC HIC and a two-connector SAS HIC with comparable LEDs.

LEDs on the Controller Canister Host Interface Card Subplates

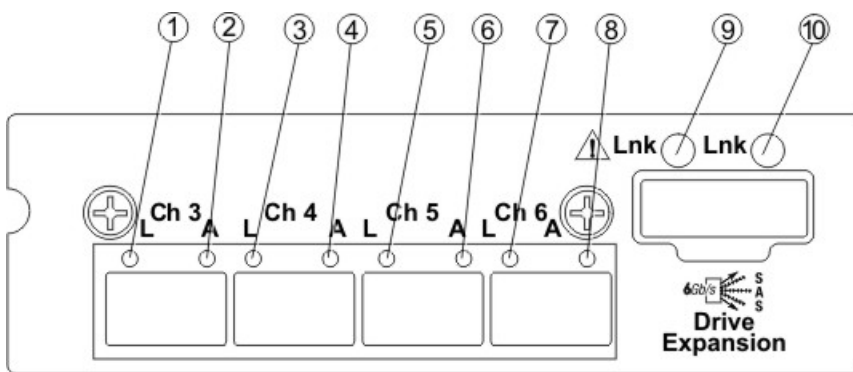

98019-09

1. Host Interface Card Link 3 Up LED
2. Host Interface Card Link 3 Active LED
3. Host Interface Card Link 4 Up LED
4. Host Interface Card Link 4 Active LED
5. Host Interface Card Link 5 Up LED
6. Host Interface Card Link 5 Active LED
7. Host Interface Card Link 6 Up LED
8. Host Interface Card Link 6 Active LED
9. Expansion Fault LED
10. Expansion Active LED

LEDs on the Controller Canister Host Interface Card Subplates*

| Location | LED | Color | On | Off |
|----------|---------------------------------------|-------|---|---|
| 1 | Host Interface Card Link 3 Up LED | Green | The Ethernet link has auto-negotiated to 1 Gb/s. | The Ethernet link is down or does not auto-negotiate to 1 Gb/s. |
| 2 | Host Interface Card Link 3 Active LED | Green | The link is up (LED blinks when there is activity). | The link is not active. |

| Location | LED | Color | On | Off |
|--|---------------------------------------|-------|---|---|
| 3 | Host Interface Card Link 4 Up LED | Green | The Ethernet link has auto-negotiated to 1 Gb/s. | The Ethernet link is down or does not auto-negotiate to 1 Gb/s. |
| 4 | Host Interface Card Link 4 Active LED | Green | The link is up (LED blinks when there is activity). | The link is not active. |
| 5 | Host Interface Card Link 5 Up LED | Green | The Ethernet link has auto-negotiated to 1 Gb/s. | The Ethernet link is down or does not auto-negotiate to 1 Gb/s. |
| 6 | Host Interface Card Link 5 Active LED | Green | The link is up (LED blinks when there is activity). | The link is not active. |
| 7 | Host Interface Card Link 6 Up LED | Green | The Ethernet link has auto-negotiated to 1 Gb/s. | The Ethernet link is down or does not auto-negotiate to 1 Gb/s. |
| 8 | Host Interface Card Link 6 Active LED | Green | The link is up (LED blinks when there is activity). | The link is not active. |
| 9 | Expansion Fault LED | Amber | At least one of the four PHY is working, but another PHY cannot establish the same link to the device connected to the Expansion OUT connector. | Normal status. |
| 10 | Expansion Active LED | Green | At least one of the four PHYs in the OUT connector is working and a link has been made to the device connected to the Expansion connector. | The link is not active. |
| * "LEDs on the Controller Canister Host Interface Card Subplates" shows the four-port iSCSI host interface card (HIC), which can also be a four-port FC HIC or a two-port SAS HIC. | | | | |

LEDs on the Power-Fan Canister

LEDs on the Power-Fan Canister

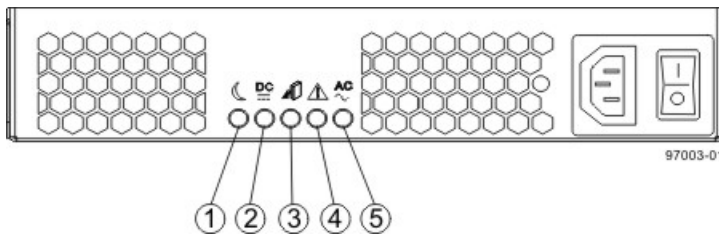





1. Standby Power LED
2. Power-Fan DC Power LED
3. Power-Fan Service Action Allowed LED
4. Power-Fan Service Action Required LED
5. Power-Fan AC Power LED







LEDs on the Power-Fan Canister



| Location | LED | Color | On | Off |
|----------|-----------------------------------|-------|--|---|
| 1 | Standby Power | Green | The controller-drive tray is in Standby mode, and DC power is not available. | The controller-drive tray is not in Standby mode, and DC power is available. |
| 2 | Power-Fan DC Power | Green | DC power from the power-fan canister is available. | DC power from the power-fan canister is not available. |
| 3 | Power-Fan Service Action Allowed | Blue | The power-fan canister can be removed safely from the controller-drive tray. | The power-fan canister cannot be removed safely from the controller-drive tray. |
| 4 | Power-Fan Service Action Required | Amber | A fault exists within the power-fan canister. | Normal status. |
| 5 | Power-Fan AC Power | Green | AC power to the power-fan canister is present. | AC power to the power-fan canister is not present. |

Things to Know – General Behavior of the LEDs on the CDE2600 Controller-Drive Tray

LED Symbols and General Behavior

| LED | Symbol | Location (Canisters) | Function |
|---------------------------------|---|---|---|
| Power |  | Power-fan Interconnect-battery | <ul style="list-style-type: none"> ▪ On – The controller has power. ▪ Off – The controller does not have power. <p>NOTE – The controller canisters do not have a Power LED. They receive their power from the power supplies inside the power-fan canisters.</p> |
| Battery Fault |  | Battery | <ul style="list-style-type: none"> ▪ On – The battery is missing or has failed. ▪ Off – The battery is operating normally. ▪ Blinking – The battery is charging. |
| Service Action Allowed |  | Drive (left LED, no symbol) Power-fan Controller Battery | <p>On – You can remove the canister safely. See “Things to Know – Service Action Allowed LEDs.”</p> |
| Service Action Required (Fault) |  | Drive | <p>On – When the drive tray LED is on, the cable is attached and at least one lane has a link up status, but at least one lane has a link down status.</p> <p>Off – One of the following conditions exists:</p> <ul style="list-style-type: none"> ▪ No cable is attached. ▪ A cable is attached, and all lanes have a link up status. ▪ A cable is attached, and all lanes have a link down status. |

| LED | Symbol | Location (Canisters) | Function |
|--|---|--|---|
| Service Action Required (Fault) |  | Controller Power-fan canister | On – The controller or the power-fan canister needs attention. Off – The controller and the power-fan canister are operating normally. |
| Locate |  | Front frame | On – Assists in locating the tray. |
| Host Channel Connection (iSCSI) |  | Controller | The status of the host channel is indicated: <ul style="list-style-type: none"> ▪ “L” LED on – A link is established. ▪ “A” LED on – Activity (data transfer) is present. |
| Cache Active |  | Controller | The activity of the cache is indicated: <ul style="list-style-type: none"> ▪ On – Data is in the cache. ▪ Off – No data is in the cache. |
| Controller-Drive Tray Over-Temperature |  | Front bezel on the controller-drive tray | On – The temperature of the drive tray has reached an unsafe condition. Off – The temperature of the drive tray is within operational range. |
| Standby Power |  | Front bezel on the controller-drive tray | On – The controller tray is in standby mode and the main DC power is off. Off – The controller-drive tray is not in standby mode and the main DC power is on. |
| Seven-Segment ID Diagnostic Display |  | Controller | The tray ID or a diagnostic code is indicated (see “Things to Know – Dynamic Display Sequence Definitions on the Seven-Segment Display”). For example, if some of the cache memory dual in-line memory modules (DIMMs) are missing in a controller, |

| LED | Symbol | Location (Canisters) | Function |
|--------------------------------------|---|---|--|
| | | | error code L8 appears in the diagnostic display (see “Things to Know – Supported Diagnostic Lock-Down Codes on the Seven-Segment Display”). |
| AC power | AC  | Power-fan NOTE – The LED is directly above or below the AC power switch and the AC power connector. | Indicates that the power supply is receiving AC power input. |
| DC power | DC  | Power-fan NOTE – The LED is directly above or below the DC power switch and the DC power connector. | Indicates that the power supply is receiving DC power input. |
| Ethernet Speed and Ethernet Activity |  | Controller | <p>The speed of the Ethernet ports and whether a link has been established are indicated:</p> <ul style="list-style-type: none"> ▪ Left LED On – 1-Gb/s speed. ▪ Left LED Off – 100BASE-T or 10BASE-T speed. ▪ Right LED On – A link is established. ▪ Right LED Off – No link exists. ▪ Right LED blinking – Activity is occurring. |

Things to Know – LEDs on the DE1600 Drive Tray and the DE5600 Drive Tray

LEDs on the Left End Cap

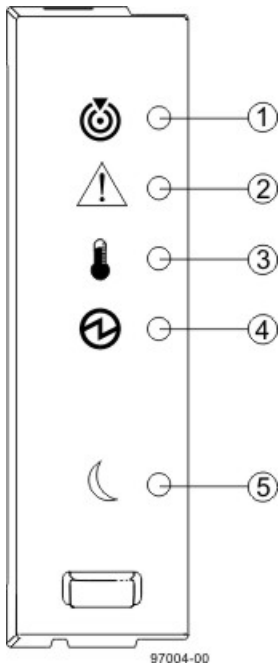

1. Drive Tray Locate LED
2. Drive Tray Service Action Required LED
3. Drive Tray Over-Temperature LED
4. Drive Tray Power LED
5. Drive Tray Standby Power LED

LEDs on the Left End Cap

| Location | LED | Color | On | Off |
|----------|------------------------------------|-------|--|--|
| 1 | Drive Tray Locate | White | Identifies a drive tray that you are trying to find. | Normal status. |
| 2 | Drive Tray Service Action Required | Amber | A component within the drive tray needs attention. | Normal status. |
| 3 | Drive Tray Over-Temperature | Amber | The temperature of the drive tray has reached an unsafe level. | Normal status. |
| 4 | Drive Tray Power | Green | Power is present. | Power is not present. |
| 5 | Drive Tray Standby Power | Green | The drive tray is in Standby Power mode. | The drive tray is not in Standby Power mode. |

LEDs on the Drive

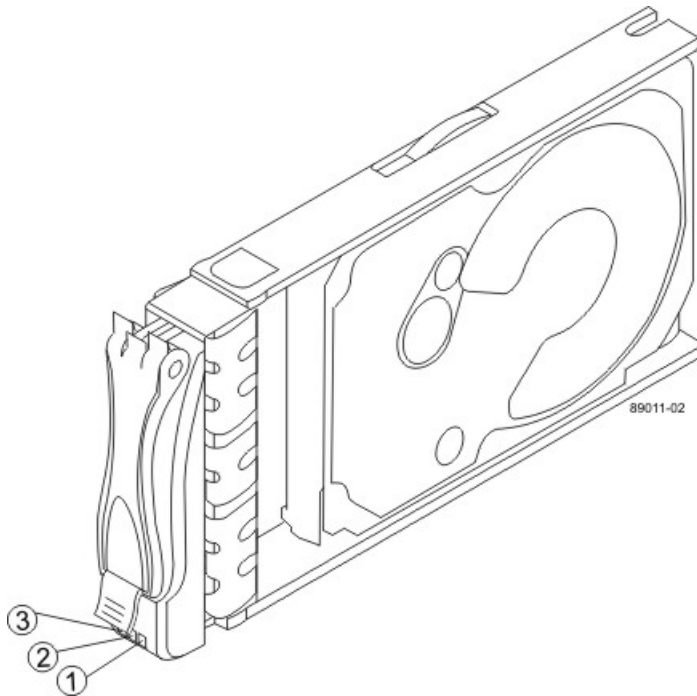

1. Drive Power LED
2. Drive Service Action Required LED
3. Drive Service Action Allowed LED

LEDs on the Drive

| Location | LED | Color | On | Blinking | Off |
|----------|-------------------------------|-------|---|-------------------------------------|--|
| 1 | Drive Power | Green | The power is turned on, and the drive is operating normally. | Drive I/O activity is taking place. | The power is turned off. |
| 2 | Drive Service Action Required | Amber | An error has occurred. | | Normal status. |
| 3 | Drive Service Action Allowed | Blue | The drive canister can be removed safely from the drive tray. | | The drive canister cannot be removed safely from the drive tray. |

Drive State Represented by LEDs

| Drive State | Drive Power LED (Green) | Drive Service Action Required LED (Amber) |
|-----------------------|-------------------------|---|
| Power is not applied. | Off | Off |

| Drive State | Drive Power LED (Green) | Drive Service Action Required LED (Amber) |
|---|-------------------------|---|
| Normal operation – The power is turned on, but drive I/O activity is not occurring. | On | Off |
| Normal operation – Drive I/O activity is occurring. | Blinking | Off |
| Service action required – A fault condition exists, and the drive is offline. | On | On |

LEDs on the ESM Canister

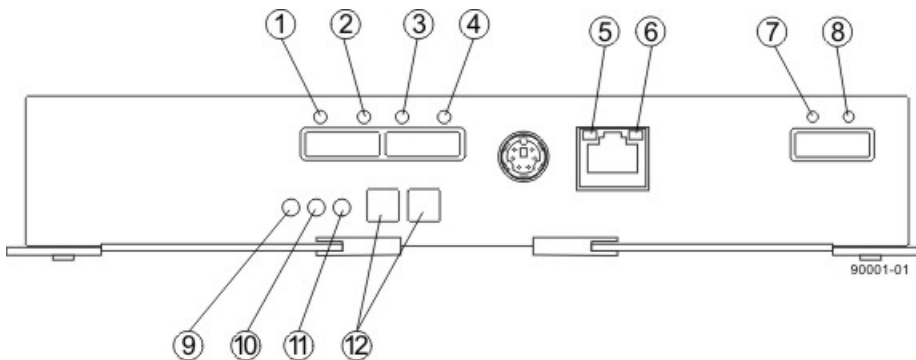

1. Host Link 1 Fault LED
2. Host Link 1 Active LED
3. Host Link 2 Fault LED
4. Host Link 2 Active LED
5. Ethernet Link Active LED
6. Ethernet Link Rate LED
7. ESM Expansion Link Fault LED
8. ESM Expansion Link Active LED
9. ESM Service Action Allowed LED
10. ESM Service Action Required LED
11. ESM Power LED
12. Seven-Segment Tray ID

LEDs on the ESM Canister

| Location | LED | Color | On | Off |
|----------|--------------------|-------|---|-----------------------------|
| 1 | Host Link 1 Fault | Amber | At least one PHY of the four connectors is working, but another PHY cannot establish the same link to the device connected to the Host IN port connector. | No link error has occurred. |
| 2 | Host Link 1 Active | Green | At least one of the four PHYs in the In port is working, and a link | A link error has occurred. |

| Location | LED | Color | On | Off |
|----------|-----------------------------|-------|---|---|
| | | | exists to the device connected to the Host In connector. | |
| 3 | Host Link 2 Fault | Amber | At least one PHY of the four connections is working, but another PHY cannot establish the same link to the device connected to the Host In port connector | No link error has occurred. |
| 4 | Host Link 2 Active | Green | At least one of the four PHYs in the IN port is working, and a link exists to the device connected to the Host In connector. | A link error has occurred. |
| 5 | Ethernet Link Active | Green | The link is up. (The LED blinks when there is activity.) | The link is not active. |
| 6 | Ethernet Link Rate | Green | There is a 100BASE-T rate. | There is a 10BASE-T rate. |
| 7 | ESM Expansion Link Fault | Amber | At least one of the four PHYs in the Out port is working, but another PHY cannot establish the same link to the Expansion Out connector. | Normal status. |
| 8 | ESM Expansion Link Active | Green | At least one of the four PHYs in the Out port is working, and a link exists to the device connected to the Expansion Out connector. | A link error has occurred. |
| 9 | ESM Service Action Allowed | Blue | The ESM can be removed safely from the drive tray. | The ESM cannot be removed safely from the drive tray. |
| 10 | ESM Service Action Required | Amber | A fault exists within the ESM. (This LED defaults on at power up. This LED turns off after the software has completed its power up self-test sequence.) | Normal status. |

| Location | LED | Color | On | Off |
|----------|-----------------------|-------|----------------------------------|----------------------------------|
| 11 | ESM Power | Green | 12V power to the ESM is present. | Power is not present to the ESM. |
| 12 | Seven-Segment Tray ID | Green | See note. | Not applicable. |

NOTE: For more information about the seven-segment tray IDs, see [Things to Know – Seven-Segment Display for the DE1600 Drive Tray and the DE5600 Drive Tray](#).

LEDs on the AC Power-Fan Canister

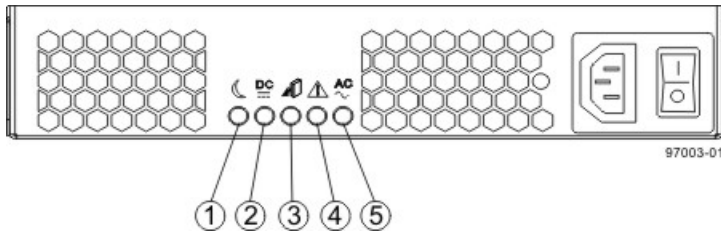

1. Standby Power LED
2. Power-Fan Output DC Power LED
3. Power-Fan Service Action Allowed LED
4. Power-Fan Service Action Required LED
5. Power-Fan Input AC Power LED

LEDs on the DC Power-Fan Canister

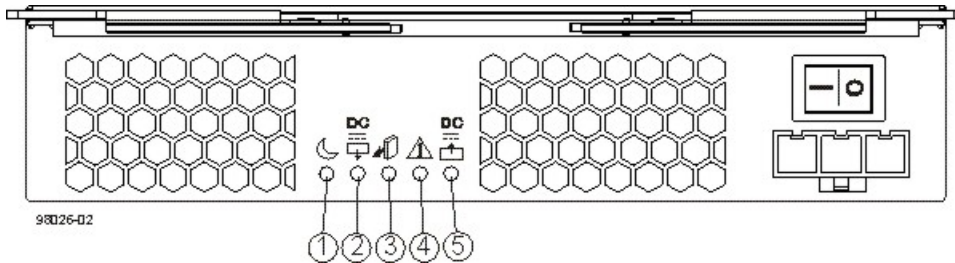

1. Standby Power LED
2. Power-Fan Output DC Power LED
3. Power-Fan Service Action Allowed LED
4. Power-Fan Service Action Required LED
5. Power-Fan Input DC Power LED





LEDs on the Power-Fan Canister





| Location | LED | Color | On | Off |
|----------|--------------------|-------|---|---|
| 1 | Standby Power | Green | The drive tray is in Standby mode, and DC power is not available. | The drive tray is not in Standby mode, and DC power is available. |
| 2 | Power-Fan DC Power | Green | DC power from the power-fan canister is available. | DC power from the power-fan canister is not available. |

| Location | LED | Color | On | Off |
|----------|-----------------------------------|-------|---|--|
| 3 | Power-Fan Service Action Allowed | Blue | The power-fan canister can be removed safely from the drive tray. | The power-fan canister cannot be removed safely from the drive tray. |
| 4 | Power-Fan Service Action Required | Amber | A fault exists within the power-fan canister. | Normal status. |
| 5 | Power-Fan AC Power | Green | AC power to the power-fan canister is present. | AC power to the power-fan canister is not present. |

General Behavior of the LEDs on the DE1600 Drive Tray, and the DE5600 Drive Tray

LED Symbols and General Behavior

| LED | Symbol | Location | General Behavior |
|-----------------------------|---|--|---|
| Power |  | Drive tray ESM canister Power-fan canister | On – Power is applied to the drive tray or the canister. Off – Power is not applied to the drive tray or the canister. |
| Drive Tray Locate |  | Front bezel on the drive tray | On or blinking – Indicates the drive tray that you are trying to find. |
| Drive Tray Over-Temperature |  | Front bezel on the drive tray | On – The temperature of the drive tray has reached an unsafe condition. Off – The temperature of the drive tray is within operational range. |
| Standby Power |  | Front bezel on the drive tray | On – The drive tray is in Standby mode, and the main DC power is off. Off – The drive tray is not in Standby mode, and the main DC power is on. |
| Service Action Allowed |  | ESM canister Power-fan canister Drive | On – It is safe to remove the ESM canister, the power-fan canister, or the drive. Off – Do not remove the ESM canister, the power-fan canister, or the drive. The drive has an LED but no symbol. |

| LED | Symbol | Location | General Behavior |
|--------------------------------------|---|---|---|
| Service Action Required (Fault) |  | ESM canister Power-fan canister Drive | On – When the drive tray LED is on, a component within the drive tray needs attention. On – The ESM canister, the power-fan canister, or the drive needs attention. Off – The ESM canister, the power-fan canister, and the drive are operating normally. The drive has an LED but no symbol. |
| AC Power | AC  | ESM canister Power-fan canister | On – AC power is present. Off – AC power is not present. |
| DC Power | DC  | Power-fan canister | On – Regulated DC power from the power canister and the fan canister is present. Off – Regulated DC power from the power-fan canister is not present. |
| Link Service Action Required (Fault) |  | ESM canister | On – The cable is attached and at least one lane has a link-up status, but one lane has a link-down status. Off – The cable is not attached, the cable is attached and all lanes have a link-up status, or the cable is attached and all lanes have a link-down status. |
| Link Up | Two LEDs above each expansion connector | ESM canister | On – The cable is attached and at least one lane has a link-up status. Off – The cable is not attached, or the cable is attached and all lanes have a link-down status. |

Things to Know – Service Action Allowed LEDs

Each controller canister, power-fan canister, and battery canister has a Service Action Allowed LED. The Service Action Allowed LED lets you know when you can remove a canister safely.



ATTENTION Possible loss of data access – Never remove a controller canister, a power-fan canister, or a battery canister unless the appropriate Service Action Allowed LED is on.

If a controller canister or a power-fan canister fails and must be replaced, the Service Action Required (Fault) LED on that canister comes on to indicate that service action is required. The Service Action Allowed LED also comes on if it is safe to remove the canister. If data availability dependencies exist or other conditions that dictate a canister should not be removed, the Service Action Allowed LED stays off.

The Service Action Allowed LED automatically comes on or goes off as conditions change. In most cases, the Service Action Allowed LED comes on when the Service Action Required (Fault) LED comes on for a canister.

 **NOTE** If the Service Action Required (Fault) LED comes on but the Service Action Allowed LED is off for a particular canister, you might need to service another canister first. Check your storage management software to determine the action that you should take.

Things to Know – Sequence Code Definitions for the CDE2600 Controller-Drive Tray

During normal operation, the tray ID display on each controller canister displays the controller-drive tray ID. The Diagnostic LED (lower-digit decimal point) comes on when the display is used for diagnostic codes and goes off when the display is used to show the tray ID.

Sequence Code Definitions for the CDE2600 Controller-Drive Tray

| Category | Category Code (See Note 1) | Detail Codes (See Note 2) |
|--------------------|----------------------------|---|
| Startup error | SE+ (See Note 3) | <ul style="list-style-type: none"> ▪ 88+ Power-on default. ▪ dF+ Power-on diagnostic fault. |
| Operational error | OE+ | Lx+ Lock-down codes. (See the following table.) |
| Operational state | OS+ | <ul style="list-style-type: none"> ▪ OL+ = Offline. ▪ bb+ = Battery backup (operating on batteries). ▪ Cf+ = Component failure. |
| Component failure | CF+ | <ul style="list-style-type: none"> ▪ dx+ = Processor or cache DIMM. ▪ Cx = Cache DIMM. ▪ Px+ = Processor DIMM. ▪ Hx+ = Host interface card. ▪ Fx+ = Flash drive. |
| Diagnostic failure | dE+ | Lx+ = Lock-down code. |
| Category delimiter | dash+ | The separator between category-detail code pairs is used when more than one category detail code pair exists in the sequence. |

| Category | Category Code (See Note 1) | Detail Codes (See Note 2) |
|--|----------------------------|--|
| End-of-sequence delimiter | Blank (See Note 4) | The end-of-sequence delimiter is automatically inserted by the hardware at the end of a code sequence. |
| Notes: 1 A two-digit code that starts a dynamic display sequence. 2 A two-digit code that follows the category code with more specific information. 3 The plus (+) sign indicates that a two-digit code displays with the Diagnostic LED on. 4 No codes display, and the Diagnostic LED is off. | | |

Things to Know – Lock-Down Codes for the CDE2600 Controller-Drive Tray

Use the following table to determine the diagnostic lock-down code definitions on the Seven-Segment Display in the controller canister for the CDE2600 controller-drive tray.

Supported Diagnostic Lock-Down Codes on the Seven-Segment Display

| Diagnostic Code | Description |
|-----------------|--|
| -- | The firmware is booting. |
| .8, 8., or 88 | This ESM is being held in reset by another ESM. |
| AA | The ESM A firmware is in the process of booting (the diagnostic indicator is not yet set). |
| bb | The ESM B firmware is in the process of booting (the diagnostic indicator is not yet set). |
| L0 | The controller types are mismatched, which result in a suspended controller state. |
| L2 | A persistent memory error has occurred, which results in a suspended controller state. |
| L3 | A persistent hardware error has occurred, which results in a suspended controller state. |
| L4 | A persistent data protection error has occurred, which results in a suspended controller state. |
| L5 | An auto-code synchronization (ACS) failure has been detected, which results in a suspended controller state. |
| L6 | An unsupported host interface card has been detected, which results in a suspended controller state. |

| Diagnostic Code | Description |
|-----------------|---|
| L7 | A sub-model identifier either has not been set or has been mismatched, which results in a suspended controller state. |
| L8 | A memory configuration error has occurred, which results in a suspended controller state. |
| L9 | A link speed mismatch condition has been detected in either the ESM or the power supply, which results in a suspended controller state. |
| Lb | A host interface card configuration error has been detected, which results in a suspended controller state. |
| LC | A persistent cache backup configuration error has been detected, which results in a suspended controller state. |
| Ld | A mixed cache memory DIMMs condition has been detected, which results in a suspended controller state. |
| LE | Uncertified cache memory DIMM sizes have been detected, which result in a suspended controller state. |
| LF | The controller has locked down in a suspended state with limited symbol support. |
| LH | A controller firmware mismatch been detected, which results in a suspended controller state. |
| LL | The controller cannot access either midplane SBB EEPROM, which results in a suspended controller state. |
| Ln | A canister is not valid for a controller, which results in a suspended controller state. |
| LP | Drive port mapping tables are not detected, which results in a suspended controller state. |
| LU | The start-of-day (SOD) reboot limit has been exceeded, which results in a suspended controller state. |

Things to Know – Diagnostic Code Sequences for the CDE2600 Controller-Drive Tray

Use the following table to determine the code sequences on the Seven-Segment Display in the controller canister for the CDE2600 controller-drive tray. These repeating sequences can be used to diagnose potential problems with the controller tray.

Diagnostic Code Sequences for the CDE2600 Controller-Drive Tray

| Displayed Diagnostic Code Sequences | Description |
|-------------------------------------|---|
| SE+ 88+ blank- | One of the following power-on conditions exists: <ul style="list-style-type: none"> ▪ Controller power-on ▪ Controller insertion ▪ Controller inserted while held in reset |
| xy - | Normal operation. |
| OS+ Sd+ blank- | Start-of-day (SOD) processing. |
| OS+ OL+ blank- | The controller is placed in reset while displaying the tray ID. |
| OS+ bb+ blank- | The controller is operating on batteries (cache backup). |
| OS+ CF+ Hx + blank- | A failed host card has been detected. |
| OS+ CF+ Fx + blank- | A failed flash drive has been detected. |
| SE+ dF + blank- | A non-replaceable component failure has been detected. |
| SE+ dF + dash+ CF+ Px + blank- | A processor DIMM failure has been detected. |
| SE+ dF + dash+ CF+ Cx + blank- | A cache memory DIMM failure has been detected. |
| SE+ dF + dash+ CF+ dx + blank- | A processor or cache DIMM failure has been detected. |
| SE+ dF + dash+ CF+ Hx + blank- | A host card failure has been detected. |
| OE+ Lx + blank- | A lockdown condition has been detected. |
| OE+ L2+ dash+ CF+ Px + blank- | Persistent processor DIMM ECC errors have been detected, which result in a suspended controller state. |
| OE+ L2+ dash+ CF+ Cx + blank- | Persistent cache DIMM ECC errors have been detected, which result in a suspended controller state. |
| OE+ L2+ dash+ CF+ dx + blank- | Persistent processor or cache DIMM ECC errors have been detected, which result in a suspended controller state. |

| Displayed Diagnostic Code Sequences | Description |
|-------------------------------------|--|
| OE+ LC+ blank- | The write-protect switch is set during cache restore, which results in a suspended controller state. |
| OE+ LC+ dd + blank- | The memory size is changed from bad data in the flash drives, which results in a suspended controller state. |
| DE+ L2+ dash+ CF+ Cx + blank- | A cache memory diagnostic has been reported failed, which results in a suspended controller state. |

Things to Know – Seven-Segment Display for the DE1600 Drive Tray and the DE5600 Drive Tray

During normal operation, the tray ID display on each ESM displays the drive tray ID. The Diagnostic LED (lower-digit decimal point) comes on when the display is used for diagnostic codes and goes off when the display is used to show the tray ID.

 **NOTE** If a power-on or reset occurs, the Diagnostic LED, the Heartbeat LED (upper-digit decimal point), and all seven segments of both digits come on. The Diagnostic LED remains on until the drive tray ID appears.

Supported Diagnostic Codes

| Diagnostic Code | ESM State | Description |
|-----------------|-----------|--|
| .8, 8., or 88 | Suspended | This ESM is being held in reset by another ESM. |
| L0 | Suspended | The ESM types are mismatched. |
| L2 | Suspended | A persistent memory error has occurred. |
| L3 | Suspended | A persistent hardware error has occurred. |
| L9 | Suspended | An over-temperature condition has been detected in either the ESM or the power supply. |
| LL | Suspended | The midplane SBB VPD EEPROM cannot be accessed. |
| Ln | Suspended | The ESM canister is not valid for this drive tray. |
| LP | Suspended | Drive port mapping tables are not found. |
| H0 | Suspended | An ESM Fibre Channel interface failure has occurred. |

| Diagnostic Code | ESM State | Description |
|-----------------|-----------|--|
| H1 | Suspended | An SFP transceiver speed mismatch (a 2-Gb/s SFP transceiver is installed when the drive tray is operating at 4 Gb/s) indicates that an SFP transceiver must be replaced. Look for the SFP transceiver with a blinking amber LED. |
| H2 | Suspended | The ESM configuration is invalid or incomplete, and it operates in a Degraded state. |
| H3 | Suspended | The maximum number of ESM reboot attempts has been exceeded. |
| H4 | Suspended | This ESM cannot communicate with the alternate ESM. |
| H5 | Suspended | A midplane harness failure has been detected in the drive tray. |
| H6 | Suspended | An ESM firmware failure has been detected. |
| H8 | | SFP transceivers are present in currently unsupported ESM slots, either 2A or 2B. Secondary trunking SFP transceiver slots 2A and 2B are not supported. Look for the SFP transceiver with the blinking amber LED, and remove it. |
| H9 | | A non-catastrophic hardware failure has occurred. The ESM is operating in a Degraded state. |
| J0 | Suspended | The ESM canister is incompatible with the drive tray firmware. |

CDE2600-60 Controller-Drive Tray Installation

This topic provides basic information for installing the CDE2600-60 controller-drive tray and the corresponding DE6600 drive tray in a storage array. After you complete these tasks, go to the *Initial Configuration and Software Installation* electronic document topics or the PDF on the SANtricity ES Storage Manager Installation DVD.

Step 1 – Preparing for a CDE2600-60 Controller-Drive Tray Installation

Storage arrays for 6-Gb/s SAS drives consist of a CDE2600-60 controller-drive tray, or a CDE2600-60 controller-drive tray and either one or two DE6600 drive trays in a cabinet. Use the instructions in this document to install the CDE2600-60 controller-drive trays and all necessary drive trays for your configuration.

The following table shows the various configuration options.

CDE2600-60 Controller-Drive Tray Options

| CDE2600-60 Configurations | Options |
|--|---|
| Duplex (two controllers) CDE2600-60 controller-drive tray without a host interface card | A maximum of 180 drives. A configuration of a single CDE2600-60 controller-drive tray attached to either one or two DE6600 drive trays, for a maximum of 180 drives in the storage array. Two 6-Gb/s host connectors. An 8-GB battery backup. |
| Duplex CDE2600-60 controller-drive tray with a host interface card | A maximum of 180 drives in the storage array. A configuration of a single CDE2600-60 controller-drive tray attached to either one or two DE6600 drive trays, for a maximum of 180 drives in the storage array. Two 6-Gb/s host connectors, in addition to one of the following host interface cards: <ul style="list-style-type: none"> ▪ Two 6-Gb/s SAS connectors ▪ Four 1-Gb/s iSCSI connectors ▪ Two 10-Gb/s iSCSI connectors ▪ Four 8-Gb/s FC connectors An 8-GB battery backup. |

 **ATTENTION Possible hardware damage** – To prevent electrostatic discharge damage to the tray, use proper antistatic protection when handling tray components.

Key Terms

storage array

A collection of both physical components and logical components for storing data. Physical components include drives, controllers, fans, and power supplies. Logical components include volume groups and volumes. These components are managed by the storage management software.

controller-drive tray

One tray with drives, one or two controllers, fans, and power supplies. The controller-drive tray provides the interface between a host and a storage array.

controller

A circuit board and firmware that is located within a controller tray or a controller-drive tray. A controller manages the input/output (I/O) between the host system and data volumes.

drive tray

One tray with drives, one or two environmental services monitors (ESMs), power supplies, and fans. A drive tray does not contain controllers.

environmental services monitor (ESM)

A canister in the drive tray that monitors the status of the components. An ESM also serves as the connection point to transfer data between the drive tray and the controller.

Small Form-factor Pluggable (SFP) transceiver

A component that enables Fibre Channel duplex communication between storage array devices. SFP transceivers can be inserted into host bus adapters (HBAs), controllers, and environmental services monitors (ESMs). SFP transceivers can support either copper cables (the SFP transceiver is integrated with the cable) or fiber-optic cables (the SFP transceiver is a separate component from the fiber-optic cable).

Gathering Items



Before you start installing the controller-drive tray, you must have installed the cabinet in which the controller-drive tray will be mounted.

Use the tables in this section to verify that you have all of the necessary items to install the controller-drive tray.

Basic Hardware

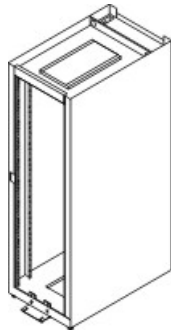
Basic Hardware

| | Item | Included with the Controller-Drive Tray |
|---|---|--|
|  | <p>Cabinet</p> <ul style="list-style-type: none"> ▪ Make sure that your cabinet meets the installation site specifications of the various CDE2600-60 storage array components. Refer to the <i>Storage System Site Preparation Guide</i> for more information. ▪ Depending on the power supply limitations of your cabinet, you might need to install more than one cabinet to accommodate the different components of the CDE2600-60 storage array. Refer to the installation guide for your cabinet for instructions on installing the cabinet. | |





| | Item | Included with the Controller-Drive Tray |
|---|---|---|
|  | DE6600 drive tray (shown with the separately packaged mounting rails attached). | ✓ |
|  | Mounting rails and screws. The mounting rails that are available with the drive tray are designed for an industry-standard cabinet. | |
| | Fibre Channel switch (optional). SAS switch (optional). | |
| | Gigabit Ethernet switch (optional). | |
| | <ul style="list-style-type: none"> ▪ Host with Fibre Channel host bus adapters (HBAs) (optional). ▪ Host with iSCSI HBAs (optional) or a network interface card (optional). ▪ Host with SAS HBAs (optional). | |

CDE2600 Configuration Cables and Connectors

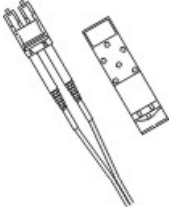
Cables and Connectors

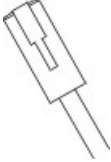
| | Item | Included with the Controller-Drive Tray or Drive Trays |
|---|---|--|
|  | AC power cords. The controller-drive tray and the drive trays ship with power cords for connecting to an external power source, such as a wall plug. Your cabinet might have special power cords that you use instead of the power cords that ship with the controller-drive tray and the drive trays. | ✓ |
| | <p>(Optional) Two DC power connector cables are provided with each drive tray for connection to centralized DC power plant equipment.</p> <ul style="list-style-type: none"> ▪ Four DC power connector cables are provided if additional redundancy is required. | ✓ For the DC power option only |

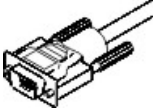
| | Item | Included with the Controller-Drive Tray or Drive Trays |
|--|---|--|
| | <ul style="list-style-type: none"> ▪ A qualified service person is required to make the DC power connection per NEC and CEC guidelines. A two-pole 20-amp circuit breaker is required between the DC power source and the drive tray for over-current and short-circuit protection. Before turning off any power switches on a DC-powered drive tray, first you must disconnect the two-pole 20-amp circuit breaker. | |
| | <p>Copper SAS cables - Use for all drive-side connections within the storage array.</p> <p>Fiber-optic cables - Use for FC connections to the drive trays.</p> <p>For the differences between the fiber-optic cables and the copper Fibre Channel (FC) cables, see Things to Know – SFP Transceivers, Fiber-Optic Cables, Copper Cables, and SAS Cables .</p> | |
|  | <p>Small Form-factor Pluggable (SFP) transceivers</p> <ul style="list-style-type: none"> ▪ The SFP transceivers connect fiber-optic cables to host ports and drive ports. ▪ Four or eight SFP transceivers are included with the controller-drive tray; one for each of the host channel ports on the controllers. ▪ Depending on your connection requirements, you might need to purchase additional SFP transceivers (two SFP transceivers for each fiber-optic cable). ▪ Depending on the configuration of your storage array, you might need to use various combinations of four different types of SFP transceivers: 8-Gb/s Fibre Channel, 6-Gb/s SAS, 1-Gb/s iSCSI, or 10-Gb/s iSCSI. These SFP transceivers are not generally interchangeable. ▪ You must purchase <i>only</i> Restriction of Hazardous Substances (RoHS)-compliant SFP transceivers. | ✓ |
| | <p>Copper Fibre Channel cables (optional)</p> <p>Use these cables for connections within the storage array.</p> <p>For the differences between the fiber-optic cables and the copper Fibre Channel cables, see “Things to Know – SFP Transceivers, Fiber-Optic Cables, Copper Cables, and SAS Cables.”</p> | ✓ |

| | Item | Included with the Controller-Drive Tray or Drive Trays |
|---|---|--|
|  | <p>Ethernet cable This cable is used for out-of-band storage array management and for 1-Gb/s iSCSI connections. For information about out-of-band storage array management, see the description for "Deciding on the Management Method" in <i>Initial Configuration and Software Installation</i> electronic document topics or the PDF on the SANtricity ES Storage Manager Installation DVD.</p> | |
|  | <p>SAS cables The SAS cables connect the host to the controller-drive tray. If you install a drive tray, you must use SAS cables to connect the controller-drive tray to the drive tray.</p> | |
|  | <p>Serial cable This cable is used for support only. You do not need to connect it during initial installation.</p> | |
|  | <p>DB9-to-PS2 adapter cable This cable adapts the DB9 connector on commercially available serial cables to the PS2 connector on the controller.</p> | |

Product DVDs

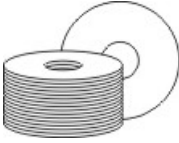

Product DVDs

| | Item | Included with the Controller-Drive Tray |
|---|---|---|
|  | <p>Firmware DVD</p> <ul style="list-style-type: none"> Firmware is already installed on the controllers. The files on the DVD are backup copies. <p>SANtricity ES Storage Manager Installation DVD</p> <ul style="list-style-type: none"> SANtricity ES Storage Manager software and documentation. To access product documentation, use the documentation map file, <code>doc_launcher.html</code>, which is located in the <code>docs</code> directory. | ✓ |

Tools and Other Items

Tools and Other Items

| | Item | Included with the Tray |
|---|--|------------------------|
| | <p>Labels</p> <p>Help you to identify cable connections and lets you more easily trace cables from one tray to another</p> | |
| | <p>A cart</p> <p>Holds the tray and components</p> | |
| | <p>A mechanical lift (optional)</p> | |
|  | <p>A Phillips screwdriver</p> | |

| | Item | Included with the Tray |
|--|--------------------------|------------------------|
|  | A flat-blade screwdriver | |
|  | Anti-static protection | |
| | A flashlight | |
| <p>Use the Compatibility Matrix, at the following website, to obtain the latest hardware compatibility information. http://www.lsi.com/compatibilitymatrix/</p> | | |

Things to Know – SFP Transceivers, Fiber-Optic Cables, Copper Cables, and SAS Cables

The figures in this topic display the fiber-optic cables, copper cables, SFP transceivers., and SAS cables with a SFF-8088 Connector.

 **NOTE** Your SFP transceivers and cables might look slightly different from the ones shown. The differences do not affect the performance of the SFP transceivers.

The controller-drive tray supports SAS, Fibre Channel (FC), and iSCSI host connections and SAS drive connections. FC host connections can operate at 8 Gb/s or at a lower data rate. Ports for 8-Gb/s Fibre Channel host connections require SFP transceivers designed for this data rate. These SFP transceivers look similar to other SFP transceivers but are not compatible with other types of connections. SFP transceivers for 1-Gb/s iSCSI and 10-Gb/s iSCSI connections have a different physical interface for the cable and are not compatible with other types of connections.

 **WARNING (W03) Risk of exposure to laser radiation** – Do not disassemble or remove any part of a Small Form-factor Pluggable (SFP) transceiver because you might be exposed to laser radiation.

Fiber-Optic Cable Connection

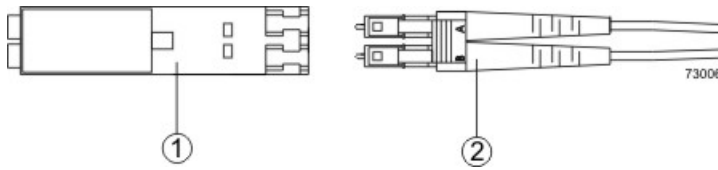

1. Active SFP Transceiver
2. Fiber-Optic Cable

1-Gb/s iSCSI Cable Connection

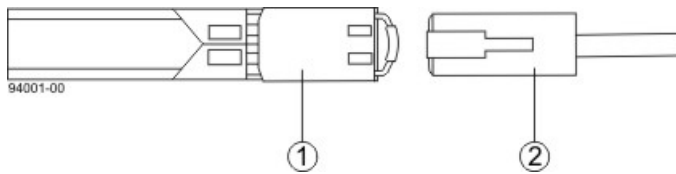

1. Active SFP Transceiver
2. Copper Cable with RJ-45 Connector

Copper Fibre Channel Cable Connection

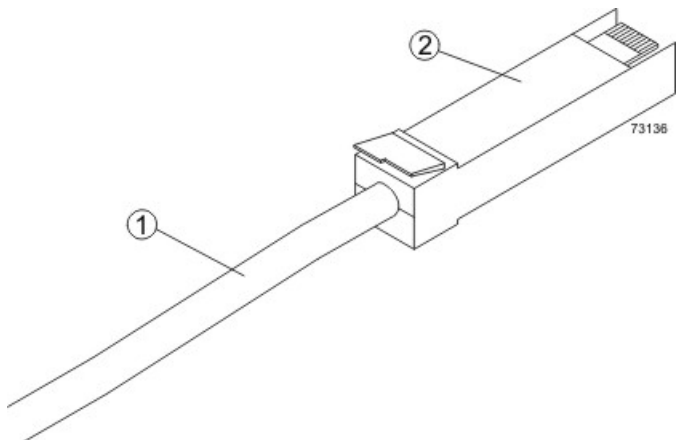

1. Copper Fibre Channel Cable
2. Passive SFP Transceiver

SAS Cable Connection

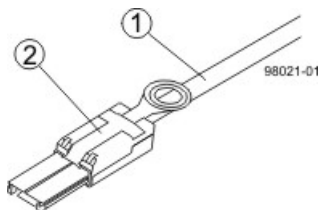

1. SAS Cable
2. SFF-8088 Connector

Things to Know – Taking a Quick Glance at the Hardware in a CDE2600-60 Controller-Drive Tray Configuration

WARNING (W14) Risk of bodily injury – A qualified service person is required to make the DC power connection according to NEC and CEC guidelines.

CAUTION (C05) Electrical grounding hazard – This equipment is designed to permit the connection of the DC supply circuit to the earthing conductor at the equipment.

NOTE Each tray in the storage array must have a minimum of two drives for proper operation. If the tray has fewer than two drives, a power supply error is reported.

- The top of the controller-drive tray is the side with labels.
- The configuration of the host ports might appear different on your system depending on which host interface card configuration is installed.

CDE2600-60 Controller-Drive Tray – Front View

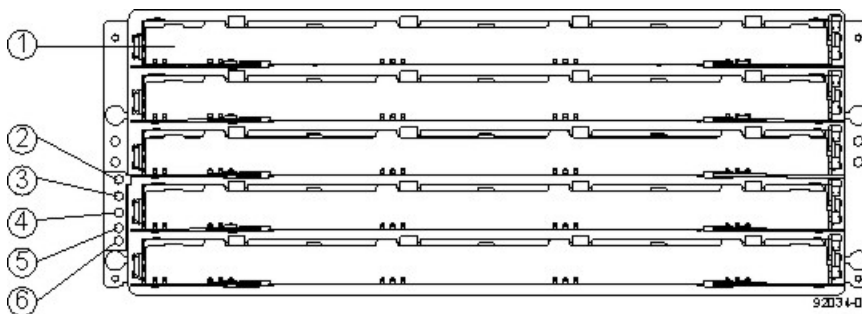

1. Drive Drawer
2. End Cap Locate LED
3. End Cap Service Action Required LED
4. End Cap Over-Temperature LED
5. End Cap Power LED
6. End Cap Standby Power LED

CDE2600-60 Controller-Drive Tray Duplex Configuration– Rear View

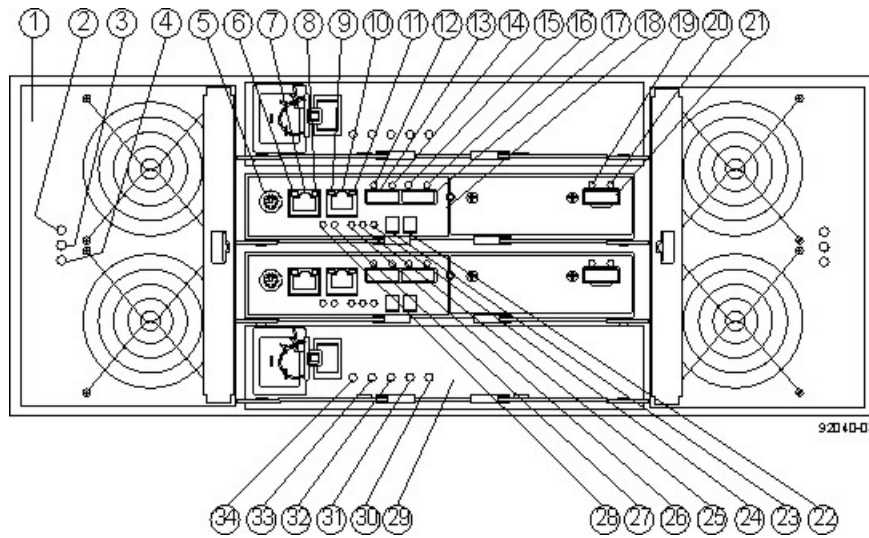

1. Fan Canister
2. Fan Canister Power LED
3. Fan Canister Service Action Required LED
4. Fan Canister Service Action Allowed LED
5. Serial Connector
6. Ethernet Link 1 Active LED
7. Ethernet Connector 1
8. Ethernet Link 1 Rate LED
9. Ethernet Link 2 Active LED
10. Ethernet Connector 2
11. Ethernet Link 2 Rate LED
12. Host Link 2 Fault LED
13. Base Host SFF-8088 Connector 2
14. Host Link 2 Active LED
15. Host Link 1 Fault LED
16. Host Link 1 Active LED
17. Base Host SFF-8088 Connector 1
18. Controller A Canister
19. ESM Expansion Fault LED
20. ESM Expansion Active LED
21. Expansion SFF-8088 Port Connector
22. Second Seven-Segment Display Field
23. First Seven-Segment Display Field
24. Cache Active LED
25. Controller A Service Action Required LED
26. Controller A Service Action Allowed LED
27. Battery Service Action Required LED
28. Battery Charging LED
29. Power Canister
30. Power Canister AC Power LED
31. Power Canister Service Action Required LED
32. Power Canister Service Action Allowed LED
33. Power Canister DC Power LED
34. Power Canister Standby Power LED

CDE2600-60 Right-Rear Subplate with No Host Interface Card



98019-04

1. ESM Expansion Fault LED
2. ESM Expansion Active LED
3. Expansion SFF-8088 Port Connector

CDE2600-60 Right-Rear Subplate with a SAS Host Interface Card

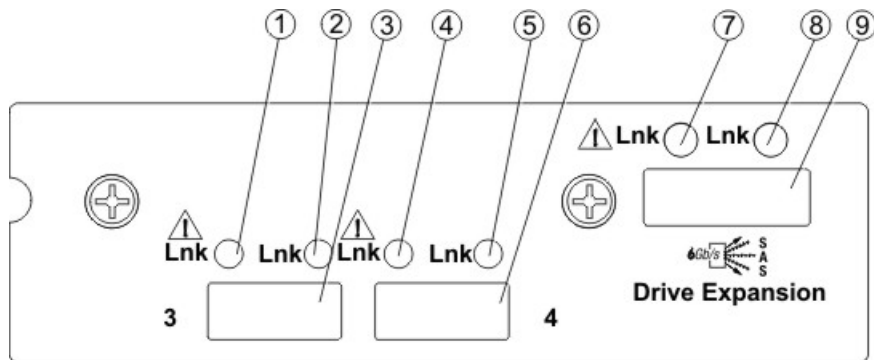

98019-03

1. Host Interface Card Link 3 Up LED
2. Host Interface Card Link 3 Active LED
3. SFF-8088 Host Interface Card Connector 3
4. Host Interface Card Link 4 Up LED
5. Host Interface Card Link 4 Active LED
6. SFF-8088 Host Interface Card Connector 4
7. ESM Expansion Fault LED
8. ESM Expansion Active LED
9. Expansion SFF-8088 Port Connector

CDE2600-60 Right-Rear Subplate with an FC Host Interface Card

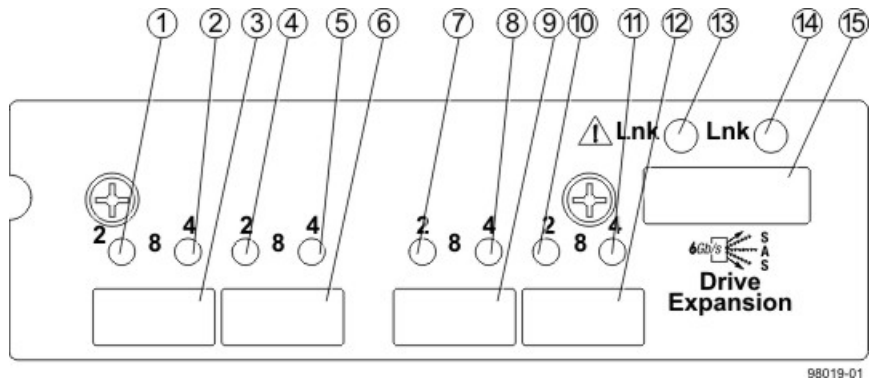

1. Host Interface Card Link 3 Up LED
2. Host Interface Card Link 3 Active LED
3. FC Host Interface Card Connector 3
4. Host Interface Card Link 4 Up LED
5. Host Interface Card Link 4 Active LED
6. FC Host Interface Card Connector 4
7. Host Interface Card Link 5 Up LED
8. Host Interface Card Link 5 Active LED
9. FC Host Interface Card Connector 5
10. Host Interface Card Link 6 Up LED
11. Host Interface Card Link 6 Active LED
12. FC Host Interface Card Connector 6
13. ESM Expansion Fault LED
14. ESM Expansion Active LED
15. Expansion SFF-8088 Port Connector

CDE2600-60 Right-Rear Subplate with a 1-Gb iSCSI Host Interface Card

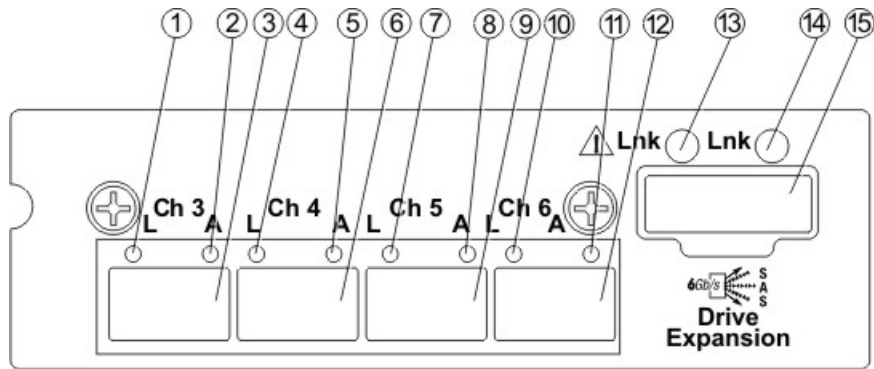

98019-02

1. Host Interface Card Link 3 Up LED
2. Host Interface Card Link 3 Active LED
3. iSCSI Host Interface Card Connector 3
4. Host Interface Card Link 4 Up LED
5. Host Interface Card Link 4 Active LED
6. iSCSI Host Interface Card Connector 4
7. Host Interface Card Link 5 Up LED
8. Host Interface Card Link 5 Active LED
9. iSCSI Host Interface Card Connector 5
10. Host Interface Card Link 6 Up LED
11. Host Interface Card Link 6 Active LED
12. iSCSI Host Interface Card Connector 6
13. ESM Expansion Fault LED
14. ESM Expansion Active LED
15. Expansion SFF-8088 Port Connector

CDE2600-60 Right-Rear Subplate with a 10-Gb iSCSI Host Interface Card

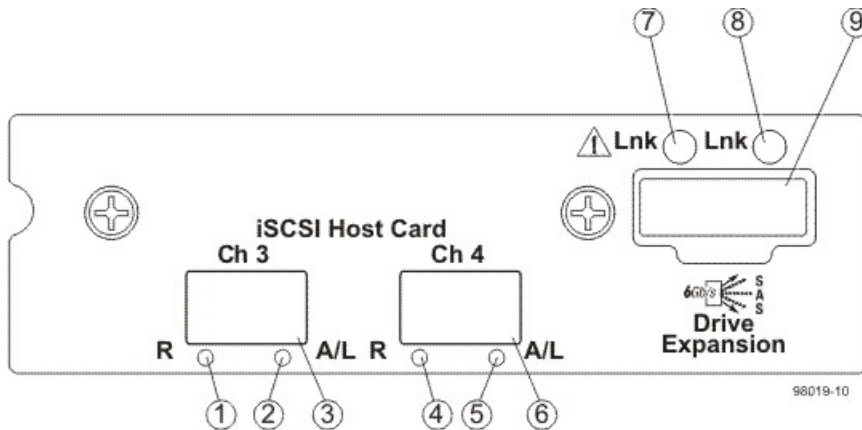

1. Host Interface Card Link 3 Up LED
2. Host Interface Card Link 3 Active LED
3. iSCSI Host Interface Card Connector 3
4. Host Interface Card Link 4 Up LED
5. Host Interface Card Link 4 Active LED
6. iSCSI Host Interface Card Connector 4
7. ESM Expansion Fault LED
8. ESM Expansion Active LED
9. Expansion SFF-8088 Port Connector

⚠ ATTENTION Possible equipment damage – You must use the supported drives in the drive tray to ensure proper performance. For information on supported drives, contact a Customer and Technical Support representative.

⚠ ATTENTION Risk of equipment malfunction – To avoid exceeding the functional and environmental limits, install only drives that have been provided or approved by the original manufacturer. Not all controller-drive trays are shipped with prepopulated drives. System integrators, resellers, system administrators, or users of the controller-drive tray can install the drives.

DE6600 Drive Tray – Front View with Bezel

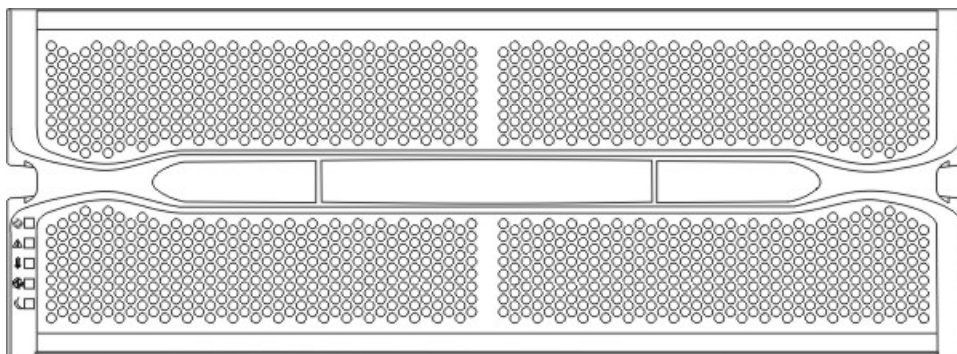

92036-01

DE6600 Drive Tray – Front View with Bezel Removed

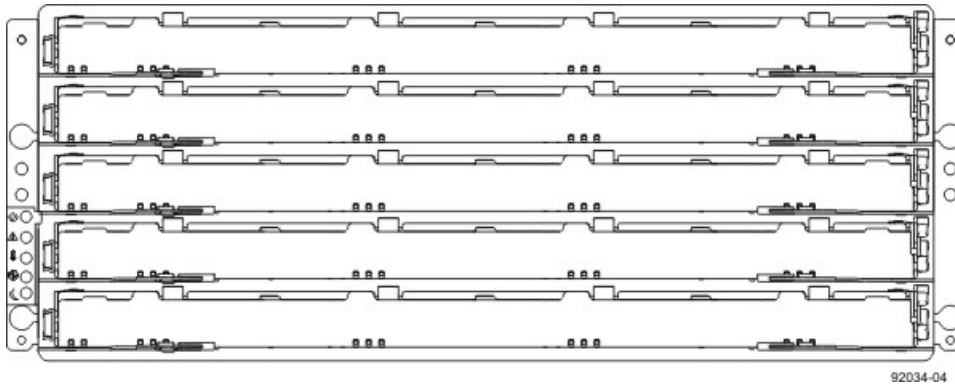

DE6600 Drive Tray – Rear View

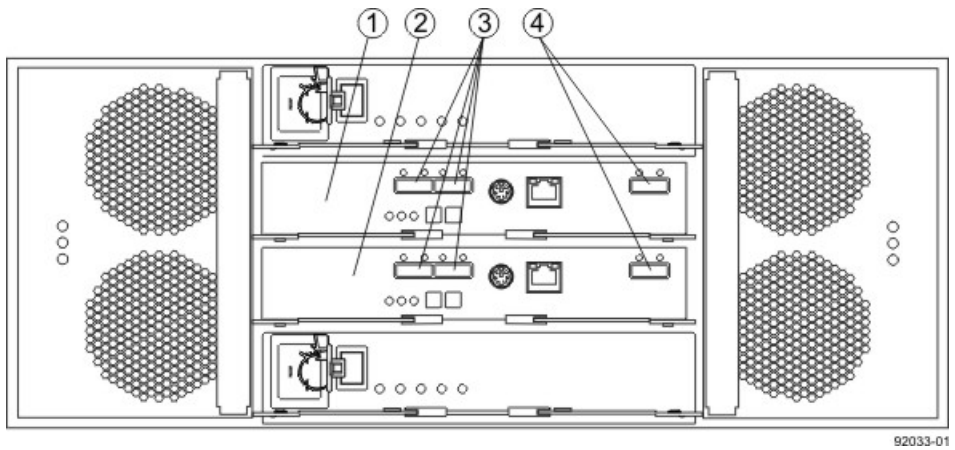

1. ESM A
2. ESM B
3. SAS IN Connectors
4. Expansion Connectors

For Additional Information on the CDE2600-60 Controller-Drive Tray Configuration

Refer to the *Storage System Site Preparation Guide* on the SANtricity ES Storage Manager Installation DVD for information about the installation requirements of the various CDE2600-60 storage array components.

Step 2 – Installing and Configuring the Switches

Things to Know – Switches



IMPORTANT Most of the switches, as shipped from the vendor, require an update to their firmware to work correctly with the storage array.

Depending on the configuration of your storage array, you might use Fibre Channel switches and iSCSI switches.

The switches in the following table are certified for use with a CDE2600 storage array, a CDE2600-60 storage array, a CDE4900 storage array, and a CE7900 storage array, which all use SANtricity ES Storage Manager Version 10.77.

Supported Switches

| Vendor | Model | Fibre Channel | iSCSI | SAS |
|---------|-------|---------------|-------|-----|
| Brocade | 200E | Yes | No | No |
| | 3200 | Yes | No | No |
| | 3800 | Yes | No | No |
| | 3900 | Yes | No | No |
| | 3950 | Yes | No | No |
| | 12000 | Yes | No | No |
| | 3850 | Yes | No | No |
| | 3250 | Yes | No | No |
| | 24000 | Yes | No | No |
| | 4100 | Yes | No | No |
| | 48000 | Yes | No | No |
| | 5000 | Yes | No | No |
| | 300 | Yes | No | No |
| | 5100 | Yes | No | No |
| | 5300 | Yes | No | No |
| | 7500 | Yes | No | No |
| | 7800 | Yes | No | No |
| DCX | Yes | No | No | |

| Vendor | Model | Fibre Channel | iSCSI | SAS |
|--------|---------------------|---------------|-------|-----|
| | FCOE | No | Yes | No |
| Cisco | 9506 | Yes | No | No |
| | 9509 | Yes | No | No |
| | 9216 | Yes | No | No |
| | 9216i | Yes | No | No |
| | 9120 | Yes | No | No |
| | 914x | Yes | No | No |
| | 9513 | Yes | No | No |
| | 9020 | Yes | No | No |
| | MDS9000 | Yes | No | No |
| | 9222i | Yes | No | No |
| | 9134 | Yes | No | No |
| | Catalyst 2960 | No | Yes | No |
| | Catalyst 3560 | No | Yes | No |
| | Catalyst 3750G-24TS | No | Yes | No |
| LSI | 6160 | No | No | Yes |
| McData | 3232 | Yes | No | No |
| | 3216 | Yes | No | No |
| | 4300 | Yes | No | No |
| | 4500 | Yes | No | No |
| | 6064 | Yes | No | No |
| | 6140 | Yes | No | No |
| | 4400 | Yes | No | No |
| | 4700 | Yes | No | No |
| QLogic | 6140 | No | Yes | No |
| | 6142 | No | Yes | No |
| | SANbox2-8 | Yes | No | No |

| Vendor | Model | Fibre Channel | iSCSI | SAS |
|--------------|------------|---------------|-------|-----|
| | SANbox2-16 | Yes | No | No |
| | SANbox5200 | Yes | No | No |
| | SANbox3600 | Yes | No | No |
| | SANbox3800 | Yes | No | No |
| | SANbox5208 | Yes | No | No |
| | SANbox5600 | Yes | No | No |
| | SANbox5800 | Yes | No | No |
| | SANbox9000 | Yes | No | No |
| PowerConnect | 5324 | No | Yes | No |
| | 6024 | No | Yes | No |

If required, make the appropriate configuration changes for *each* switch that is connected to the storage array.

Refer to the switch's documentation for information about how to install the switch and how to use the configuration utilities that are supplied with the switch.

Procedure – Installing and Configuring Switches

1. Install your switch according to the vendor's documentation.
2. Use the Compatibility Matrix at the website <http://www.lsi.com/compatibilitymatrix/> to obtain this information:
 - The latest hardware compatibility information
 - The models of the switches that are supported
 - The firmware requirements and the software requirements for the switches
3. Update the switch's firmware by accessing it from the applicable switch vendor's website.

This update might require that you cycle power to the switch.

4. Find your switch in the following table to see whether you need to make further configuration changes. Use your switch's configuration utility to make the changes.

Supported Switch Vendors and Required Configuration Changes

| Switch Vendor | Configuration Changes Required? | Next Step |
|---------------|---|---|
| Brocade | Yes Change the In-Order Delivery (IOD) option to ON. | Make the change, and go to "Step 3 – Installing the Host Bus Adapters for the CDE2600 Controller-Drive Tray." |

| Switch Vendor | Configuration Changes Required? | Next Step |
|---------------|---|---|
| Cisco | Yes Change the In-Order Delivery (IOD) option to ON. | Make the change, and go to “Step 3 – Installing the Host Bus Adapters for the CDE2600 Controller-Drive Tray.” |
| LSI | No | “Step 3 – Installing the Host Bus Adapters for the CDE2600 Controller-Drive Tray.” |
| McData | No | “Step 3 – Installing the Host Bus Adapters for the CDE2600 Controller-Drive Tray.” |
| QLogic | No | “Step 3 – Installing the Host Bus Adapters for the CDE2600 Controller-Drive Tray.” |
| PowerConnect | No | “Step 3 – Installing the Host Bus Adapters for the CDE2600 Controller-Drive Tray.” |

Step 3 – Installing the Host Bus Adapters for the CDE2600 Controller-Drive Tray

Key Terms

HBA host port

The physical and electrical interface on the host bus adapter (HBA) that provides for the connection between the host and the controller. Most HBAs will have either one or two host ports. The HBA has a unique World Wide Identifier (WWID) and each HBA host port has a unique WWID.

HBA host port world wide name

A 16-character unique name that is provided for each port on the host bus adapter (HBA).

host bus adapter (HBA)

A physical board that resides in the host. The HBA provides for data transfer between the host and the controllers in the storage array over the I/O host interface. Each HBA contains one or more physical ports.

Things to Know – Host Bus Adapters and Ethernet Network Interface Cards

- The CDE2600 controller-drive tray supports dual 6-Gb/s SAS host connections and optional host interface cards (HICs) for dual 6-Gb/s SAS, four 1-Gb/s iSCSI, two 10-Gb iSCSI, and four 8-Gb/s FC connections. The connections on a host must match the type (SAS HBAs for SAS, FC HBAs for FC, or iSCSI HBAs or Ethernet network interface cards [NICs] for iSCSI) of the HICs to which you connect them. For the best performance, HBAs for SAS and FC connections should support the highest data rate supported by the HICs to which they connect.
- For maximum hardware redundancy, you must install a minimum of two HBAs (for either SAS or FC host connections) or two NICs or iSCSI HBAs (for iSCSI host connections) in each host. Using both ports of a dual-port HBA or a dual-port NIC provides two paths to the storage array but does not ensure redundancy if an HBA or a NIC fails.



NOTE You can use the Compatibility Matrix to obtain information about the supported models of the HBAs and their requirements. Go to <http://www.lsi.com/compatibilitymatrix/>, and select the desired Developer Partner Program link. Check its Compatibility Matrix to make sure you have an acceptable configuration.

- Most of the HBAs, as shipped from the vendor, require updated firmware and software drivers to work correctly with the storage array. For information about the updates, refer to the website of the HBA vendor.

Procedure – Installing Host Bus Adapters

1. Go to <http://www.lsi.com/compatibilitymatrix/>, and select the desired Developer Partner Program link. Check its Compatibility Matrix to make sure you have an acceptable configuration.

The Compatibility Matrix provides this information:

- The latest hardware compatibility information
- The models of the HBAs that are supported
- The firmware requirements and the software requirements for the HBAs

2. Install your HBA according to the vendor documentation.



NOTE If your operating system is Windows Server 2008 Server Core, you might have additional installation requirements. Refer to the Microsoft Developers Network (MSDN) for more information about Windows Server 2008 Server Core. You can access these resources from www.microsoft.com.

3. Install the latest version of the firmware for the HBA. You can find the latest version of the firmware for the HBA at the HBA vendor website.



NOTE The remaining steps are general steps to obtain the HBA host port world wide name from the HBA BIOS utility. If you have installed the host context agent on all of your hosts, you do not need to perform these steps. If you are performing these steps, the actual prompts and screens vary depending on the vendor that provides the HBA. Also, some HBAs have software utilities that you can use to obtain the world wide name for the port instead of using the BIOS utility.

4. Reboot or start your host.
5. While your host is booting, look for the prompt to access the HBA BIOS utility.
6. Select each HBA to view its HBA host port world wide name.
7. Record the following information for each host and for each HBA connected to the storage array:
 - The name of each host
 - The HBAs in each host
 - The HBA host port world wide name of each port on the HBA

The following table shows examples of the host and HBA information that you must record.

Examples of HBA Host Port World Wide Names

| Host Name | Associated HBAs | HBA Host Port World Wide Name |
|----------------|---------------------------------|--|
| ICTENGINEERING | Vendor x, Model y (dual port) | 37:38:39:30:31:32:33:32 37:38:39:30:31:32:33:33 |
| | Vendor a, Model y (dual port) | 42:38:39:30:31:32:33:42 42:38:39:30:31:32:33:44 |
| ICTFINANCE | Vendor a, Model b (single port) | 57:38:39:30:31:32:33:52 |
| | Vendor x, Model b (single port) | 57:38:39:30:31:32:33:53 |

Step 4 – Installing the CDE2600 Controller-Drive Tray

Things to Know – General Installation

The power supplies meet standard voltage requirements for both domestic and worldwide operation.

NOTE Make sure that the combined power requirements of your trays do not exceed the power capacity of your cabinet.

Steps to Install – CDE2600-60 Controller-Drive Tray

You can install the high-density, 6-Gb SAS SBB 2.0-compliant CDE2600-60 controller-drive tray into an industry-standard cabinet, provided it has a depth of 100 cm (40 in.):

A minimum depth of 76 cm (30 in.) between the front EIA support rails and the rear EIA support rails is required.

NOTE If you are mounting the CDE2600-60 controller-drive tray in a cabinet with square holes, use the eight shoulder washers in the rail kit to align the screws in the holes (see [step 4](#) through [step 7](#)).

1. Make sure that the cabinet is in the final location. Make sure that you meet the clearance requirements shown in the following figure.

Controller-Drive Tray Airflow and Clearance Requirements

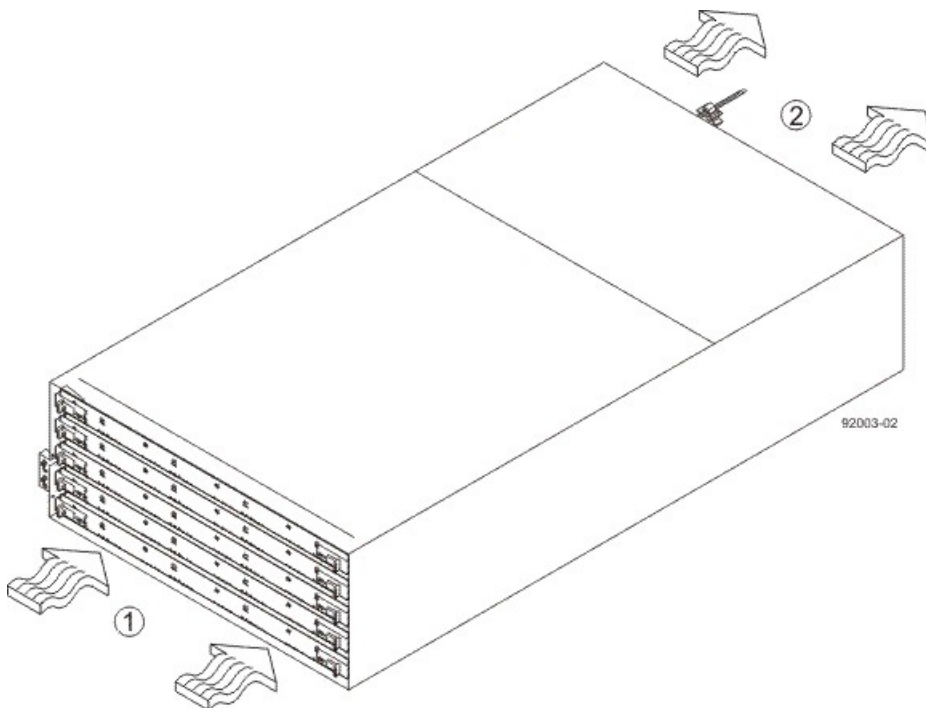

1. 81 cm (32 in.) clearance in front of the cabinet
2. 61 cm (24 in.) clearance behind the cabinet

NOTE Fans pull air through the controller-drive tray from front to back across the drives.

2. Lower the feet on the cabinet to keep the cabinet from moving.

 **WARNING (W09) Risk of bodily injury –**



>35 kg (70.5 lbs)

Three persons are required to safely lift the component.

 **WARNING (W15) Risk of bodily injury –** An empty tray weighs approximately 56.7 kg (125 lb). Three persons are required to safely move an empty tray. If the tray is populated with components, a mechanized lift is required to safely move the tray.

3. With the help of at least two other persons, remove the drive tray and all of the contents from the shipping carton, using the four controller-drive tray handles (two to a side) as shown in the figure " [Figure 2](#)". Set the drive tray aside.

CDE2600-60 Controller-Drive Tray with Controller-Drive Tray Handles (Two on Each Side)

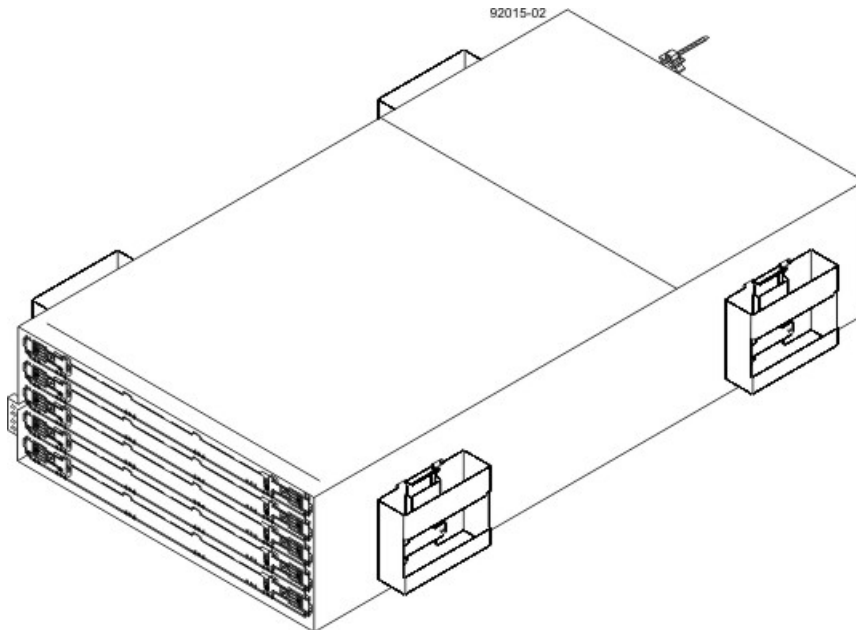

4. Position the mounting rails in the cabinet.

Positioning the Mounting Rails in the Cabinet

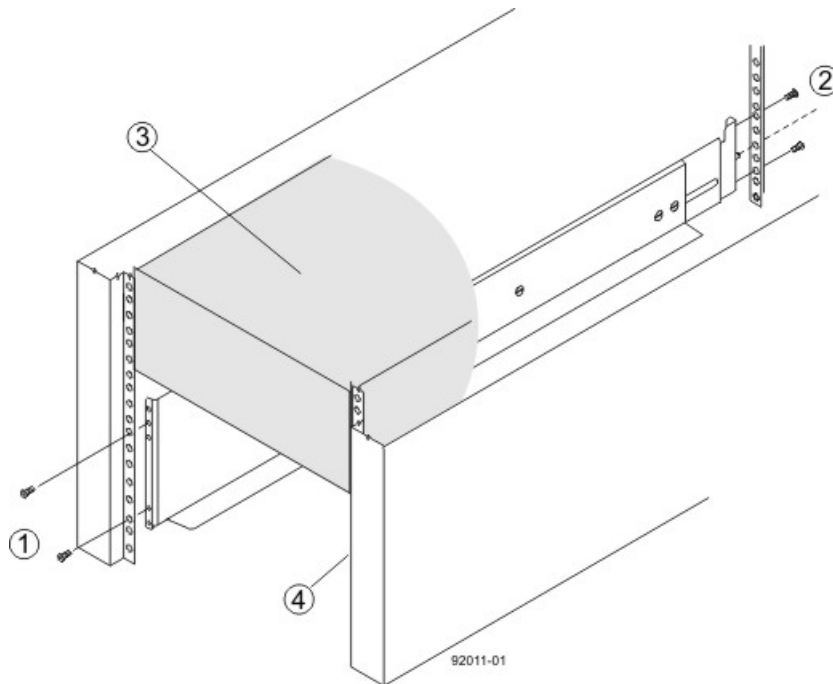

1. Screws for Securing the Mounting Rail to the Cabinet (Front)
 2. Screws for Securing the Mounting Rail to the Cabinet (Rear)
 3. Existing Tray
 4. Industry Standard Cabinet
- If you are installing the mounting rails above an existing tray, position the mounting rails directly above the controller-drive tray.
 - If you are installing the mounting rails below an existing tray, allow 17.8-cm (7-in.) vertical clearance for a CDE2600-60 controller-drive tray.
5. To attach the mounting rails to the cabinet, do one of the following:
 - If you are using the long fixed size mounting rails, go to [step 6](#).
 - If you are using the shorter adjustable mounting rails, go to [step 7](#).
 6. To attach the long mounting rails to the cabinet, perform these substeps:
 - a. Make sure that the adjustment screws on the mounting rail are loose so that the mounting rail can extend or contract as needed.

Attaching the Long Mounting Rails to the Cabinet

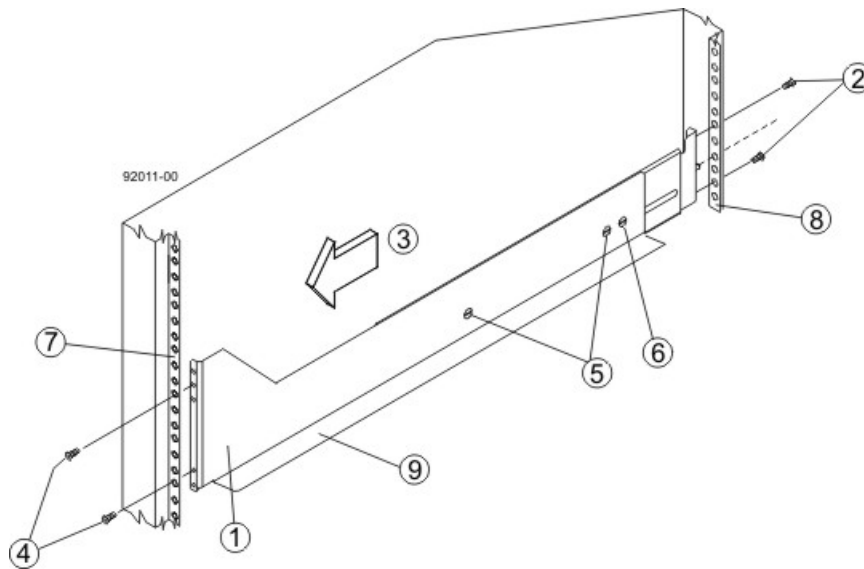

1. Front of the Mounting Rail
 2. Two M4 Screws for the Rear EIA Support Rail
 3. Front of the Cabinet
 4. Two M5 Screws for the Front EIA Support Rail
 5. Adjustable Rail Tightening Screws
 6. Rear Hold-Down Screw
 7. Cabinet Mounting Holes on the Front EIA Support Rail
 8. Cabinet Mounting Holes on the Rear EIA Support Rail
 9. Mounting Rail Lip
- b. Remove the rear hold-down screw. It protrudes from the inside of the rail and prevents you from sliding the drive tray onto the rails.
 - c. Place the mounting rail inside the cabinet, and extend the mounting rail until the flanges on the mounting rail touch the inside of the cabinet.
 - d. Insert one M5 screw through the front of the cabinet, and screw it into the top captured nut in the mounting rail.
 - e. Insert two M5 screws through the rear of the cabinet, and screw them into the captured nuts in the rear flange in the mounting rail.
 - f. Tighten the adjustment screws on the mounting rail.
 - g. Repeat substep a through substep f to install the second mounting rail.
 - h. Insert one M5 screw through the front of the mounting rail. You use this screw to attach the controller-drive tray to the cabinet.
7. To attach the shorter, adjustable size mounting rails to the cabinet, perform these sets of substeps:

Short Adjustable Mounting Rail -- Left Side

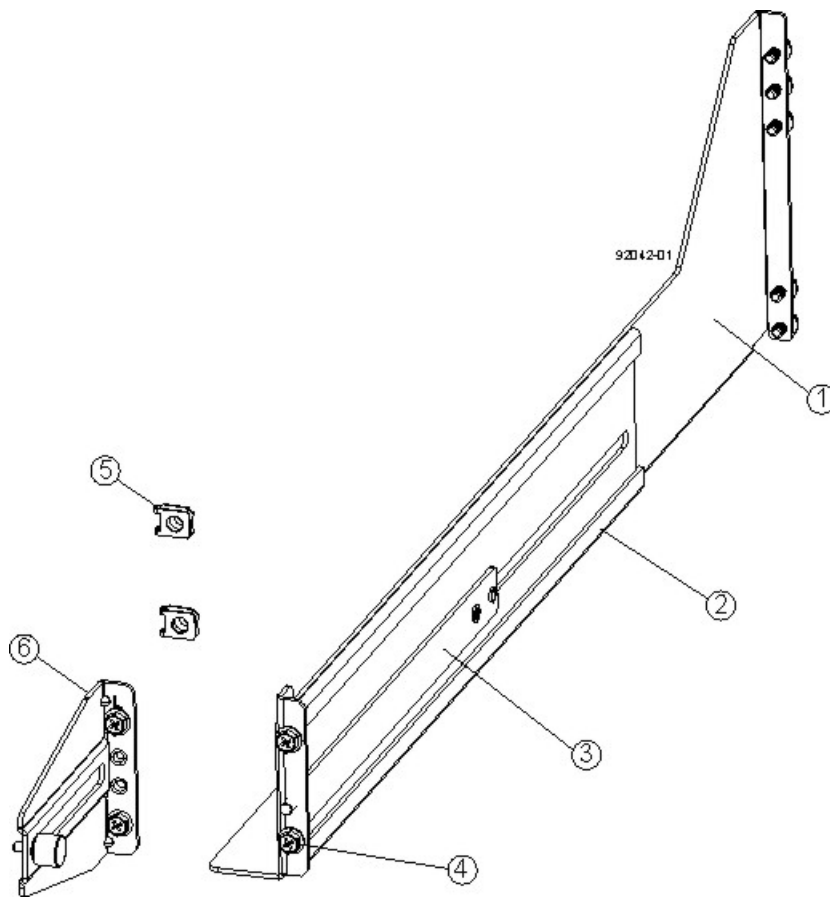

1. Front of the Mounting Rail
2. Rear of the Mounting Rail
3. Rail Fix Bar
4. Two M5 Screws for the Front EIA Support Rail
5. Two Clips for the Front EIA Support Rail
6. Rear Bracket

- a. Make sure that the adjustment screws on the mounting rail are loose so that the mounting rail can extend or contract as needed (see the figure [Figure 5](#)).
- b. Place the mounting rail inside the cabinet, and extend the mounting rail until the flanges on the mounting rail touch the inside of the cabinet (see the figure [Figure 6](#)).
- c. Insert one M5 screw through the front of the cabinet, and screw it into the top captured nut in the mounting rail.
- d. Insert two M4 screws through the rear of the cabinet, and screw them into the captured nuts in the rear flange in the mounting rail.
- e. Tighten the adjustment screws on the mounting rail.
- f. Repeat substep a through substep f to install the second mounting rail.
- g. Insert one M5 screw through the front of the mounting rail. This screw will attach the drive tray to the cabinet.

Short Adjustable Mounting Rail Attached to the Cabinet

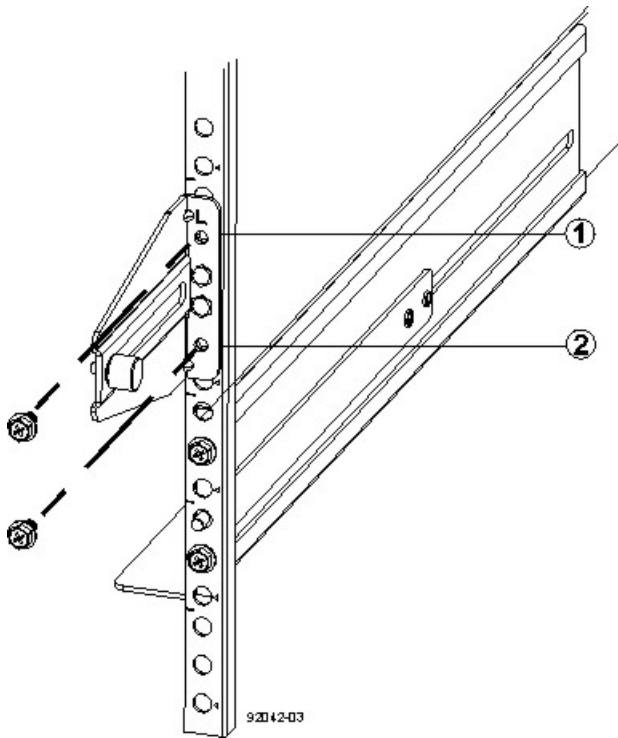

1. Top Cabinet Mounting Hole on the Rear EIA Support Rail
2. Bottom Cabinet Mounting Hole on the Rear EIA Support Rail

8. Remove the bezel from the front of the drive tray.



WARNING (W15) Risk of bodily injury – An empty tray weighs approximately 56.7 kg (125 lb). Three persons are required to safely move an empty tray. If the tray is populated with components, a mechanized lift is required to safely move the tray.

9. With the help of at least two other persons, slide the rear of the controller-drive tray onto the mounting rails. The controller-drive tray is correctly aligned when the mounting holes on the front flanges of the controller-drive tray align with the mounting holes on the front of the mounting rails.



WARNING (W15) Risk of bodily injury – An empty tray weighs approximately 56.7 kg (125 lb). Three persons are required to safely move an empty tray. If the tray is populated with components, a mechanized lift is required to safely move the tray.

10. After the controller-drive tray is correctly aligned, remove the enclosure lift handles as shown in the figure [Figure 7](#):

- a. Use your thumb to unlatch and remove the rear enclosure lift handles (two to a side).
- b. Use the front enclosure lift handles to slide the drive tray all the way into the cabinet.
- c. Once the drive tray is securely in the cabinet, use your thumb to unlatch and remove the front enclosure lift handles (two to a side).

Removing an Enclosure Lift Handle from the Controller-Drive Tray

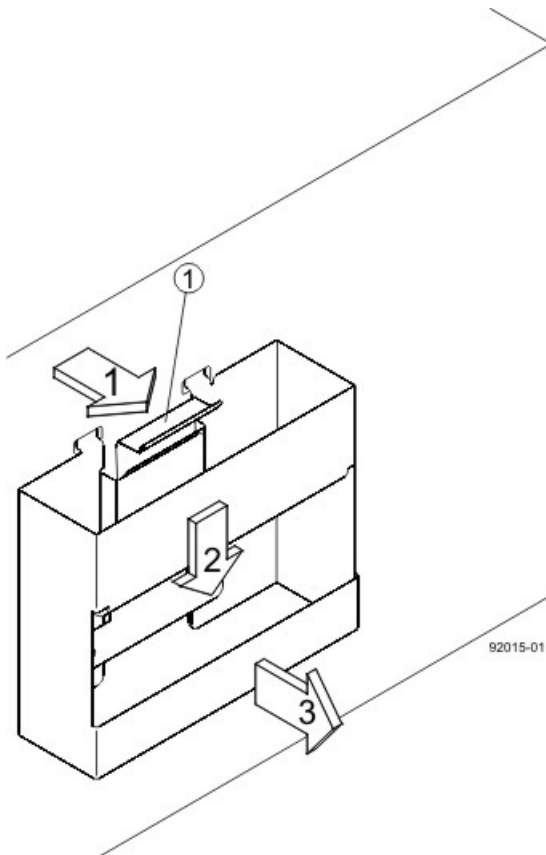

1. Pull the thumb latch away from the controller-drive tray to detach the hook.
 2. Shift the handle down to release the other four hooks.
 3. Move the handle away from the drive tray.
11. Secure the front of the controller-drive tray to the cabinet. Use the four screws to attach the flange on each side of the front of the controller-drive tray to the mounting rails.
- a. Insert two M5 screws through the bottom holes of a flange on the controller-drive tray so that the screws go through the EIA support rail and engage the bottom captured nuts in the mounting rail. Tighten the screws.
 - b. Repeat substep a for the second flange.

Attaching the Front of the Controller-Drive Tray

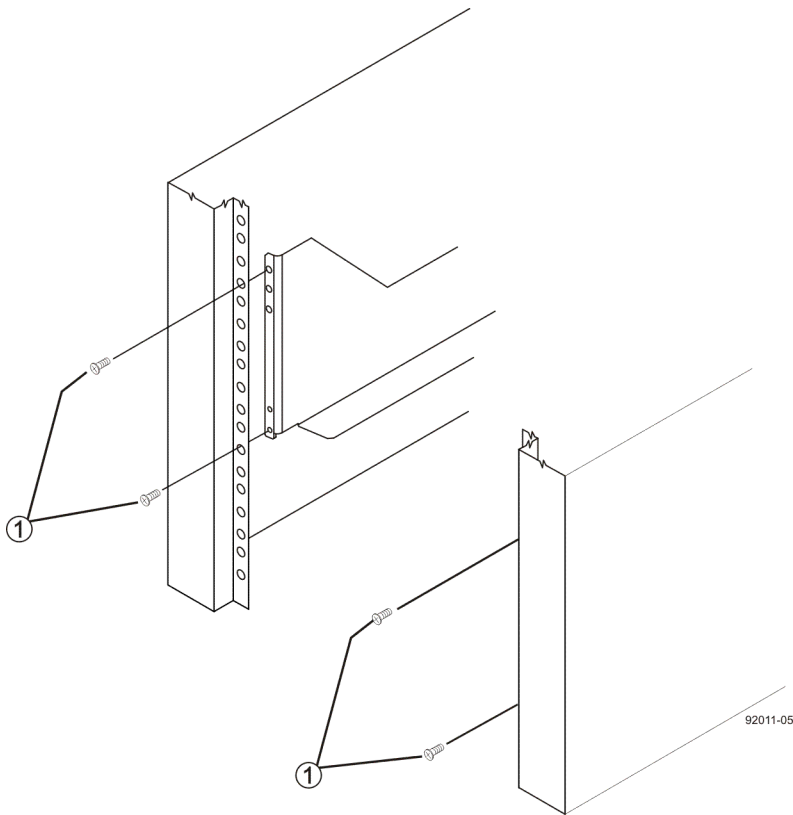

1. Four Screws for Securing the Front of the Controller-Drive Tray
12. Remove the fan canister from the drive tray by pressing on the tab holding the fan canister handle in place, and then pulling the fan canister toward you.

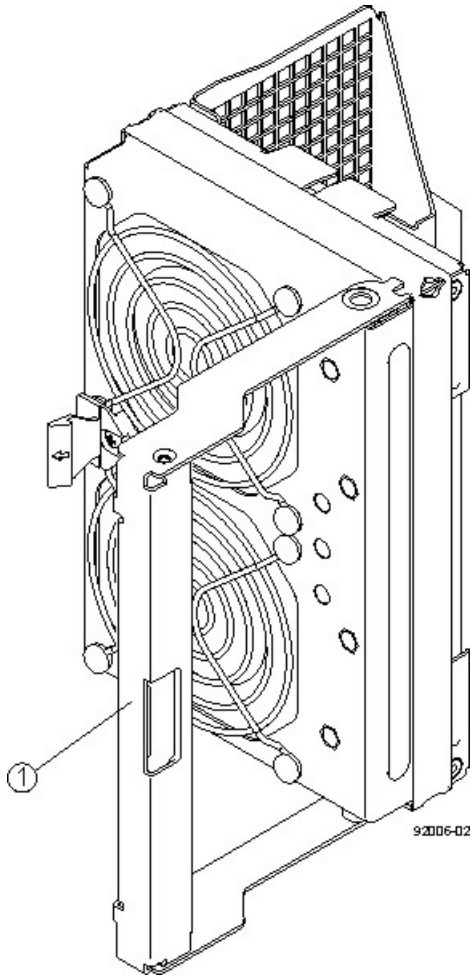

1. Fan Canister Handle

13. Use the fan canister handle to pull the fan canister out of the drive tray.

14. Secure the side of the controller-drive tray to the mounting rails by performing these substeps:

Securing the Controller-Drive Tray to the Rails

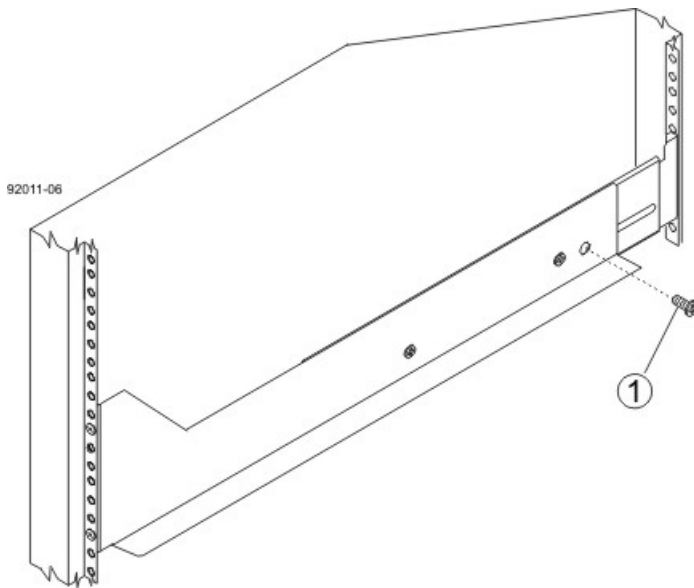

1. 10-32 Screw

- a. Insert a 10-32 screw through the side sheet metal of the controller-drive tray into the captured nut on the side of the mounting rail. Tighten the screws.
- b. Repeat substep a for the other side.



NOTE After the controller-drive tray is installed, there should be seven screws on each side (right and left) of the cabinet.



NOTE Make sure that each drive drawer in the controller-drive tray is securely fastened to ensure proper air flow to the drives.

Controller-Drive Tray Installed in the Cabinet

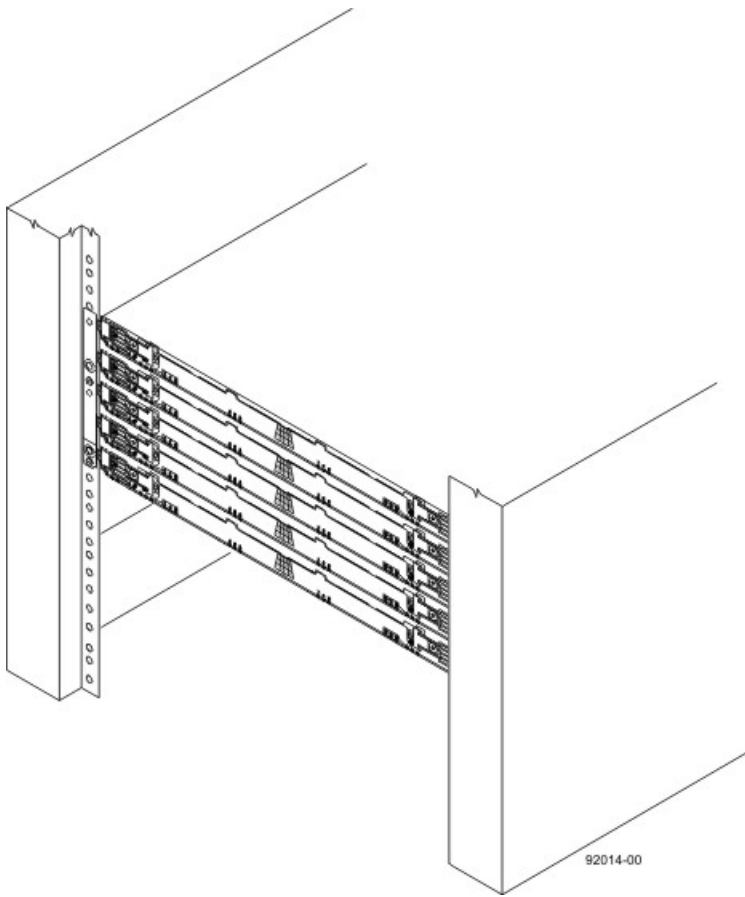

15. Slide the fan canister all the way back into the drive tray until the tab on the fan canister latches.
16. Attach the bezel onto the front of the controller-drive tray.

Step 5 – Connecting the CDE2600 Controller-Drive Tray to the Hosts

Key Terms

direct topology

A topology that does not use a switch.

switch topology

A topology that uses a switch.

topology

The logical layout of the components of a computer system or network and their interconnections. Topology deals with questions of what components are directly connected to other components from the standpoint of being able to communicate. It does not deal with questions of physical location of components or interconnecting cables. (The Dictionary of Storage Networking Terminology)

Things to Know – Host Channels on the CDE2600-60 Controller-Drive Tray



ATTENTION Possible hardware damage – To prevent electrostatic discharge damage to the tray, use proper antistatic protection when you handle tray components.

- Each controller has from two to six host ports.
- Two of the host ports are standard and support 6-Gb/s SAS data rates.
- Two to four of the host ports are optional, and, if present, are located on a host interface card (HIC). The following types of HICs are supported:



NOTE In configurations where a HIC does not exist, the space is covered with a blank faceplate.

- Two SAS connectors at 6-Gb/s
- Four iSCSI connectors at 1-Gb/s
- Two iSCSI connectors at 10-Gb/s
- Four FC connectors at 8-Gb/s

Host Channels on the CDE2600-60 Controllers – Rear View

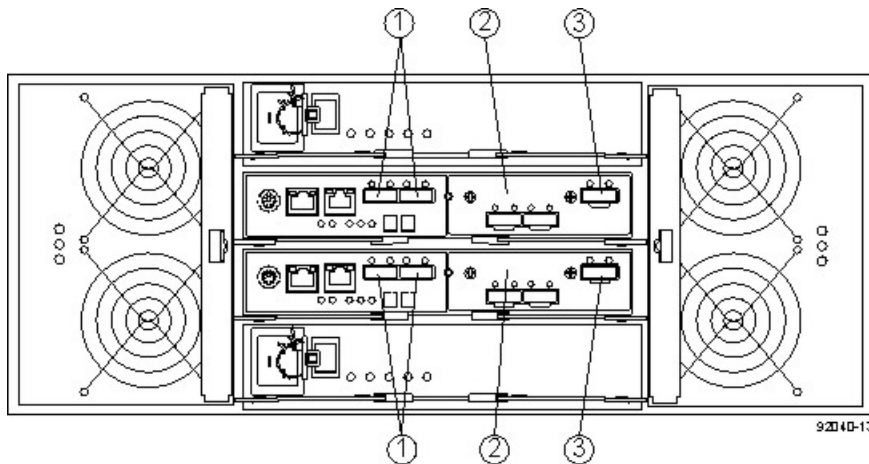

1. Standard Host Connectors
2. Host Interface Card (HIC) Connectors (SAS in this Example)
3. SAS Expansion Connector



WARNING (W03) Risk of exposure to laser radiation – Do not disassemble or remove any part of a Small Form-factor Pluggable (SFP) transceiver because you might be exposed to laser radiation.

Procedure – Connecting Host Cables on a CDE2600-60 Controller-Drive Tray



IMPORTANT Make sure that you have installed the HBAs. Refer to the documentation for the HBAs for information about how to install the HBA and how to use the supplied configuration utilities.

The type of HICs (SAS, FC, or iSCSI) must match the type of the host bus adapters (HBAs) or network interface cards (for iSCSI only) to which you connect them.

See the examples in the following section for example cabling patterns.

1. Perform one of these actions:
 - **You are using an FC HIC** – Go to [step 2](#).
 - **You are using either a SAS or an iSCSI HIC** – Go to [step 4](#). Connections for both SAS and iSCSI use copper cables with RJ-45 connectors and do not require SFP transceivers.
2. Make sure that the appropriate type of SFP transceiver is inserted into the host channel.
3. If a black, plastic plug is in the SFP transceiver, remove it.
4. Perform one of these actions:
 - **You are using either a SAS or an iSCSI HIC** – Starting with the first host channel of each controller, plug one end of the cable into the host channel.
 - **You are using an FC HIC** – Starting with the first host channel of each controller, plug one end of the cable into the SFP transceiver in the host channel.

The cable is either an Ethernet cable with RJ-45 connectors for 1-Gb/s iSCSI or 6-Gb/s SAS connections, or a fiber-optic cable for FC connections.



IMPORTANT If Remote Volume Mirroring connections are required, do not connect a host to the highest numbered host channel.

Direct Topology – One Host Connected to a Single Controller

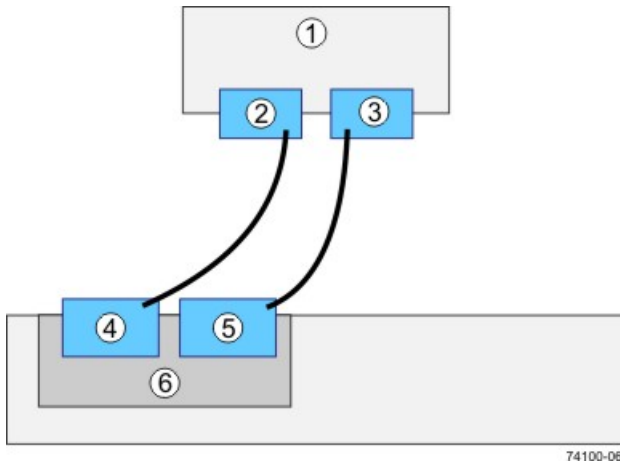

1. Host
2. HBA 1 or NIC 1
3. HBA 2 or NIC 2
4. Host Port 1
5. Host Port 2
6. Controller A

Direct Topology – Two Hosts Connected to a Single Controller

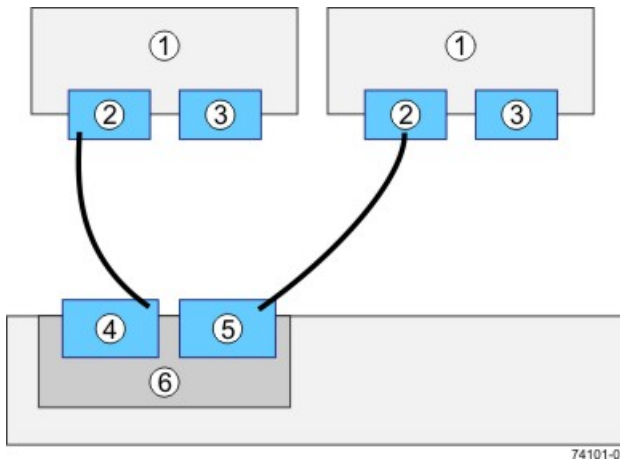

1. Host
2. HBA 1 or NIC 1
3. HBA 2 or NIC 2
4. Host Port 1
5. Host Port 2
6. Controller A

Switch Topology – Two Hosts Connected to a Single Controller Through a Switch

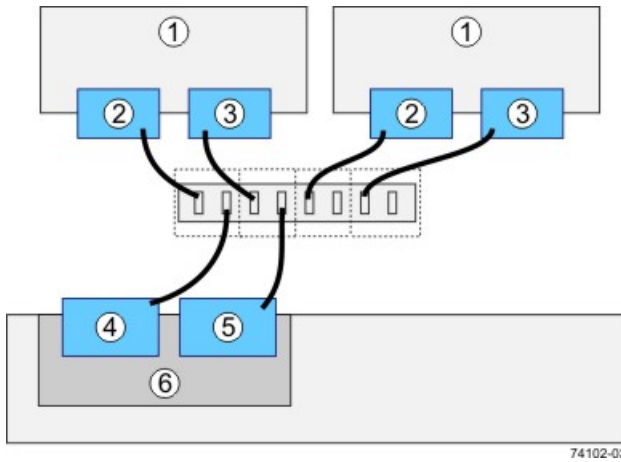

1. Host
2. HBA 1 or NIC 1
3. HBA 2 or NIC 2
4. Host Port 1
5. Host Port 2
6. Controller A

Direct Topology – One Host and a Dual Controller-Drive Tray

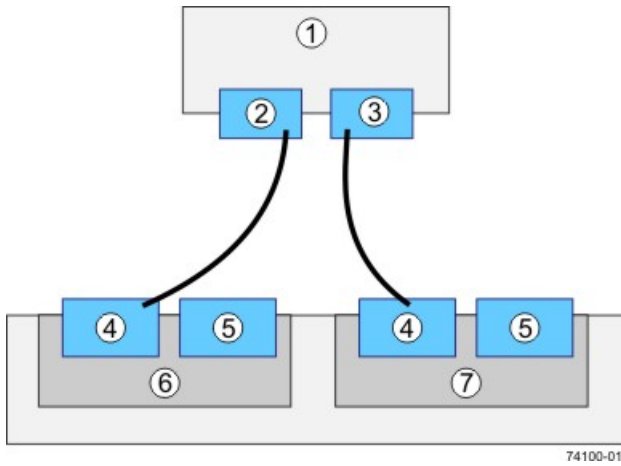

1. Host
2. HBA 1 or NIC 1
3. HBA 2 or NIC 2
4. Host Port 1
5. Host Port 2
6. Controller A
7. Controller B

Direct Topology – Two Hosts and a Dual Controller-Drive Tray for Maximum Redundancy

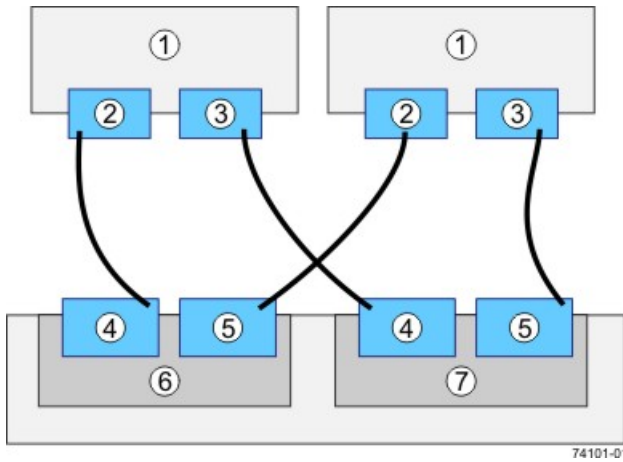

1. Hosts
2. HBA 1 or NIC 1
3. HBA 2 or NIC 2
4. Host Port 1
5. Host Port 2
6. Controller A
7. Controller B

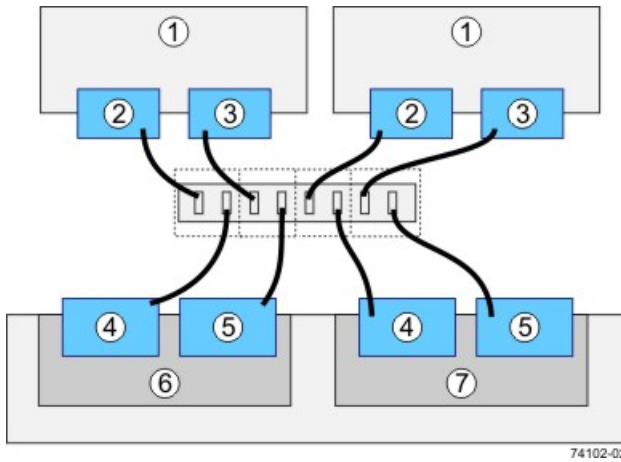
Mixed Topology – Two Hosts and a Dual Controller-Drive Tray

1. Hosts
2. HBA 1 or NIC 1
3. HBA 2 or NIC 2
4. Host Port 1
5. Host Port 2
6. Controller A
7. Controller B

Mixed Topology – Three Hosts and a Dual Controller-Drive Tray

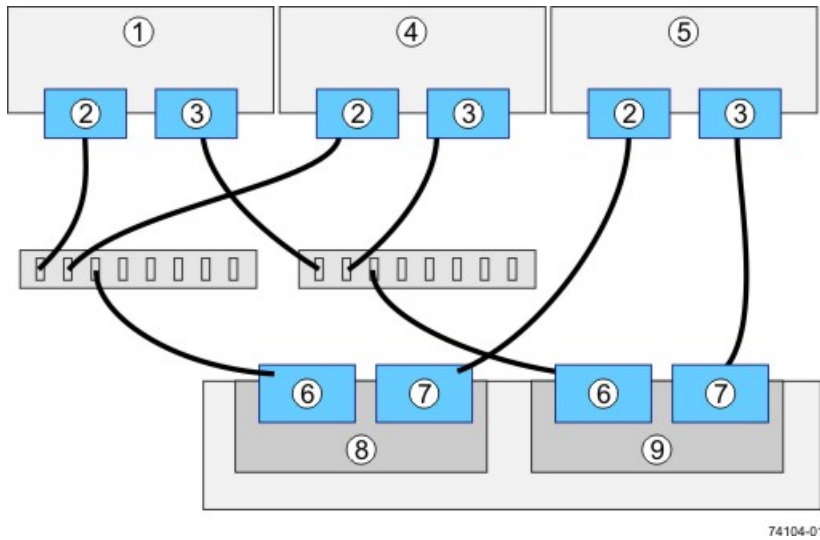

74104-01

1. Host 1
2. HBA 1 or NIC 1
3. HBA 2 or NIC 2
4. Host 2
5. Host 3
6. Host Port 1
7. Host Port 2
8. Controller A
9. Controller B

5. Plug the other end of the cable either into an HBA in the host (direct topology) or into a switch (fabric topology).



NOTE The SAS host interface does not support a switch topology.

6. Affix a label to each end of the cable with this information. A label is very important if you need to disconnect cables to service a controller. Include this information on the labels:
 - The host name and the HBA port (for direct topology)
 - The switch name and the port (for fabric topology)
 - The controller ID (for example, controller A)
 - The host channel ID (for example, host channel 1)

Example label abbreviation – Assume that a cable is connected between port 1 in HBA 1 of a host named Engineering and host channel 1 of controller A. A label abbreviation could be as follows.

Heng-HBA1/P1, CtA-Hch1

7. Repeat step 3 through step 6 for each controller and host channel that you intend to use.

Step 6 – Installing the Drive Trays for the CDE2600-60 Controller-Drive Tray Configurations

Things to Know – General Installation of Drive Trays with the CDE2600-60 Controller-Drive Tray



IMPORTANT If you are installing the drive tray in a cabinet with other trays, make sure that the combined power requirements of the drive tray and the other trays do not exceed the power capacity of your cabinet. For more information, refer to the SANtricity ES Storage Manager Installation DVD.

- Special site preparation is not required for any of these drive trays beyond what is normally found in a computer lab environment.
- The power supplies meet standard voltage requirements for both domestic and worldwide operation.
- Take these precautions:
 - Install the drive trays in locations within the cabinet that let you evenly distribute the drive trays around the controller-drive tray.
 - Keep as much weight as possible in the bottom half of the cabinet.



NOTE Refer to the *Storage System Site Preparation Guide* on the SANtricity ES Storage Manager Installation DVD for important considerations about cabinet installation.



WARNING (W15) Risk of bodily injury – An empty tray weighs approximately 56.7 kg (125 lb). Three persons are required to safely move an empty tray. If the tray is populated with components, a mechanized lift is required to safely move the tray.

Steps to Install – DE6600 Drive Tray

You can install the high-density, 6-Gb SAS SBB 2.0-compliant DE6600 drive tray into an Industry-standard cabinet, provided it has a depth of 100 cm (40 in.):

A minimum depth of 76 cm (30 in.) between the front EIA support rails and the rear EIA support rails is required.



NOTE If you are mounting the DE6600 drive tray in a cabinet with square holes, use the eight shoulder washers in the rail kit to align the screws in the holes (see [step 4](#) through [step 7](#)).

1. Make sure that the cabinet is in the final location. Make sure that you meet the clearance requirements shown in the following figure.

Drive Tray Airflow and Clearance Requirements

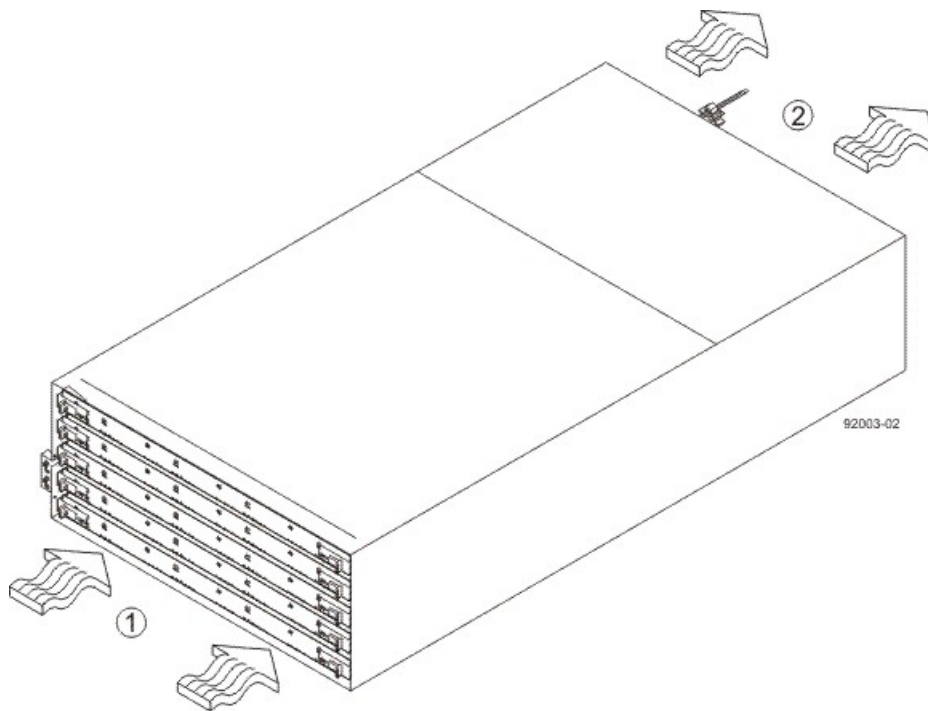

1. 81 cm (32 in.) clearance in front of the cabinet
2. 61 cm (24 in.) clearance behind the cabinet



NOTE Fans pull air through the drive tray from front to back across the drives.

2. Lower the feet on the cabinet to keep the cabinet from moving.



WARNING (W09) Risk of bodily injury –



>35 kg (70.5 lbs)

Three persons are required to safely lift the component.



WARNING (W15) Risk of bodily injury – An empty tray weighs approximately 56.7 kg (125 lb). Three persons are required to safely move an empty tray. If the tray is populated with components, a mechanized lift is required to safely move the tray.

3. With the help of at least two other persons, remove the drive tray and all of the contents from the shipping carton, using the four drive tray handles (two to a side) as shown in the following figure. Set the drive tray aside.

DE6600 Drive Tray with Drive Tray Handles (Two on Each Side)

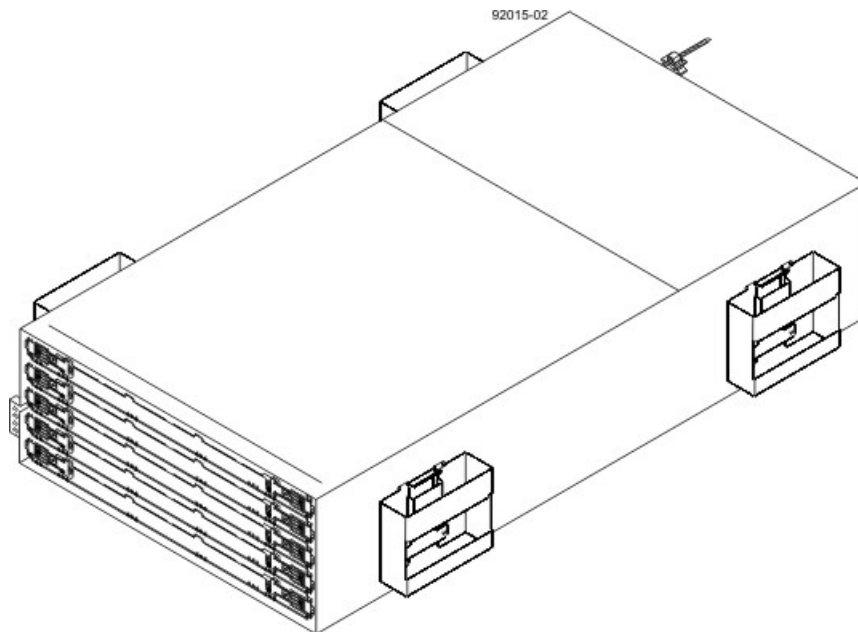

4. Position the mounting rails in the cabinet.

Positioning the Mounting Rails in the Cabinet

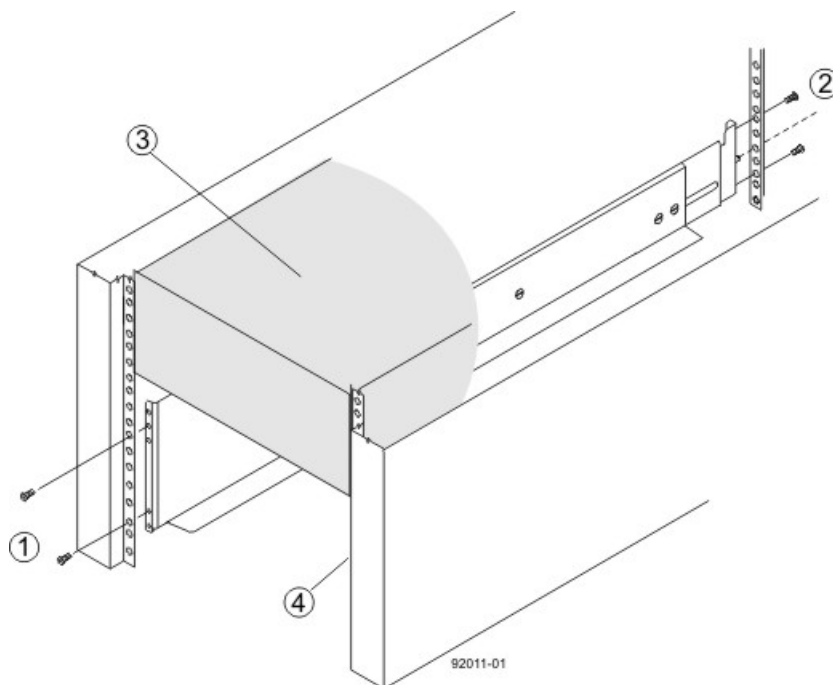

1. Screws for Securing the Mounting Rail to the Cabinet (Front)
 2. Screws for Securing the Mounting Rail to the Cabinet (Rear)
 3. Existing Tray
 4. Industry Standard Cabinet
- If you are installing the mounting rails above an existing tray, position the mounting rails directly above the tray.

- If you are installing the mounting rails below an existing tray, allow 17.8-cm (7-in.) vertical clearance for a DE6600 drive tray.
5. To attach the mounting rails to the cabinet, do one of the following:
 - If you are using the long fixed size mounting rails, go to [step 6](#).
 - If you are using the shorter adjustable mounting rails, go to [step 7](#).
 6. To attach the long mounting rails to the cabinet, perform these substeps:
 - a. Make sure that the adjustment screws on the mounting rail are loose so that the mounting rail can extend or contract as needed.

Attaching the Long Mounting Rails to the Cabinet

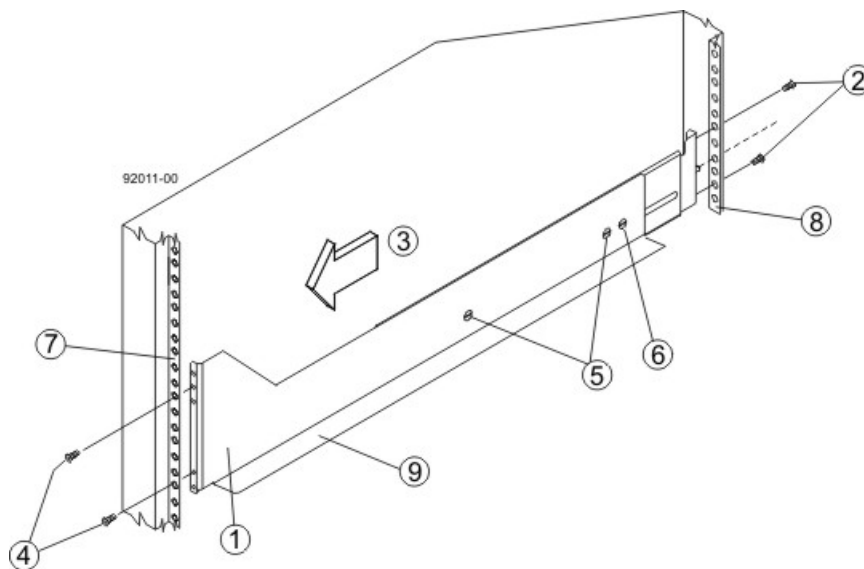

1. Front of the Mounting Rail
 2. Two M4 Screws for the Rear EIA Support Rail
 3. Front of the Cabinet
 4. Two M5 Screws for the Front EIA Support Rail
 5. Adjustable Rail Tightening Screws
 6. Rear Hold-Down Screw
 7. Cabinet Mounting Holes on the Front EIA Support Rail
 8. Cabinet Mounting Holes on the Rear EIA Support Rail
 9. Mounting Rail Lip
- b. Remove the rear hold-down screw. It protrudes from the inside of the rail and prevents you from sliding the drive tray onto the rails.
 - c. Place the mounting rail inside the cabinet, and extend the mounting rail until the flanges on the mounting rail touch the inside of the cabinet.
 - d. Insert one M5 screw through the front of the cabinet, and screw it into the top captured nut in the mounting rail.
 - e. Insert two M5 screws through the rear of the cabinet, and screw them into the captured nuts in the rear flange in the mounting rail.
 - f. Tighten the adjustment screws on the mounting rail.
 - g. Repeat substep a through substep f to install the second mounting rail.
 - h. Insert one M5 screw through the front of the mounting rail. You use this screw to attach the drive tray to the cabinet.

7. To attach the shorter, adjustable size mounting rails to the cabinet, perform these sets of substeps:

Short Adjustable Mounting Rail -- Left Side

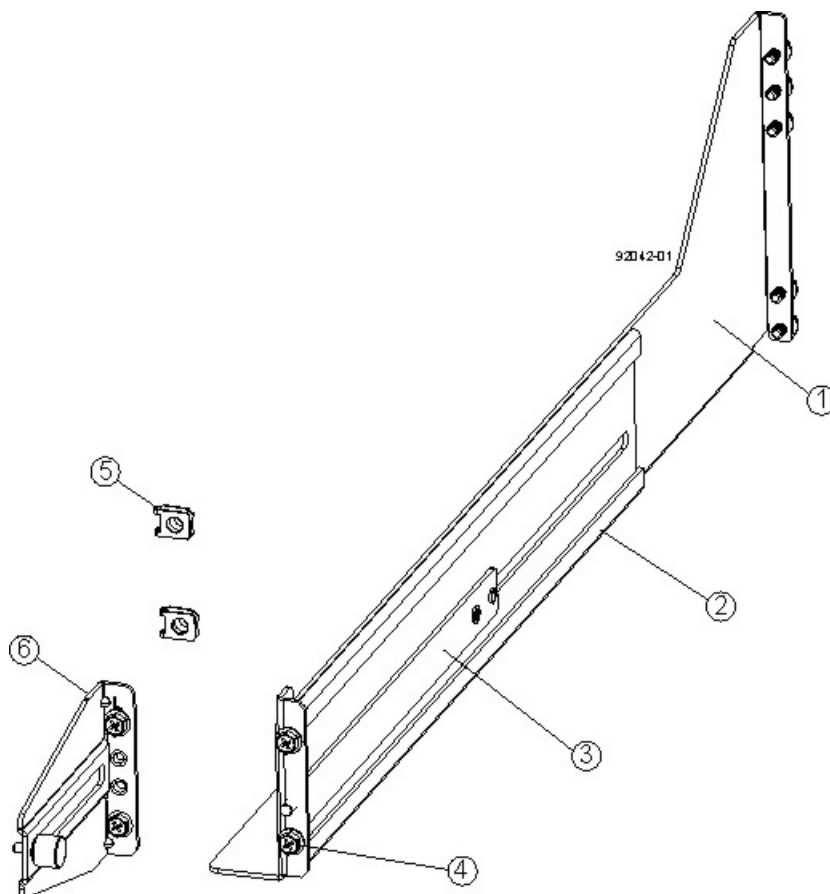

1. Front of the Mounting Rail
2. Rear of the Mounting Rail
3. Rail Fix Bar
4. Two M5 Screws for the Front EIA Support Rail
5. Two Clips for the Front EIA Support Rail
6. Rear Bracket

- a. Make sure that the adjustment screws on the mounting rail are loose so that the mounting rail can extend or contract as needed (see the figure [Figure 5](#)).
- b. Place the mounting rail inside the cabinet, and extend the mounting rail until the flanges on the mounting rail touch the inside of the cabinet (see the figure [Figure 6](#)).
- c. Insert one M5 screw through the front of the cabinet, and screw it into the top captured nut in the mounting rail.
- d. Insert two M5 screws through the rear of the cabinet, and screw them into the captured nuts in the rear flange in the mounting rail.
- e. Tighten the adjustment screws on the mounting rail.
- f. Repeat substep a through substep f to install the second mounting rail.
- g. Insert one M5 screw through the front of the mounting rail. This screw will attach the drive tray to the cabinet.

Short Adjustable Mounting Rail Attached to the Cabinet

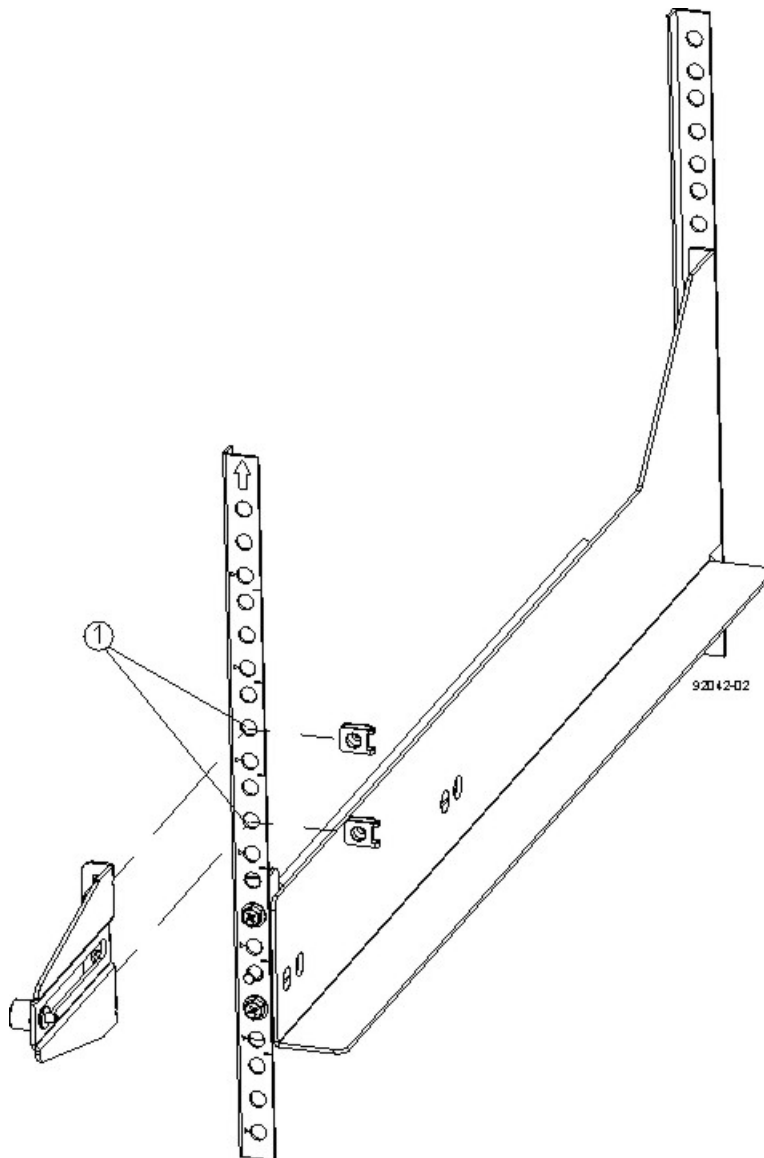

1. Cabinet Mounting Holes on the Front EIA Support Rail
8. Remove the bezel from the front of the drive tray.



WARNING (W09) Risk of bodily injury –



>35 kg (70.5 lbs)

Three persons are required to safely lift the component.

9. With the help of at least two other persons, slide the rear of the drive tray onto the mounting rails. The drive tray is correctly aligned when the mounting holes on the front flanges of the drive tray align with the mounting holes on the front of the mounting rails.

 **WARNING (W15) Risk of bodily injury** – An empty tray weighs approximately 56.7 kg (125 lb). Three persons are required to safely move an empty tray. If the tray is populated with components, a mechanized lift is required to safely move the tray.

10. After the controller-drive tray is correctly aligned, remove the enclosure lift handles as shown in the figure [Figure 7](#):

- a. Use your thumb to unlatch and remove the rear enclosure lift handles (two to a side).
- b. Use the front enclosure lift handles to slide the drive tray all the way into the cabinet.
- c. Once the drive tray is securely in the cabinet, use your thumb to unlatch and remove the front enclosure lift handles (two to a side).

Removing an Enclosure Lift Handle from the Drive Tray

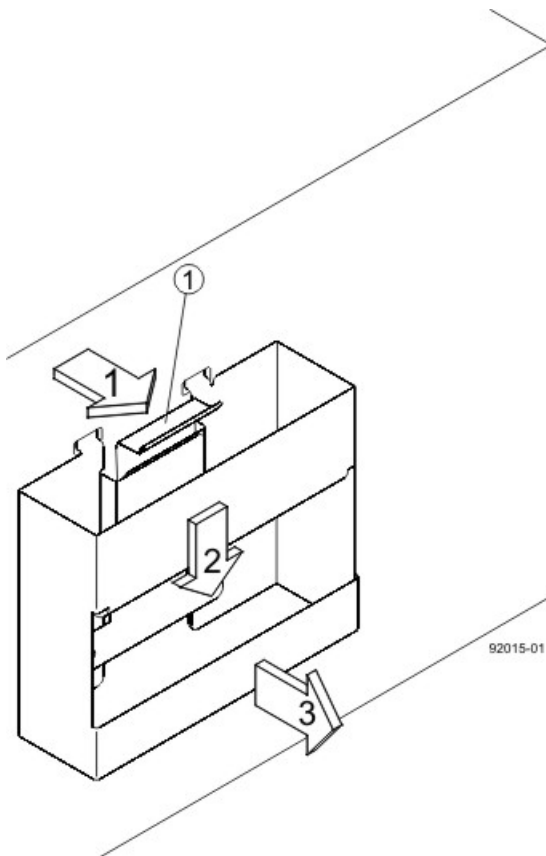

1. Pull the thumb latch away from the drive tray to detach the hook.
2. Shift the handle down to release the other four hooks.
3. Move the handle away from the drive tray.

11. Secure the front of the drive tray to the cabinet. Use the four screws to attach the flange on each side of the front of the drive tray to the mounting rails.
 - a. Insert two M5 screws through the bottom holes of a flange on the drive tray so that the screws go through the EIA support rail and engage the bottom captured nuts in the mounting rail. Tighten the screws.
 - b. Repeat substep a for the second flange.

Attaching the Front of the Drive Tray

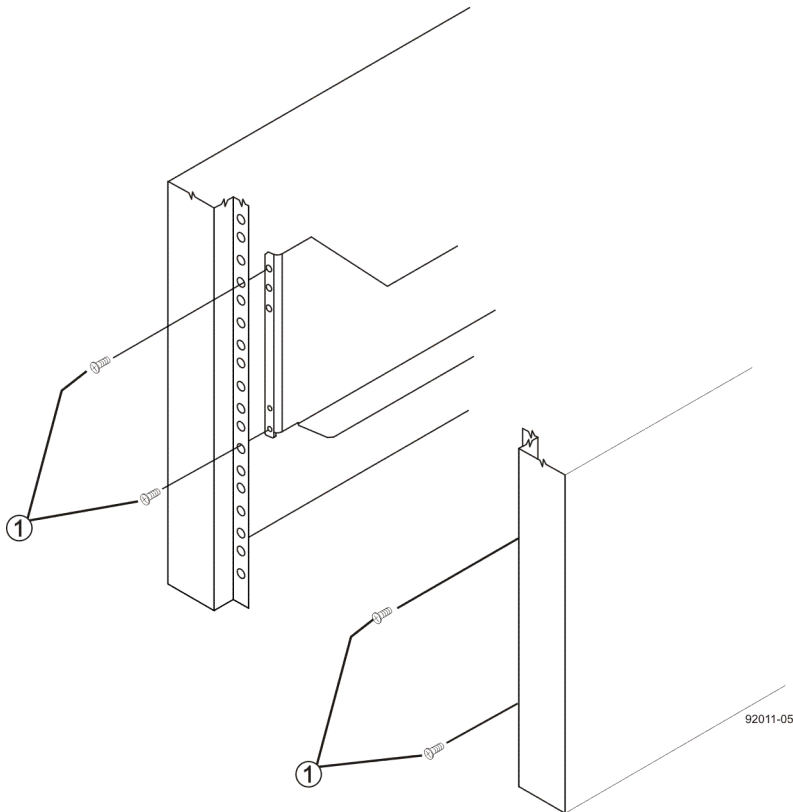

1. Four Screws for Securing the Front of the Drive Tray
12. Remove the fan canister from the drive tray by pressing on the tab holding the fan canister handle in place, and then pulling the fan canister toward you.

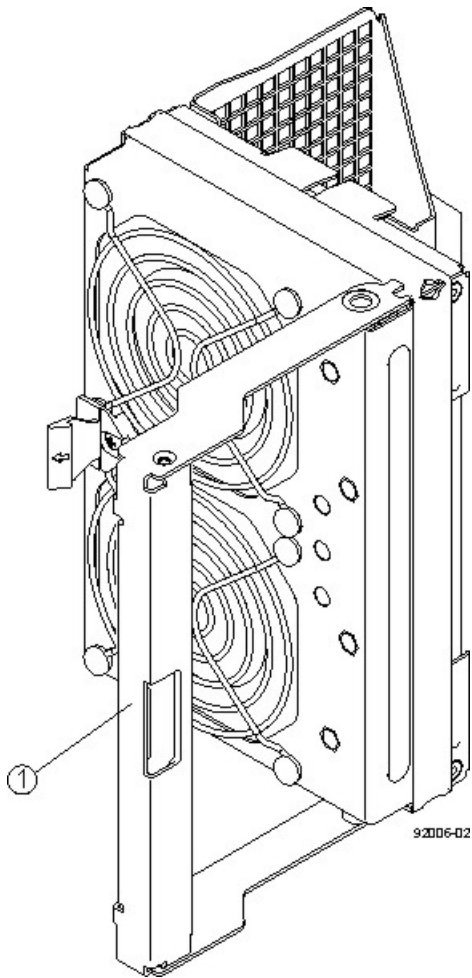

1. Fan Canister Handle

13. Use the fan canister handle to pull the fan canister out of the drive tray.

14. Secure the side of the drive tray to the mounting rails by performing these substeps:

Securing the Drive Tray to the Rails

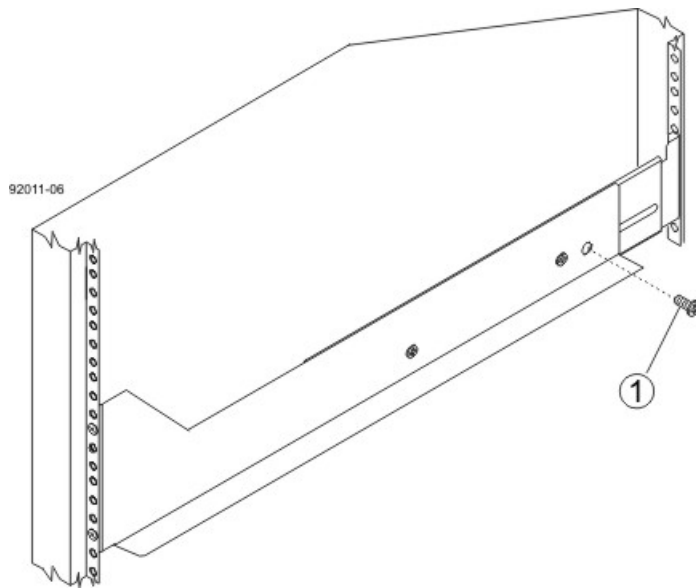

1. 10-32 Screw

- a. Insert a 10-32 screw through the side sheet metal of the drive tray into the captured nut on the side of the mounting rail. Tighten the screws.
- b. Repeat substep a for the other side.



NOTE After the drive tray is installed, there should be seven screws on each side (right and left) of the cabinet.



NOTE Make sure that each drive drawer in the drive tray is securely fastened to ensure proper air flow to the drives.

Drive Tray Installed in the Cabinet

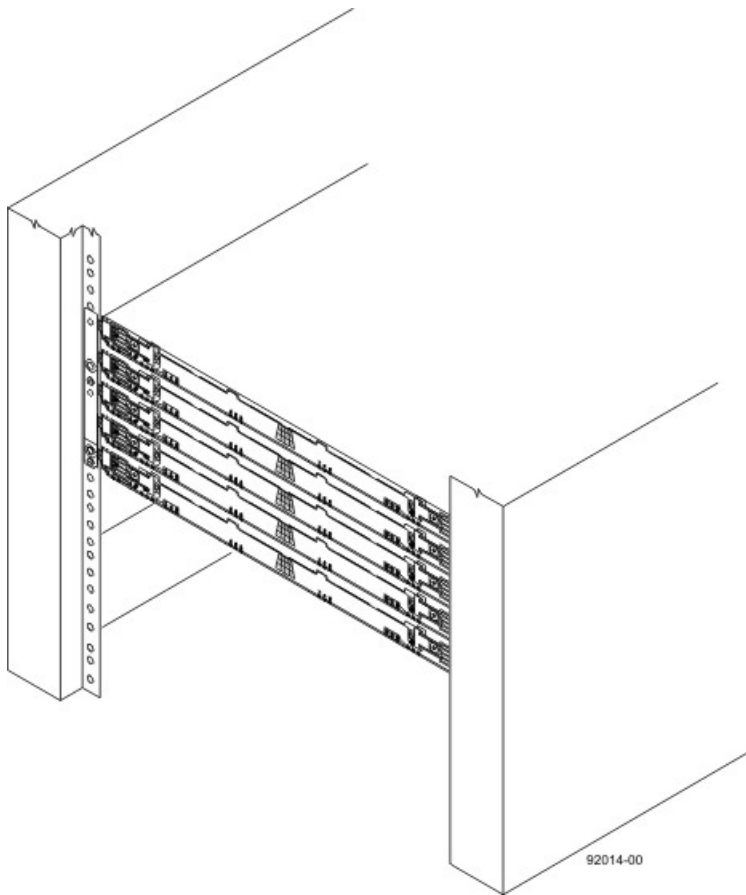

15. Slide the fan canister all the way back into the drive tray until the tab on the fan canister latches.
16. Attach the bezel onto the front of the drive tray.

Steps to Install – Drives on the DE6600 Drive Tray

The DE6600 drive tray is shipped with the drive drawers installed, but the drives are not installed. Follow the steps in this procedure to install the drives.

ATTENTION Risk of equipment malfunction – To avoid exceeding the functional and environmental limits, install only drives that have been provided or approved by the original manufacturer. Drives might be shipped but not installed. System integrators, resellers, system administrators, or users can install the drives.

IMPORTANT The installation order within each drawer is from left to right in rows. Slots 1, 4, 7 and 10 must have a drive installed in these locations to make sure there is sufficient air flow to the drives. To verify these slots, consult the overlay on the front of each of the five drive drawers. Make sure the four drives in each row are adjacent to each other. The long edge of each drive should touch the drive next to it. To maintain a uniform airflow across all drive drawers, the drive tray must be configured with a minimum of 20 drives, with four drives in the front row of each of the five drive drawers.

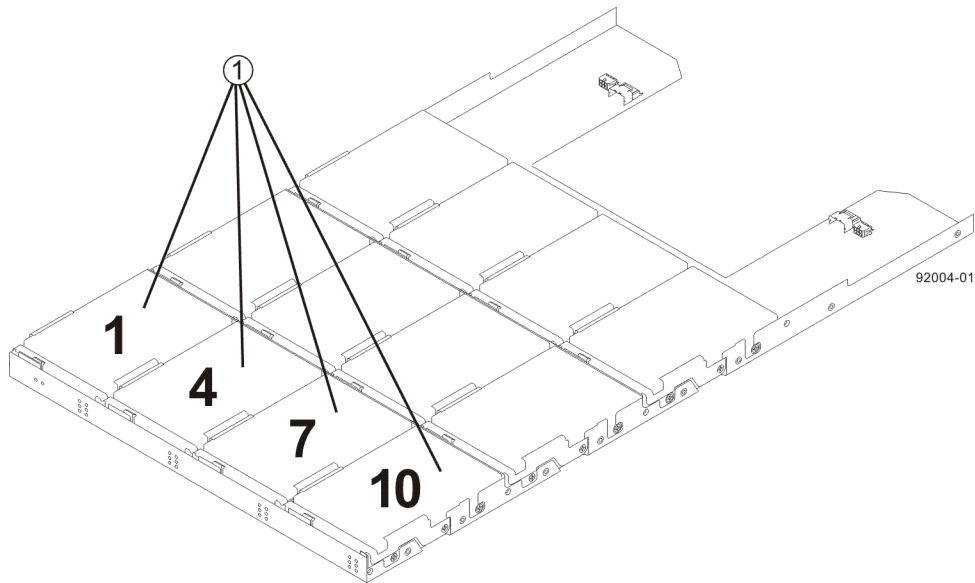

1. DE6600 Drive Tray with Slots 1, 4, 7, and 10



ATTENTION Risk of equipment malfunction – For the DE6600 drive tray, you can only replace one canister or drive at a time. Refer to the “Replacing a Drive on the DE6600 Drive tray” instructions on the Software and Documentation DVD, and make sure you have the replacement drive in hand before starting the task.

1. Beginning with the top drawer in the drive tray, release the levers on each side of the drawer by pulling both towards the center.

Levers on the Drive Drawer

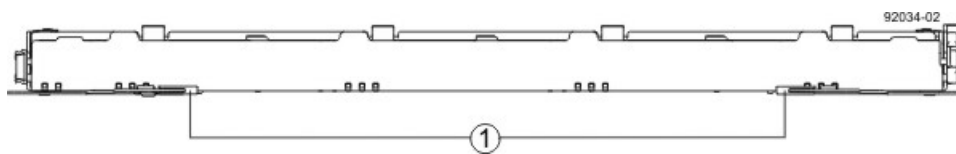

2. Pull on the extended levers to pull the drive drawer out to its full extension without removing it from the drive tray.
3. Starting with the first drive, raise the drive handle to the vertical position (** UNDEFINED CROSS-REF FORMAT [FigureOrTableNum] **).

Raised Drive Handle

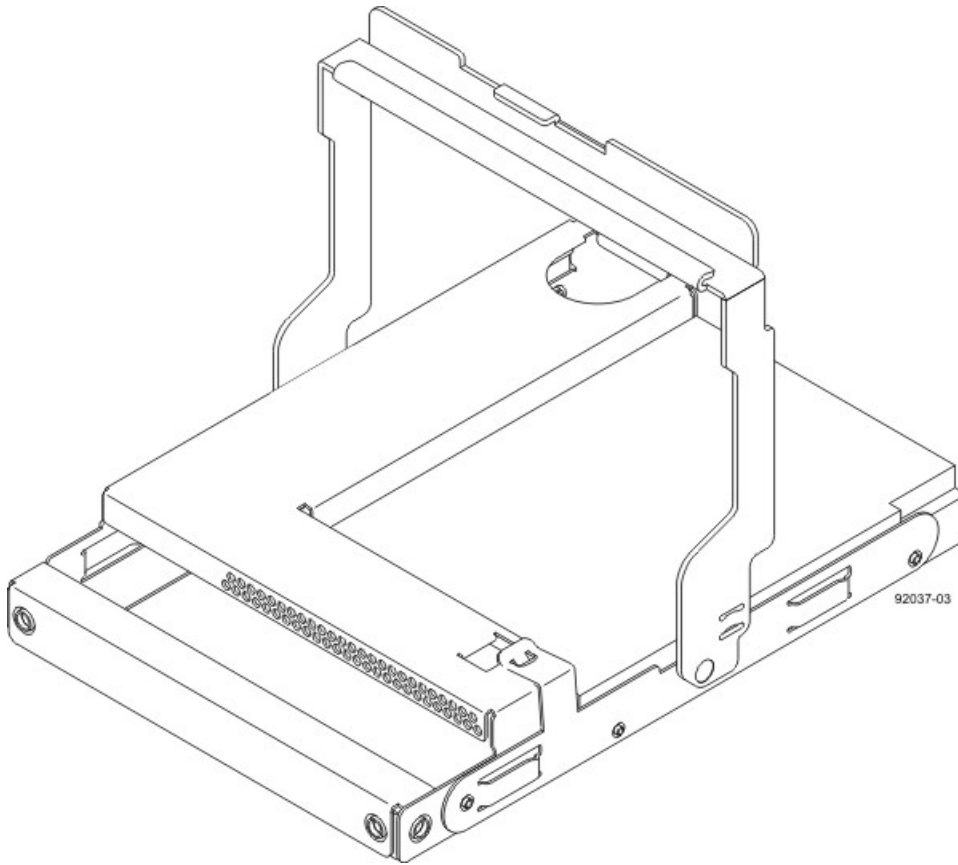

4. Align the two raised buttons on each side over the matching gap in the drive channel on the drawer.

Side View of Drive with Raised Handle

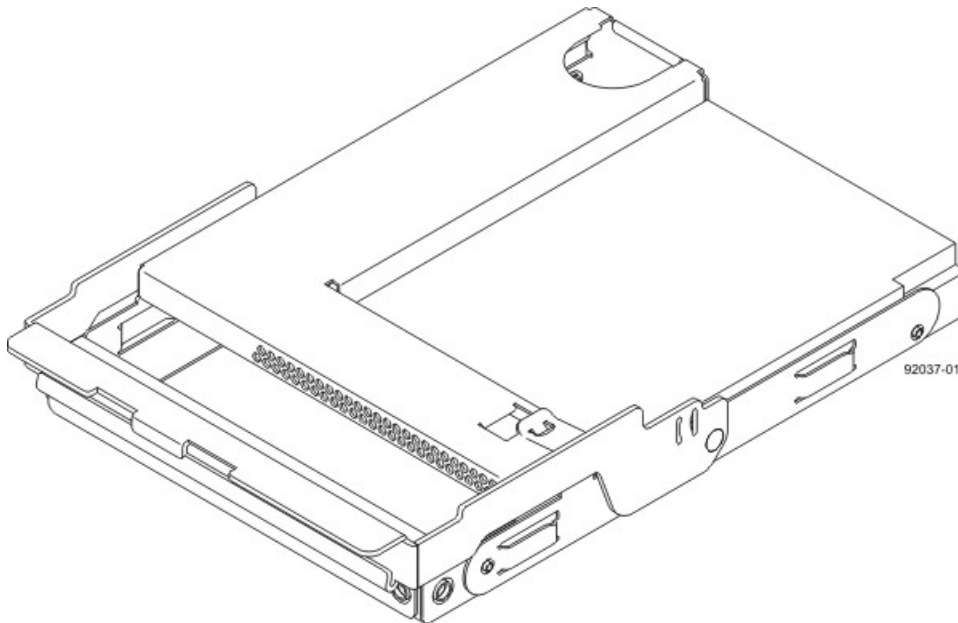

1. Raised Buttons

- Lower the drive straight down, and then rotate the drive handle down until the drive snaps into place under the drive release lever.

Drive Release Lever Locked by the Drive Handle

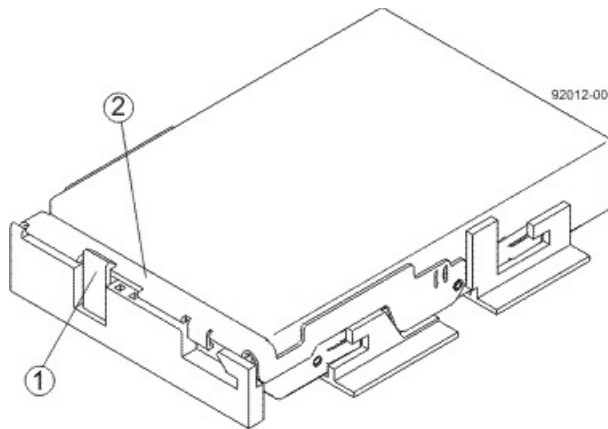

- Drive Release Lever
- Drive Handle

- Install the other drives in rows from left to right until the drive drawer is fully populated.

Fully-Populated Drive Drawer

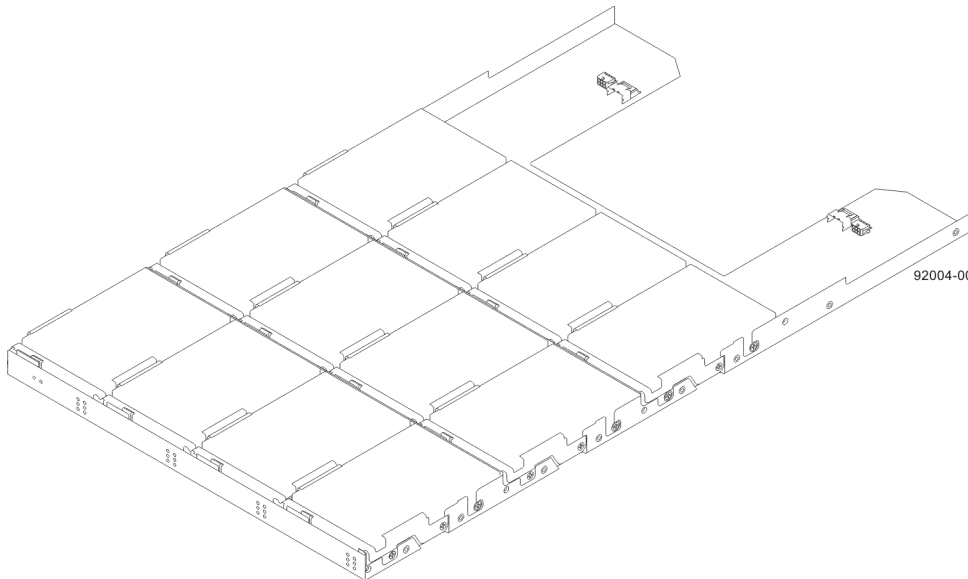

- Push the drive drawer all the way back into the drive tray, closing the levers on each side of the drive drawer.



ATTENTION Risk of equipment malfunction – Make sure you push both levers to each side so the drive drawer is completely closed. The drive drawer must be completely closed to prevent excess airflow, which has the potential to damage the drives.

- Continue onto the next drive drawer, repeating step 1 through step 7 for each drive drawer in the configuration.

Step 7 – Connecting the CDE2600-60 Controller-Drive Tray to the Drive Trays

Key Terms

drive channel

The path for the transfer of data between the controllers and the drives in the storage array.

Things to Know – CDE2600-60 Controller-Drive Tray

NOTE On the CDE2600-60 controller-drive tray, each controller has a pair of levers with handles for removing the controller from the controller-drive tray. One of these handles on each controller is located next to a host connector. The close spacing between the handle and the host connector might make it difficult to remove a cable that is attached to the host connector. If this problem occurs, use a flat-blade screwdriver to push in the release component on the cable connector.

- The CDE2600-60 controller-drive tray supports the DE6600 drive tray for expansion.
- The maximum number of drive slots in the storage array is 180 drive slots, including up to 60 drive slots in the controller-drive tray. Exceeding 180 drive slots makes the storage array invalid. The controllers cannot perform operations that modify the configuration, such as creating new volumes.
- Each controller has one dual-ported SAS expansion connector to connect to the drive trays.

Drive Channel Ports on the CDE2600-60 Controller-Drive Tray – Rear View

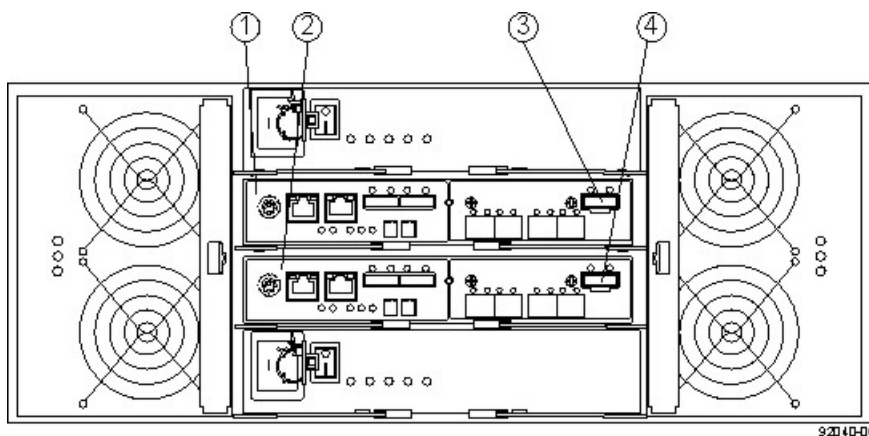

1. Controller A Canister
2. Controller B Canister
3. Controller A SAS Expansion Connector
4. Controller B SAS Expansion Connector

IMPORTANT To maintain data access in the event of the failure of a controller, an ESM, or a drive channel, you must connect a drive tray or a string of drive trays to both drive channels on a redundant path pair.

Things to Know – Drive Trays with the CDE2600-60 Controller-Drive Tray

Each DE6600 drive tray can contain a maximum of sixty 8.89-cm (3.5-in.) drives housed with five drawers of 12 drives each.

DE6600 Drive Tray – Rear View

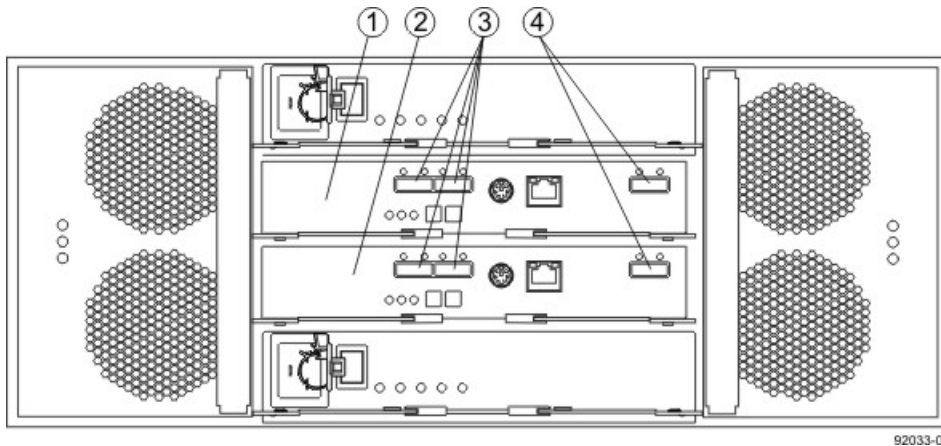

1. ESM A
2. ESM B
3. SAS IN Connectors
4. Expansion Connectors

Things to Know – CDE2600-60 Drive Tray Cabling Configurations – Duplex System

The figures in this topic show examples of cable configurations from the controller-drive tray to the drive trays. Use these examples as guides to connect cables in your storage array.

Controller-Drive Tray Above the Drive Tray

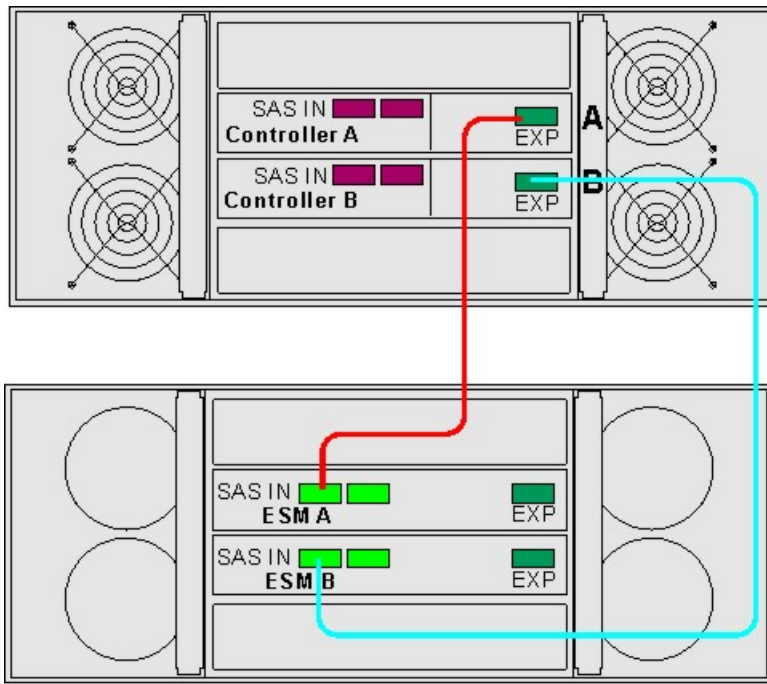

92031-05

Controller-Drive Tray Between Two Drive Trays

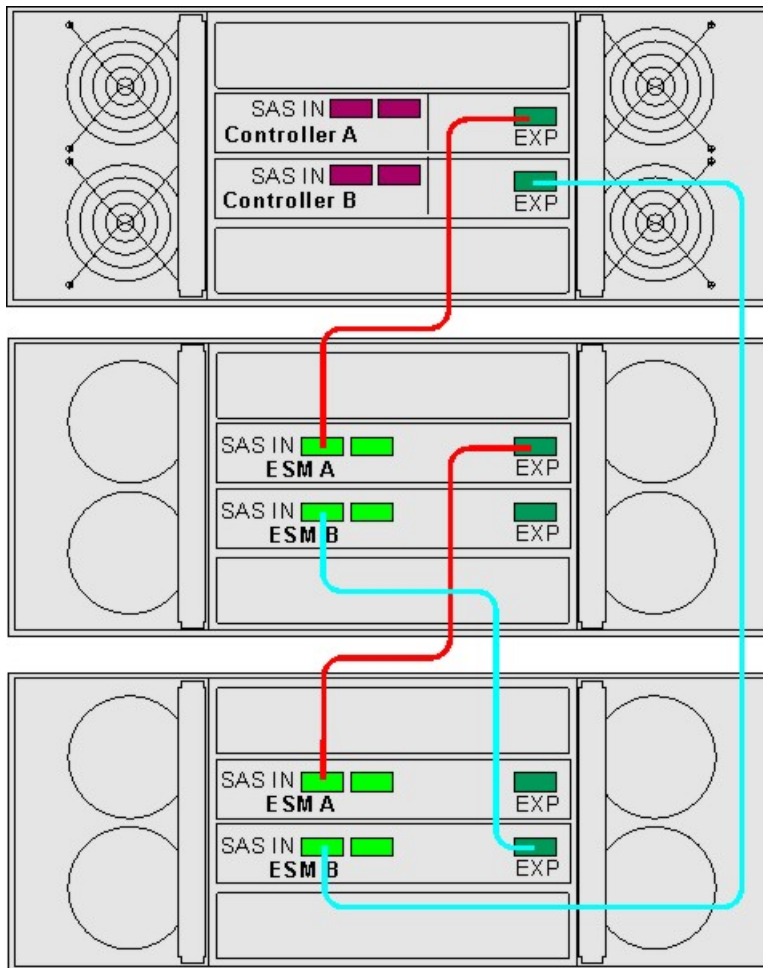

92031-06

Procedure – Connecting the DE6600 Drive Tray

1. Use the following table to determine the number of SAS cables that you need.

Drive Tray Cables

| Number of Drive Trays that You Plan to Connect to the Controller-Drive Tray | Number of Cables Required |
|---|---------------------------|
| 1 | 2 |
| 2 | 4 |

2. If there is a black, plastic plug in the SAS expansion connector of the controller, remove it.
3. Insert one end of the cable into the SAS expansion connector on the controller in slot A in the controller-drive tray.
4. Insert the other end of the cable into the connector with an up arrow on the ESM in slot A in the drive tray.
5. Are you adding more drive trays?

IMPORTANT Each ESM in a drive tray has three expansion connectors: two on the left-center of the ESM and one in the upper-right side. When connecting from an ESM in one drive tray to an ESM in another drive tray, make sure that you connect the connector on the upper-right to one of the connectors on the left-center. The following figure shows these arrows on an ESM. If the cable is connected either between the two left-center ESM connectors or between two upper-right ESM connectors, communication between the two drive trays is lost.

NOTE It does not matter which of the two left-center ESM connectors you use to connect to the expansion connector on the far-right side.

Connecting a Cable from One ESM to a Second ESM

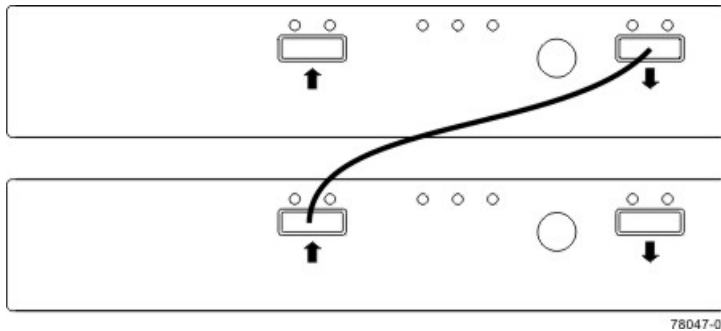

- **Yes** – Go to step 6.
 - **No** – Go to step 9.
6. In the ESM in the first drive tray, insert one end of the cable into the connector on the far-right side.
 7. In the ESM in the next drive tray, insert the other end of the cable into one of the connectors in the left-center of the ESM.
 8. Repeat step 6 through step 7 for each drive tray that you intend to add to the storage array.
 9. To each end of the cables, attach a label with this information:
 - The controller ID (for example, controller A)
 - The ESM ID (for example, ESM A)
 - The ESM connector (In or Out)
 - The drive tray ID

For example, if you are connecting controller A to the In connector on ESM A in drive tray 1, the label on the controller end of the cable will have this information:

CtA-Dch1, Dm1-ESM_A (left), In - Controller End

The label on the drive tray end of the cable will have this information:

Dm1-ESM_A (left), In, CtrlA

10. If you are installing the controller-drive tray with two controllers, repeat step 2 through step 9 for the controller in slot B in the controller-drive tray.



IMPORTANT To connect cables for maximum redundancy, the cables attaching controller B must be connected to the drive trays in the opposite tray order as for controller A. That is, the last drive tray in the chain from controller A must be the first drive tray in the chain from controller B.

Step 8 – Connecting the Ethernet Cables

Key Terms

in-band management

A method to manage a storage array in which a storage management station sends commands to the storage array through the host input/output (I/O) connection to the controller.

out-of-band management

A method to manage a storage array in which a storage management station sends commands to the storage array through the Ethernet connections on the controller.

Things to Know – Connecting Ethernet Cables



ATTENTION Risk of security breach – Connect the Ethernet ports on the controller tray to a private network segment behind a firewall. If the Ethernet connection is not protected by a firewall, your storage array might be at risk of being accessed from outside of your network.

- These Ethernet connections are intended for out-of-band management and have nothing to do with the iSCSI host interface cards (HICs), whether 1Gb/s or 10Gb/s.
- Ethernet port 2 on each controller is reserved for access by your Customer and Technical Support representative.
- In limited situations in which the storage management station is connected directly to the controller tray, you must use an Ethernet crossover cable. An Ethernet crossover cable is a special cable that reverses the pin contacts between the two ends of the cable.

Procedure – Connecting Ethernet Cables

Perform these steps to connect Ethernet cables for out-of-band management. If you use only in-band management, skip these steps.

1. Connect one end of an Ethernet cable into the Ethernet port 1 on controller A.
2. Connect the other end to the applicable network connection.
3. Repeat step 1 through step 2 for controller B.

Step 9 – Connecting the Power Cords

The CDE2600 controller-drive tray, the DE1600 drive tray, and the DE5600 drive tray can have either standard power connections to an AC power source or the optional connections to a DC power source (–48 VDC).



IMPORTANT Make sure that you do not turn on the power to the controller-drive tray or the connected drive trays until this documentation instructs you to do so. For the correct procedure for turning on the power, see “.”

Things to Know – AC Power Cords

- For each AC power connector on the drive tray, make sure that you use a separate power source in the cabinet. Connecting to independent power sources maintains power redundancy.
- To ensure proper cooling and assure availability, the drive trays always use two power supplies.
- You can use the power cords shipped with the controller-drive tray with typical outlets used in the destination country, such as a wall receptacle or an uninterruptible power supply (UPS). These power cords, however, are not intended for use in most EIA-compliant cabinets.

Procedure – Connecting AC Power Cords

1. Make sure that the circuit breakers in the cabinet are turned off.
2. Make sure that both of the Power switches on the controller-drive tray are turned off.
3. Connect the primary power cords from the cabinet to the external power source.
4. Connect a cabinet interconnect power cord (or power cords specific to your particular cabinet) to the AC power connector on each power canister in the drive tray.
5. If you are installing other drive trays in the cabinet, connect a power cord to each power canister in the drive trays.

Step 10 – Turning on the Power and Checking for Problems in a CDE2600-60 Controller-Drive Tray Configuration

Once you complete this task, you can begin to install the software and perform basic configuration tasks on your storage array. Continue with the *Initial Configuration and Software Installation* in these electronic document topics or through the PDF that is available on the SANtricity ES Storage Manager Installation DVD.

Procedure – Turning On the Power to the Storage Array and Checking for Problems in a CDE2600-60 Controller-Drive Tray Configuration



IMPORTANT You must turn on the power to all of the connected drive trays before you turn on the power for the controller-drive tray. Performing this action makes sure that the controllers recognize each attached drive tray.



NOTE While the power is being applied to the trays, the LEDs on the front and the rear of the trays come on and go off intermittently.

1. Turn on both Power switches on each drive tray that is attached to the controller-drive tray. Depending on your configuration, it can take several minutes for each drive tray to complete the power-on process.



IMPORTANT Before you go to step 2, check the LEDs on the drive trays to verify that the power was successfully applied to all of the drive trays. Wait 30 seconds after turning on the power to the drive trays before turning on the power to the controller-drive tray.

2. Turn on both Power switches on the rear of the controller-drive tray. Depending on your configuration, it can take several minutes for the controller-drive tray to complete the power-on process.
3. Check the LEDs on the front and the rear of the controller-drive tray and the attached drive trays.
4. If you see any amber LEDs, make a note of their location.

Things to Know – LEDs on the CDE2600-60 Controller-Drive Tray

The following topics provide details on the LEDs found on the CDE2600-60 controller-drive tray.

LEDs on the Left End Cap

LEDs on the Left End Cap

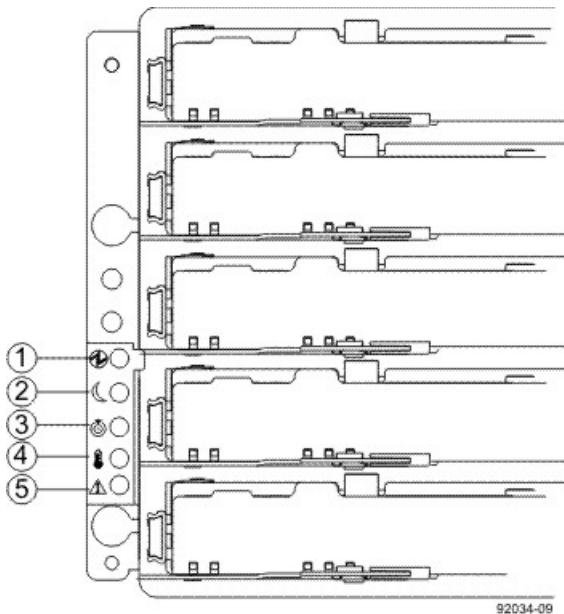

1. Controller-Drive Tray Locate LED
2. Service Action Required LED
3. Controller-Drive Tray Over-Temperature LED
4. Power LED
5. Standby Power LED

LEDs on the Left End Cap

| Location | LED | Color | On | Off |
|----------|--|-------|---|---|
| 1 | Controller-Drive Tray Locate | White | Identifies a controller-drive tray that you are trying to find. | Normal status. |
| 2 | Service Action Required | Amber | A component within the controller-drive tray needs attention. | Normal status. |
| 3 | Controller-Drive Tray Over-Temperature | Amber | The temperature of the controller-drive tray has reached an unsafe level. | Normal status. |
| 4 | Power | Green | Power is present. | Power is not present. |
| 5 | Standby Power | Green | The controller-drive tray is in Standby Power mode. | The controller-drive tray is not in Standby Power mode. |

LEDs on the Controller Canister Main Faceplate

LEDs on the Controller Canister Main Faceplate

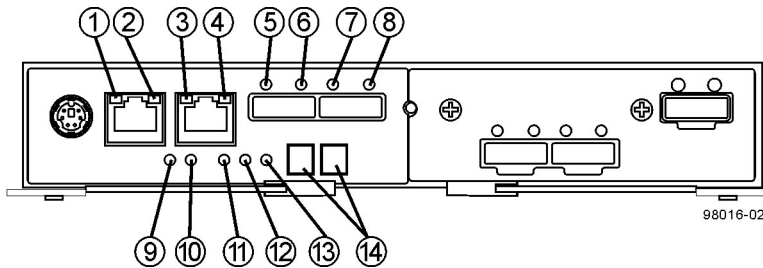

1. Ethernet Connector 1 Link Rate LED
2. Ethernet Connector 1 Link Active LED
3. Ethernet Connector 2 Link Rate LED
4. Ethernet Connector 1 Link Active LED
5. Host Link 1 Service Action Required LED
6. Host Link 1 Service Action Allowed LED
7. Host Link 2 Service Action Required LED
8. Host Link 2 Service Action Allowed LED
9. Battery Service Action Required LED
10. Battery Charging LED
11. Controller Service Action Allowed LED
12. Controller Service Action Required LED
13. Cache Active LED
14. Seven-Segment Tray ID

LEDs on the Controller Canister Main Faceplate

| Location | LED | Color | On | Off |
|----------|---|-------|---|-----------------------------|
| 1 | Ethernet Connector 1 Link Rate LED | Green | There is a 100BASE-T rate. | There is a 10BASE-T rate. |
| 2 | Ethernet Connector 1 Link Active LED | Green | The link is up (LED blinks when there is activity). | The link is not active. |
| 3 | Ethernet Connector 2 Link Rate LED | Green | There is a 100BASE-T rate. | There is a 10BASE-T rate. |
| 4 | Ethernet Connector 2 Link Active LED | Green | The link is up (the LED blinks when there is activity). | The link is not active. |
| 5 | Host Link 1 Service Action Required LED | Amber | At least one of the four PHYs is working, but another PHY cannot establish the same link to the device connected to the Host IN port connector. | No link error has occurred. |

| Location | LED | Color | On | Off |
|---|---|-------|---|---|
| 6 | Host Link 1 Service Action Allowed LED | Green | At least one of the four PHYs in the Host IN port is working and a link exists to the device connected to the IN port connector. | A link error has occurred. |
| 7 | Host Link 2 Service Action Required LED | Amber | At least one of the four PHYs is working, but another PHY cannot establish the same link to the device connected to the Host IN port connector. | No link error has occurred. |
| 8 | Host Link 2 Service Action Allowed LED | Green | At least one of the four PHYs in the Host IN port is working and a link exists to the device connected to the IN port connector. | A link error has occurred. |
| 9 | Battery Service Action Required LED | Amber | The battery in the controller canister has failed. | Normal status. |
| 10 | Battery Charging LED | Green | The battery is fully charged. The LED blinks when the battery is charging. | The controller canister is operating without a battery or the existing battery has failed. |
| 11 | Controller Service Action Allowed LED | Blue | The controller canister can be removed safely from the controller-drive tray. | The controller canister cannot be removed safely from the controller-drive tray. |
| 12 | Controller Service Action Required LED | Amber | A fault exists within the controller canister. | Normal status. |
| 13 | Cache Active LED | Green | Cache is active.* | Cache is inactive or the controller canister has been removed from the controller-drive tray. |
| * After an AC power failure, this LED blinks while cache offload is in process. | | | | |

LEDs on the Controller Canister Host Interface Card Subplates



NOTE The figure immediately below shows an iSCSI host interface card (HIC), but the CDE2600 controller-drive tray also supports a four-connector FC HIC and a two-connector SAS HIC with comparable LEDs.

LEDs on the Controller Canister Host Interface Card Subplates

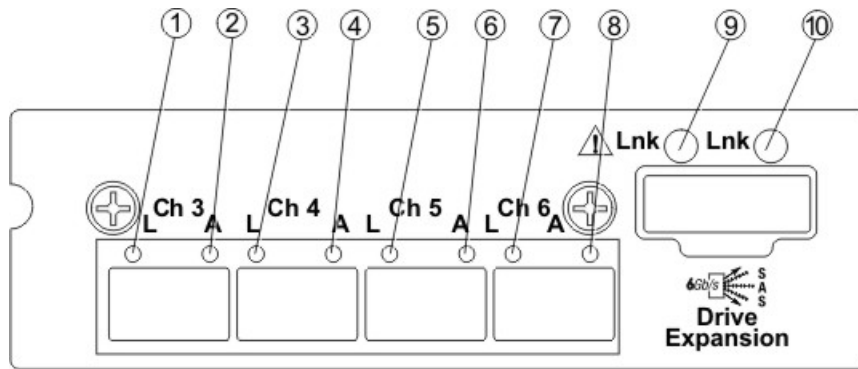

98019-09

1. Host Interface Card Link 3 Up LED
2. Host Interface Card Link 3 Active LED
3. Host Interface Card Link 4 Up LED
4. Host Interface Card Link 4 Active LED
5. Host Interface Card Link 5 Up LED
6. Host Interface Card Link 5 Active LED
7. Host Interface Card Link 6 Up LED
8. Host Interface Card Link 6 Active LED
9. Expansion Fault LED
10. Expansion Active LED

LEDs on the Controller Canister Host Interface Card Subplates*

| Location | LED | Color | On | Off |
|----------|---------------------------------------|-------|---|---|
| 1 | Host Interface Card Link 3 Up LED | Green | The Ethernet link has auto-negotiated to 1 Gb/s. | The Ethernet link is down or does not auto-negotiate to 1 Gb/s. |
| 2 | Host Interface Card Link 3 Active LED | Green | The link is up (LED blinks when there is activity). | The link is not active. |
| 3 | Host Interface Card Link 4 Up LED | Green | The Ethernet link has auto-negotiated to 1 Gb/s. | The Ethernet link is down or does not auto-negotiate to 1 Gb/s. |
| 4 | Host Interface Card Link 4 Active LED | Green | The link is up (LED blinks when there is activity). | The link is not active. |
| 5 | Host Interface Card Link 5 Up LED | Green | The Ethernet link has auto-negotiated to 1 Gb/s. | The Ethernet link is down or does not auto-negotiate to 1 Gb/s. |
| 6 | Host Interface Card Link 5 Active LED | Green | The link is up (LED blinks when there is activity). | The link is not active. |

| Location | LED | Color | On | Off |
|----------|---------------------------------------|-------|---|---|
| 7 | Host Interface Card Link 6 Up LED | Green | The Ethernet link has auto-negotiated to 1 Gb/s. | The Ethernet link is down or does not auto-negotiate to 1 Gb/s. |
| 8 | Host Interface Card Link 6 Active LED | Green | The link is up (LED blinks when there is activity). | The link is not active. |
| 9 | Expansion Fault LED | Amber | At least one of the four PHY is working, but another PHY cannot establish the same link to the device connected to the Expansion OUT connector. | Normal status. |
| 10 | Expansion Active LED | Green | At least one of the four PHYs in the OUT connector is working and a link has been made to the device connected to the Expansion connector. | The link is not active. |

* "LEDs on the Controller Canister Host Interface Card Subplates" shows the four-port iSCSI host interface card (HIC), which can also be a four-port FC HIC or a two-port SAS HIC.

LEDs on the Power-Fan Canister

LEDs on the Power-Fan Canister

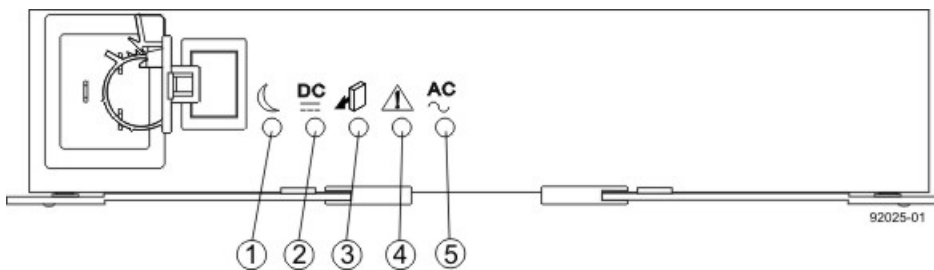

1. Standby Power LED
2. Power-Fan DC Power LED
3. Power-Fan Service Action Allowed LED
4. Power-Fan Service Action Required LED
5. Power-Fan AC Power LED



LEDs on the Power-Fan Canister







| Location | LED | Color | On | Off |
|----------|---------------|-------|--|--|
| 1 | Standby Power | Green | The controller-drive tray is in Standby mode, and DC power is not available. | The controller-drive tray is not in Standby mode, and DC power is available. |





| Location | LED | Color | On | Off |
|----------|-----------------------------------|-------|--|---|
| 2 | Power-Fan DC Power | Green | DC power from the power-fan canister is available. | DC power from the power-fan canister is not available. |
| 3 | Power-Fan Service Action Allowed | Blue | The power-fan canister can be removed safely from the controller-drive tray. | The power-fan canister cannot be removed safely from the controller-drive tray. |
| 4 | Power-Fan Service Action Required | Amber | A fault exists within the power-fan canister. | Normal status. |
| 5 | Power-Fan AC Power | Green | AC power to the power-fan canister is present. | AC power to the power-fan canister is not present. |

Things to Know – General Behavior of the LEDs on the CDE2600 Controller-Drive Tray

LED Symbols and General Behavior

| LED | Symbol | Location (Canisters) | Function |
|------------------------|---|---|---|
| Power |  | Power-fan Interconnect-battery | <ul style="list-style-type: none"> ▪ On – The controller has power. ▪ Off – The controller does not have power. <p>NOTE – The controller canisters do not have a Power LED. They receive their power from the power supplies inside the power-fan canisters.</p> |
| Battery Fault |  | Battery | <ul style="list-style-type: none"> ▪ On – The battery is missing or has failed. ▪ Off – The battery is operating normally. ▪ Blinking – The battery is charging. |
| Service Action Allowed |  | Drive (left LED, no symbol) Power-fan Controller Battery | On – You can remove the canister safely. See “Things to Know – Service Action Allowed LEDs.” |

| LED | Symbol | Location (Canisters) | Function |
|--|---|--|---|
| Service Action Required (Fault) |  | Drive | <p>On – When the drive tray LED is on, the cable is attached and at least one lane has a link up status, but at least one lane has a link down status.</p> <p>Off – One of the following conditions exists:</p> <ul style="list-style-type: none"> ▪ No cable is attached. ▪ A cable is attached, and all lanes have a link up status. ▪ A cable is attached, and all lanes have a link down status. |
| Service Action Required (Fault) |  | Controller Power-fan canister | <p>On – The controller or the power-fan canister needs attention.</p> <p>Off – The controller and the power-fan canister are operating normally.</p> |
| Locate |  | Front frame | <p>On – Assists in locating the tray.</p> |
| Host Channel Connection (iSCSI) |  | Controller | <p>The status of the host channel is indicated:</p> <ul style="list-style-type: none"> ▪ “L” LED on – A link is established. ▪ “A” LED on – Activity (data transfer) is present. |
| Cache Active |  | Controller | <p>The activity of the cache is indicated:</p> <ul style="list-style-type: none"> ▪ On – Data is in the cache. ▪ Off – No data is in the cache. |
| Controller-Drive Tray Over-Temperature |  | Front bezel on the controller-drive tray | <p>On – The temperature of the drive tray has reached an unsafe condition.</p> |

| LED | Symbol | Location (Canisters) | Function |
|--------------------------------------|---|---|---|
| | | | Off – The temperature of the drive tray is within operational range. |
| Standby Power |  | Front bezel on the controller-drive tray | On – The controller tray is in standby mode and the main DC power is off. Off – The controller-drive tray is not in standby mode and the main DC power is on. |
| Seven-Segment ID Diagnostic Display |  | Controller | The tray ID or a diagnostic code is indicated (see “Things to Know – Dynamic Display Sequence Definitions on the Seven-Segment Display”). For example, if some of the cache memory dual in-line memory modules (DIMMs) are missing in a controller, error code L8 appears in the diagnostic display (see “Things to Know – Supported Diagnostic Lock-Down Codes on the Seven-Segment Display”). |
| AC power |  | Power-fan NOTE – The LED is directly above or below the AC power switch and the AC power connector. | Indicates that the power supply is receiving AC power input. |
| DC power |  | Power-fan NOTE – The LED is directly above or below the DC power switch and the DC power connector. | Indicates that the power supply is receiving DC power input. |
| Ethernet Speed and Ethernet Activity |  | Controller | The speed of the Ethernet ports and whether a link has been established are indicated: <ul style="list-style-type: none"> ▪ Left LED On – 1-Gb/s speed. |

| LED | Symbol | Location (Canisters) | Function |
|-----|--------|----------------------|--|
| | | | <ul style="list-style-type: none"> ▪ Left LED Off – 100BASE-T or 10BASE-T speed. ▪ Right LED On – A link is established. ▪ Right LED Off – No link exists. ▪ Right LED blinking – Activity is occurring. |

LEDs on the DE6600 Drive Tray

LEDs on the Left End Cap

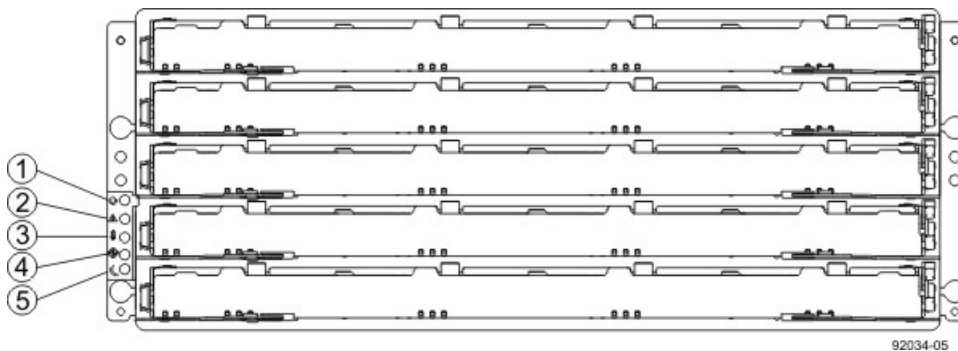

1. Drive Tray Locate LED
2. Drive Tray Service Action Required LED
3. Drive Tray Over-Temperature LED
4. Power LED
5. Standby Power LED

LEDs on the Left End Cap

| Location | LED | Color | On | Off |
|----------|-----------------------------|-------|--|-----------------------|
| 1 | Drive Tray Locate | White | Identifies a drive tray that you are trying to find. | Normal status. |
| 2 | Service Action Required | Amber | A component within the drive tray needs attention. | Normal status. |
| 3 | Drive Tray Over-Temperature | Amber | The temperature of the drive tray has reached an unsafe level. | Normal status. |
| 4 | Power | Green | Power is present. | Power is not present. |

| Location | LED | Color | On | Off |
|----------|---------------|-------|--|--|
| 5 | Standby Power | Green | The drive tray is in Standby Power mode. | The drive tray is not in Standby Power mode. |

LEDs on the ESM Canister

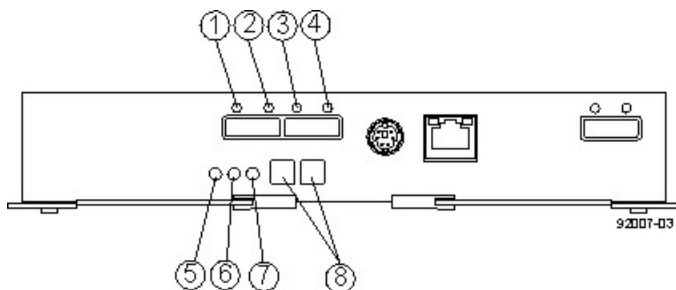

1. ESM Link Fault LED (Port 1A Bypass)
2. ESM Link LED (Port 1A Data Rate)
3. ESM Link LED (Port 1B Data Rate)
4. ESM Link Fault LED (Port 1B Bypass)
5. ESM Service Action Allowed LED
6. ESM Service Action Required LED
7. ESM Power LED
8. Seven-Segment Tray ID

LEDs on the ESM Canister

| Location | LED | Color | On | Off |
|----------|---------------------------------|-------|--|---|
| 1 | ESM Link Fault (Port 1A Bypass) | Amber | A link error has occurred. | No link error has occurred. |
| 2 | ESM Link (Port 1A) | Green | The link is up. | A link error has occurred. |
| 3 | ESM Link (Port 1B Bypass) | Green | The link is up. | A link error has occurred. |
| 4 | ESM Link Fault (Port 1B) | Amber | A link error has occurred. | No link error has occurred. |
| 5 | ESM Service Action Allowed | Blue | The ESM can be removed safely from the drive tray. | The ESM cannot be removed safely from the drive tray. |
| 6 | ESM Service Action Required | Amber | A fault exists within the ESM. | Normal status. |
| 7 | ESM Power | Green | Power to the ESM is present. | Power is not present to the ESM. |

| Location | LED | Color | On | Off |
|----------|-----------------------|-------|--|-----------------|
| 8 | Seven-Segment Tray ID | Green | For more information, see “Supported Diagnostic Codes on the Seven-Segment Display”. | Not applicable. |

LEDs on the Power Canister

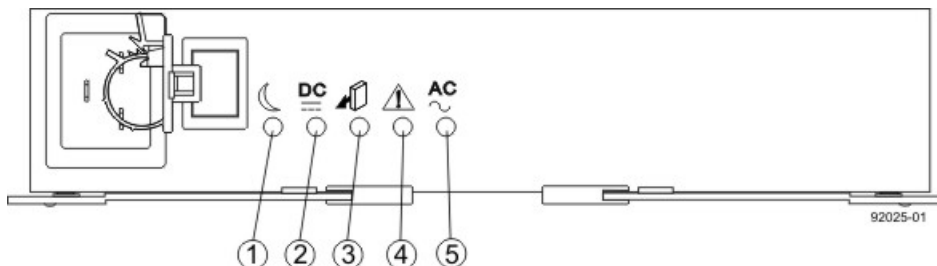

1. Standby Power LED
2. Power DC Power LED
3. Power Service Action Allowed LED
4. Power Service Action Required LED
5. Power AC Power LED

LEDs on the Power Canister

| Location | LED | Color | On | Off |
|----------|-------------------------------|-------|--|--|
| 1 | Standby Power | Green | The drive tray is in Standby mode and DC power is not available. | The drive tray is not in Standby mode and DC power is available. |
| 2 | Power DC Power | Green | DC power from the power canister is available. | DC power from the power canister is not available. |
| 3 | Power Service Action Allowed | Blue | The power canister can be removed safely from the drive tray. | The power canister cannot be removed safely from the drive tray. |
| 4 | Power Service Action Required | Amber | A fault exists within the power canister. | Normal status. |
| 5 | Power AC Power | Green | AC power to the power canister is present. | AC power to the power canister is not present. |

LEDs on the Fan Canister

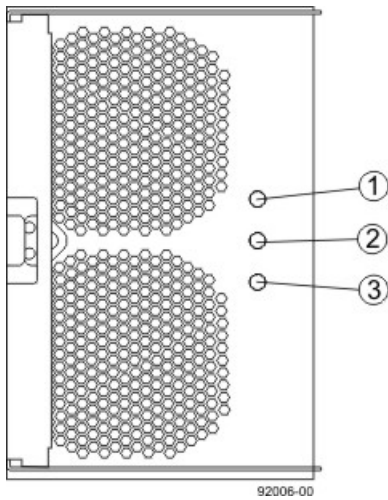

1. Power LED
2. Service Action Required LED
3. Service Action Allowed LED

LEDs on the Fan Canister

| Location | LED | Color | On | Off |
|----------|-------------------------|-------|---|--|
| 1 | Power | Green | Power from the fan canister is available. | Power to the fan customer-replaceable unit (CRU) is available. |
| 2 | Service Action Required | Amber | A fault exists within the fan canister. | Normal status. |
| 3 | Service Action Allowed | Blue | The fan canister can be removed safely from the drive tray. | The fan canister cannot be removed safely from the drive tray. |

LEDs on the DE6600 Drive Drawers

LEDs on the Drawer

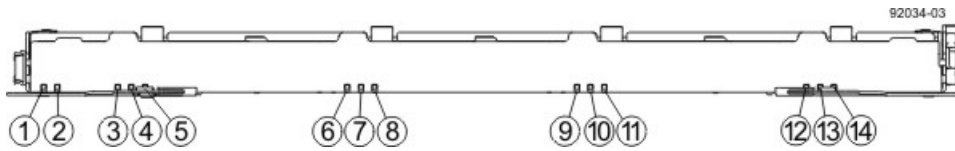

1. Drive Drawer Status Service Action Required LED
2. Drive Drawer Status Service Action Allowed LED
3. Drive 1 Activity LED
4. Drive 2 Activity LED
5. Drive 3 Activity LED
6. Drive 4 Activity LED
7. Drive 5 Activity LED
8. Drive 6 Activity LED
9. Drive 7 Activity LED
10. Drive 8 Activity LED
11. Drive 9 Activity LED
12. Drive 10 Activity LED
13. Drive 11 Activity LED
14. Drive 12 Activity LED

LEDs on the Drawer

| Location | LED | Color | On | Blinking | Off |
|----------|--|-------|---|-------------------------------------|--|
| 1 | Drive Drawer Service Action Required | Amber | An error has occurred. | | Normal status. |
| 2 | Drive Drawer Service Action Allowed | Blue | The drive canister can be removed safely from the drive drawer in the drive tray. | | The drive canister cannot be removed safely from the drive drawer in the drive tray. |
| 2 | Drive or Drawer Service Action Required | Amber | An error has occurred. | | Normal status. |
| 3–14 | Drive Activity for drives 1 through 12 in the drive drawer | Green | The power is turned on, and the drive is operating normally. | Drive I/O activity is taking place. | The power is turned off. |

Drive State Represented by the LEDs

| Drive State | Drive Activity LED (Green) | Drive Service Action Required LED (Amber) |
|-----------------------|----------------------------|---|
| Power is not applied. | Off | Off |

| Drive State | Drive Activity LED (Green) | Drive Service Action Required LED (Amber) |
|---|----------------------------|---|
| Normal operation – The power is turned on, but drive I/O activity is not occurring. | On | Off |
| Normal operation – Drive I/O activity is occurring. | Blinking | Off |
| Service action required – A fault condition exists, and the drive is offline. | On | On |

LEDs on the DE6600 Drives

LEDs on the DE6600 Drive



1. Drive Service Action Allowed LED
2. Drive Service Action Required LED

LEDs on the Drives





| Location | LED | Color | On | Blinking | Off |
|----------|---|-------|---|----------|--|
| 1 | Drive Drawer Service Action Allowed | Blue | The drive canister can be removed safely from the drive drawer in the drive tray. | | The drive canister cannot be removed safely from the drive drawer in the drive tray. |
| 2 | Drive or Drawer Service Action Required | Amber | An error has occurred. | | Normal status. |





Drive State Represented by the LEDs

| Drive State | Drive Activity LED (Green) | Drive Service Action Required LED (Amber) |
|---|----------------------------|---|
| Power is not applied. | Off | Off |
| Normal operation – The power is turned on, but drive I/O activity is not occurring. | On | Off |
| Normal operation – Drive I/O activity is occurring. | Blinking | Off |
| Service action required – A fault condition exists, and the drive is offline. | On | On |

General Behavior of the LEDs on the DE6600 Drive Tray

DE6600 Drive Tray LED Symbols and General Behavior

| LED | Symbol | Location | General Behavior |
|-----------------------------|---|---|---|
| Power |  | Drive tray ESM canister Power-fan canister | On – Power is applied to the drive tray or the canister. Off – Power is not applied to the drive tray or the canister. |
| Drive Tray Locate |  | Front bezel on the drive tray | On or blinking – Indicates the drive tray that you are trying to find. |
| Drive Tray Over-Temperature |  | Front bezel on the drive tray | On – The temperature of the drive tray has reached an unsafe condition. Off – The temperature of the drive tray is within operational range. |
| Standby Power |  | Front bezel on the drive tray | On – The drive tray is in Standby mode, and the main DC power is off. Off – The drive tray is not in Standby mode, and the main DC power is on. |
| Service Action Allowed |  | ESM canister Power-fan canister Drive | On – It is safe to remove the ESM canister, the power-fan canister, or the drive. Off – Do not remove the ESM canister, the power-fan canister, or the drive. The drive has an LED but no symbol. |

| LED | Symbol | Location | General Behavior |
|--------------------------------------|---|---|--|
| Service Action Required (Fault) |  | ESM canister Power-fan canister Drive | On – When the drive tray LED is on, a component within the drive tray needs attention. On – The ESM canister, the power-fan canister, or the drive needs attention. Off – The ESM canister, the power-fan canister, and the drive are operating normally. The drive has an LED but no symbol. |
| AC Power | AC  | ESM canister Power-fan canister | On – AC power is present. Off – AC power is not present. |
| DC Power | DC  | Power-fan canister | On – Regulated DC power from the power canister and the fan canister is present. Off – Regulated DC power from the power-fan canister is not present. |
| Link Service Action Required (Fault) |  | ESM canister | On – The cable is attached and at least one lane has a link-up status, but one lane has a link-down status. Off – The cable is not attached, the cable is attached and all lanes have a link-up status, or the cable is attached and all lanes have a link-down status. |
| Link Up | Two LEDs above each expansion connector | ESM canister | On – The cable is attached and at least one lane has a link-up status. Off – The cable is not attached, or the cable is attached and all lanes have a link-down status. |

Things to Know – Service Action Allowed LEDs

Each controller canister, power-fan canister, and battery canister has a Service Action Allowed LED. The Service Action Allowed LED lets you know when you can remove a canister safely.

 **ATTENTION Possible loss of data access** – Never remove a controller canister, a power-fan canister, or a battery canister unless the appropriate Service Action Allowed LED is on.

If a controller canister or a power-fan canister fails and must be replaced, the Service Action Required (Fault) LED on that canister comes on to indicate that service action is required. The Service Action Allowed LED also comes on if it is safe to remove the canister. If data availability dependencies exist or other conditions that dictate a canister should not be removed, the Service Action Allowed LED stays off.

The Service Action Allowed LED automatically comes on or goes off as conditions change. In most cases, the Service Action Allowed LED comes on when the Service Action Required (Fault) LED comes on for a canister.

 **NOTE** If the Service Action Required (Fault) LED comes on but the Service Action Allowed LED is off for a particular canister, you might need to service another canister first. Check your storage management software to determine the action that you should take.

Things to Know – Sequence Code Definitions for the CDE2600-60 Controller-Drive Tray

During normal operation, the tray ID display on each controller canister displays the controller-drive tray ID. The Diagnostic LED (lower-digit decimal point) comes on when the display is used for diagnostic codes and goes off when the display is used to show the tray ID.

Sequence Code Definitions for the CDE2600-60 Controller-Drive Tray

| Category | Category Code (See Note 1) | Detail Codes (See Note 2) |
|--------------------|----------------------------|---|
| Startup error | SE+ (See Note 3) | <ul style="list-style-type: none"> ▪ 88+ Power-on default. ▪ dF+ Power-on diagnostic fault. |
| Operational error | OE+ | Lx+ Lock-down codes (See the following table.) |
| Operational state | OS+ | <ul style="list-style-type: none"> ▪ OL+ = Offline. ▪ bb+ = Battery backup (operating on batteries). ▪ Cf+ = Component failure. |
| Component failure | CF+ | <ul style="list-style-type: none"> ▪ dx+ = Processor or cache DIMM. ▪ Cx = Cache DIMM. ▪ Px+ = Processor DIMM. ▪ Hx+ = Host interface card. ▪ Fx+ = Flash drive. |
| Diagnostic failure | dE+ | Lx+ = Lock-down code. |
| Category delimiter | dash+ | The separator between category-detail code pairs is used when more than one category detail code pair exists in the sequence. |

| Category | Category Code (See Note 1) | Detail Codes (See Note 2) |
|--|----------------------------|--|
| End-of-sequence delimiter | Blank (See Note 4) | The end-of-sequence delimiter is automatically inserted by the hardware at the end of a code sequence. |
| Notes: 1 A two-digit code that starts a dynamic display sequence. 2 A two-digit code that follows the category code with more specific information. 3 The plus (+) sign indicates that a two-digit code displays with the Diagnostic LED on. 4 No codes display, and the Diagnostic LED is off. | | |

Things to Know – Lock-Down Codes for the CDE2600-60 Controller-Drive Tray

Use the following table to determine the diagnostic lock-down code definitions on the Seven-Segment Display in the controller canister for the CDE2600-60 controller-drive tray.

Supported Diagnostic Lock-Down Codes on the Seven-Segment Display

| Diagnostic Code | Description |
|-----------------|--|
| -- | The firmware is booting. |
| .8, 8., or 88 | This ESM is being held in reset by another ESM. |
| AA | The ESM A firmware is in the process of booting (the diagnostic indicator is not yet set). |
| bb | The ESM B firmware is in the process of booting (the diagnostic indicator is not yet set). |
| L0 | The controller types are mismatched, which result in a suspended controller state. |
| L2 | A persistent memory error has occurred, which results in a suspended controller state. |
| L3 | A persistent hardware error has occurred, which results in a suspended controller state. |
| L4 | A persistent data protection error has occurred, which results in a suspended controller state. |
| L5 | An auto-code synchronization (ACS) failure has been detected, which results in a suspended controller state. |
| L6 | An unsupported host interface card has been detected, which results in a suspended controller state. |

| Diagnostic Code | Description |
|-----------------|---|
| L7 | A sub-model identifier either has not been set or has been mismatched, which results in a suspended controller state. |
| L8 | A memory configuration error has occurred, which results in a suspended controller state. |
| L9 | A link speed mismatch condition has been detected in either the ESM or the power supply, which results in a suspended controller state. |
| Lb | A host interface card configuration error has been detected, which results in a suspended controller state. |
| LC | A persistent cache backup configuration error has been detected, which results in a suspended controller state. |
| Ld | A mixed cache memory DIMMs condition has been detected, which results in a suspended controller state. |
| LE | Uncertified cache memory DIMM sizes have been detected, which result in a suspended controller state. |
| LF | The controller has locked down in a suspended state with limited symbol support. |
| LH | A controller firmware mismatch been detected, which results in a suspended controller state. |
| LL | The controller cannot access either midplane SBB EEPROM, which results in a suspended controller state. |
| Ln | A canister is not valid for a controller, which results in a suspended controller state. |
| LP | Drive port mapping tables are not detected, which results in a suspended controller state. |
| LU | The start-of-day (SOD) reboot limit has been exceeded, which results in a suspended controller state. |

Things to Know – Diagnostic Code Sequences for the CDE2600-60 Controller-Drive Tray

Use the following table to determine the code sequences on the Seven-Segment Display in the controller canister for the CDE2600-60 controller-drive tray. These repeating sequences can be used to diagnose potential problems with the controller tray.

Diagnostic Code Sequences for the CDE2600-60 Controller-Drive Tray

| Displayed Diagnostic Code Sequences | Description |
|-------------------------------------|---|
| SE+ 88+ blank- | One of the following power-on conditions exists: <ul style="list-style-type: none"> ▪ Controller power-on ▪ Controller insertion ▪ Controller inserted while held in reset |
| xy - | Normal operation. |
| OS+ Sd+ blank- | Start-of-day (SOD) processing. |
| OS+ OL+ blank- | The controller is placed in reset while displaying the tray ID. |
| OS+ bb+ blank- | The controller is operating on batteries (cache backup). |
| OS+ CF+ Hx + blank- | A failed host card has been detected. |
| OS+ CF+ Fx + blank- | A failed flash drive has been detected. |
| SE+ dF + blank- | A non-replaceable component failure has been detected. |
| SE+ dF + dash+ CF+ Px + blank- | A processor DIMM failure has been detected. |
| SE+ dF + dash+ CF+ Cx + blank- | A cache memory DIMM failure has been detected. |
| SE+ dF + dash+ CF+ dx + blank- | A processor or cache DIMM failure has been detected. |
| SE+ dF + dash+ CF+ Hx + blank- | A host card failure has been detected. |
| OE+ Lx + blank- | A lockdown condition has been detected. |
| OE+ L2+ dash+ CF+ Px + blank- | Persistent processor DIMM ECC errors have been detected, which result in a suspended controller state. |
| OE+ L2+ dash+ CF+ Cx + blank- | Persistent cache DIMM ECC errors have been detected, which result in a suspended controller state. |
| OE+ L2+ dash+ CF+ dx + blank- | Persistent processor or cache DIMM ECC errors have been detected, which result in a suspended controller state. |

| Displayed Diagnostic Code Sequences | Description |
|-------------------------------------|--|
| OE+ LC+ blank- | The write-protect switch is set during cache restore, which results in a suspended controller state. |
| OE+ LC+ dd + blank- | The memory size is changed from bad data in the flash drives, which results in a suspended controller state. |
| DE+ L2+ dash+ CF+ Cx + blank- | A cache memory diagnostic has been reported failed, which results in a suspended controller state. |

Supported Diagnostic Codes for the DE6600 Drive Tray on the Seven-Segment Display

Supported Diagnostic Codes

| Diagnostic Code | Description |
|-----------------|--|
| -- | The firmware is booting. |
| .8, 8., or 88 | This ESM is being held in reset by another ESM. |
| AA | ESM A firmware is in the process of booting (the diagnostic indicator is not yet set). |
| bb | ESM B firmware is in the process of booting (the diagnostic indicator is not yet set). |
| L0 | The controller types are mismatched. |
| L2 | A persistent memory error has occurred. |
| L3 | A persistent hardware error has occurred. |
| L9 | An over-temperature condition has been detected in either the ESM or the power supply. |
| H0 | An ESM Fibre Channel interface failure has occurred. |
| H1 | An SFP transceiver speed mismatch (a 2-Gb SFP transceiver is installed when the drive tray is operating at 4 Gb) indicates that an SFP transceiver must be replaced. Look for the SFP transceiver with a blinking amber LED. |
| H2 | The ESM configuration is invalid or incomplete, operating in Degraded state. |
| H3 | The maximum number of ESM reboot attempts has been exceeded. |

| Diagnostic Code | Description |
|-----------------|---|
| H4 | This ESM cannot communicate with the alternate ESM. |
| H5 | A midplane harness failure has been detected in the drive tray. |
| H6 | A catastrophic ESM hardware failure has been detected. |
| H9 | A non-catastrophic hardware failure has occurred. The ESM is operating in a Degraded state. |
| J0 | The ESM canister is incompatible with the drive tray firmware. |

CE5400 Controller-Drive Tray Installation

This topic provides basic information for installing the CE5400 controller-drive trays and the corresponding drive trays (the DE1600 drive tray, the DE5600 drive tray, and the DE6600 drive tray) in a storage array. The CE5400 controller-drive trays include the CE5400-60 controller-drive tray, the CE5400-24 controller-drive tray, and the CE5400-12 controller-drive tray. After you have completed these tasks, go to the *Initial Configuration and Software Installation* electronic document topics or the PDF on the SANtricity ES Storage Manager Installation DVD.

The CE5400 controller-drive trays are available in a High Performance Computing (HPC) configuration. The HPC configuration restricts some options in order to provide higher performance in HPC applications. The CE5400-24 controller-drive tray and the CE5400-12 controller-drive tray are available with a DC power option.

Step 1 – Preparing for a CE5400 Controller-Drive Tray Installation

These steps apply to storage arrays with a CE5400 controller-drive tray connected to one or more hosts through Fibre Channel or InfiniBand. The controller-drive tray might also have SAS connections to one or more supported drive trays. All of the trays are installed in cabinets. Use this document to install the CE5400 controller-drive tray and all attached drive trays for your configuration.

The following considerations apply to all CE5400 controller-drive trays.

- Do not exceed a maximum of 384 drives for the standard configuration.
- Do not exceed a maximum of 240 drives for the high performance computing (HPC) configuration.
- Do not exceed a maximum of 15 attached drive trays.
- Each controller-drive tray has two 6-Gb/s drive connectors: one on each controller.
- Each controller has four base Fibre Channel host ports.
- Each controller supports an optional host interface card (HIC) with four Fibre Channel host ports or two InfiniBand host ports.
- Do not mix host connection types. If a controller-drive tray connects to a host using the InfiniBand connections on a HIC, do not use the base Fibre Channel connectors on that controller.
- Each controller supports 6 Gb, 12 Gb, or 24 Gb of cache memory.

The following table shows the various configuration options.

Storage Array Configurations with CE5400 Controller-Drive Trays

| Controller-Drive Tray | Drive Trays (Standard Configuration) | Drive Trays (HPC Configuration) |
|---------------------------------|---|---|
| CE5400-60 controller-drive tray | Attach DE1600 drive trays, DE5600 drive trays, and DE6600 drive trays in various combinations. The following limits assume that the controller-drive tray has 60 drives installed. <ul style="list-style-type: none"> ▪ Attach up to five DE6600 drive trays ▪ Attach up to 13 DE5600 drive trays ▪ Attach up to 15 DE1600 drive trays | Attach DE1600 drive trays, DE5600 drive trays, and DE6600 drive trays in various combinations. The following limits assume that the controller-drive tray has 60 drives installed. <ul style="list-style-type: none"> ▪ Attach up to three DE6600 drive trays ▪ Attach up to seven DE5600 drive trays ▪ Attach up to 15 DE1600 drive trays |
| CE5400-24 controller-drive tray | Attach DE1600 drive trays, DE5600 drive trays, and DE6600 drive trays in various combinations. The following limits assume that the controller-drive tray has 60 drives installed. <ul style="list-style-type: none"> ▪ Attach up to six DE6600 drive trays ▪ Attach up to 15 DE5600 drive trays ▪ Attach up to 15 DE1600 drive trays | Attach DE1600 drive trays, DE5600 drive trays, and DE6600 drive trays in various combinations. The following limits assume that the controller-drive tray has 60 drives installed. <ul style="list-style-type: none"> ▪ Attach up to three DE6600 drive trays ▪ Attach up to nine DE5600 drive trays ▪ Attach up to 15 DE1600 drive trays |

| Controller-Drive Tray | Drive Trays (Standard Configuration) | Drive Trays (HPC Configuration) |
|---------------------------------|---|---|
| CE5400-12 controller-drive tray | <p>Attach DE1600 drive trays, DE5600 drive trays, and DE6600 drive trays in various combinations. The following limits assume that the controller-drive tray has 60 drives installed.</p> <ul style="list-style-type: none"> ▪ Attach up to six DE6600 drive trays ▪ Attach up to 15 DE5600 drive trays ▪ Attach up to 15 DE1600 drive trays | <p>Attach DE1600 drive trays, DE5600 drive trays, and DE6600 drive trays in various combinations. The following limits assume that the controller-drive tray has 60 drives installed.</p> <ul style="list-style-type: none"> ▪ Attach up to three DE6600 drive trays ▪ Attach up to nine DE5600 drive trays ▪ Attach up to 15 DE1600 drive trays |

 **ATTENTION Possible hardware damage** – To prevent electrostatic discharge damage to the tray, use proper antistatic protection when handling tray components.

Key Terms

storage array

A collection of both physical components and logical components for storing data. Physical components include drives, controllers, fans, and power supplies. Logical components include volume groups and volumes. These components are managed by the storage management software.

controller-drive tray

One tray with drives, one or two controllers, fans, and power supplies. The controller-drive tray provides the interface between a host and a storage array.

controller

A circuit board and firmware that is located within a controller tray or a controller-drive tray. A controller manages the input/output (I/O) between the host system and data volumes.

drive tray

One tray with drives, one or two environmental services monitors (ESMs), power supplies, and fans. A drive tray does not contain controllers.

environmental services monitor (ESM)

A canister in the drive tray that monitors the status of the components. An ESM also serves as the connection point to transfer data between the drive tray and the controller.

Small Form-factor Pluggable (SFP) transceiver

A component that enables Fibre Channel duplex communication between storage array devices. SFP transceivers can be inserted into host bus adapters (HBAs), controllers, and environmental services monitors (ESMs). SFP transceivers can support either copper cables (the SFP transceiver is integrated with the cable) or fiber-optic cables (the SFP transceiver is a separate component from the fiber-optic cable).





Gathering Items

Before you start installing the controller-drive tray, you must have installed the cabinet in which the controller-drive tray will be mounted.

Use the tables in this section to verify that you have all of the necessary items to install the controller-drive tray.

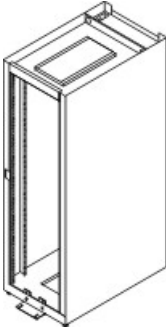
Basic Hardware

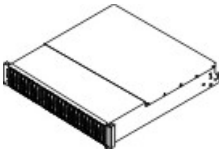
Basic Hardware





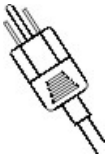

| | Item | Included with the Controller-Drive Tray |
|---|---|---|
|  | <p>Cabinet</p> <ul style="list-style-type: none"> ▪ Make sure that your cabinet meets the installation site specifications of the various CE5400 storage array components. Refer to the <i>Storage System Site Preparation Guide</i> for more information. ▪ Depending on the power supply limitations of your cabinet, you might need to install more than one cabinet to accommodate the different components of the CE5400 storage array. Refer to the installation guide for your cabinet for instructions on installing the cabinet. | |
|  | <p>DE1600 drive tray with end caps that are packaged separately.</p> | |
|  | <p>DE5600 drive tray with end caps that are packaged separately.</p> | |
|  | <p>DE6600 drive tray with end caps that are packaged separately.</p> | |

| | Item | Included with the Controller-Drive Tray |
|---|---|---|
|  | <p>Mounting rails and screws</p> <p>The mounting rails that are available with the drive tray are designed for an industry-standard cabinet.</p> | |
| | Fibre Channel switch (optional) | |
| | <ul style="list-style-type: none"> ▪ Host with Fibre Channel host bus adapters (HBAs) (optional) ▪ Host with InfiniBand host channel adapters (HCAs) (optional) | |

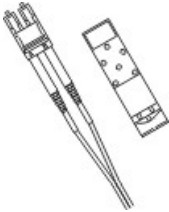
CE5400 Configuration Cables and Connectors

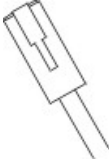
Cables and Connectors

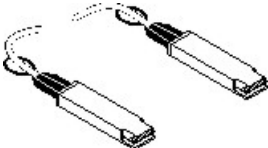
| | Item | Included with the Controller-Drive Tray or Drive Trays |
|---|---|--|
|  | <p>AC power cords.</p> <p>The controller-drive tray and the drive trays ship with power cords for connecting to an external power source, such as a wall plug. Your cabinet might have special power cords that you use instead of the power cords that ship with the controller-drive tray and the drive trays.</p> | ✓ |
| | <p>(Optional – CE5400-24 controller-drive tray and CE5400-12 controller-drive tray only)</p> <ul style="list-style-type: none"> ▪ Two DC power connector cables are provided with each drive tray for connection to centralized DC power plant equipment. ▪ Four DC power connector cables are provided if additional redundancy is required. ▪ A qualified service person is required to make the DC power connection per NEC and CEC guidelines. A two-pole 20-amp circuit breaker is required between the DC power source and the drive tray for over-current and short-circuit protection. Before turning off any power switches on a DC-powered drive tray, first you must disconnect the two-pole 20-amp circuit breaker. | ✓ For the DC power option only |

| | Item | Included with the Controller-Drive Tray or Drive Trays |
|---|--|---|
|  | <p>Fiber-optic cables – Use for FC connections to hosts. Small Form-factor Pluggable (SFP) transceivers</p> <ul style="list-style-type: none"> ▪ The SFP transceivers connect fiber-optic cables to host ports and drive ports. ▪ Four or eight SFP transceivers are included with the controller-drive tray; one for each of the host channel ports on the controllers. ▪ Depending on your connection requirements, you might need to purchase additional SFP transceivers (two SFP transceivers for each fiber-optic cable). ▪ You must purchase <i>only</i> Restriction of Hazardous Substances (RoHS)-compliant SFP transceivers. |  |
| | <p>Fiber-optic InfiniBand cables (optional) – Use for FC connections to hosts.</p> | |
|  | <p>Ethernet cable This cable is used for out-of-band storage array management. For information about out-of-band storage array management, see the description for "Deciding on the Management Method" in <i>Initial Configuration and Software Installation</i> electronic document topics or the PDF on the SANtricity ES Storage Manager Installation DVD.</p> | |
|  | <p>SAS cables If you install a drive tray, you must use SAS cables to connect the controller-drive tray to the drive tray.</p> | |
|  | <p>InfiniBand Cable Use these cables for InfiniBand connections to hosts with the optional host interface card.</p> | |
|  | <p>Serial cable This cable is used for support only. You do not need to connect it during initial installation.</p> | |

Product DVDs

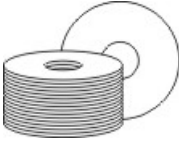

Product DVDs

| | Item | Included with the Controller-Drive Tray |
|---|---|---|
|  | <p>Firmware DVD</p> <ul style="list-style-type: none"> Firmware is already installed on the controllers. The files on the DVD are backup copies. <p>SANtricity ES Storage Manager Installation DVD</p> <ul style="list-style-type: none"> SANtricity ES Storage Manager software and documentation. To access product documentation, use the documentation map file, <code>doc_launcher.html</code>, which is located in the <code>docs</code> directory. | ✓ |

Tools and Other Items

Tools and Other Items

| | Item | Included with the Tray |
|---|--|------------------------|
| | <p>Labels</p> <p>Help you to identify cable connections and lets you more easily trace cables from one tray to another</p> | |
| | <p>A cart</p> <p>Holds the tray and components</p> | |
| | <p>A mechanical lift (optional)</p> | |
|  | <p>A Phillips screwdriver</p> | |

| | Item | Included with the Tray |
|--|--------------------------|------------------------|
|  | A flat-blade screwdriver | |
|  | Anti-static protection | |
| | A flashlight | |
| <p>Use the Compatibility Matrix, at the following website, to obtain the latest hardware compatibility information. http://www.lsi.com/compatibilitymatrix/</p> | | |

Things to Know – Cables and SFP Transceivers

The figures in this topic display the fiber-optic cables, copper cables, InfiniBand cables, SFP transceivers, and SAS cables with a SFF-8088 Connector.

 **NOTE** Your SFP transceivers and cables might look slightly different from the ones shown. The differences do not affect the performance of the SFP transceivers.

The CE5400 controller-drive trays support Fibre Channel and InfiniBand host connections and SAS drive connections. FC host connections operate at 8 Gb/s. Ports for 8-Gb/s Fibre Channel host connections require SFP transceivers designed for this data rate. These SFP transceivers look similar to other SFP transceivers but are not compatible with other types of connections.

 **WARNING (W03) Risk of exposure to laser radiation** – Do not disassemble or remove any part of a Small Form-factor Pluggable (SFP) transceiver because you might be exposed to laser radiation.

Fiber-Optic Cable Connection

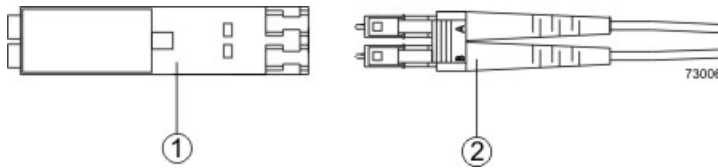

1. Active SFP Transceiver
2. Fiber-Optic Cable

Copper Fibre Channel Cable Connection

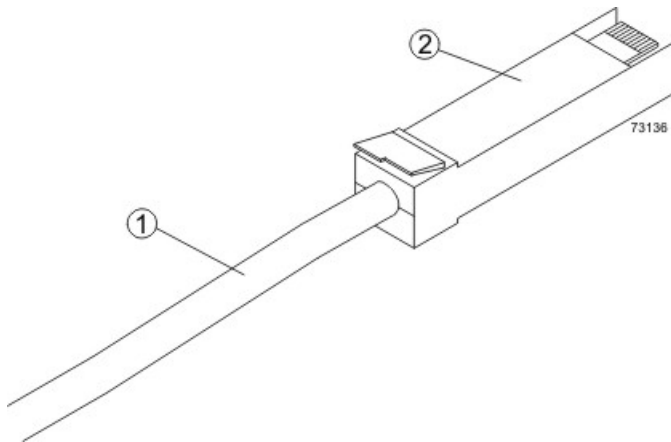

1. Copper Fibre Channel Cable
2. Passive SFP Transceiver

Host connections with InfiniBand require a fiber-optic cable with InfiniBand connectors as shown in the following figure. Connections using InfiniBand do not require SFP transceivers.

InfiniBand Cable with Built-In Connectors

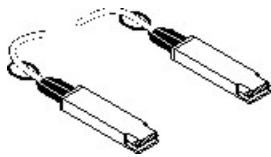

SAS Cable Connection

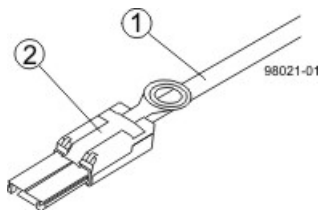

1. SAS Cable
2. SFF-8088 Connector

Things to Know – Taking a Quick Glance at the Hardware in CE5400 Controller-Drive Tray Configurations

The CE5400-24 controller-drive tray and the CE5400-12 controller-drive tray are available with optional DC power.



WARNING (W14) Risk of bodily injury – A qualified service person is required to make the DC power connection according to NEC and CEC guidelines.



CAUTION (C05) Electrical grounding hazard – This equipment is designed to permit the connection of the DC supply circuit to the earthing conductor at the equipment.



NOTE Each tray in the storage array must have a minimum of two drives for proper operation. If the tray has fewer than two drives, a power supply error is reported.

- The top of the controller-drive tray is the side with labels.
- The configuration of the host ports might appear different on your system depending on which host interface card configuration is installed.

CE5400-12 Controller-Drive Tray – Front View

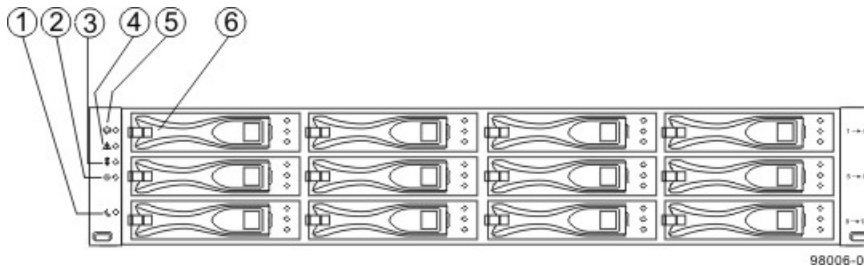

1. Standby Power LED
2. Power LED
3. Over-Temperature LED
4. Service Action Required LED
5. Locate LED
6. Drive Canister

CE5400-24 Controller-Drive Tray – Front View

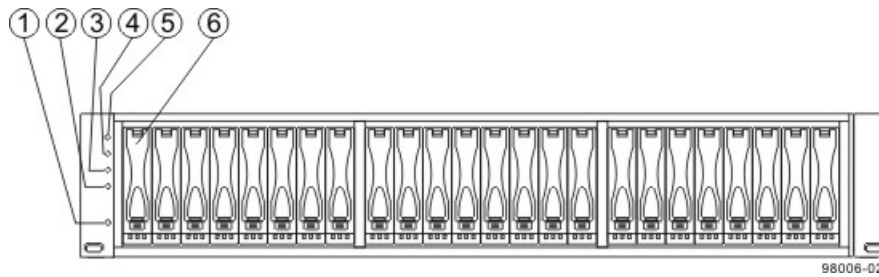

1. Standby Power LED
2. Power LED
3. Over-Temperature LED
4. Service Action Required LED
5. Locate LED
6. Drive Canister

CE5400-60 Controller-Drive Tray – Front View

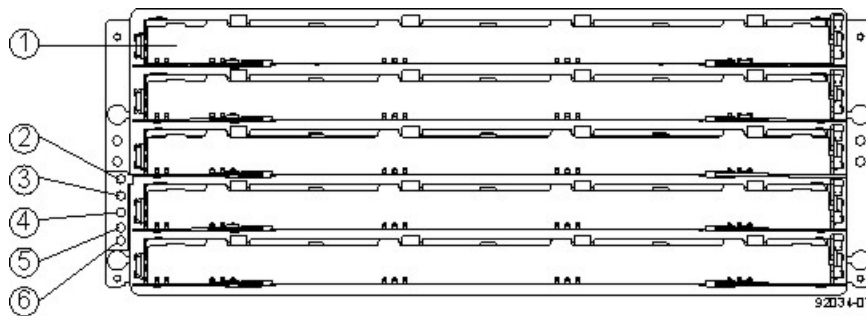

1. Drive Drawer
2. Locate LED
3. Service Action Required LED
4. Over-Temperature LED
5. Power LED
6. Standby Power LED

CE5400-12 Controller-Drive Tray and CE5400-24 Controller-Drive Tray– Rear View

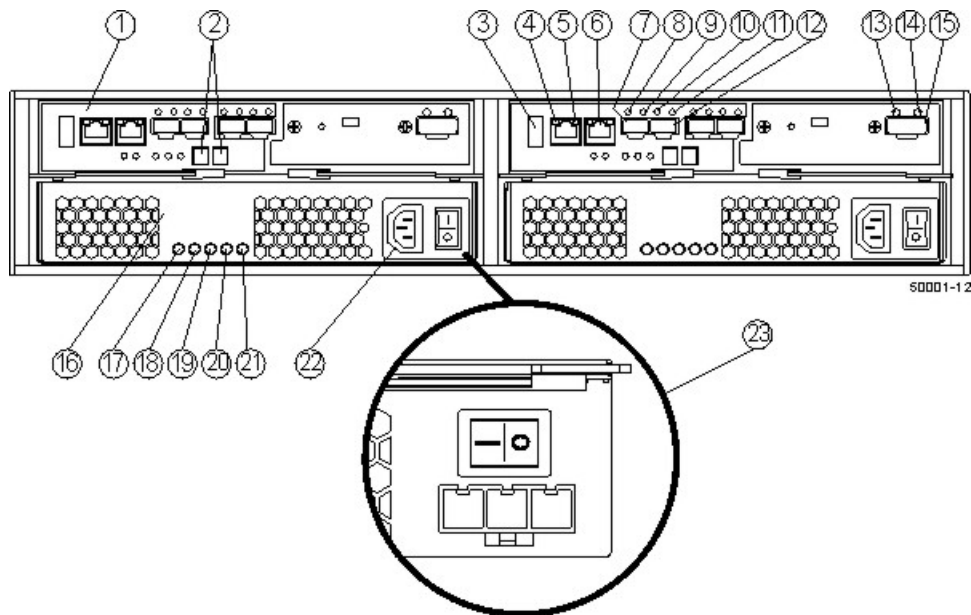

1. Controller A Canister
2. Seven-Segment Display
3. USB Connector
4. Ethernet Link Active LED
5. Ethernet Link Rate LED
6. Ethernet Connector 2
7. Fibre Channel Connector 1
8. Fibre Channel Link 1 Up LED
9. Fibre Channel Link 1 Active LED
10. Fibre Channel Connector 2
11. Fibre Channel Link 2 Up LED
12. Fibre Channel Link 2 Active LED
13. Expansion SFF-8088 Connector
14. Expansion Fault LED
15. Expansion Active LED
16. Power-Fan Canister
17. Standby Power LED
18. Power-Fan DC Power LED
19. Power-Fan Service Action Allowed LED
20. Power-Fan Service Action Required LED
21. Power-Fan AC Power LED
22. Power-Fan AC Power Connector and Switch
23. Power-Fan DC Power Connector and Switch

CE5400-60 Controller-Drive Tray – Rear View

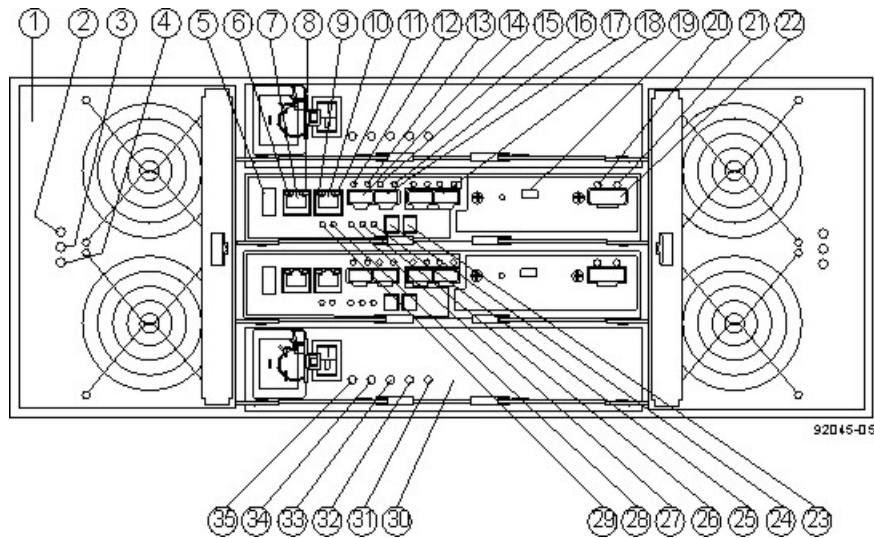

1. Fan Canister
2. Fan Power LED
3. Fan Service Action Required LED
4. Fan Service Action Allowed LED
5. USB Connector
6. Ethernet Link 1 Active LED
7. Ethernet Connector 1
8. Ethernet Link 1 Rate LED
9. Ethernet Link 2 Active LED
10. Ethernet Connector 2
11. Ethernet Link 2 Rate LED
12. Fibre Channel Link 1 Up LED
13. Fibre Channel Link 1 Active LED
14. Fibre Channel Connector 1
15. Fibre Channel Link 2 Up LED
16. Fibre Channel Link 2 Active LED
17. Fibre Channel Connector 2
18. Fibre Channel Connector 4
19. Mini USB Connector
20. Expansion Fault LED
21. Expansion Active LED
22. Expansion SFF-8088 Port Connector
23. Second Seven-Segment Display Field
24. First Seven-Segment Display Field
25. Cache Active LED
26. Controller A Service Action Required LED
27. Controller A Service Action Allowed LED
28. Battery Charging LED
29. Battery Service Action Required LED
30. Power Canister
31. Power Canister AC Power LED
32. Power Canister Service Required Allowed LED
33. Power Canister Service Action Allowed LED
34. Power Canister DC Power LED
35. Power Canister Standby Power LED

CE5400 Right-Rear Subplate with No Host Interface Card

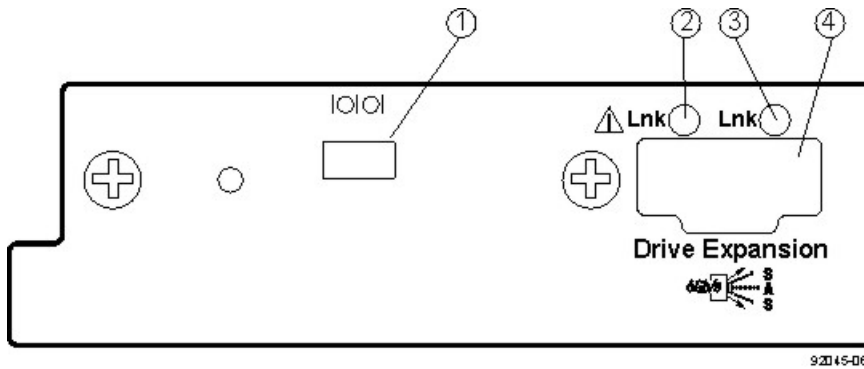

1. Mini USB
2. SAS Expansion Fault LED
3. SAS Expansion Active LED
4. SAS Expansion SFF-8088 Port Connector

CE5400 Right-Rear Subplate with an FC Host Interface Card

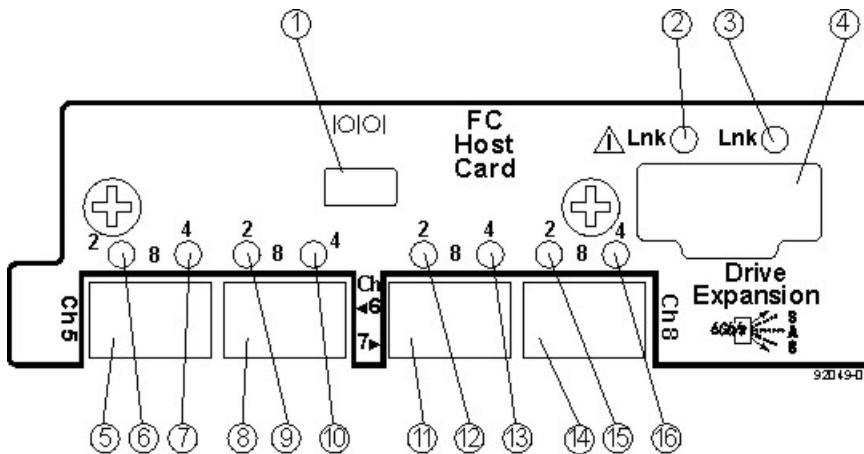

1. Mini USB
2. SAS Expansion Fault LED
3. SAS Expansion Active LED
4. SAS Expansion SFF-8088 Port Connector
5. FC Host Interface Card Connector 5
6. Host Interface Card Link 5 LED 0
7. Host Interface Card Link 5 LED 1
8. FC Host Interface Card Connector 6
9. Host Interface Card Link 6 LED 0
10. Host Interface Card Link 6 LED 1
11. FC Host Interface Card Connector 7
12. Host Interface Card Link 7 LED 0
13. Host Interface Card Link 7 LED 1
14. FC Host Interface Card Connector 8
15. Host Interface Card Link 8 LED 0
16. Host Interface Card Link 8 LED 1

CE5400 Right-Rear Subplate with an InfiniBand Host Interface Card

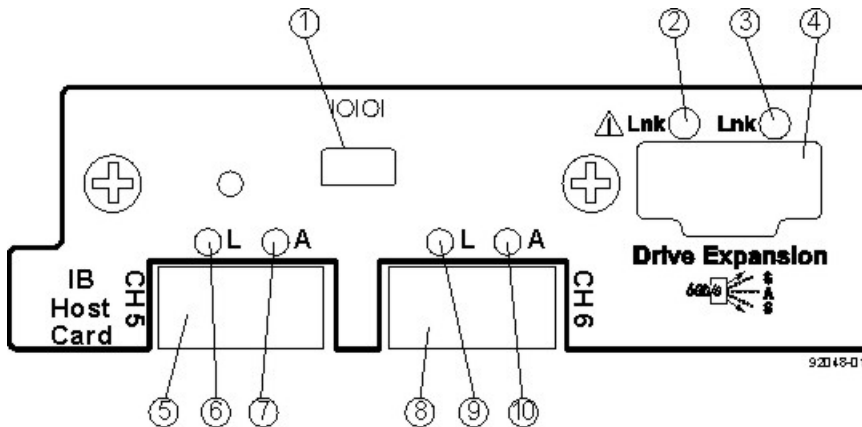

1. Mini USB
2. SAS Expansion Fault LED
3. SAS Expansion Active LED
4. SAS Expansion SFF-8088 Port Connector
5. IB Host Interface Card Connector 1
6. IB Host Interface Card Physical Link 1 LED (Green)
7. IB Host Interface Card Logical Link 1 LED (Amber)
8. IB Host Interface Card Connector 2
9. IB Host Interface Card Physical Link 2 LED (Green)
10. IB Host Interface Card Logical Link 2 LED (Amber)

⚠ ATTENTION Possible equipment damage – You must use the supported drives in the drive tray to ensure proper performance. For information about supported drives, contact your Customer and Technical Support representative.

⚠ ATTENTION Risk of equipment malfunction – To avoid exceeding the functional and environmental limits, install only drives that have been provided or approved by the original manufacturer. Not all controller-drive trays are shipped with pre-populated drives. System integrators, resellers, system administrators, or users of the controller-drive tray can install the drives.

DE1600 Drive Tray – Front View

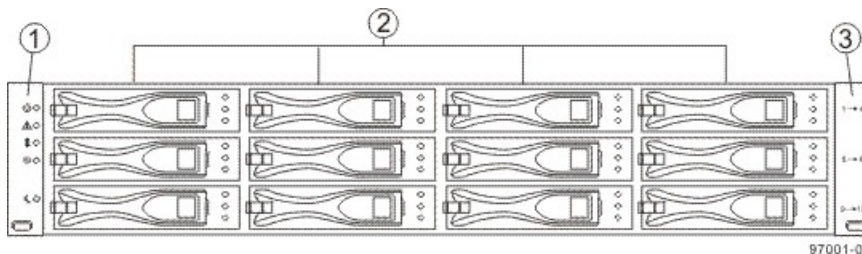

1. Left End Cap (Has the Drive Tray LEDs)
2. Drives
3. Right End Cap

DE5600 Drive Tray – Front View

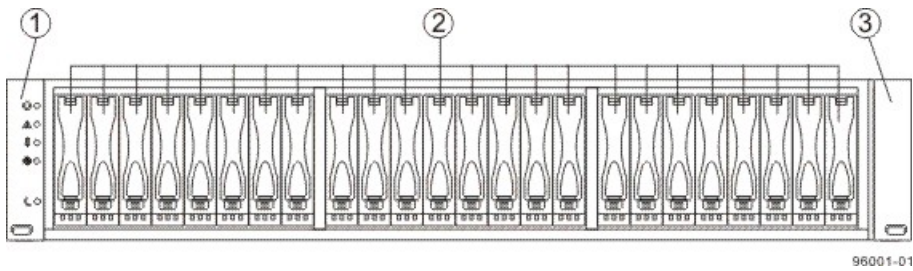

1. Left End Cap (Has the Drive Tray LEDs)
2. Drives
3. Right End Cap

DE6600 Drive Tray – Front View with the Bezel

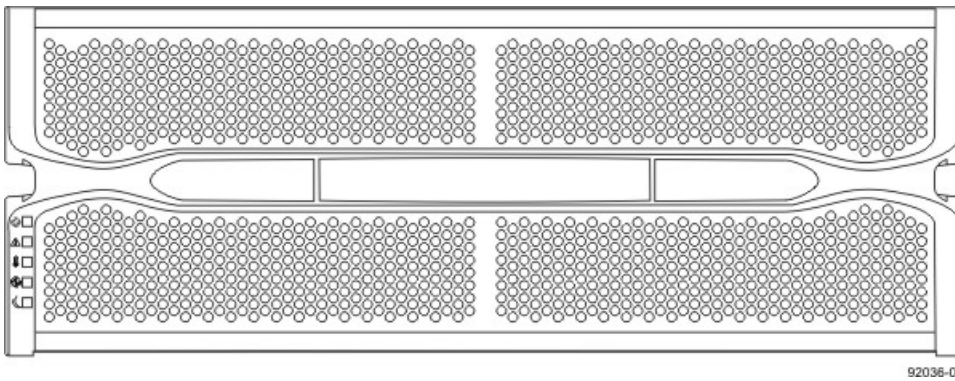

DE6600 Drive Tray – Front View with the Bezel Removed

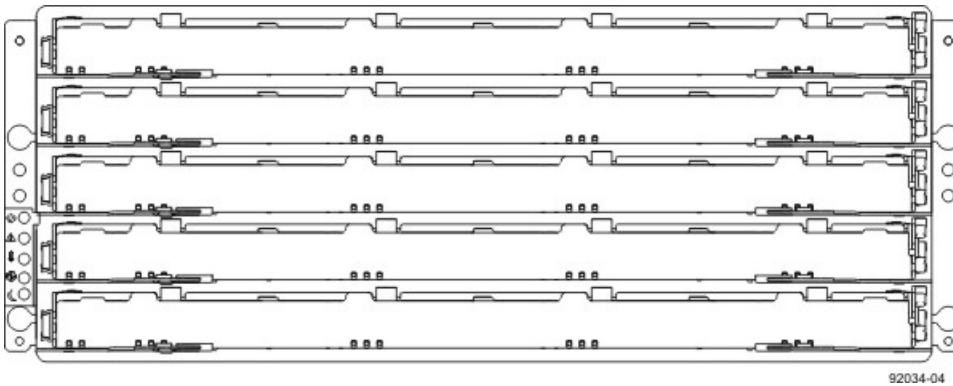

DE1600 Drive Tray or DE5600 Drive Tray with AC Power Option – Rear View

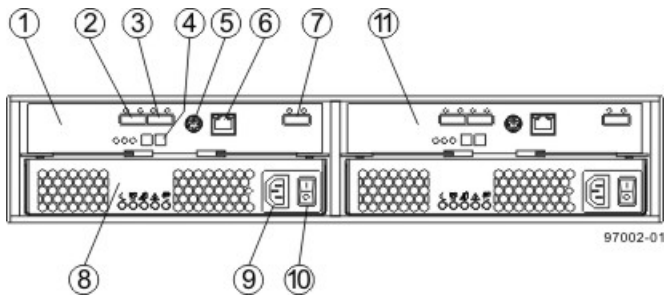

1. ESM A Canister
2. Host Connector 1
3. Host Connector 2
4. Seven-Segment Display Indicators
5. Serial Connector
6. Ethernet Connector
7. Expansion Port SFF-8088 Connector
8. Power-Fan Canister
9. Power Connector
10. Power Switch
11. ESM B Canister

DE6600 Drive Tray – Rear View

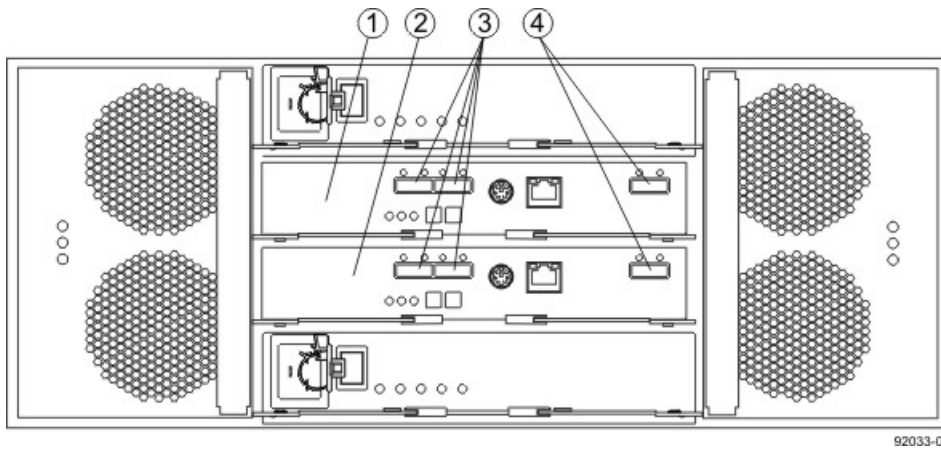

1. ESM A
2. ESM B
3. SAS IN Connectors
4. SAS Expansion Connectors

DE1600 Drive Tray or DE5600 Drive Tray with DC Power Option – Rear View

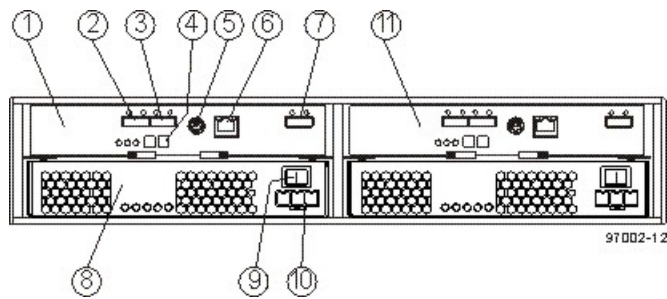

1. ESM A Canister
2. Host Connector 1
3. Host Connector 2
4. Seven-Segment Display Indicators
5. Serial Connector
6. Ethernet Connector
7. Expansion Port SFF-8088 Connector
8. Power-Fan Canister
9. Power Connector
10. Power Switch
11. ESM B Canister

You can order an optional DC power supply connection and connector cables for the drive tray. **A qualified service person is required to make the DC power connection per NEC and CEC guidelines.** A two-pole 30-amp circuit breaker is required between the DC power source and the drive tray for over-current and short-circuit protection. Before turning off any power switches on a DC-powered drive tray, you must disconnect the two-pole 30-amp circuit breaker.

⚠ WARNING (W12) Risk of electrical shock – This unit has more than one power source. To remove all power from the unit, all DC MAINS must be disconnected by removing all power connectors (item 4 below) from the power supplies.

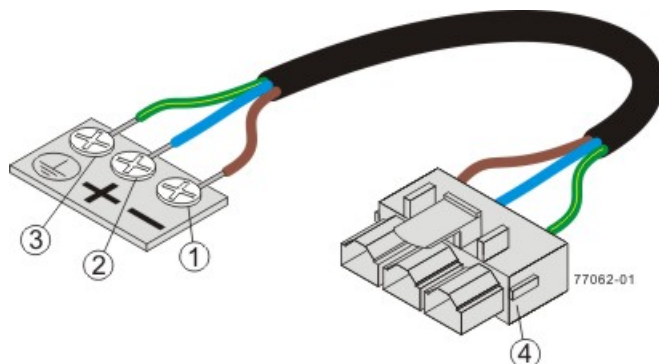

1. Supply (Negative), Brown Wire, -48 VDC
2. Return (Positive), Blue Wire
3. Ground, Green/Yellow Wire
4. DC Power Connector

For Additional Information on the CE5400 Controller-Drive Tray Configuration

Refer to the *Storage System Site Preparation Guide* on the SANtricity ES Storage Manager Installation DVD for information about the installation requirements of the various CE5400 storage array components.

Step 2 – Installing and Configuring the Switches

Things to Know – Switches



NOTE Most of the switches, as shipped from the vendor, require an update to their firmware to work correctly with the storage array.

Depending on the configuration of your storage array, you might use Fibre Channel switches or InfiniBand switches.

The switches in the following table are certified for use with a CE5400 storage array.

Supported Fibre Channel Switches

| Vendor | Model | Data Rate |
|---------|------------|-----------|
| Brocade | 200E | 4Gb |
| | 4100 | 4Gb |
| | 48000 | 4Gb |
| | 5000 | 4Gb |
| | 300 | 8Gb |
| | 5100 | 8Gb |
| | 5300 | 8Gb |
| | DCX | 8Gb |
| Cisco | 9506 | 2Gb, 4Gb |
| | 9509 | 4Gb |
| | 9216 | 2Gb, 4Gb |
| | 9216i | 4Gb |
| | 9120 | 4Gb |
| | 914x | 4Gb |
| | 9513 | 4Gb, 8Gb |
| | 9020 | Yes |
| | MDS9000 | Yes |
| | 9222i | 4Gb, 8Gb |
| | 9134 | 4Gb |
| QLogic | SANbox5200 | 4Gb |

| Vendor | Model | Data Rate |
|--------|------------|-----------|
| | SANbox3600 | 4Gb |
| | SANbox3800 | 8Gb |
| | SANbox5600 | 4Gb |
| | SANbox5800 | 8Gb |
| | SANbox9000 | 8Gb |

Supported InfiniBand Switches

| Vendor | Model |
|----------|---------------|
| QLogic | 12300 |
| | 12800 |
| Voltaire | 4036 |
| | 4200/4700 |
| Mellanox | IS5000 family |

If required, make the appropriate configuration changes for *each* switch that is connected to the storage array.

Refer to the switch's documentation for information about how to install the switch and how to use the configuration utilities that are supplied with the switch.

Procedure – Installing and Configuring Switches

1. Install your switch according to the vendor's documentation.
2. Use the Compatibility Matrix at the website <http://www.lsi.com/compatibilitymatrix/> to obtain this information:
 - The latest hardware compatibility information
 - The models of the switches that are supported
 - The firmware requirements and the software requirements for the switches
3. Update the switch's firmware by accessing it from the applicable switch vendor's website.
This update might require that you cycle power to the switch.
4. Find your switch in the following table to see whether you need to make further configuration changes. Use your switch's configuration utility to make the changes.

Supported Switch Vendors and Required Configuration Changes

| Switch Vendor | Configuration Changes Required? |
|---------------|---|
| Brocade | Yes Change the In-Order Delivery (IOD) option to ON. |

| Switch Vendor | Configuration Changes Required? |
|---------------|---|
| Cisco | Yes Change the In-Order Delivery (IOD) option to ON. |
| QLogic | No |

5. Make any necessary changes, and then continue with the tasks in [Step 3 – Installing the Host Bus Adaptors for the CE5400 Controller-Drive Trays](#).

Step 3 – Installing the Host Bus Adapters for the CE5400 Controller-Drive Trays

Key Terms

HBA host port

The physical and electrical interface on the host bus adapter (HBA) that provides for the connection between the host and the controller. Most HBAs will have either one or two host ports. The HBA has a unique World Wide Identifier (WWID) and each HBA host port has a unique WWID.

HBA host port world wide name

A 16-character unique name that is provided for each port on the host bus adapter (HBA).

host bus adapter (HBA)

A physical board that resides in the host. The HBA provides for data transfer between the host and the controllers in the storage array over the I/O host interface. Each HBA contains one or more physical ports.

Things to Know – Host Bus Adapters

- The CE5400 controller-drive trays supports four 8-Gb/s Fibre Channel host connections and optional host interface cards (HICs) for an additional four 8-Gb/s Fibre Channel host connections or two 40-Gb/s InfiniBand host connections. The HBAs on a host must support the type of port (Fibre Channel or InfiniBand) to which they connect on the controller-drive tray. Do not mix Fibre Channel or InfiniBand connections to one controller-drive tray; use either one or the other. For the best performance, HBAs should support the highest data rate supported by the HICs to which they connect.
- For maximum hardware redundancy, you must install a minimum of two HBAs in each host. Using both ports of a dual-port HBA provides two paths to the storage array but does not ensure redundancy if an HBA fails.



NOTE You can use the Compatibility Matrix to obtain information about the supported models of the HBAs and their requirements. Go to <http://www.lsi.com/compatibilitymatrix/>, and select the desired Developer Partner Program link. Check its Compatibility Matrix to make sure you have an acceptable configuration.

- Most of the HBAs, as shipped from the vendor, require updated firmware and software drivers to work correctly with the storage array. For information about the updates, refer to the website of the HBA vendor.

Procedure – Installing Host Bus Adapters

1. Go to <http://www.lsi.com/compatibilitymatrix/>, and select the desired Developer Partner Program link. Check its Compatibility Matrix to make sure you have an acceptable configuration.

The Compatibility Matrix provides this information:

- The latest hardware compatibility information
- The models of the HBAs that are supported
- The firmware requirements and the software requirements for the HBAs

2. Install your HBA according to the vendor documentation.



NOTE If your operating system is Windows Server 2008 Server Core, you might have additional installation requirements. Refer to the Microsoft Developers Network (MSDN) for more information about Windows Server 2008 Server Core. You can access these resources from www.microsoft.com.

3. Install the latest version of the firmware for the HBA. You can find the latest version of the firmware for the HBA at the HBA vendor website.



NOTE The remaining steps are general steps to obtain the HBA host port world wide name from the HBA BIOS utility. If you have installed the host context agent on all of your hosts, you do not need to perform these steps. If you are performing these steps, the actual prompts and screens vary depending on the vendor that provides the HBA. Also, some HBAs have software utilities that you can use to obtain the world wide name for the port instead of using the BIOS utility.

4. Reboot or start your host.
5. While your host is booting, look for the prompt to access the HBA BIOS utility.
6. Select each HBA to view its HBA host port world wide name.
7. Record the following information for each host and for each HBA connected to the storage array:
 - The name of each host
 - The HBAs in each host
 - The HBA host port world wide name of each port on the HBA

The following table shows examples of the host and HBA information that you must record.

Examples of HBA Host Port World Wide Names

| Host Name | Associated HBAs | HBA Host Port World Wide Name |
|----------------|---------------------------------|--|
| ICTENGINEERING | Vendor x, Model y (dual port) | 37:38:39:30:31:32:33:32 37:38:39:30:31:32:33:33 |
| | Vendor a, Model y (dual port) | 42:38:39:30:31:32:33:42 42:38:39:30:31:32:33:44 |
| ICTFINANCE | Vendor a, Model b (single port) | 57:38:39:30:31:32:33:52 |
| | Vendor x, Model b (single port) | 57:38:39:30:31:32:33:53 |

Step 4 – Installing the CE5400 Controller-Drive Tray

Things to Know – General Installation

The power supplies meet standard voltage requirements for both domestic and worldwide operation.

 **NOTE** Make sure that the combined power requirements of your trays do not exceed the power capacity of your cabinet.

Procedure – Installing the CE5400-24 Controller-Drive Tray or the CE5400-12 Controller-Drive Tray

Use this procedure to install a CE5400-24 controller-drive tray or a CE5400-12 controller-drive tray in a cabinet. To install a CE5400-60 controller-drive tray, see [Procedure – Installing the CE5400-60 Controller-Drive Tray](#).

CE5400-24 Controller-Drive Tray Airflow Direction and Clearance Requirements

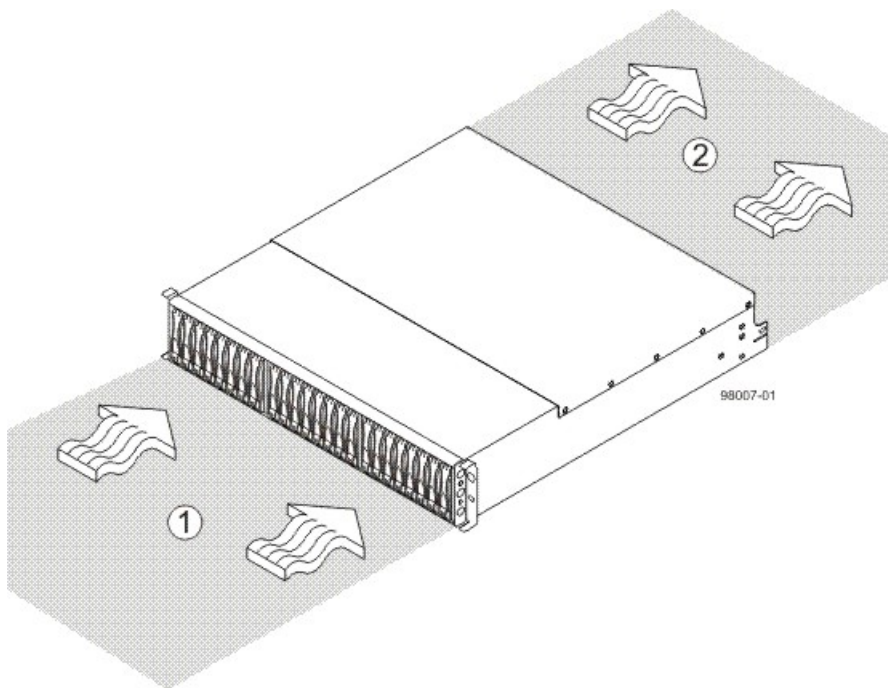

1. 76-cm (30-in.) clearance in front of the cabinet
2. 61-cm (24-in.) clearance behind the cabinet

CE5400-12 Controller-Drive Tray Airflow Direction and Clearance Requirements

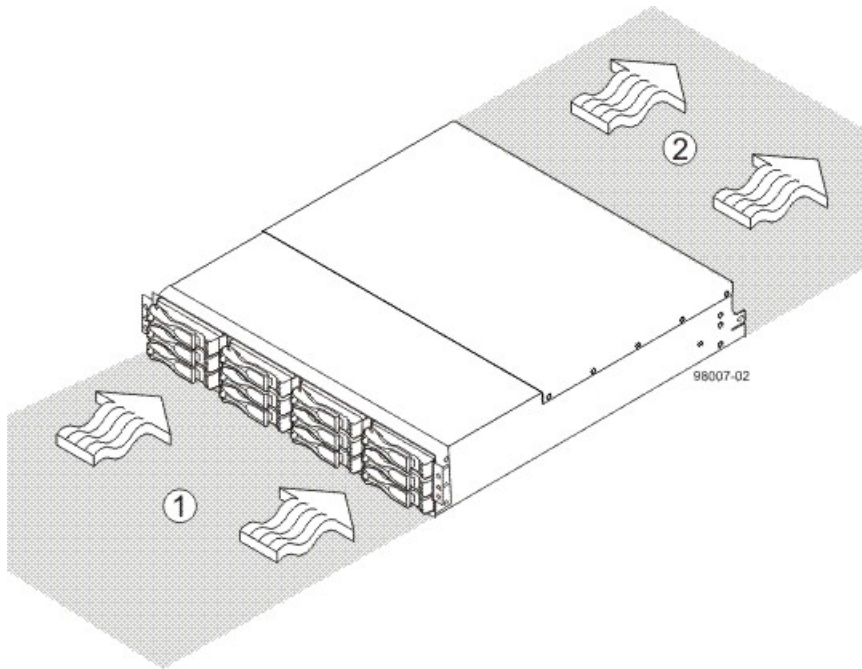

1. 76-cm (30-in.) clearance in front of the cabinet
2. 61-cm (24-in.) clearance behind the cabinet

WARNING (W08) Risk of bodily injury –



>18 kg (39.7 lbs)

Two persons are required to safely lift the component.

1. Make sure that the cabinet is in the final location. Make sure that the cabinet installation site meets the applicable clearance requirements as shown in the preceding figures.
2. Lower the feet on the cabinet, if required, to keep it from moving.
3. Install the mounting rails in the cabinet. For more information, refer to the installation instructions that are included with your mounting rails.
 - If you are installing the mounting rails above an existing tray, position the mounting rails directly above the existing tray.
 - If you are installing the mounting rails below an existing tray, allow 17.8-cm (7.00-in.) clearance below the existing tray.

 **ATTENTION Risk of equipment malfunction** – To avoid exceeding the functional and environmental limits, install only drives that have been provided or approved by the original manufacturer. Not all controller-drive trays are shipped with pre-populated drives. System integrators, resellers, system administrators, or users of the controller-drive tray can install the drives.

 **NOTE** Make sure that you place the controller-drive tray in the middle portion of the cabinet while allowing room for drive trays to be placed above and below the controller-drive tray. As you add drive trays, position them below and above the controller-drive tray, alternating so that the cabinet does not become top heavy.

4. With the help of one other person, slide the rear of the controller-drive tray onto the mounting rails. Make sure that the top mounting holes on the controller-drive tray align with the mounting rail holes of the cabinet (see the following two figures for the location of screws and mounting holes).

The rear of the controller-drive tray slides into the slots on the mounting rails.

Securing the CE2600-24 Controller-Drive Tray to the Cabinet

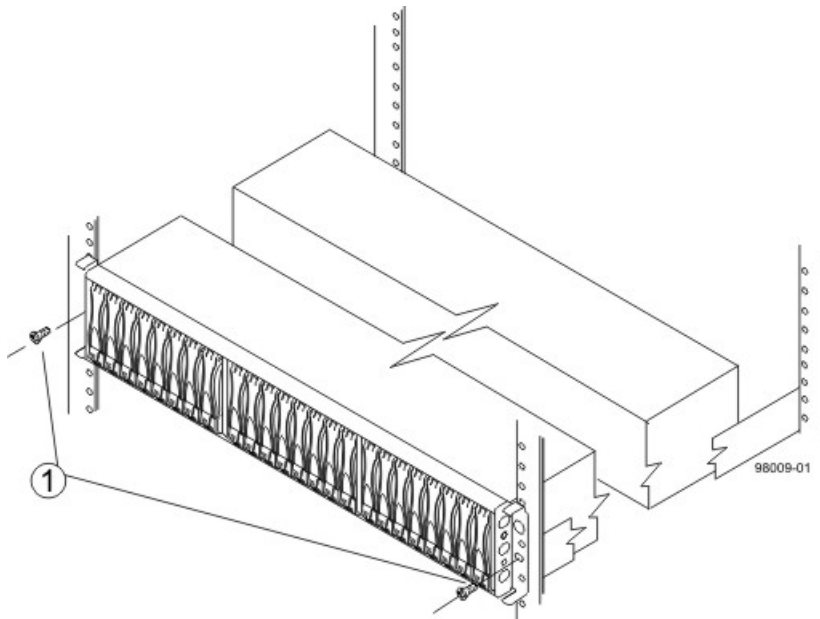

1. Screws

Securing the CE5400-12 Controller-Drive Tray to the Cabinet

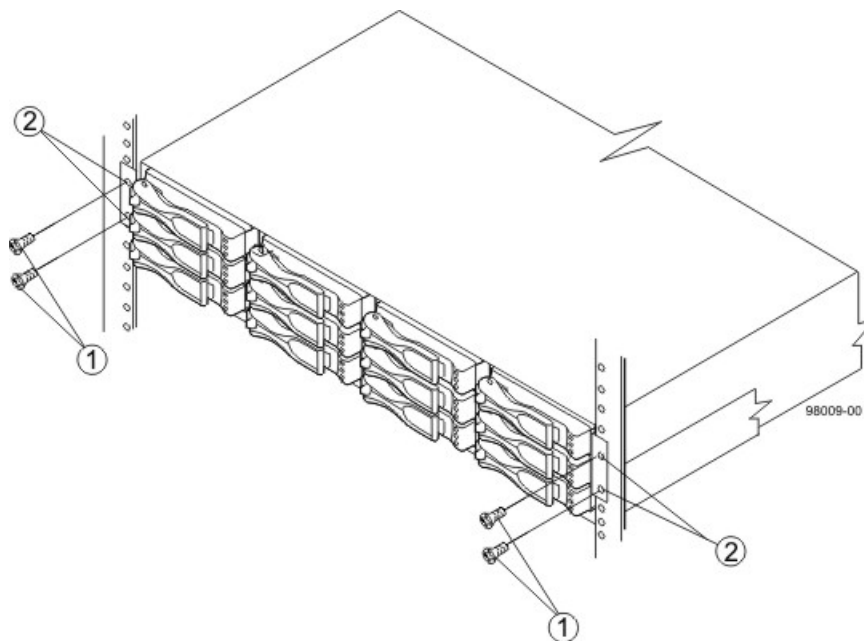

1. Screws
2. Mounting Holes



NOTE The rear of the controller-drive tray contains two controllers. The top of the controller-drive tray is the side with the labels.

5. Secure the screws in the top mounting holes and the bottom mounting holes on each side of the controller-drive tray.
6. Secure the rear of the of the controller-drive tray to the cabinet by using two screws to attach the flanges on each side at the rear of the controller-drive tray to the mounting rails.
7. Install the bezel on the front of the controller-drive tray.
8. Install the drive trays. Refer to [Step 7 – Connecting the CE5400 Controller-Drive Tray to the Drive Trays](#).

Procedure – Installing the CE5400-60 Controller-Drive Tray

You can install the CE5400-60 controller-drive tray into an Industry-standard cabinet, provided it has a depth of 100 cm (40 in.).

A minimum depth of 76 cm (30 in.) between the front EIA support rails and the rear EIA support rails is required.



NOTE If you are mounting the CE5400-60 controller-drive tray in a cabinet with square holes, use the eight shoulder washers in the rail kit to align the screws in the holes (see [step 4](#) through [step 7](#)).

1. Make sure that the cabinet is in the final location. Make sure that you meet the clearance requirements shown in the following figure.

CE5400-60 Controller-Drive Tray Airflow Direction and Clearance Requirements

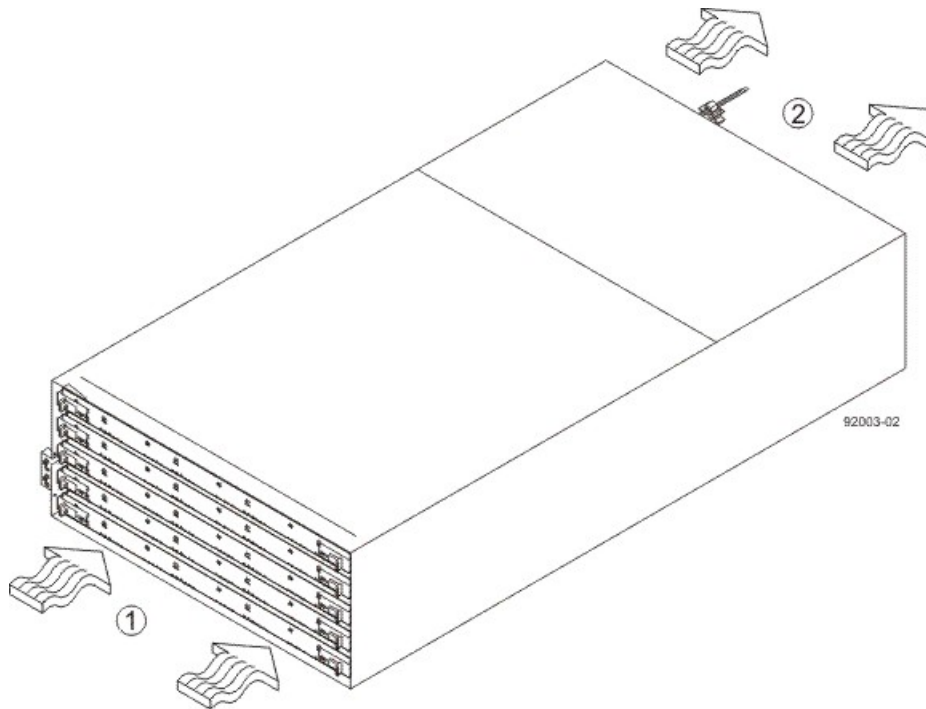

1. 81 cm (32 in.) clearance in front of the cabinet
2. 61 cm (24 in.) clearance behind the cabinet



NOTE Fans pull air through the controller-drive tray from front to back across the drives.

2. Lower the feet on the cabinet to keep the cabinet from moving.



WARNING (W09) Risk of bodily injury –



>35 kg (70.5 lbs)

Three persons are required to safely lift the component.



WARNING (W15) Risk of bodily injury – An empty tray weighs approximately 56.7 kg (125 lb). Three persons are required to safely move an empty tray. If the tray is populated with components, a mechanized lift is required to safely move the tray.

3. With the help of at least two other persons, remove the controller-drive tray and all of the contents from the shipping carton, using the four controller-drive tray handles (two to a side) as shown in the following figure. Set the controller-drive tray aside.

CE5400-60 Controller-Drive Tray with Controller-Drive Tray Handles (Two on Each Side)

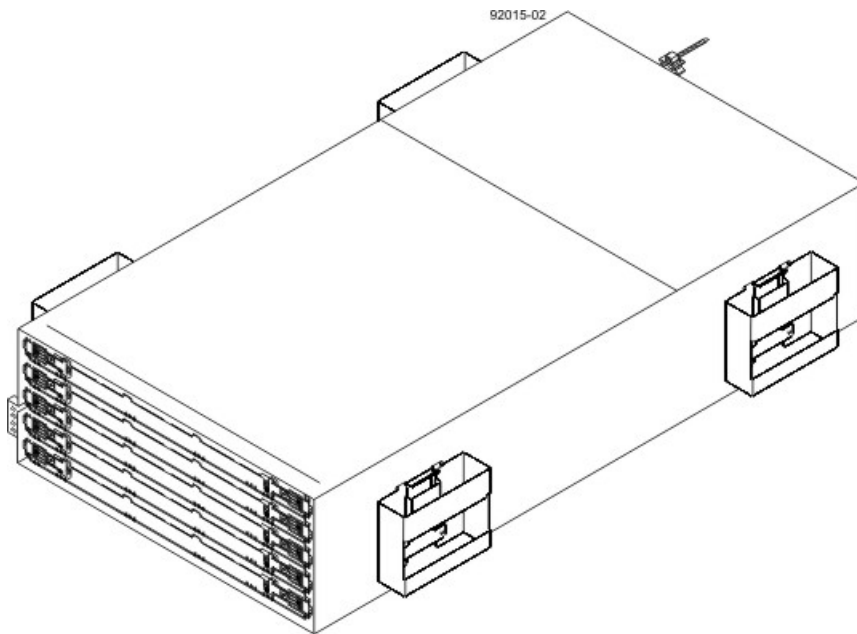

4. Position the mounting rails in the cabinet as shown in the following figure.

Positioning the Mounting Rails in the Cabinet

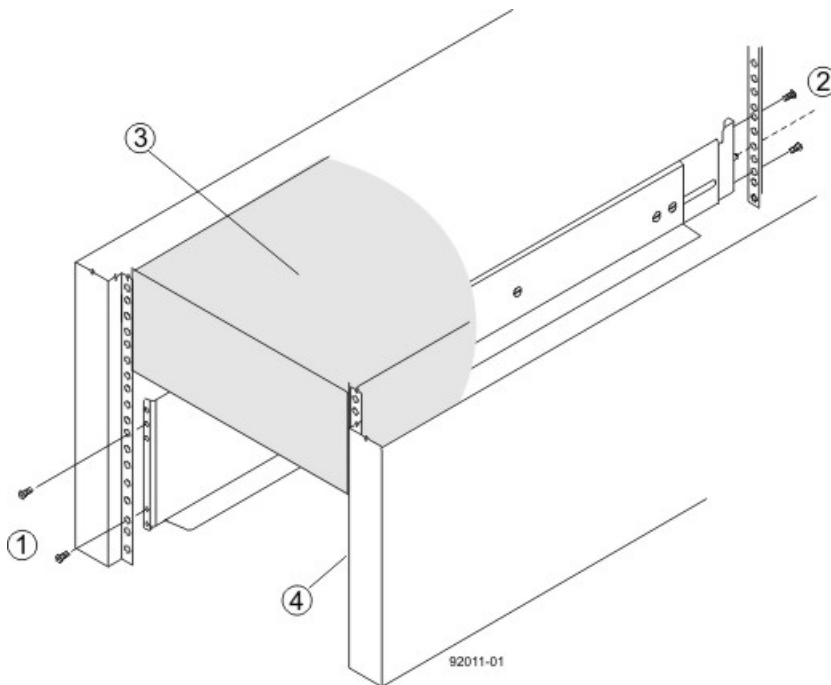

1. Screws for Securing the Mounting Rail to the Cabinet (Front)
 2. Screws for Securing the Mounting Rail to the Cabinet (Rear)
 3. Existing Tray
 4. Industry Standard Cabinet
- If you are installing the mounting rails above an existing tray, position the mounting rails directly above the tray.

- If you are installing the mounting rails below an existing tray, allow 17.8-cm (7-in.) vertical clearance for the CE5400-60 controller-drive tray.
5. To attach the mounting rails to the cabinet, and then perform one of the following actions:
 - If you are using the long, fixed-size mounting rails, go to [step 6](#).
 - If you are using the shorter adjustable mounting rails, go to [step 7](#).
 6. To attach the long, fixed-size rails to the cabinet, perform these substeps:
 - a. Make sure that the adjustment screws on the mounting rail are loose so that the mounting rail can extend or contract as needed.

Attaching the Long, Fixed-Size Mounting Rails to the Cabinet

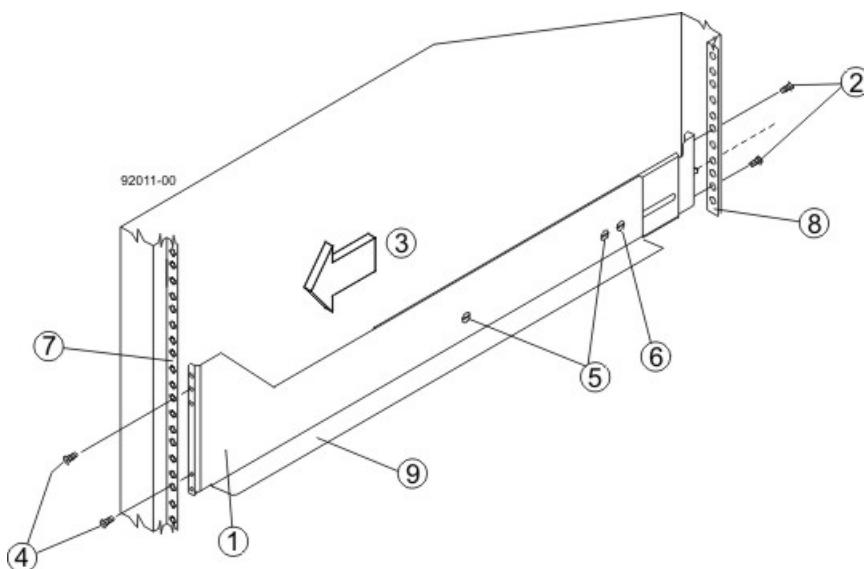

1. Front of the Mounting Rail
 2. Two M4 Screws for the Rear EIA Support Rail
 3. Front of the Cabinet
 4. Two M5 Screws for the Front EIA Support Rail
 5. Adjustment Screws
 6. Rear Hold-Down Screw
 7. Cabinet Mounting Holes on the Front EIA Support Rail
 8. Cabinet Mounting Holes on the Rear EIA Support Rail
 9. Mounting Rail Lip
- b. Remove the rear hold-down screw. It protrudes from the inside of the rail and prevents you from sliding the controller-drive tray onto the rails.
 - c. Place the mounting rail inside the cabinet, and extend the mounting rail until the flanges on the mounting rail touch the inside of the cabinet.
 - d. Insert one M5 screw through the front of the cabinet, and screw it into the top captured nut in the mounting rail.
 - e. Insert two M5 screws through the rear of the cabinet, and screw them into the captured nuts in the rear flange in the mounting rail.
 - f. Tighten the adjustment screws on the mounting rail.
 - g. Repeat substep a through substep f to install the second mounting rail.
 - h. Insert one M5 screw through the front of the mounting rail. You use this screw to attach the controller-drive tray to the cabinet.

7. To attach the shorter, adjustable size mounting rails to the cabinet, perform these sets of substeps:

Short Adjustable Mounting Rail – Left Side

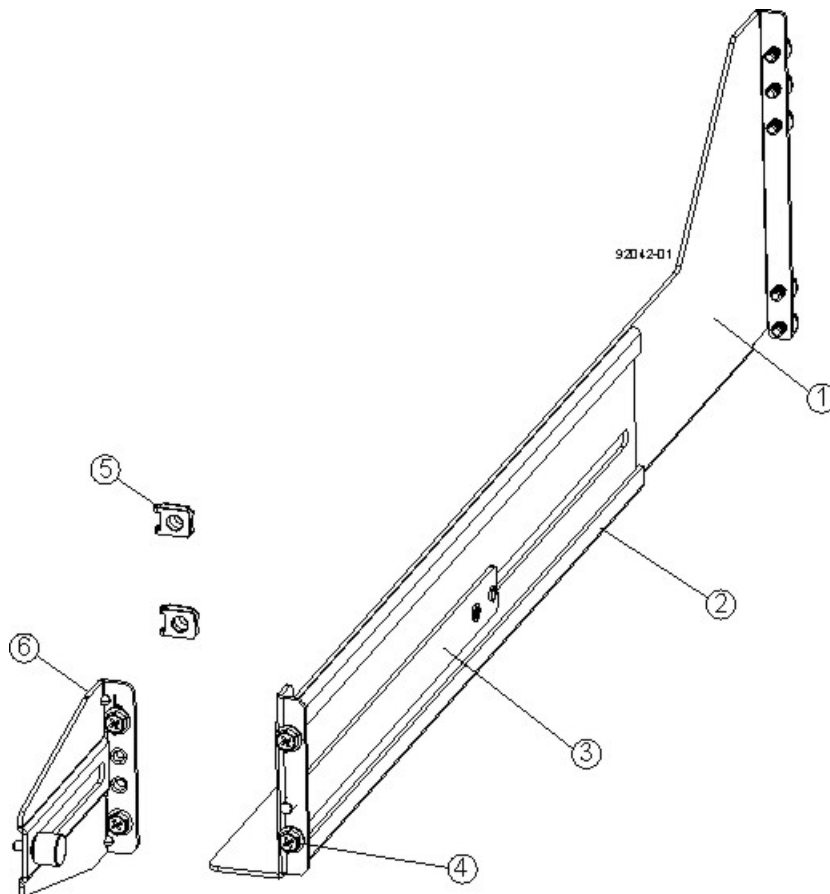

1. Front of the Mounting Rail
2. Rear of the Mounting Rail
3. Rail Fix Bar
4. Two M5 Screws for the Front EIA Support Rail
5. Two Clips for the Front EIA Support Rail
6. Rear Bracket

- a. Make sure that the adjustment screws on the mounting rail are loose so that the mounting rail can extend or contract as needed (see the figure [Short Adjustable Mounting Rail -- Left Side](#)).
- b. Place the mounting rail inside the cabinet, and extend the mounting rail until the flanges on the mounting rail touch the inside of the cabinet (see the figure [Short Adjustable Mounting Rail Attached to the Cabinet](#)).
- c. Insert one M5 screw through the front of the cabinet, and screw it into the top captured nut in the mounting rail.
- d. Insert two M4 screws through the rear of the cabinet, and screw them into the captured nuts in the rear flange in the mounting rail.
- e. Tighten the adjustment screws on the mounting rail.
- f. Repeat substep a through substep f to install the second mounting rail.
- g. Insert one M5 screw through the front of the mounting rail. This screw will attach the controller-drive tray to the cabinet.

Short Adjustable Mounting Rail Attached to the Cabinet

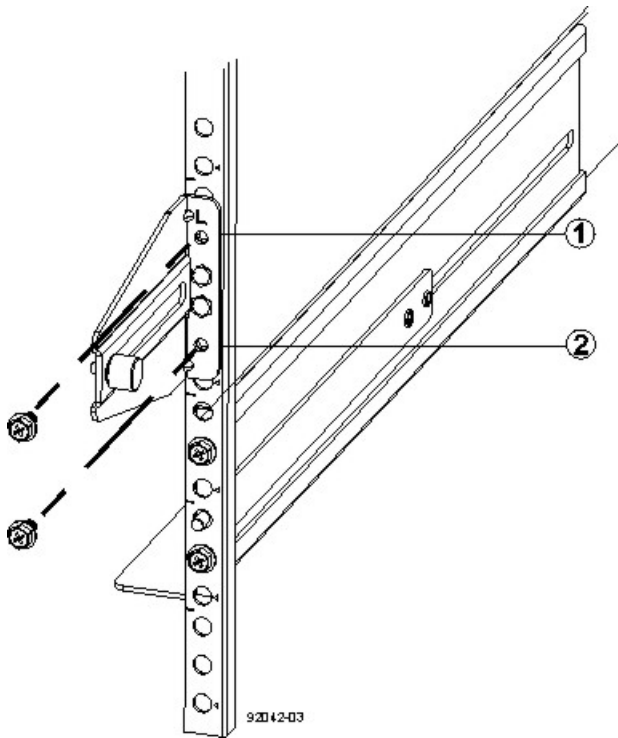

1. Top Cabinet Mounting Hole on the Rear EIA Support Rail
2. Bottom Cabinet Mounting Hole on the Rear EIA Support Rail

8. Remove the bezel from the front of the controller-drive tray.



WARNING (W15) Risk of bodily injury – An empty tray weighs approximately 56.7 kg (125 lb). Three persons are required to safely move an empty tray. If the tray is populated with components, a mechanized lift is required to safely move the tray.

9. With the help of at least two other persons, slide the rear of the controller-drive tray onto the mounting rails. The controller-drive tray is correctly aligned when the mounting holes on the front flanges of the controller-drive tray align with the mounting holes on the front of the mounting rails.
10. After the controller-drive tray is correctly aligned, remove the enclosure lift handles as shown in the figure [Removing an Enclosure Lift Handle from the Controller-Drive Tray](#):
 - a. Use your thumb to unlatch and remove the rear controller-drive tray lift handles (two to a side).
 - b. Use the front controller-drive tray lift handles to slide the drive tray all the way into the cabinet.
 - c. Once the drive tray is securely in the cabinet, use your thumb to unlatch and remove the controller-drive tray lift handles (two to a side).

Removing an Controller-Drive Tray Lift Handle from the CE5400-60 Controller-Drive Tray

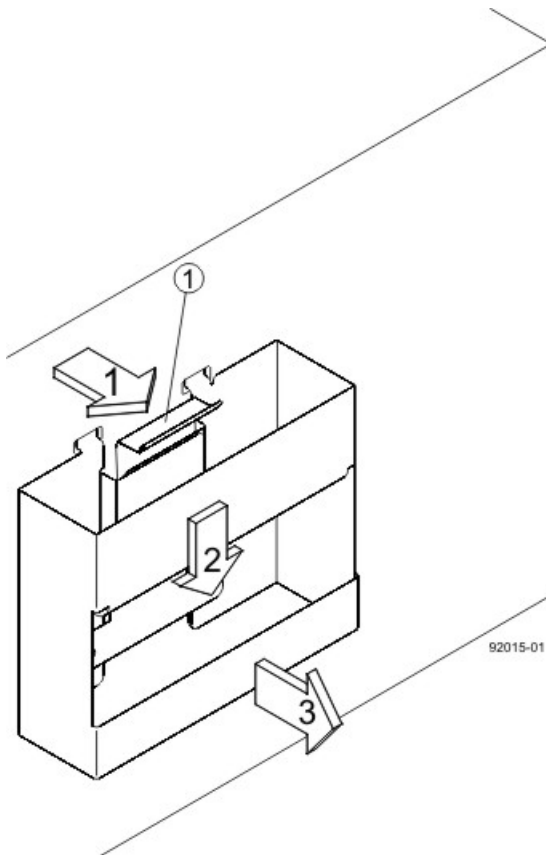

1. Pull the thumb latch away from the controller-drive tray to detach the hook.
 2. Shift the handle down to release the other four hooks.
 3. Move the handle away from the controller-drive tray.
11. Secure the front of the controller-drive tray to the cabinet. Use the four screws to attach the flange on each side of the front of the controller-drive tray to the mounting rails.
- a. Insert two M5 screws through the bottom holes of a flange on the controller-drive tray so that the screws go through the EIA support rail and engage the bottom captured nuts in the mounting rail. Tighten the screws.
 - b. Repeat substep a for the second flange.

Attaching the Front of the CE5400-60 Controller-Drive Tray

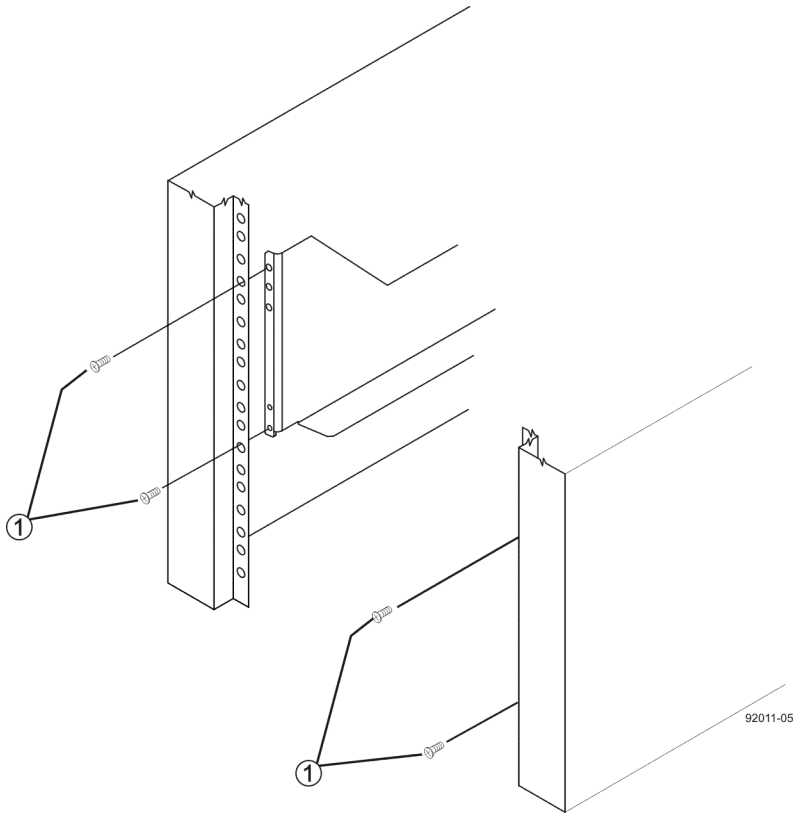

1. Four Screws for Securing the Front of the Controller-Drive Tray
12. Remove the fan canister from the controller-drive tray by pressing on the tab holding the fan canister handle in place, and then pulling the fan canister toward you.

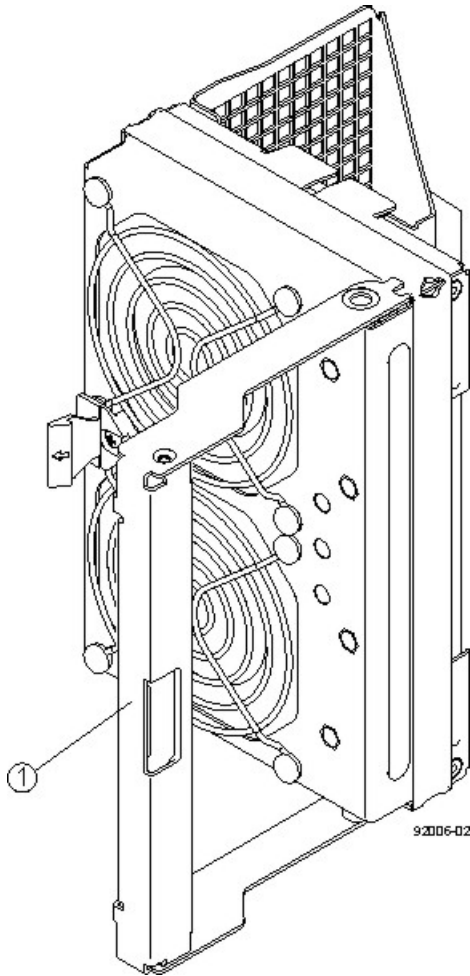

1. Fan Canister Handle

13. Use the fan canister handle to pull the fan canister out of the controller-drive tray.

14. Secure the side of the controller-drive tray to the mounting rails by performing these substeps:

Securing the Controller-Drive Tray to the Rails

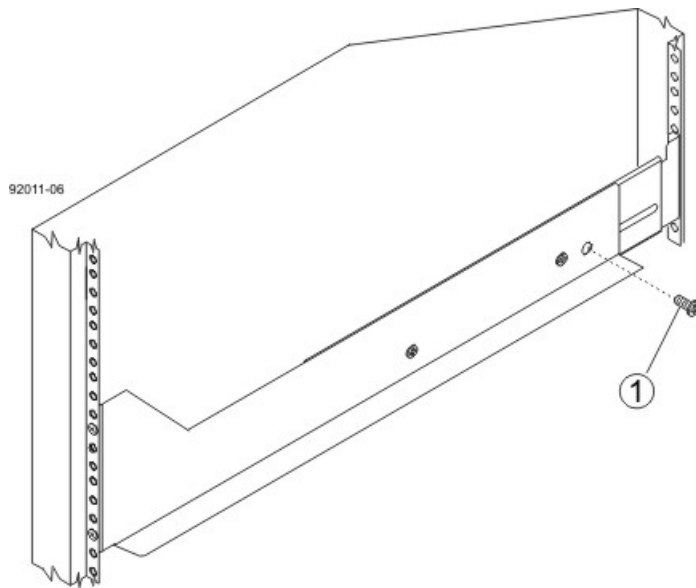

1. 10-32 Screw

- a. Insert a 10-32 screw through the side sheet metal of the controller-drive tray into the captured nut on the side of the mounting rail. Tighten the screws.
- b. Repeat substep a for the other side.



NOTE After the controller-drive tray is installed, there should be seven screws on each side (right and left) of the cabinet.



NOTE Make sure that each drive drawer in the controller-drive tray is securely fastened to ensure proper air flow to the drives.

Controller-Drive Tray Installed in the Cabinet

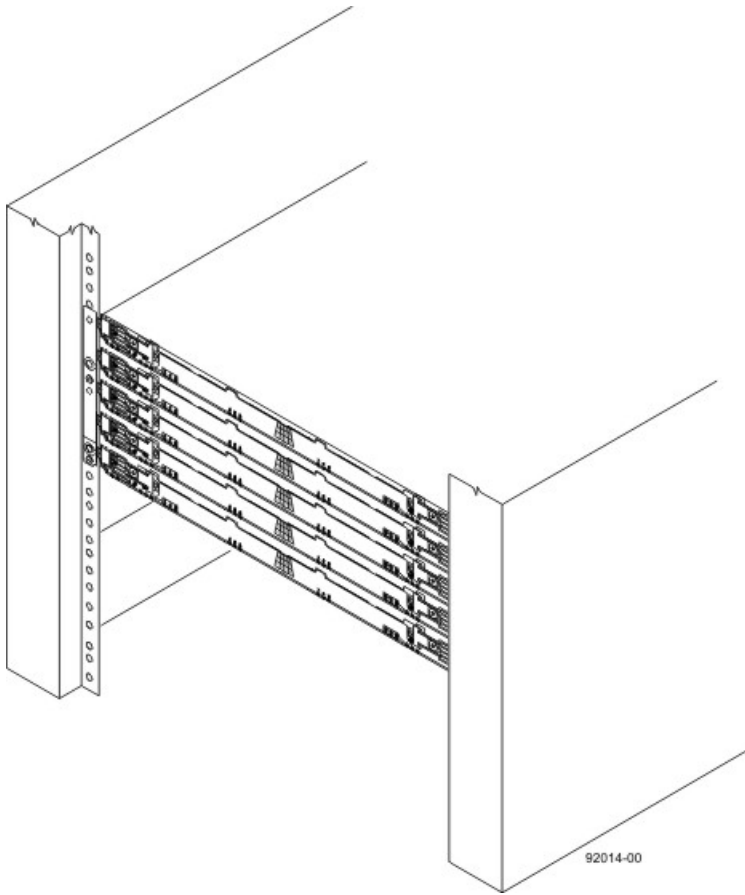

15. Slide the fan canister all the way back into the controller-drive tray until the tab on the fan canister latches.
16. Attach the bezel onto the front of the controller-drive tray.

Step 5 – Connecting the CE5400 Controller-Drive Tray to the Hosts

Key Terms

direct topology

A topology that does not use a switch.

switch topology

A topology that uses a switch.

topology

The logical layout of the components of a computer system or network and their interconnections. Topology deals with questions of what components are directly connected to other components from the standpoint of being able to communicate. It does not deal with questions of physical location of components or interconnecting cables. (The Dictionary of Storage Networking Terminology)

Things to Know – Host Channels



ATTENTION Possible hardware damage – To prevent electrostatic discharge damage to the tray, use proper antistatic protection when you handle tray components.

- Each controller in the controller-drive tray has four standard 8-Gb/s Fibre Channel host ports.
- Each controller in the controller-drive tray might have an optional host interface card (HIC). The HIC has either four additional 8-Gb/s Fibre Channel host ports or two 40-Gb/s InfiniBand host ports.



NOTE In configurations where a HIC does not exist, the space is covered with a faceplate.

- If InfiniBand host connections are used, do not use the standard Fibre Channel ports. Mixing InfiniBand and Fibre Channel host connections is not supported.

Host Channels on the CE5400-60 Controller-Drive Tray – Rear View

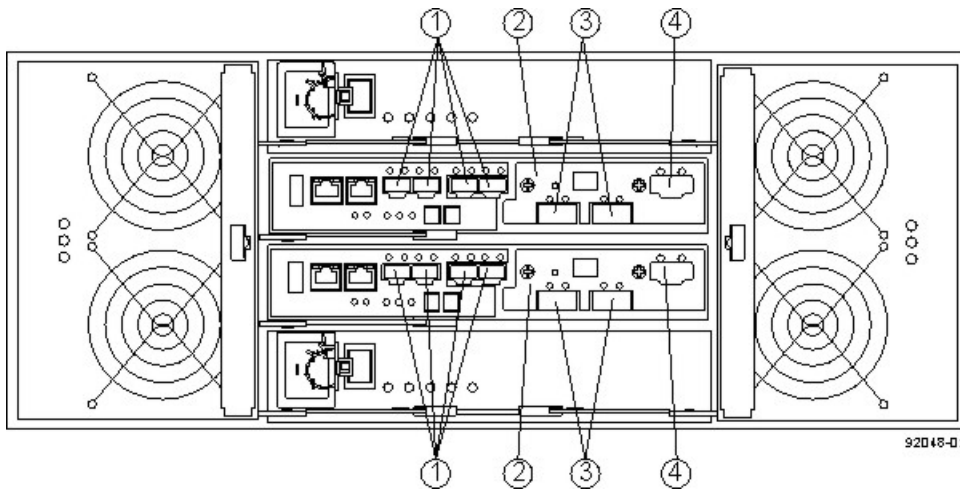

1. Standard Host Connectors
2. Host Interface Card (HIC)
3. InfiniBand Host Connectors
4. SAS Expansion Connector

Host Channels on the CE5400-24 Controller-Drive Tray or the CE5400-12 Controller-Drive Tray – Rear View

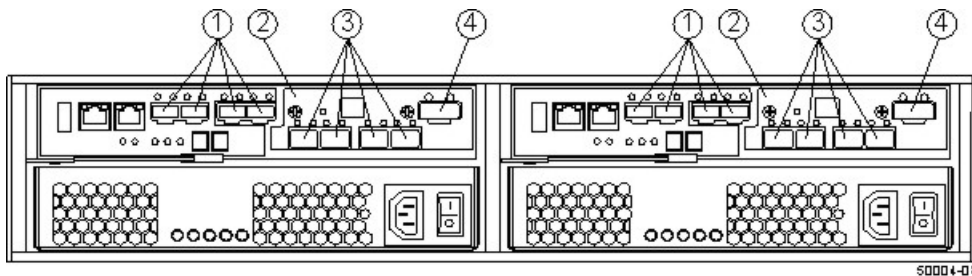

1. Standard Host Connectors
2. Host Interface Card (HIC)
3. FC Connectors
4. SAS Expansion Connector



WARNING (W03) Risk of exposure to laser radiation – Do not disassemble or remove any part of a Small Form-factor Pluggable (SFP) transceiver because you might be exposed to laser radiation.

Procedure – Connecting Host Cables on a CE5400 Controller-Drive Tray



NOTE Make sure that you have installed the HBAs. Refer to the documentation for the HBAs for information about how to install the HBA and how to use the supplied configuration utilities.

The type of HICs (FC or Infiniband) must match the type of the host bus adapters (HBAs) or host channel adapters (HCAs) to which you connect them.

See the examples in the following section for example cabling patterns.

1. Make sure that the appropriate type of SFP transceiver is inserted into the host channel.

2. If a black, plastic plug is in the SFP transceiver, remove it.
3. Perform one of these actions:
 - **You are using InfiniBand connections** – Starting with the first host channel of each controller, plug one end of the cable into the host channel.
 - **You are using Fibre Channel connections** – Starting with the first host channel of each controller, plug one end of the cable into the SFP transceiver in the host channel.



NOTE If Remote Volume Mirroring connections are required, do not connect a host to the highest numbered host channel.

Direct-Attach Topology – One Host and a Controller-Drive Tray

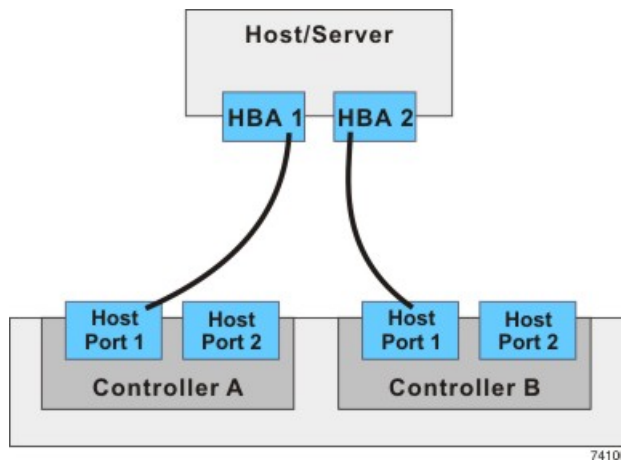

Direct-Attach Topology – Two Hosts and One Controller-Drive Tray

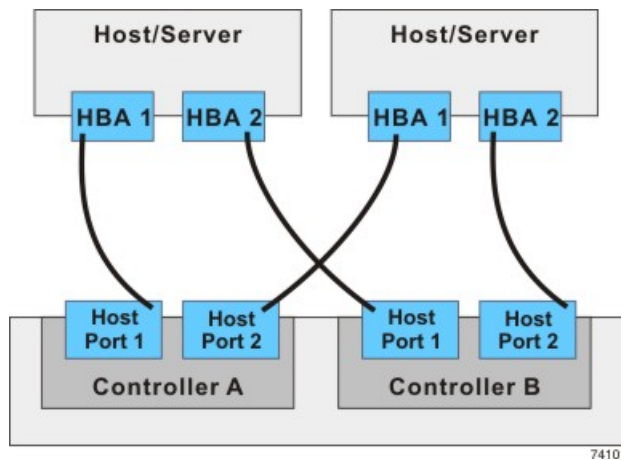

In the following figure, each outlined group of ports represents a zone.

Switch Topology – Two Hosts and One Controller-Drive Tray with a Zoned Switch

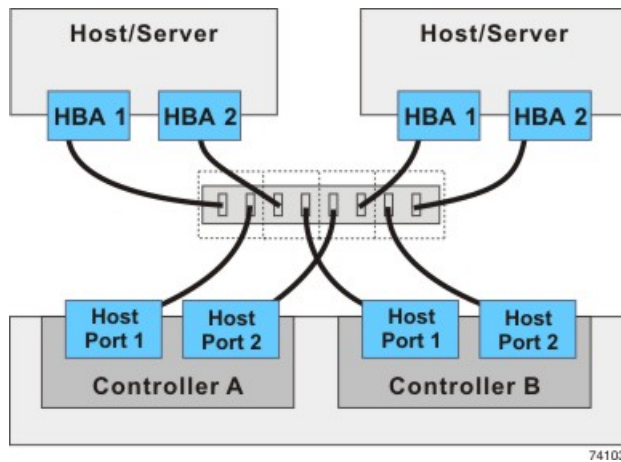

Mixed Topology – Three Hosts and One Controller-Drive Tray

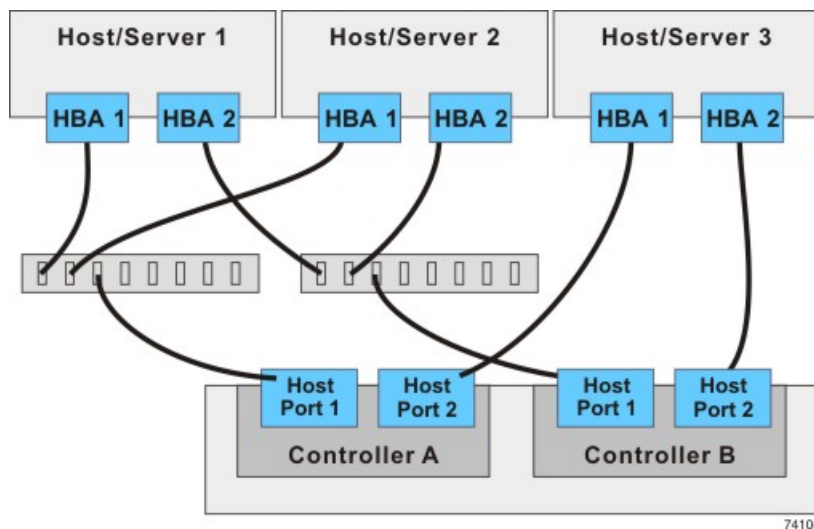

4. Plug the other end of the cable either into an HBA in the host (direct topology) or into a switch (fabric topology).
5. Affix a label to each end of the cable with this information. A label is very important if you need to disconnect cables to service a controller. Include this information on the labels:
 - The host name and the HBA port or HCA port (for direct topology)
 - The switch name and the port (for fabric topology)
 - The controller ID (for example, controller A)
 - The host channel ID (for example, host channel 1)

Example label abbreviation – Assume that a cable is connected between port 1 in HBA 1 of a host named Engineering and host channel 1 of controller A. A label abbreviation could be as follows.

Heng-HBA1/P1, CtA-Hch1

6. Repeat step 3 through step 6 for each controller and host channel that you intend to use.

Step 6 – Installing the Drive Trays for the CE5400 Controller-Drive Tray Configurations

Things to Know – General Installation of Drive Trays

 **NOTE** If you are installing the drive tray in a cabinet with other trays, make sure that the combined power requirements of the drive tray and the other trays do not exceed the power capacity of your cabinet. For more information, refer to the SANtricity ES Storage Manager Installation DVD.

- Special site preparation is not required for any of these drive trays beyond what is normally found in a computer lab environment.
- The power supplies meet standard voltage requirements for both domestic and worldwide operation.
- Take these precautions:
 - Install the drive trays in locations within the cabinet that let you evenly distribute the drive trays around the controller-drive tray.
 - Keep as much weight as possible in the bottom half of the cabinet.

For Additional Information on Drive Tray Installation

Refer to the *Storage System Site Preparation Guide* on the SANtricity ES Storage Manager Installation DVD for important considerations about cabinet installation.

Procedure – Installing the DE1600 Drive Trays and the DE5600 Drive Trays

 **WARNING** (W08) **Risk of bodily injury** –



>18 kg (39.7 lbs)

Two persons are required to safely lift the component.

 **WARNING** (W05) **Risk of bodily injury** – If the bottom half of the cabinet is empty, do not install components in the top half of the cabinet. If the top half of the cabinet is too heavy for the bottom half, the cabinet might fall and cause bodily injury. Always install a component in the lowest available position in the cabinet.

You can install the drive tray into an industry standard cabinet.

This procedure describes how to install the mounting rails into an industry standard cabinet.

 **ATTENTION Possible hardware damage** – To prevent electrostatic discharge damage to the tray, use proper antistatic protection when handling tray components.

1. Make sure that the cabinet is in the final location. Make sure that you meet the clearance requirements shown in the following two figures.

DE1600 Drive Tray Airflow and Clearance Requirements

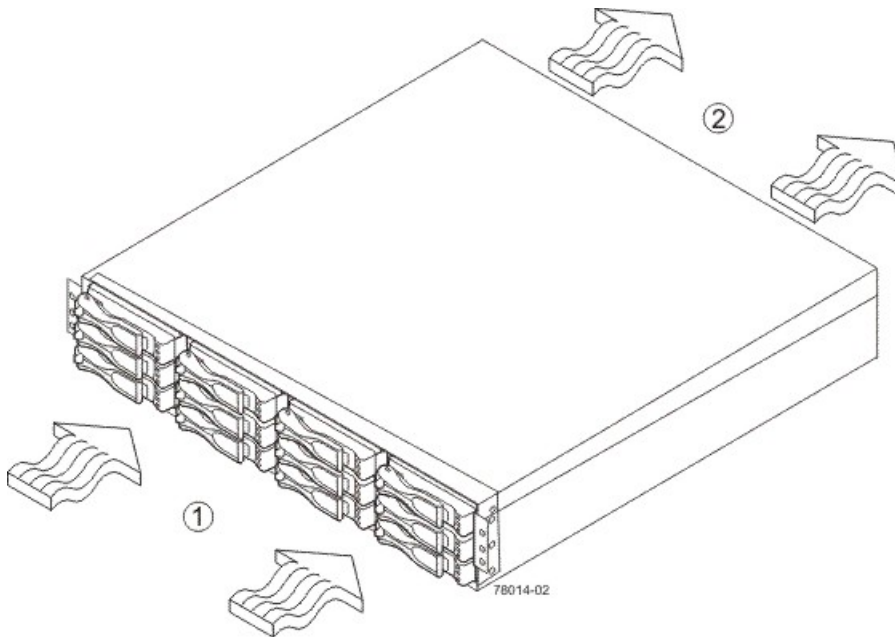

1. 76 cm (30 in.) clearance in front of the cabinet
2. 61 cm (24 in.) clearance behind the cabinet

DE5600 Drive Tray Airflow and Clearance Requirements

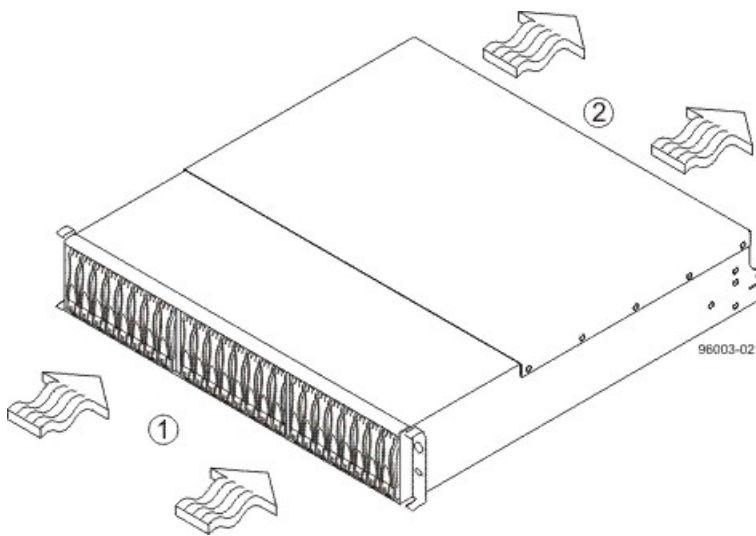

1. 76 cm (30 in.) clearance in front of the cabinet
2. 61 cm (24 in.) clearance behind the cabinet



NOTE Fans pull air through the tray from front to back across the drives.

2. Lower the feet on the cabinet to keep the cabinet from moving.
3. Remove the drive tray and all contents from the shipping carton.
4. Position the mounting rails in the cabinet.

Positioning the Mounting Rails in the Cabinet

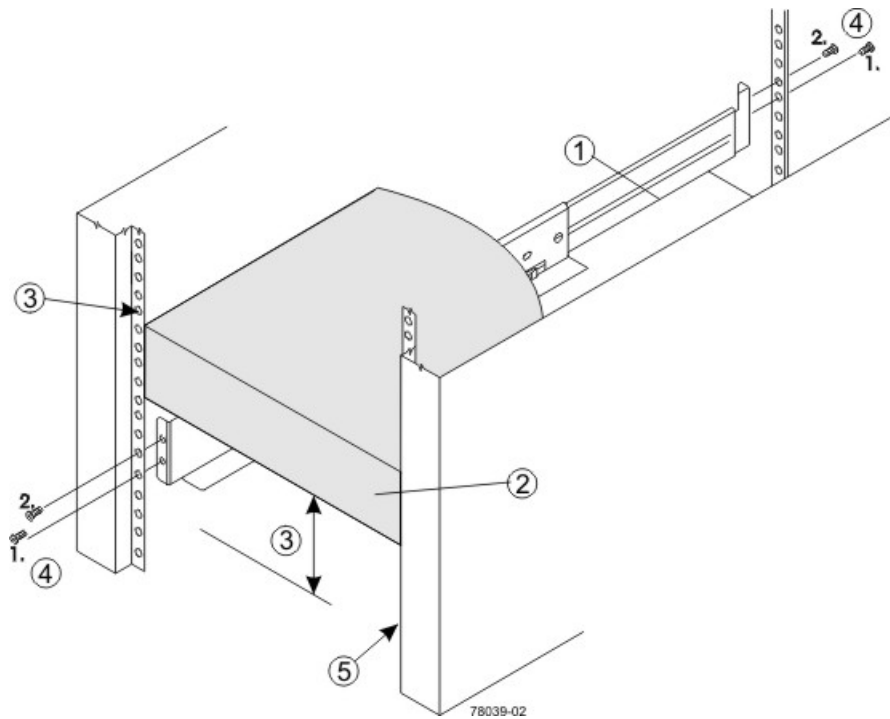

1. Mounting Rail
2. Existing Tray
3. Clearance Above and Below the Existing Tray
4. Screws for Securing the Mounting Rail to the Cabinet (Front and Rear)
5. Industry Standard Cabinet

- If you are installing the mounting rails above an existing tray, position the mounting rails directly above the tray.
 - If you are installing the mounting rails below an existing tray, allow 8.8-cm (3.5-in.) vertical clearance for the drive tray.
5. Attach the mounting rails to the cabinet by performing these substeps:
 - a. Make sure that the adjustment screws on the mounting rail are loose so that the mounting rail can extend or contract as needed.

Attaching the Mounting Rails to the Cabinet

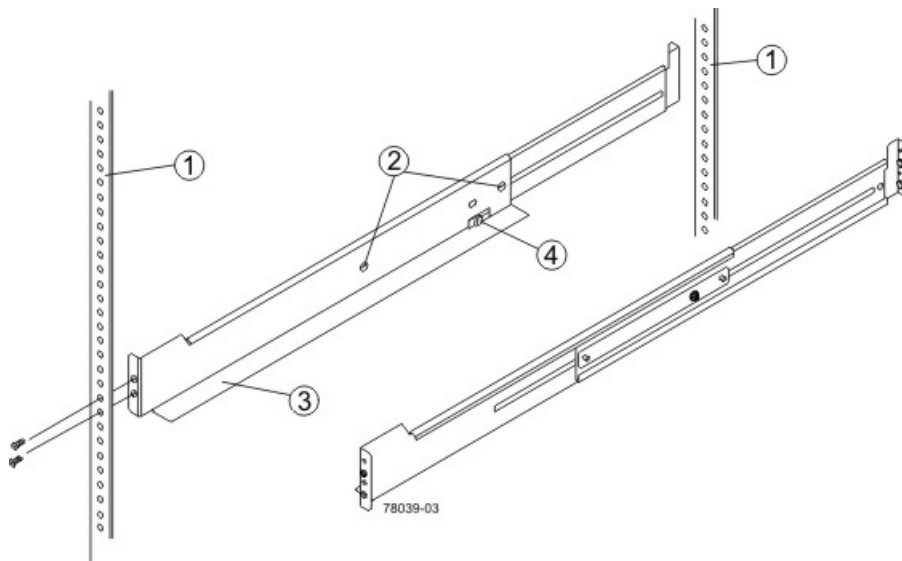

1. Cabinet Mounting Holes
 2. Adjustment Screws for Locking the Mounting Rail Length
 3. Mounting Rails
 4. Clip for Securing the Rear of the Drive Tray
- b. Place the mounting rail inside the cabinet, and extend the mounting rail until the flanges on the mounting rail touch the inside of the cabinet.
- c. Make sure that the alignment spacers on the front flange of the mounting rail fit into the mounting holes in the cabinet.

The front flange of each mounting rail has two alignment spacers. The alignment spacers are designed to fit into the mounting holes in the cabinet. The alignment spacers help position and hold the mounting rail.

Alignment Spacers on the Mounting Rail

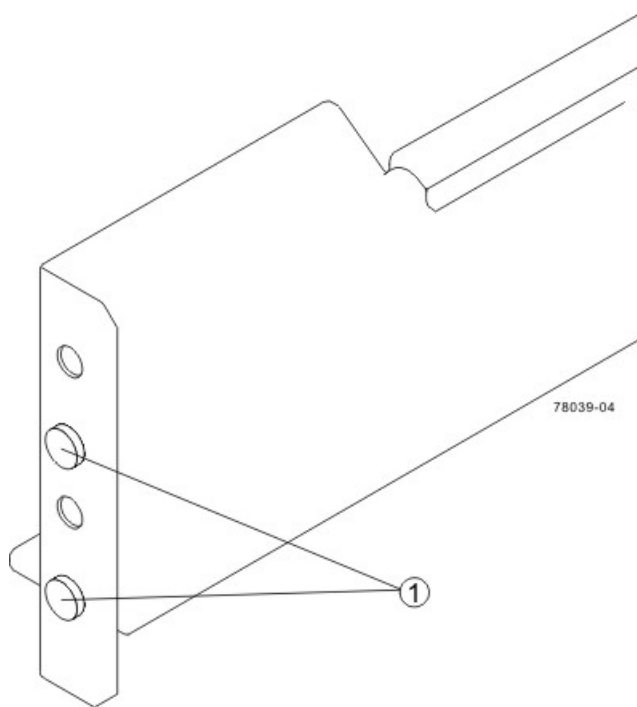

1. Alignment Spacers
 - d. Insert one M5 screw through the front of the cabinet and into the top captured nut in the mounting rail. Tighten the screw.
 - e. Insert two M5 screws through the rear of the cabinet and into the captured nuts in the rear flange in the mounting rail. Tighten the screws.
 - f. Tighten the adjustment screws on the mounting rail.
 - g. Repeat substep a through substep f to install the second mounting rail.
6. With the help of one other person, slide the rear of the drive tray onto the mounting rails. The rear edge of the drive tray must fit into the clip on the mounting rail. The drive tray is correctly aligned when these conditions are met:
 - The mounting holes on the front flanges of the drive tray align with the mounting holes on the front of the mounting rails.
 - The rear edge of the drive tray sheet metal fits into the clip on the mounting rail.
 - The holes in the drive tray sheet metal for the rear hold-down screws align with the captured nuts in the side of the mounting rails.

Sliding the Drive Tray into the Clip on the Mounting Rail

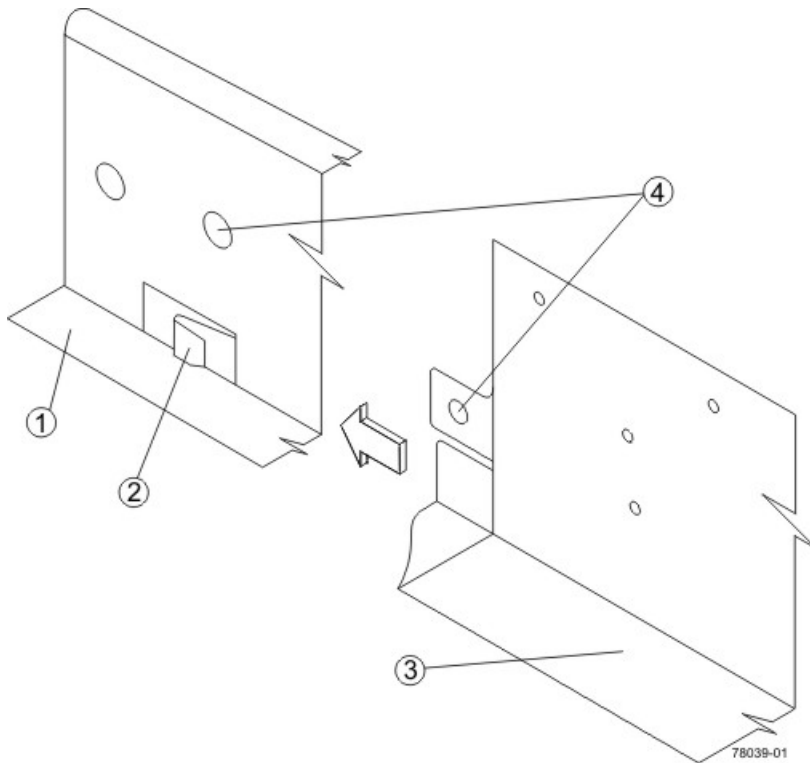

1. Mounting Rail
 2. Clip
 3. Partial View of the Drive Tray Rear Sheet Metal
 4. Align the hole in the drive tray sheet metal with the captured nut in the mounting rail.
7. Secure the front of the drive tray to the cabinet. Use the two screws to attach the flange on each side of the front of the drive tray to the mounting rails.
- a. Insert one M5 screw through the bottom hole of a flange on the drive tray so that the screw goes through the cabinet rail and engages the bottom captured nut in the mounting rail. Tighten the screw.
 - b. Repeat substep a for the second flange.

Attaching the Front of the DE1600 Drive Tray

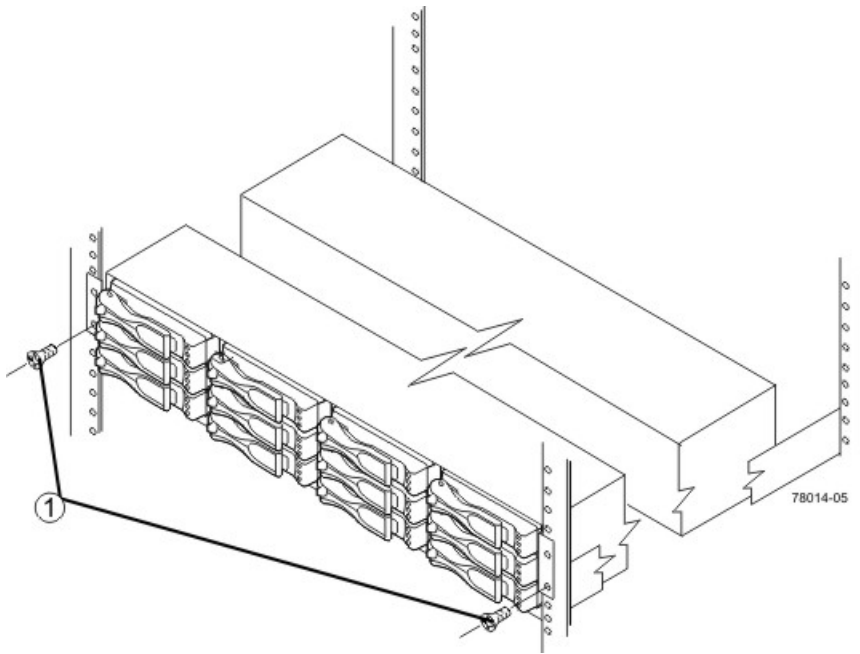

1. Screws for Securing the Front of the Drive Tray

Attaching the Front of the DE1600 Drive Tray

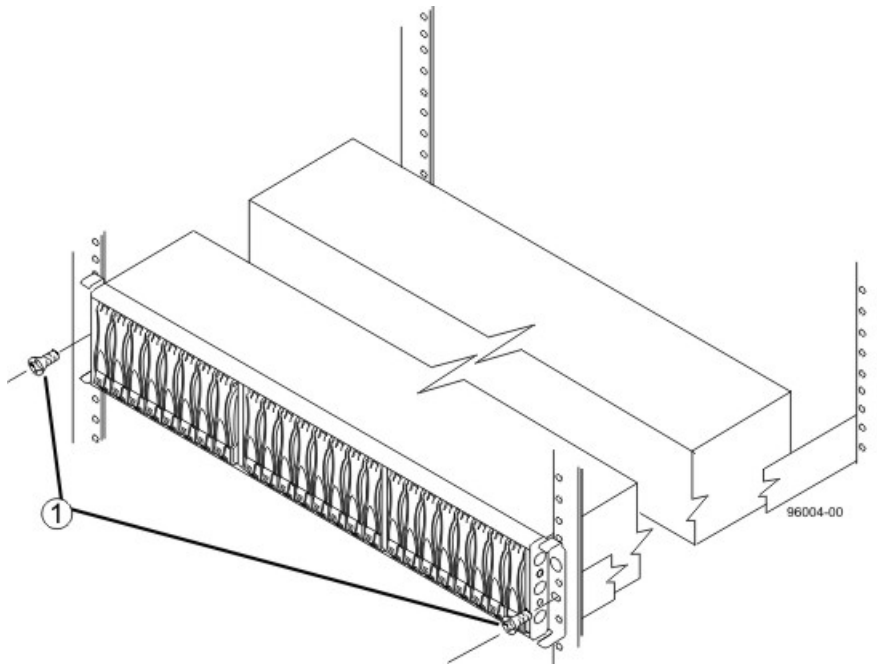

1. Screws for Securing the Front of the Drive Tray
8. Secure the side of the drive tray to the mounting rails by performing these substeps:
 - a. Insert one M4 screw through the side sheet metal of the DE1600 drive tray into the captured nut on the side of the mounting rail. Tighten the screw.
 - b. Repeat substep a for the other side.
9. Attach the plastic end caps onto the front of the drive tray.
 - a. Put the top of the end cap on the hinge tab that is part of the drive tray mounting flange.
 - b. Gently press on the bottom of the end cap until it snaps into place over the retainer on the bottom of the drive tray mounting flange.

Attaching the End Caps to the DE1600 Drive Tray

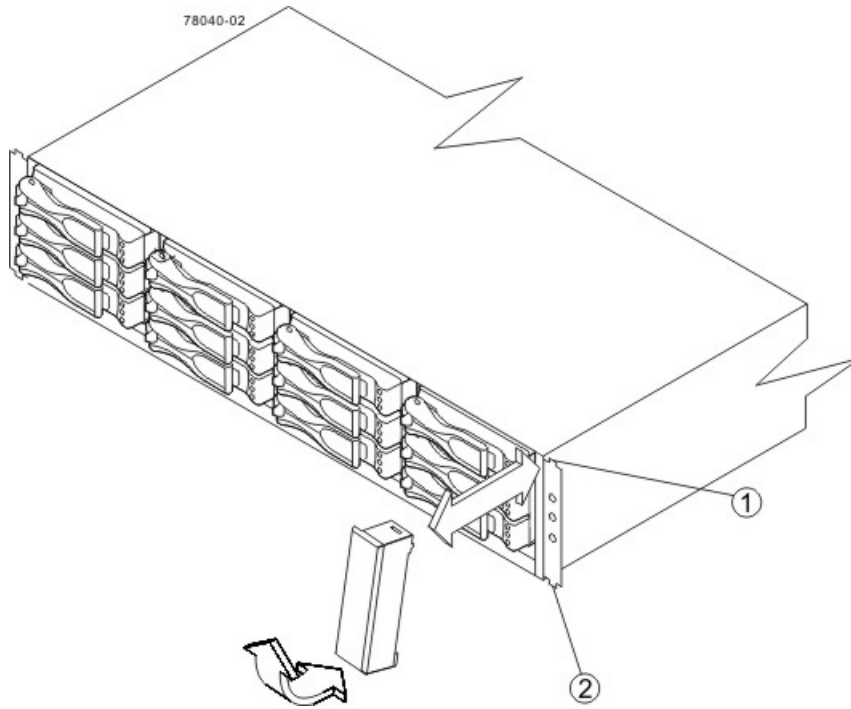

1. Hinge Tab
2. Retainer

Attaching the End Caps to the DE5600 Drive Tray

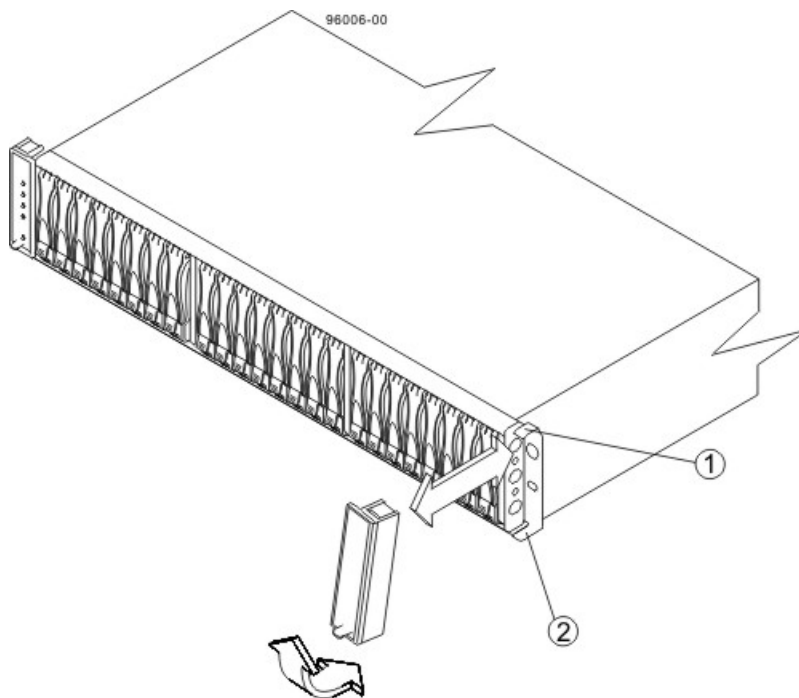

1. Hinge Tab
2. Retainer

Procedure – Installing the DE6600 Drive Trays

You can install the high-density, 6-Gb SAS SBB 2.0-compliant DE6600 drive tray into an Industry-standard cabinet, provided it has a depth of 100 cm (40 in.).

A minimum depth of 76 cm (30 in.) between the front EIA support rails and the rear EIA support rails is required.



NOTE If you are mounting the DE6600 drive tray in a cabinet with square holes, use the eight shoulder washers in the rail kit to align the screws in the holes (see [step 4](#) through [step 7](#)).

1. Make sure that the cabinet is in the final location. Make sure that you meet the clearance requirements shown in the following figure.

DE6600 Drive Tray Airflow Direction and Clearance Requirements

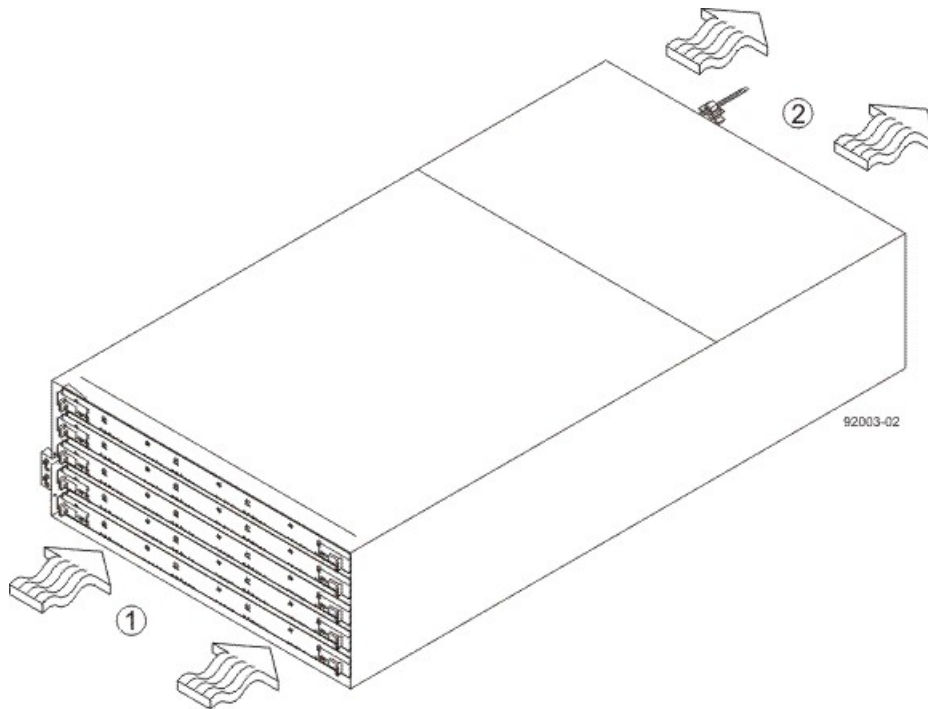

1. 81 cm (32 in.) clearance in front of the cabinet
2. 61 cm (24 in.) clearance behind the cabinet



NOTE Fans pull air through the drive tray from front to back across the drives.

2. Lower the feet on the cabinet to keep the cabinet from moving.



WARNING (W09) Risk of bodily injury –



>35 kg (70.5 lbs)

Three persons are required to safely lift the component.



WARNING (W15) Risk of bodily injury – An empty tray weighs approximately 56.7 kg (125 lb). Three persons are required to safely move an empty tray. If the tray is populated with components, a mechanized lift is required to safely move the tray.

3. With the help of at least two other persons, remove the drive tray and all of the contents from the shipping carton, using the four drive tray handles (two to a side) as shown in the following figure. Set the drive tray aside.

DE6600 Drive Tray with Drive Tray Handles (Two on Each Side)

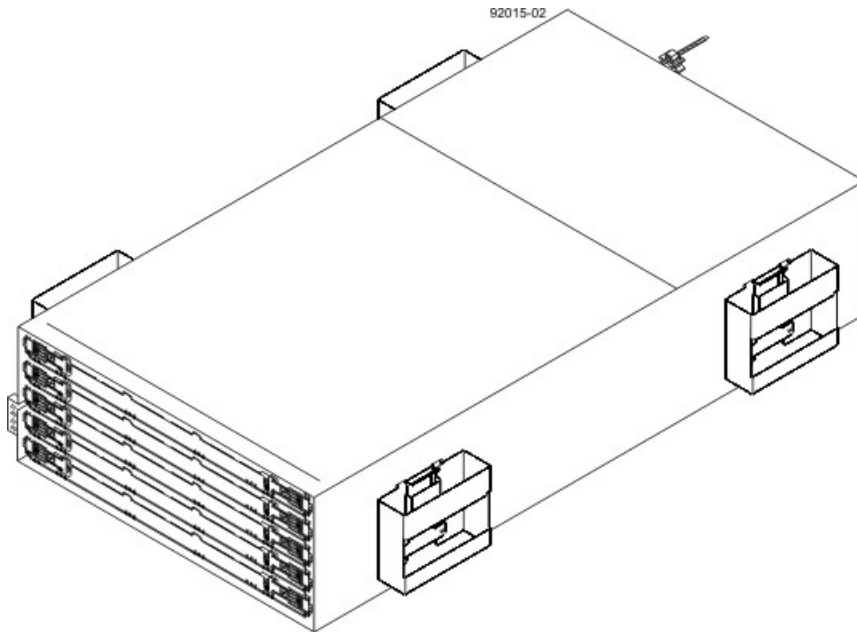

4. Position the mounting rails in the cabinet.

Positioning the Mounting Rails in the Cabinet

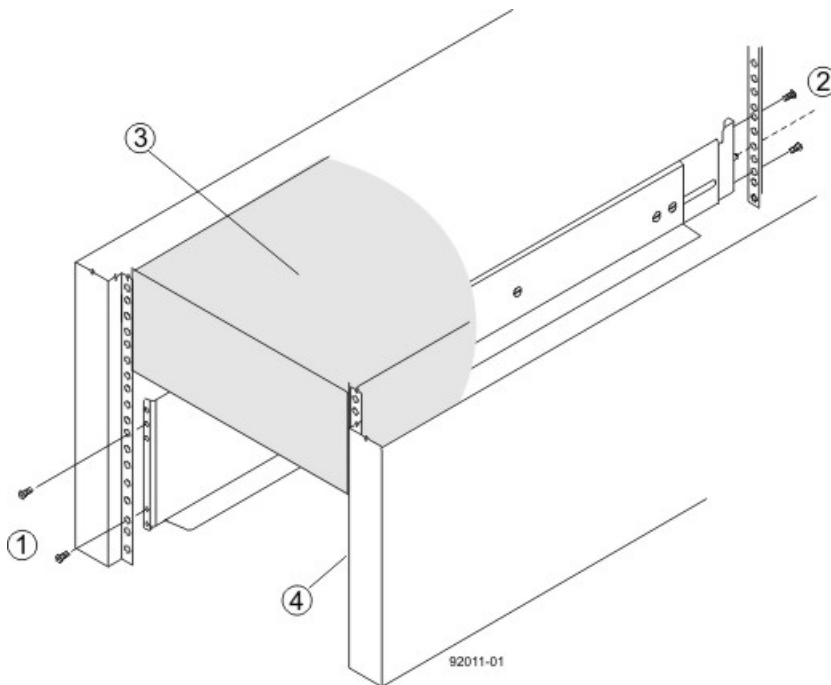

1. Screws for Securing the Mounting Rail to the Cabinet (Front)
 2. Screws for Securing the Mounting Rail to the Cabinet (Rear)
 3. Existing Tray
 4. Industry-Standard Cabinet
- If you are installing the mounting rails above an existing tray, position the mounting rails directly above the tray.

- If you are installing the mounting rails below an existing tray, allow 17.8-cm (7-in.) vertical clearance for a DE6600 drive tray.
5. To attach the mounting rails to the cabinet, do one of the following:
 - If you are using the long, fixed-size mounting rails, go to [step 6](#).
 - If you are using the shorter adjustable mounting rails, go to [step 7](#).
 6. To attach the long mounting rails to the cabinet, perform these substeps:
 - a. Make sure that the adjustment screws on the mounting rail are loose so that the mounting rail can extend or contract as needed.

Attaching the Long Mounting Rails to the Cabinet

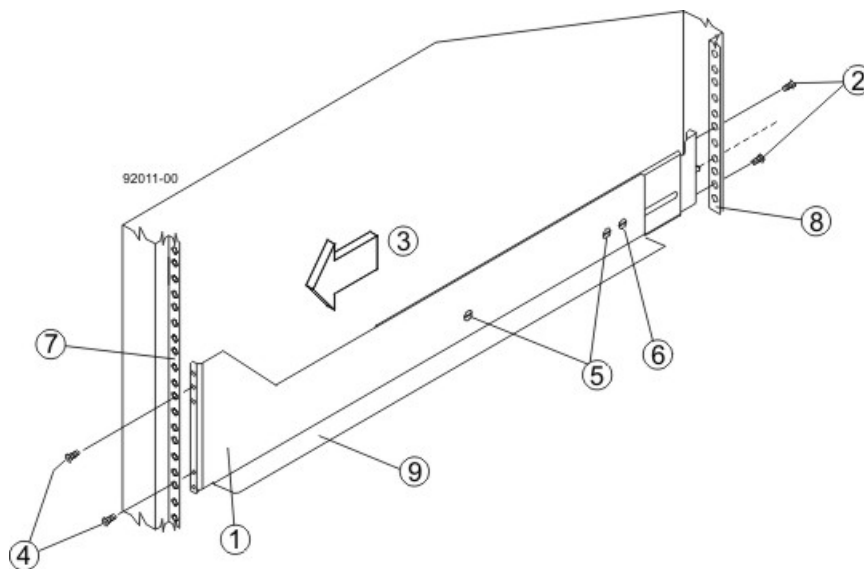

1. Front of the Mounting Rail
 2. Two M4 Screws for the Rear EIA Support Rail
 3. Front of the Cabinet
 4. Two M5 Screws for the Front EIA Support Rail
 5. Adjustment Screws
 6. Rear Hold-Down Screw
 7. Cabinet Mounting Holes on the Front EIA Support Rail
 8. Cabinet Mounting Holes on the Rear EIA Support Rail
 9. Mounting Rail Lip
- b. Remove the rear hold-down screw. It protrudes from the inside of the rail and prevents you from sliding the drive tray onto the rails.
 - c. Place the mounting rail inside the cabinet, and extend the mounting rail until the flanges on the mounting rail touch the inside of the cabinet.
 - d. Insert one M5 screw through the front of the cabinet, and screw it into the top captured nut in the mounting rail.
 - e. Insert two M5 screws through the rear of the cabinet, and screw them into the captured nuts in the rear flange in the mounting rail.
 - f. Tighten the adjustment screws on the mounting rail.
 - g. Repeat substep a through substep f to install the second mounting rail.
 - h. Insert one M5 screw through the front of the mounting rail. You use this screw to attach the drive tray to the cabinet.

7. To attach the short, adjustable size mounting rails to the cabinet, perform these sets of substeps:

Short Adjustable Mounting Rail -- Left Side

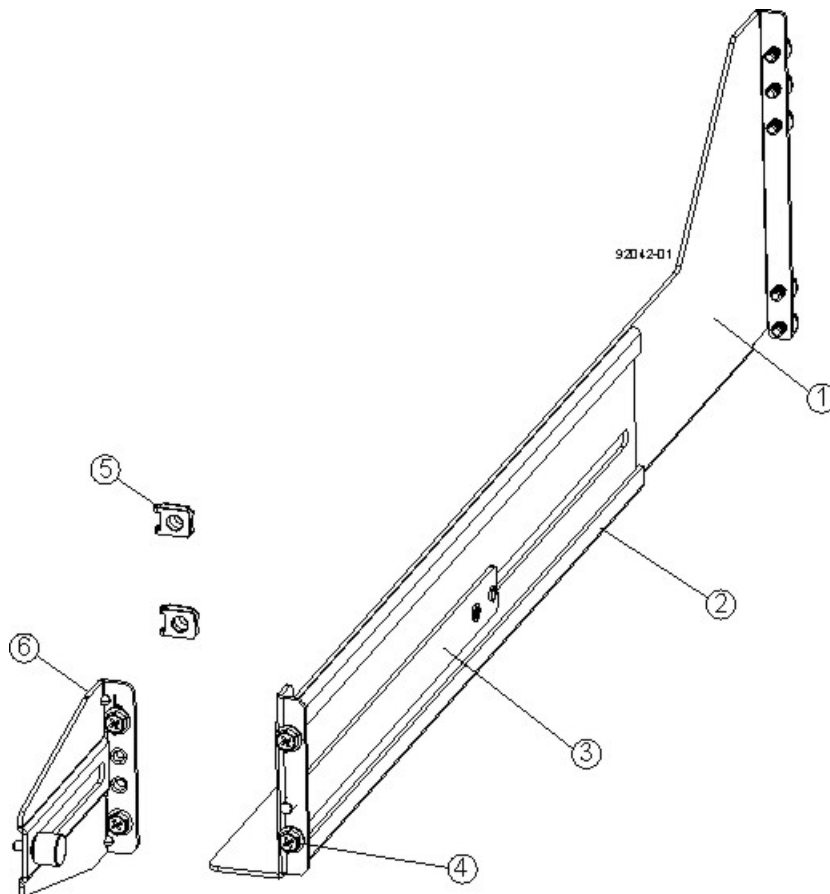

1. Front of the Mounting Rail
2. Rear of the Mounting Rail
3. Rail Fix Bar
4. Two M5 Screws for the Front EIA Support Rail
5. Two Clips for the Front EIA Support Rail
6. Rear Bracket

- a. Make sure that the adjustment screws on the mounting rail are loose so that the mounting rail can extend or contract as needed (see the figure [Short Adjustable Mounting Rail -- Left Side](#)).
- b. Place the mounting rail inside the cabinet, and extend the mounting rail until the flanges on the mounting rail touch the inside of the cabinet (see the figure [Short Adjustable Mounting Rail Attached to the Cabinet](#)).
- c. Insert one M5 screw through the front of the cabinet, and screw it into the top captured nut in the mounting rail.
- d. Insert two M5 screws through the rear of the cabinet, and screw them into the captured nuts in the rear flange in the mounting rail.
- e. Tighten the adjustment screws on the mounting rail.
- f. Repeat substep a through substep e to install the second mounting rail.
- g. Insert one M5 screw through the front of the mounting rail. This screw will attach the drive tray to the cabinet.

Short Adjustable Mounting Rail Attached to the Cabinet

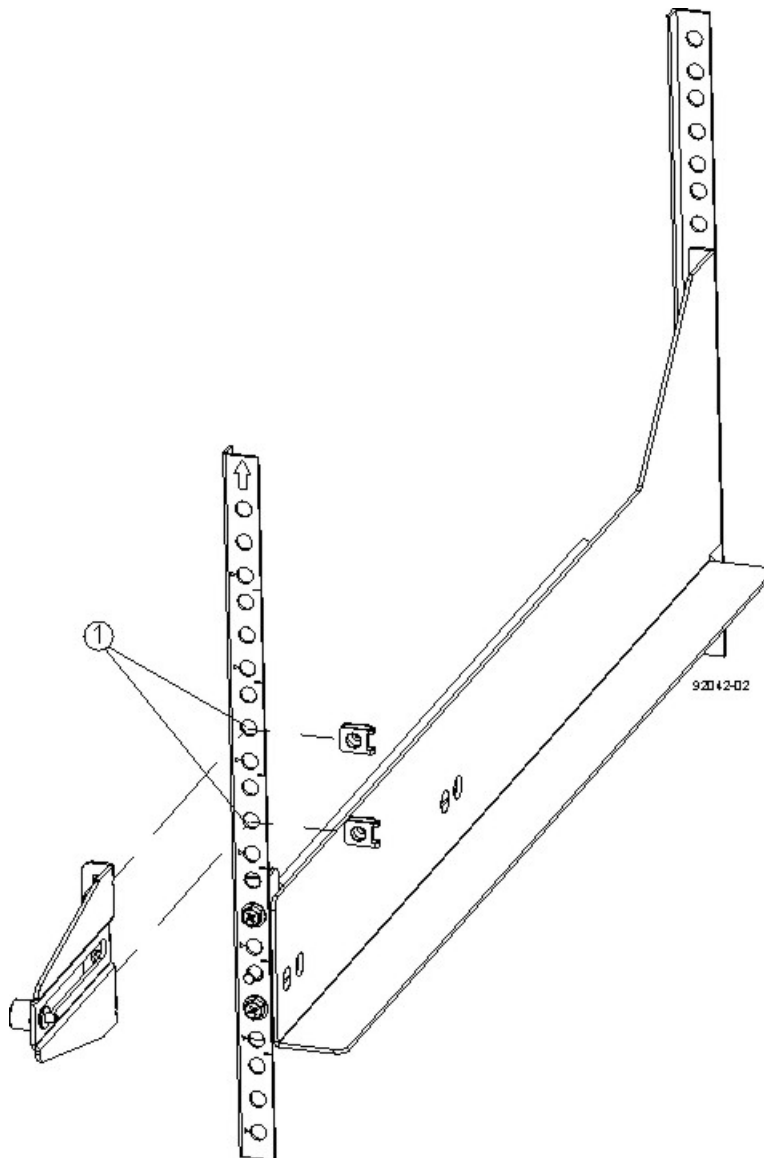

1. Cabinet Mounting Holes on the Front EIA Support Rail

8. Remove the bezel from the front of the drive tray.



WARNING (W09) Risk of bodily injury –



>35 kg (70.5 lbs)

Three persons are required to safely lift the component.

9. With the help of at least two other persons, slide the rear of the drive tray onto the mounting rails. The drive tray is correctly aligned when the mounting holes on the front flanges of the drive tray align with the mounting holes on the front of the mounting rails.

 **WARNING (W15) Risk of bodily injury** – An empty tray weighs approximately 56.7 kg (125 lb). Three persons are required to safely move an empty tray. If the tray is populated with components, a mechanized lift is required to safely move the tray.

10. After the controller-drive tray is correctly aligned, remove the enclosure lift handles as shown in the figure [Removing an Enclosure Lift Handle from the Drive Tray](#):
 - a. Use your thumb to unlatch and remove the rear enclosure lift handles (two to a side).
 - b. Use the front enclosure lift handles to slide the drive tray all the way into the cabinet.
 - c. After the drive tray is securely in the cabinet, use your thumb to unlatch and remove the front drive tray lift handles (two to a side).

Removing a Drive Tray Lift Handle from the DE6600 Drive Tray

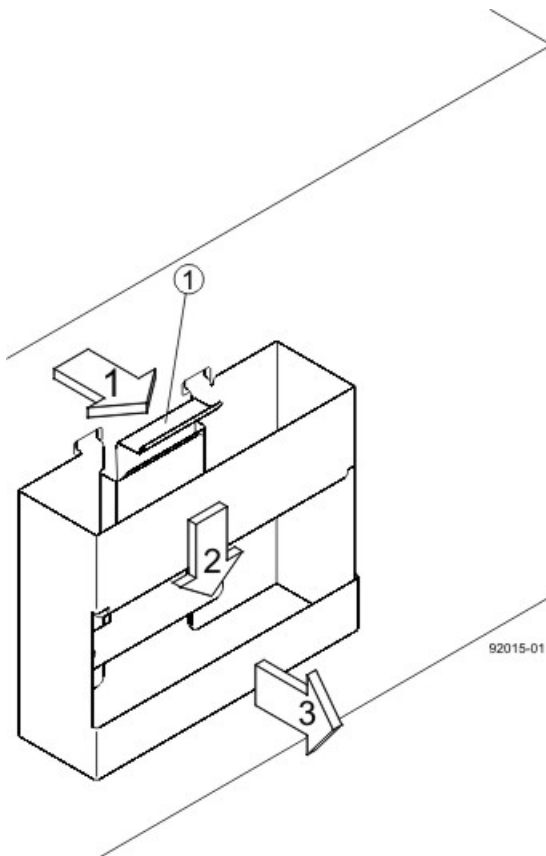

1. Pull the thumb latch away from the drive tray to detach the hook.
 2. Shift the handle down to release the other four hooks.
 3. Move the handle away from the drive tray.
11. Secure the front of the drive tray to the cabinet. Use the four screws to attach the flange on each side of the front of the drive tray to the mounting rails.
 - a. Insert two M5 screws through the bottom holes of a flange on the drive tray so that the screws go through the EIA support rail and engage the bottom captured nuts in the mounting rail. Tighten the screws.
 - b. Repeat substep a for the second flange.

Attaching the Front of the DE6600 Drive Tray

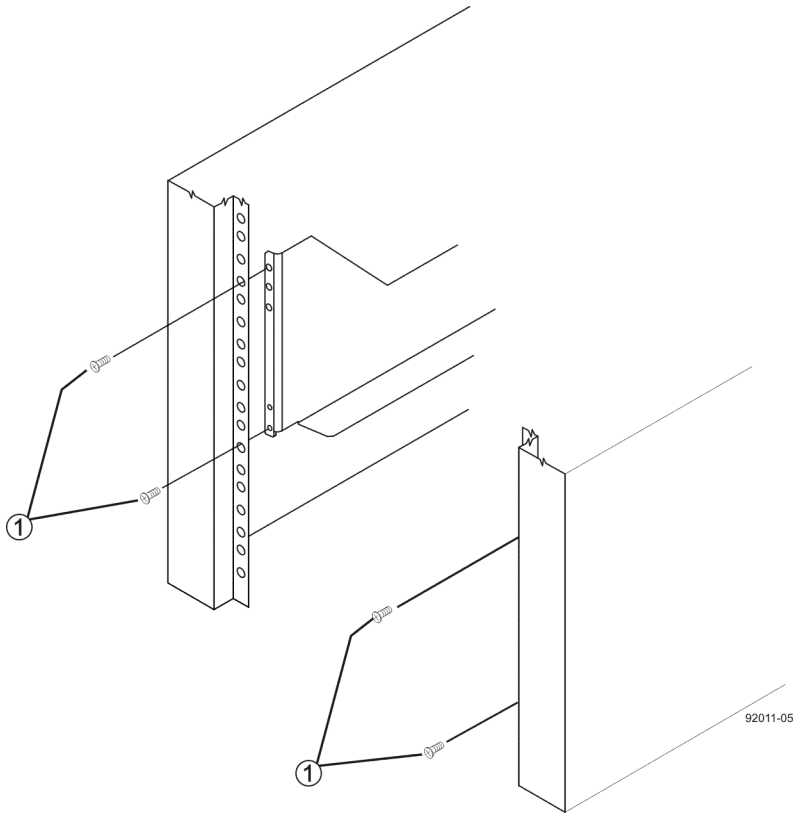

1. Four Screws for Securing the Front of the Drive Tray
12. Remove the fan canister from the drive tray by pressing on the tab holding the fan canister handle in place, and then pulling the fan canister toward you.

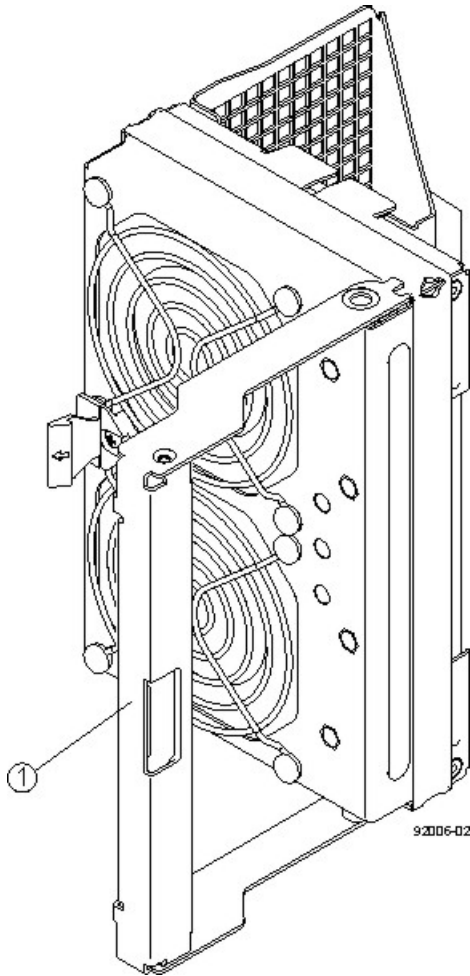

1. Fan Canister Handle

13. Use the fan canister handle to pull the fan canister out of the drive tray.

14. Secure the side of the drive tray to the mounting rails by performing these substeps:

Securing the DE6600 Drive Tray to the Rails

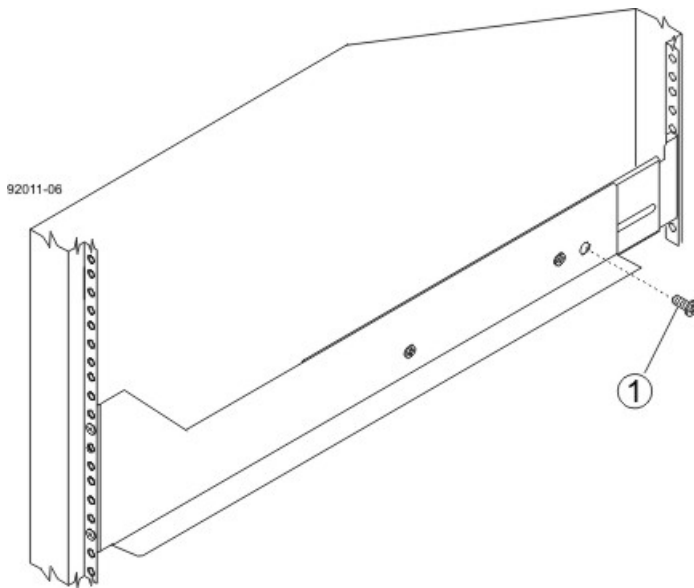

1. 10-32 Screw

- a. Insert a 10-32 screw through the side sheet metal of the drive tray into the captured nut on the side of the mounting rail. Tighten the screws.
- b. Repeat substep a for the other side.



NOTE After the drive tray is installed, there should be seven screws on each side (right and left) of the cabinet.



NOTE Make sure that each drive drawer in the drive tray is securely fastened to ensure proper air flow to the drives.

DE6600 Drive Tray Installed in the Cabinet

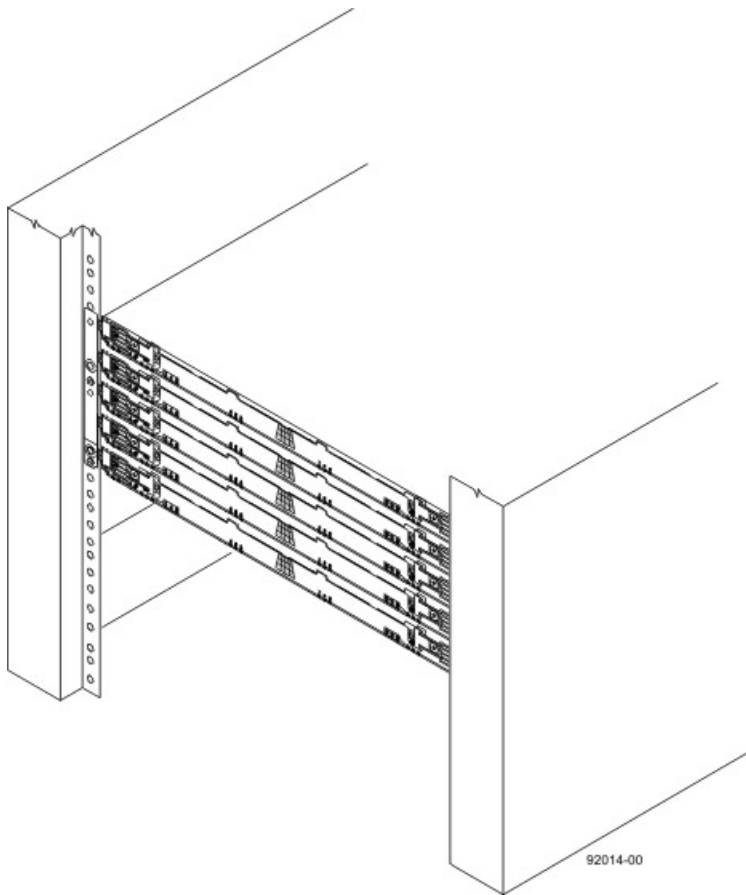

15. Slide the fan canister all the way back into the drive tray until the tab on the fan canister latches.
16. Attach the bezel onto the front of the drive tray.

Procedure – Installing the Drives in the DE6600 Drive Tray

The DE6600 drive tray is shipped with the drive drawers installed, but the drives are not installed. Follow the steps in this procedure to install the drives.

ATTENTION Risk of equipment malfunction – To avoid exceeding the functional and environmental limits, install only drives that have been provided or approved by the original manufacturer. Drives might be shipped but not installed. System integrators, resellers, system administrators, or users can install the drives.

NOTE The installation order within each drawer is from left to right in rows. Slots 1, 4, 7 and 10 must have a drive installed in these locations to make sure there is sufficient air flow to the drives. To verify these slots, consult the overlay on the front of each of the five drive drawers. Make sure the four drives in each row are adjacent to each other. The long edge of each drive should touch the drive next to it. To maintain a uniform airflow across all drive drawers, the drive tray must be configured with a minimum of 20 drives, with four drives in the front row of each of the five drive drawers.

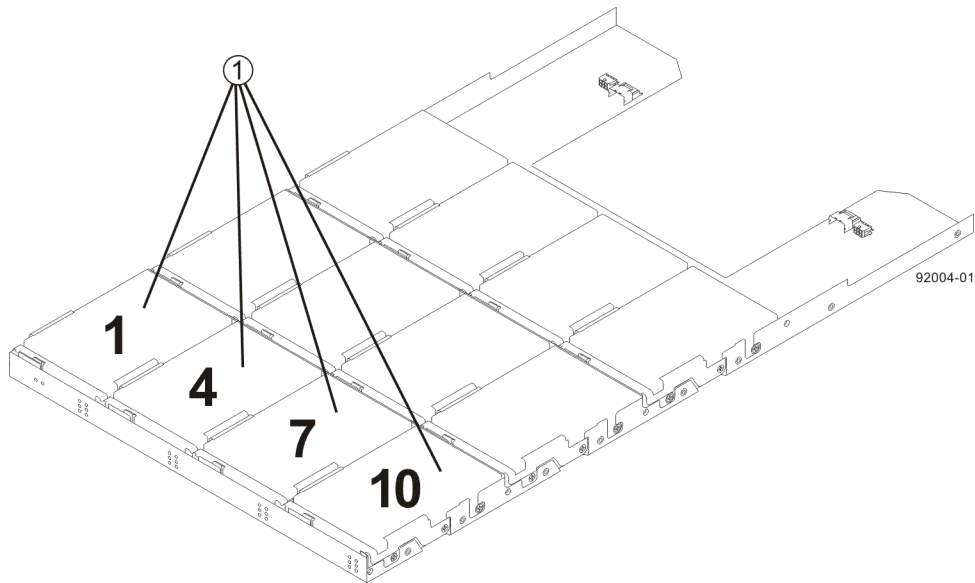

1. DE6600 Drive Tray with Slots 1, 4, 7, and 10



ATTENTION Risk of equipment malfunction – For the DE6600 drive tray, you can only replace one canister or drive at a time. Refer to the Replacing a Drive on the DE6600 Drive Tray Instructions on the SANtricity ES Storage Manager DVD, and make sure you have the replacement drive in hand before starting the task.

1. Beginning with the top drawer in the drive tray, release the levers on each side of the drive drawer by pulling both towards the center.

Drive Drawer Levers

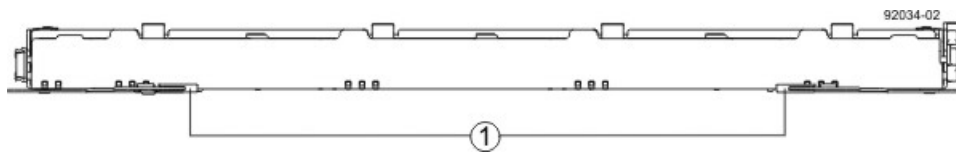

2. Pull on the extended levers to pull the drive drawer out to its full extension without removing it from the drive tray.
3. Starting with the first drive, raise the drive handle to the vertical position ([Raised Drive Handle](#)).

Raised Drive Handle

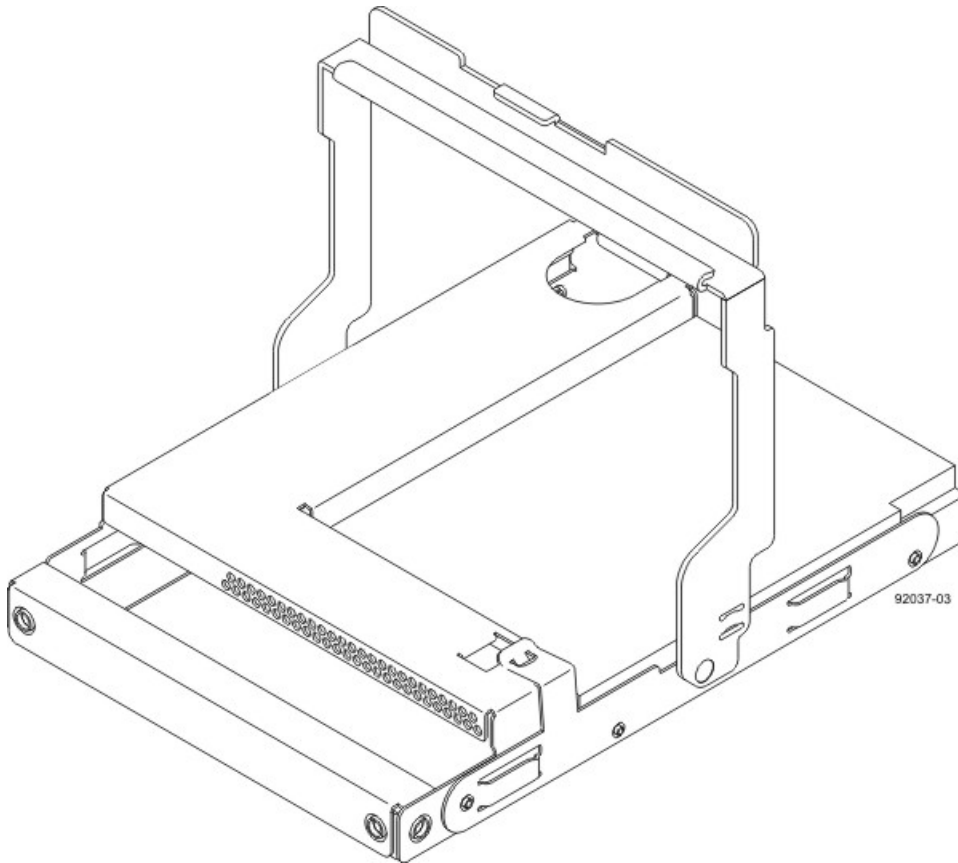

4. Align the two raised buttons on each side over the matching gap in the drive channel on the drive drawer.

Side View of Drive with the Drive Handle Closed

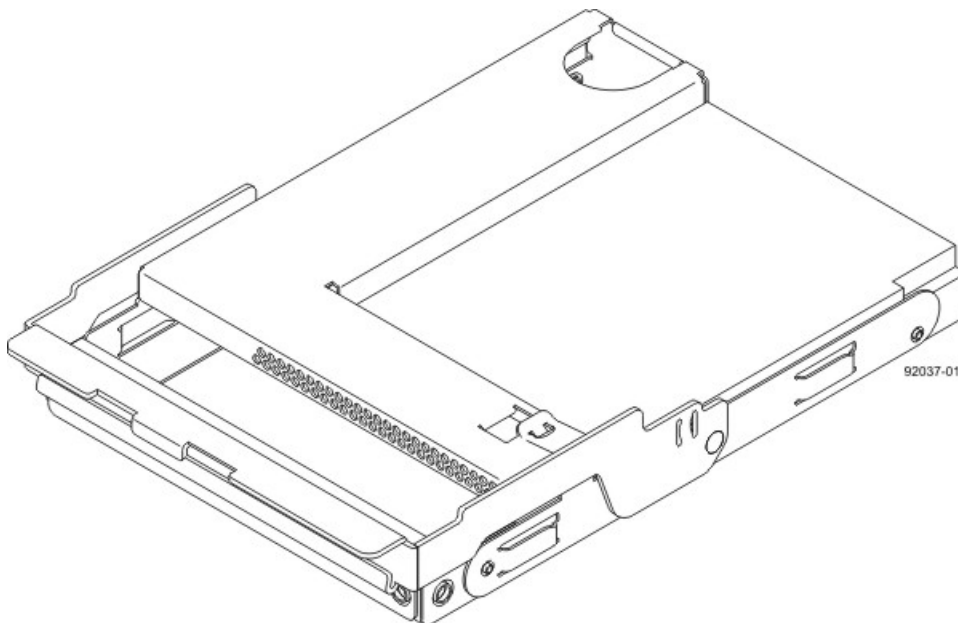

5. Lower the drive straight down, and then rotate the drive handle down until the drive snaps into place under the drive release lever.

Drive Release Lever Locked by the Drive Handle

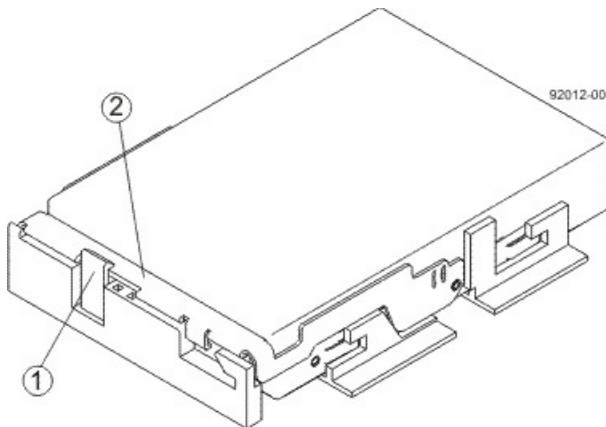

1. Drive Release Lever
2. Drive Handle

6. Install the other drives in rows from left to right until the drive drawer is fully populated.

Fully Populated Drive Drawer

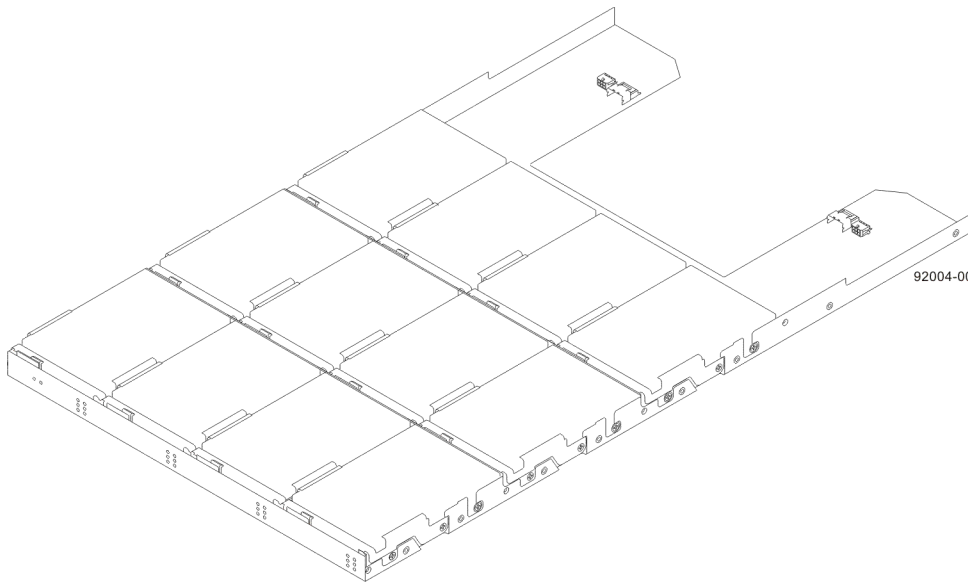

7. Push the drive drawer all the way back into the drive tray, closing the drive drawer levers on each side of the drive drawer.



ATTENTION Risk of equipment malfunction – Make sure you push both levers to each side so the drive drawer is completely closed. The drive drawer must be completely closed to prevent excess airflow, which has the potential to damage the drives.

8. Continue onto the next drive drawer, repeating step 1 through step 7 for each drive drawer in the configuration.

Procedure – Installing Drives in the DE1600 Drive Trays and the DE5600 Drive Trays

In some situations, the drive tray might be delivered without the drives installed. Follow the steps in this procedure to install the drives. If your drive tray already has drives installed, you can skip this step and go to either [Things to Know – AC Power Cords](#) or [Things to Know – DC Power Cords](#).

⚠ ATTENTION Risk of equipment malfunction – To avoid exceeding the functional and environmental limits, install only drives that have been provided or approved by the original manufacturer. Drives might be shipped but not installed. System integrators, resellers, system administrators, or users can install the drives.

📌 NOTE The installation order is from top to bottom and from left to right. The installation order is important because the drives might already contain configuration information that depends upon the correct sequence of the drives in the tray.

1. Beginning with the first drive slot in the upper-left side of the drive tray, place the drive on the slot guides, and slide the drive all the way into the slot.
2. Push the drive handle to the right (DE1600 drive tray) or down (DE5600 drive tray) to lock the drive securely in place.

Installing a Drive in the DE1600 Drive Tray

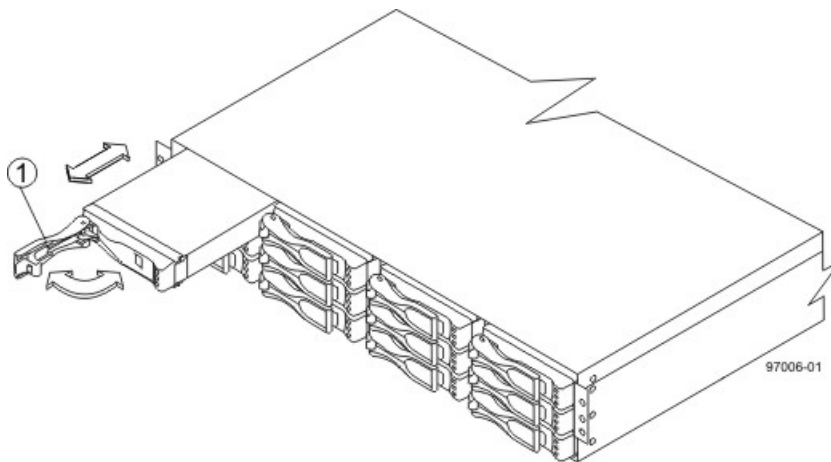

1. Drive Handle

Installing a Drive in the DE5600 Drive Tray

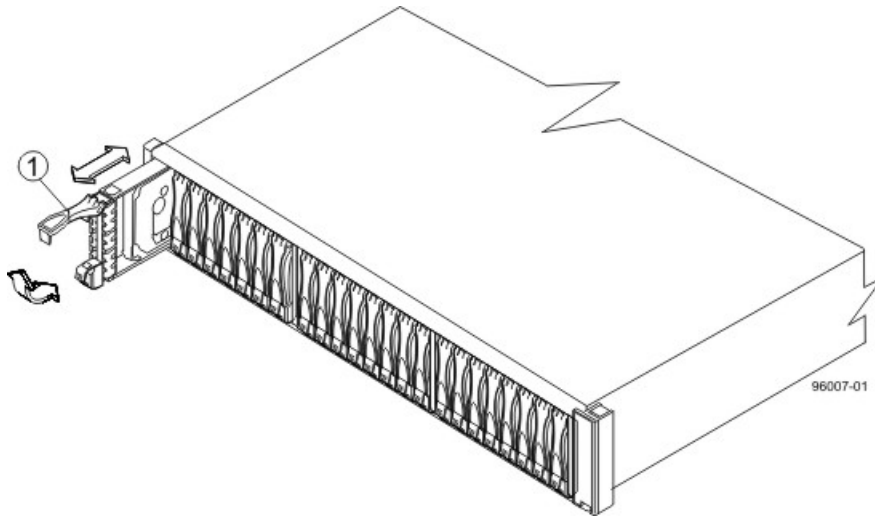

1. Drive Handle



NOTE In some applications, the drive handle might have the hinge on the right.

3. Install the second drive beneath the first drive (DE1600 drive tray) or to the right of the first drive (DE5600 drive tray).
4. Install the other drives from top to bottom and then from left to right (DE1600 drive tray) or to the right (DE5600 drive tray).

Step 7 – Connecting the CE5400 Controller-Drive Tray to the Drive Trays

Key Terms

drive channel

The path for the transfer of data between the controllers and the drives in the storage array.

Things to Know – CE5400 Controller-Drive Tray

- The CE5400 controller-drive trays supports the DE1600 drive tray, the DE5600 drive tray, and the DE6600 drive tray for expansion.
- For any one controller-drive tray, you must not exceed the limit of 15 connected drive trays or the limit for the total number of drives in the storage array. The drive limit for the High Performance Computing (HPC) configuration is 240 drives. For non-HPC configurations the limit is 384 drives. The drive limit includes drives installed in the controller-drive tray.
- Each controller has one SAS expansion connector to connect to the drive trays.

Drive Channel Ports on the CE5400-60 Controller-Drive Tray

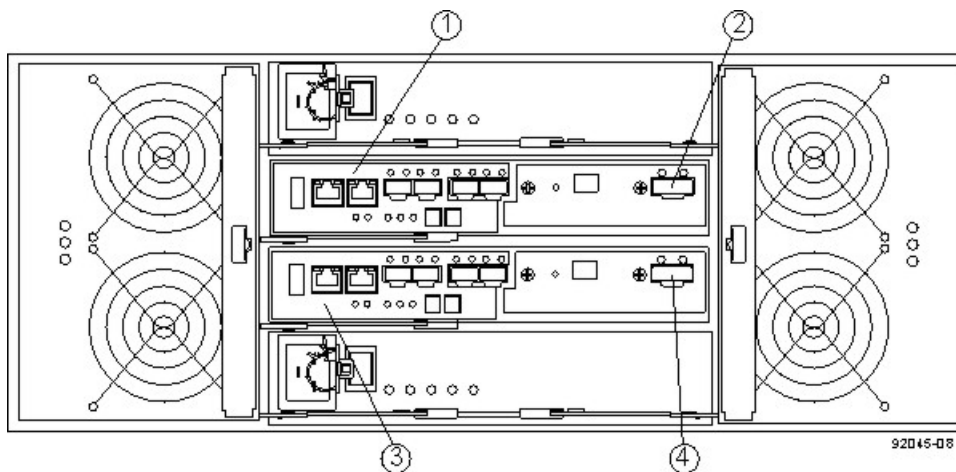

1. Controller Canister A
2. Drive Channel Port (SAS Drive Expansion Connector)
3. Controller Canister B
4. Drive Channel Port (SAS Drive Expansion Connector)

Drive Channel Ports on the CE5400-24 Controller-Drive Tray or the CE5400-12 Controller-Drive Tray

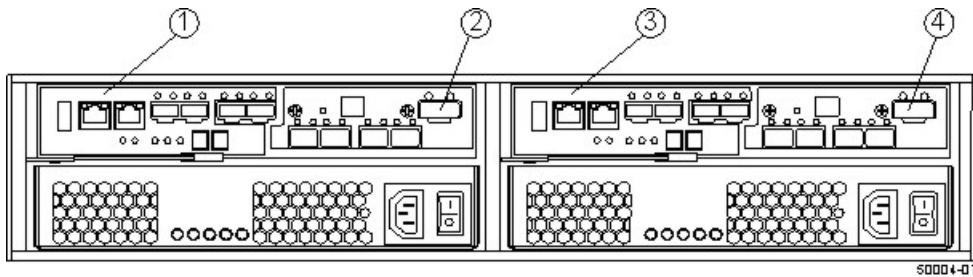

1. Controller Canister A
2. Drive Channel Port (SAS Drive Expansion Connector)
3. Controller Canister B
4. Drive Channel Port (SAS Drive Expansion Connector)



NOTE To maintain data access in the event of the failure of a controller, an ESM, or a drive channel, you must connect a drive tray or a string of drive trays to both drive channels on a redundant path pair.

Things to Know – Drive Trays with the CE5400 Controller-Drive Tray

- Each DE1600 drive tray can contain a maximum of twelve 8.89-cm (3.5-in.) drives.
- Each DE5600 drive tray can contain a maximum of twenty-four 6.35-cm (2.5-in.) drives.
- Each DE6600 drive tray can contain a maximum of sixty 8.89-cm (3.5-in.) drives.
- Each ESMs in the DE1600 drive tray, the DE5600 drive tray, or the DE6600 drive tray contains a pair of SAS In connectors and one SAS Expansion (Out) connector.

DE1600 Drive Tray and DE5600 Drive Tray – Rear View

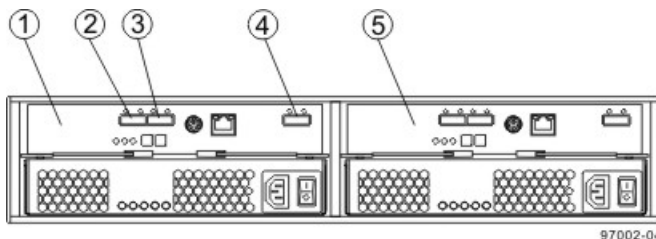

1. ESM A
2. SAS IN Connector
3. SAS IN Connector
4. SAS Expansion (Out) Connector
5. ESM B

DE6600 Drive Tray – Rear View

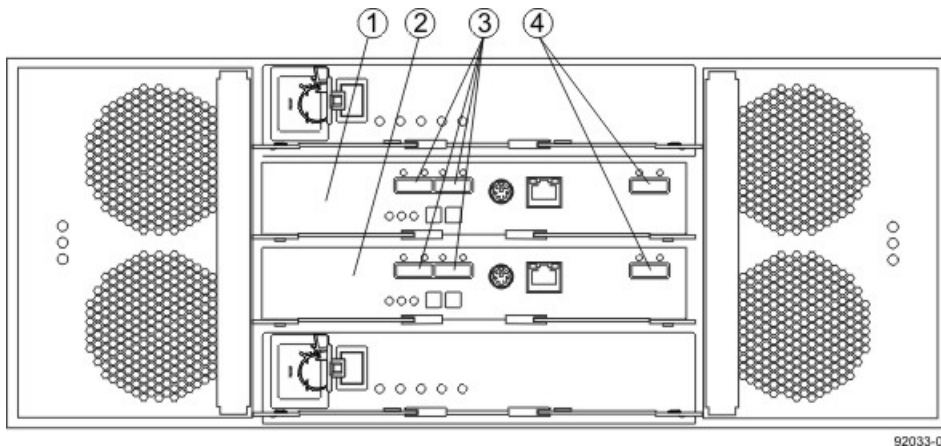

- 1. ESM A
- 2. ESM B
- 3. SAS IN Connectors
- 4. SAS Expansion (Out) Connectors

Things to Know – Drive Tray Cabling Configurations for the CE5400-24 Controller-Drive Tray and the CE5400-12 Controller-Drive Tray

The figures in this section show representative cabling configurations. The configurations shown guarantee that redundant data paths exist between the controller-drive tray and all attached drive trays in a storage array. The CE5400-24 controller-drive tray and the CE5400-12 controller-drive tray can be cabled to DE1600 drive trays, DE5600 drive trays, DE6600 drive trays, or various combinations of those three models of drive tray.

One CE5400-24 or CE5400-12 Controller-Drive Tray and One DE1600 Drive Tray or DE5600 Drive Tray

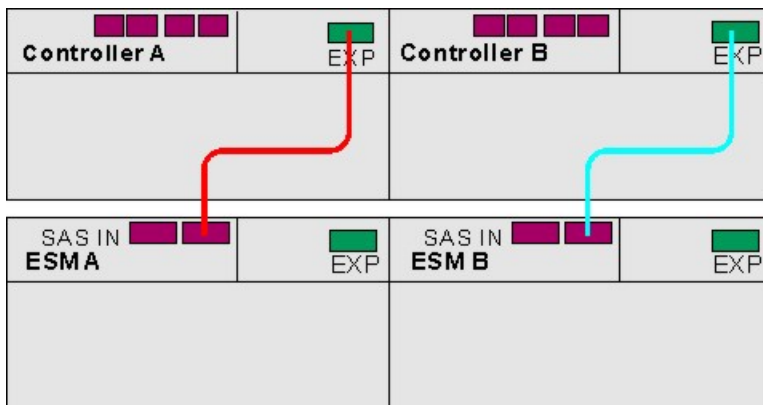

50012-03

One CE5400-24 or CE5400-12 Controller-Drive Tray and Two DE1600 Drive Trays or DE5600 Drive Trays

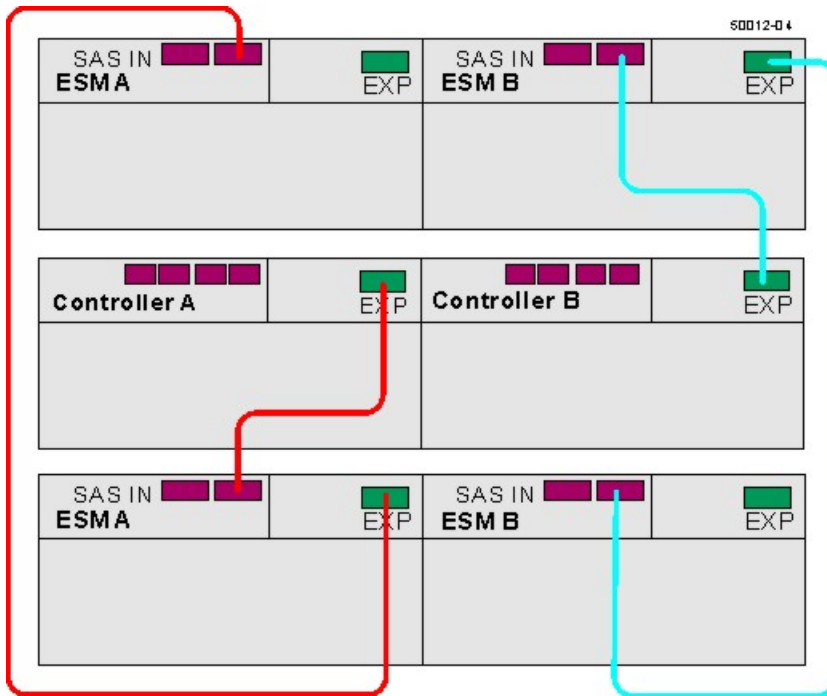

One CE5400-24 or CE5400-12 Controller-Drive Tray and One DE6600 Drive Tray

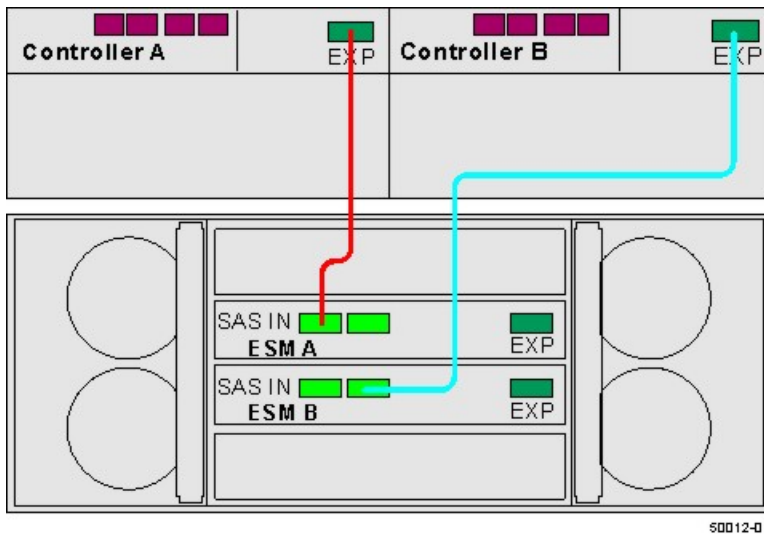

One CE5400-24 or CE5400-12 Controller-Drive Tray and Two DE6600 Drive Trays

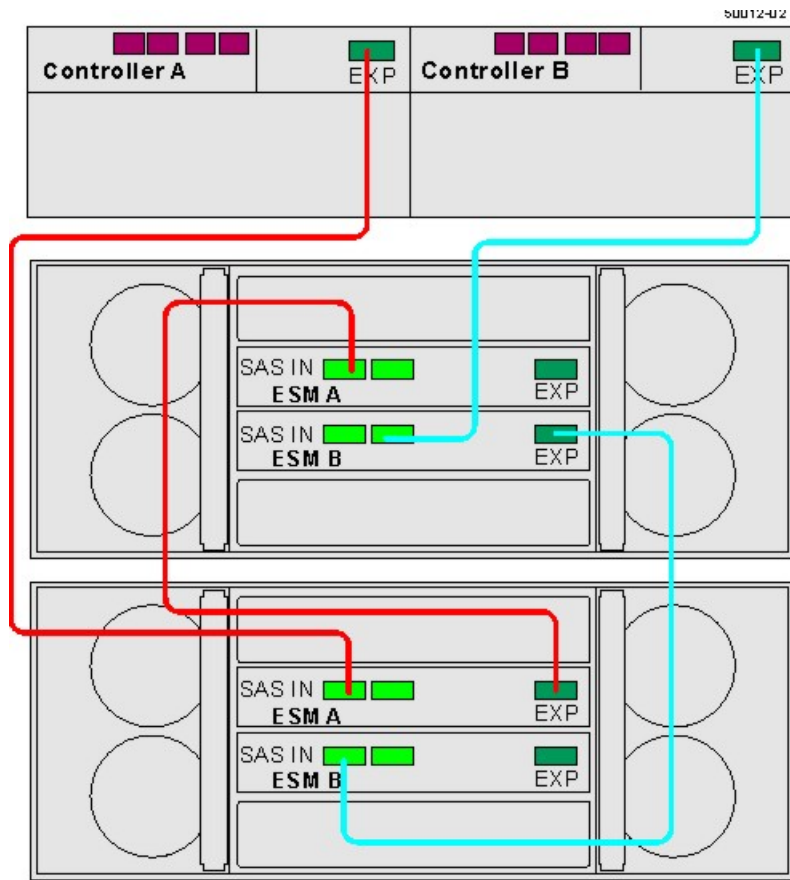

One CE5400-24 or CE5400-12 Controller-Drive Tray and Seven or More Drive Trays

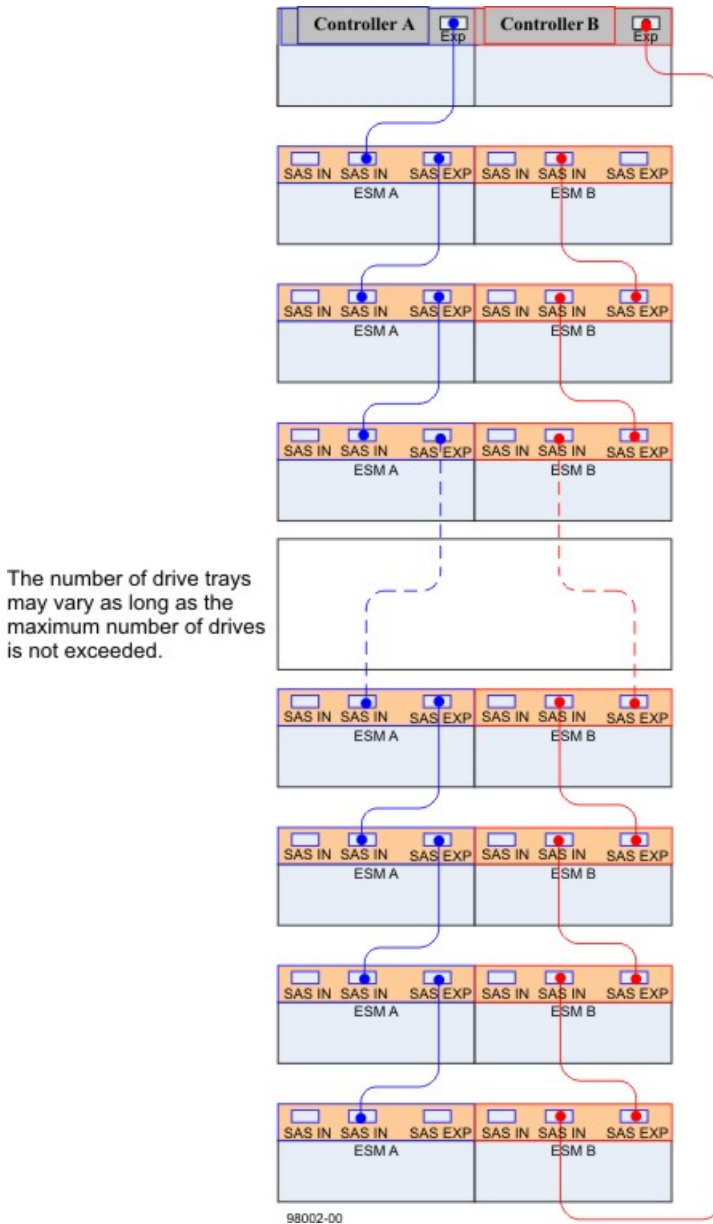

Things to Know – Drive Tray Cabling Configurations for the CE5400-60 Controller-Drive Tray

The figures in this section show representative cabling configurations. The configurations shown guarantee that redundant data paths exist between the controller-drive tray and all attached drive trays in a storage array. The CE5400-60 controller-drive tray can be cabled to DE1600 drive trays, DE5600 drive trays, DE6600 drive trays, or various combinations of those three models of drive tray.



WARNING (W15) Risk of bodily injury – An empty tray weighs approximately 56.7 kg (125 lb). Three persons are required to safely move an empty tray. If the tray is populated with components, a mechanized lift is required to safely move the tray.

NOTE Install the CE5400-60 controller-drive tray at the bottom of the cabinet so that the cabinet does not become top heavy. A top-heavy cabinet has a greater risk of falling over.

One CE5400-60 Controller-Drive Tray and One DE1600 Drive Tray or DE5600 Drive Tray

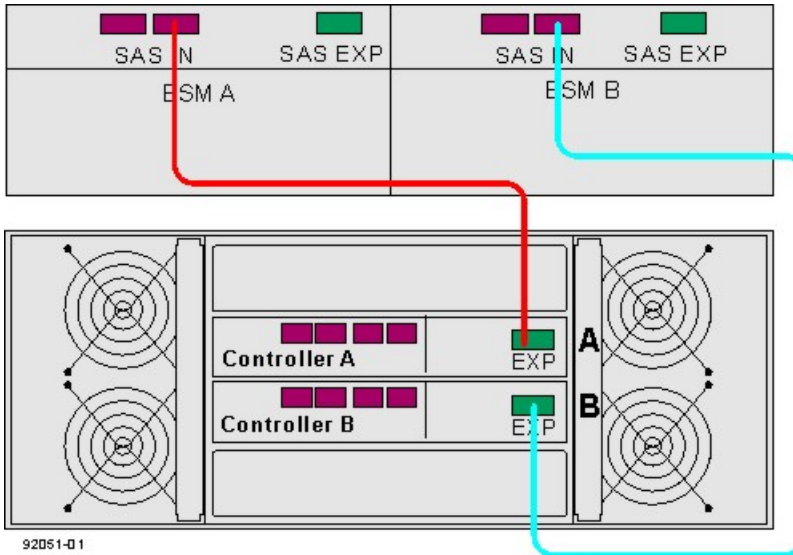

One CE5400-60 Controller-Drive Tray and Two DE1600 Drive Trays or DE5600 Drive Trays

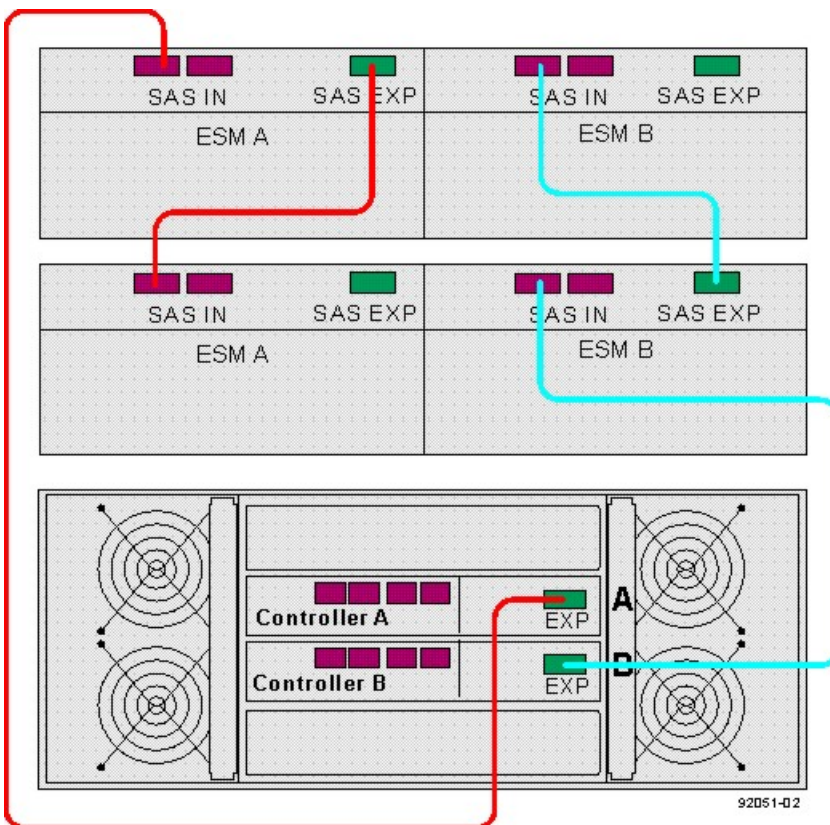

The following figures show the SAS ports on a DE6600 drive tray. You may connect either of the SAS ports labeled SAS 1 and SAS 2 to the SAS expansion port on another drive tray or on a controller-drive tray. Do not make connections to both the SAS 1 port and the SAS 2 port on the same ESM.



WARNING (W15) Risk of bodily injury – An empty tray weighs approximately 56.7 kg (125 lb). Three persons are required to safely move an empty tray. If the tray is populated with components, a mechanized lift is required to safely move the tray.



IMPORTANT If the storage array includes DE6600 drive trays, install those drive trays beginning from the bottom of the rack so that the rack does not become top-heavy. A top-heavy rack has a greater risk of falling over.

SAS Ports on a DE6600 Drive Tray

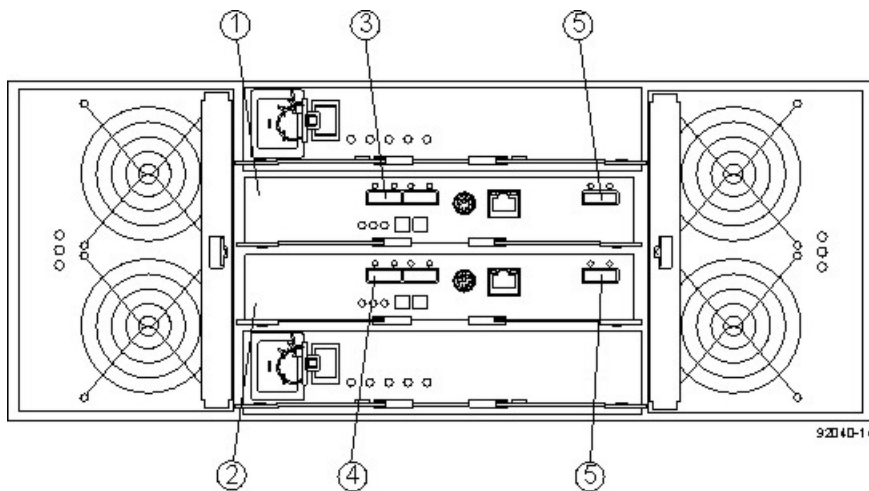

1. ESM A
2. ESM B
3. SAS In Port
4. SAS In Port
5. SAS Expansion (Out) Ports

One CE5400-60 Controller-Drive Tray and One DE6600 Drive Tray

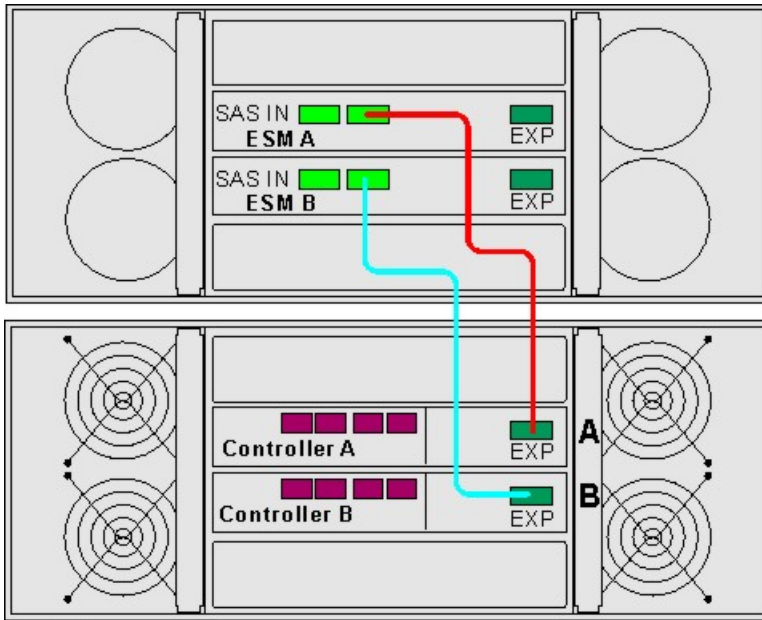

92051-03

One CE5400-60 Controller-Drive Tray and Two DE6600 Drive Trays

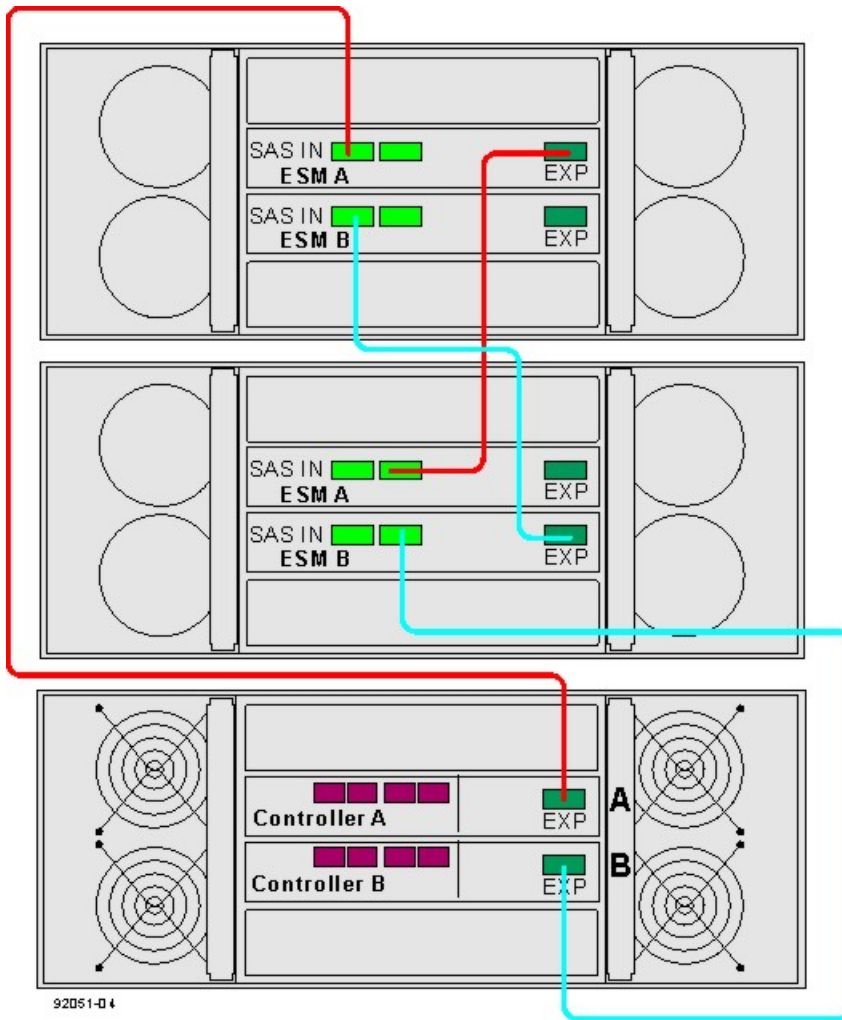

The following figure shows how the cabling pattern can be continued for additional drive trays until the 15 drive tray limit or the limit on the total number of drives in the storage array is reached. The figure uses the schematic representation for DE1600 drive trays or DE5600 drive trays. However, DE6600 drive trays can be included in the storage array as long as the same cabling pattern, connecting SAS expansion ports to SAS In ports, is followed.



NOTE The cabling pattern is independent of the physical location of the trays in the rack. If the storage array includes DE6600 drive trays, install those drive trays beginning from the bottom of the rack so that the rack does not become top-heavy. A top-heavy rack has a greater risk of falling over.

One CE5400-60 Controller-Drive Tray and Seven or More Drive Trays

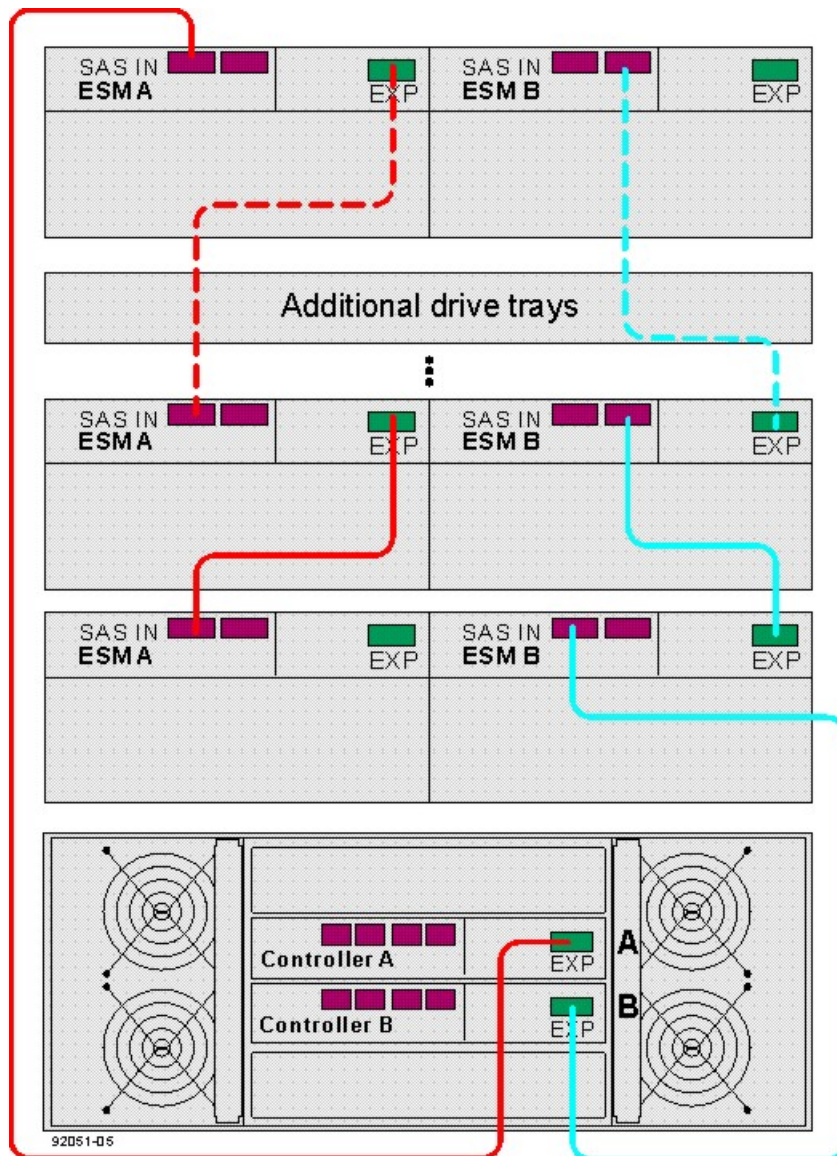

Procedure – Connecting the Drive Trays to the CE5400 Controller-Drive Tray

You will need two SAS cables for each drive tray that you connect to the controller-drive tray. These general rules apply:

- All cables connect a SAS Expansion (Out) port at one end to a SAS In port at the other end. Never connect a SAS Expansion (Out) port to another SAS Expansion (Out) port. Never connect a SAS In port to another SAS In port .
- No ESM can have cables connected to both of its SAS In ports.
- The drive trays in the chain of connections from controller A are in the reverse order from those whose connections start from controller B. That is, the last drive tray in the chain from controller A must be the first drive tray in the chain from controller B.



NOTE It does not matter which of the two SAS In ports on an ESM you use for a connection.



NOTE Some SAS ports might have a black plastic plug installed. Remove the plug before you attach a cable to the port.

As you install each cable, attach labels to the cable with the following information:

- The controller ID (for example, controller A)
- The ESM ID (for example, ESM A)
- The ESM connector (In or Out)
- The drive tray ID

For example, if you are connecting controller A to the SAS In port on ESM A in drive tray 1, the label on the controller end of the cable will have this information:

CtA-Dch1, Dm1-ESM_A (left), In - Controller End

The label on the drive tray end of the cable will have this information:

Dm1-ESM_A (left), In, CtrlA

1. Attach a cable between the SAS Expansion (Out) connector on controller A in the controller-drive tray and a SAS In connector on ESM A in the first drive tray.
2. Are you adding more drive trays?
 - **Yes** – Go to step 3.
 - **No** – Go to step 5.
3. Attach a cable between the SAS Expansion (Out) connector on ESM A of the previous drive tray that you cabled and a SAS In connector on ESM A in the next drive tray.
4. Are you adding more drive trays?
 - **Yes** – Go to step 2.
 - **No** – Go to step 5.
5. Attach a cable between the SAS Expansion (Out) connector on controller B in the controller-drive tray and a SAS In connector on ESM B in the last drive tray.
6. Are you adding more drive trays?
 - **Yes** – Go to step 7.
 - **No** – Stop.
7. Attach a cable between the SAS Expansion (Out) connector on ESM B of the previous drive tray that you cabled and a SAS In connector on ESM B in the next drive tray (in reverse order from step 3).
8. Are you adding more drive trays?
 - **Yes** – Go to step 7.
 - **No** – You are finished with the procedure.

Step 8 – Connecting the Ethernet Cables

Key Terms

in-band management

A method to manage a storage array in which a storage management station sends commands to the storage array through the host input/output (I/O) connection to the controller.

out-of-band management

A method to manage a storage array in which a storage management station sends commands to the storage array through the Ethernet connections on the controller.

Things to Know – Connecting Ethernet Cables



ATTENTION Risk of security breach – Connect the Ethernet ports on the controller tray to a private network segment behind a firewall. If the Ethernet connection is not protected by a firewall, your storage array might be at risk of being accessed from outside of your network.

- Ethernet port 2 on each controller is reserved for access by your Customer and Technical Support representative.
- In limited situations, you may choose to attach the storage management station directly to the controller-drive tray. For this configuration, you must use an Ethernet crossover cable. An Ethernet crossover cable is a special cable that reverses the pin contacts between the two ends of the cable.

Procedure – Connecting Ethernet Cables

Perform these steps to connect Ethernet cables for out-of-band management. If you use only in-band management, skip these steps.

1. Connect one end of an Ethernet cable into the Ethernet port 1 on controller A.
2. Connect the other end to the applicable network connection.
3. Repeat step 1 through step 2 for controller B.

Step 9 – Connecting the Power Cords

The CE5400-24 controller-drive tray, the CE5400-12 controller-drive tray, the DE1600 drive tray, and the DE5600 drive tray can have either standard power connections to an AC power source or the optional connections to a DC power source (–48 VDC).

NOTE Make sure that you do not turn on the power to the controller-drive tray or the connected drive trays until this documentation instructs you to do so. For the correct procedure for turning on the power, see [Step 10 – Turning on the Power and Checking for Problems in a CE5400 Controller-Drive Tray Configuration](#).

Things to Know – AC Power Cords

- For each AC power connector on the drive tray, make sure that you use a separate power source in the cabinet. Connecting to independent power sources maintains power redundancy.
- To ensure proper cooling and assure availability, the drive trays always use two power supplies.
- You can use the power cords shipped with the controller-drive tray with typical outlets used in the destination country, such as a wall receptacle or an uninterruptible power supply (UPS). These power cords, however, are not intended for use in most EIA-compliant cabinets.

Things to Know – DC Power Cords

If your controller-drive trays have the DC power option installed, review the following information.

DC Power Cable

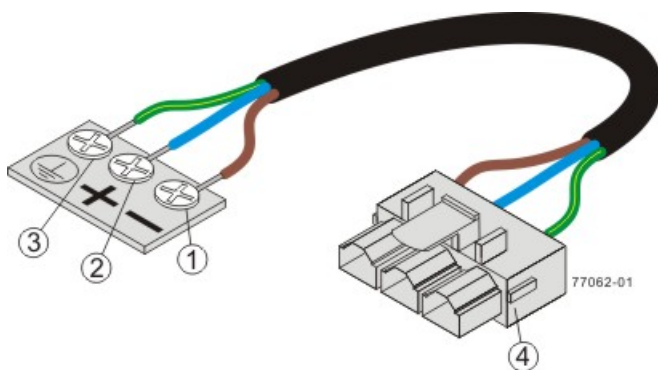

- Supply (negative), brown wire, –48 VDC
- Return (positive), blue wire
- Ground, green/yellow wire
- DC power connector

- Each power-fan canister has two DC power connectors. Be sure to use a separate power source for each power-fan canister in the drive tray to maintain power redundancy. You may, optionally, connect each DC power connector on the same power-fan canister to a different source for additional redundancy.
- A two-pole 30-amp circuit breaker is required between the DC power source and the drive tray for over-current and short-circuit protection.

WARNING (W14) Risk of bodily injury – A qualified service person is required to make the DC power connection according to NEC and CEC guidelines.

Procedure – Connecting AC Power Cords

1. Make sure that the circuit breakers in the cabinet are turned off.
2. Make sure that both of the Power switches on the controller-drive tray are turned off.
3. Connect the primary power cords from the cabinet to the external power source.
4. Connect a cabinet interconnect power cord (or power cords specific to your particular cabinet) to the AC power connector on each power canister in the drive tray.
5. If you are installing other drive trays in the cabinet, connect a power cord to each power canister in the drive trays.

Procedure – Connecting DC Power Cords



WARNING (W14) Risk of bodily injury – A qualified service person is required to make the DC power connection according to NEC and CEC guidelines.



NOTE Make sure that you do not turn on power to the controller-drive tray until this guide instructs you to do so. For the proper procedure for turning on the power, see [Step 10 – Turning on the Power and Checking for Problems in a CE5400 Controller-Drive Tray Configuration](#).



NOTE Before turning off any power switches on a DC-powered controller-drive tray, you must disconnect the two-pole 20-amp circuit breaker.

1. Disconnect the two-pole 20-amp circuit breaker for the storage array.
2. Make sure that all of the DC power switches on the DC-powered controller-drive tray are turned off.
3. Make sure that all of the DC power switches on the DC-powered drive trays are turned off.
4. Connect the DC power connector cables to the DC power connectors on the rear of the controller-drive tray and the drive trays.



NOTE The three source wires on the DC power connector cable (–48 VDC) connect the controller-drive tray to centralized DC power plant equipment, typically through a bus bar located above the cabinet.



NOTE It is not mandatory that the second DC power connection on each of the drive tray's DC power-fan canisters be connected. The second DC power connection is for additional redundancy only and may be connected to a second DC power bus.

5. Have a qualified service person connect the other end of the DC power connector cables to the DC power plant equipment as follows:
 - a. Connect the brown –48 VDC supply wire to the negative terminal.
 - b. Connect the blue return wire to the positive terminal.
 - c. Connect the green/yellow ground wire to the ground terminal.

Step 10 – Turning on the Power and Checking for Problems in a CE5400 Controller-Drive Tray Configuration

After you complete this task, you can install the software and perform basic configuration tasks on your storage array. Continue with the *Initial Configuration and Software Installation* in these electronic document topics or to the PDF that is available on the SANtricity ES Storage Manager Installation DVD.

Procedure – Turning On the Power to the Storage Array and Checking for Problems in a CE5400 Controller-Drive Tray Configuration

 **NOTE** You must turn on the power to all of the connected drive trays before you turn on the power for the controller-drive tray. Performing this action makes sure that the controllers recognize each attached drive tray.

 **NOTE** While the power is being applied to the trays, the LEDs on the front and the rear of the trays come on and go off intermittently.

1. Turn on both Power switches on each drive tray that is attached to the controller-drive tray. Depending on your configuration, it can take several minutes for each drive tray to complete the power-on process.
-

 **NOTE** Before you go to step 2, check the LEDs on the drive trays to verify that the power was successfully applied to all of the drive trays. Wait 30 seconds after turning on the power to the drive trays before turning on the power to the controller-drive tray.

2. Turn on both Power switches on the rear of the controller-drive tray. Depending on your configuration, it can take several minutes for the controller-drive tray to complete the power-on process.
3. Check the LEDs on the front and the rear of the controller-drive tray and the attached drive trays.
4. If you see any amber LEDs, make a note of their location.

Things to Know – Service Action Allowed LEDs

Each controller canister, power-fan canister, and battery canister has a Service Action Allowed LED. The Service Action Allowed LED lets you know when you can remove a canister safely.

 **ATTENTION Possible loss of data access** – Never remove a controller canister, a power-fan canister, or a battery canister unless the appropriate Service Action Allowed LED is on.

If a controller canister or a power-fan canister fails and must be replaced, the Service Action Required (Fault) LED on that canister comes on to indicate that service action is required. The Service Action Allowed LED also comes on if it is safe to remove the canister. If data availability dependencies exist or other conditions that dictate a canister should not be removed, the Service Action Allowed LED stays off.

The Service Action Allowed LED automatically comes on or goes off as conditions change. In most cases, the Service Action Allowed LED comes on when the Service Action Required (Fault) LED comes on for a canister.

 **NOTE** If the Service Action Required (Fault) LED comes on but the Service Action Allowed LED is off for a particular canister, you might need to service another canister first. Check your storage management software to determine the action that you should take.

Things to Know – LEDs on the CE5400 Controller-Drive Trays

The following topics provide details on the LEDs found on the CE5400 controller-drive trays.

LEDs on the Left End Cap

LEDs on the Left End Cap – CE5400-24 Controller-Drive Tray and CE5400-12 Controller-Drive Tray

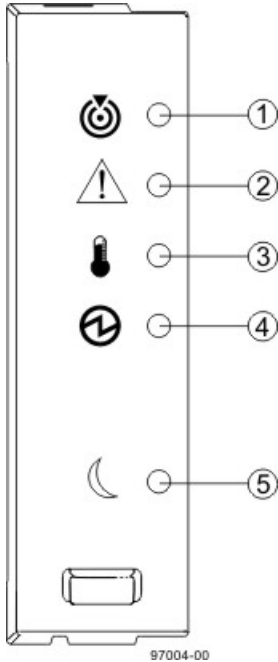

1. Controller-Drive Tray Locate LED
2. Controller-Drive Tray Service Action Required LED
3. Controller-Drive Tray Over-Temperature LED
4. Controller-Drive Tray Power LED
5. Controller-Drive Tray Standby Power LED

LEDs on the Left End Cap – CE5400-60 Controller-Drive Tray

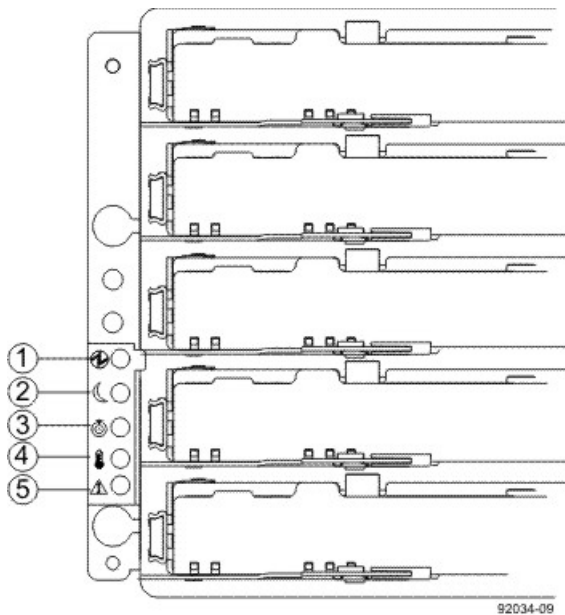

1. Controller-Drive Tray Locate LED
2. Controller-Drive Tray Service Action Required LED
3. Controller-Drive Tray Over-Temperature LED
4. Controller-Drive Tray Power LED
5. Controller-Drive Tray Standby Power LED

LEDs on the Left End Caps

| Location | LED | Color | On | Off |
|----------|--|-------|---|---|
| 1 | Controller-Drive Tray Locate | White | Identifies a controller-drive tray that you are trying to find. | Normal status. |
| 2 | Service Action Required | Amber | A component within the controller-drive tray needs attention. | Normal status. |
| 3 | Controller-Drive Tray Over-Temperature | Amber | The temperature of the controller-drive tray has reached an unsafe level. | Normal status. |
| 4 | Power | Green | Power is present. | Power is not present. |
| 5 | Standby Power | Green | The controller-drive tray is in Standby Power mode. | The controller-drive tray is not in Standby Power mode. |

LEDs on the Drive

LEDs on the Drive – CE5400-24 Controller-Drive Tray and CE5400-12 Controller-Drive Tray

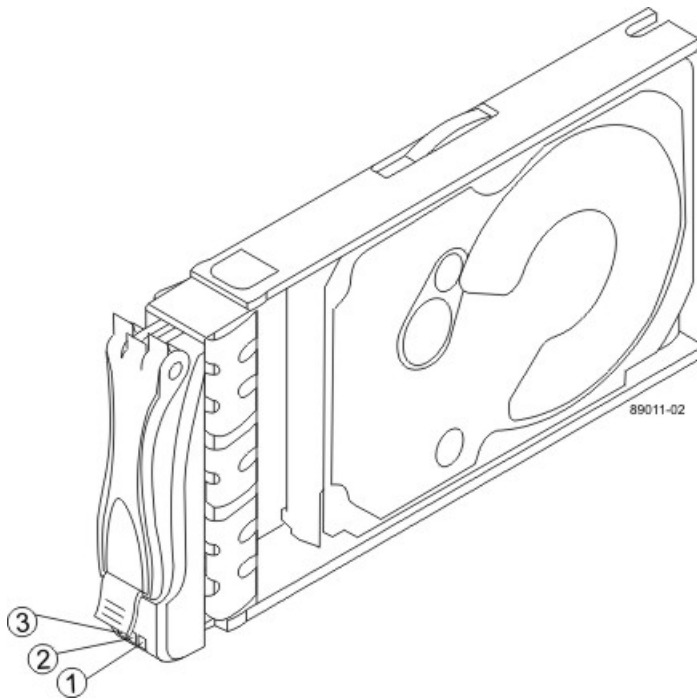

1. Drive Power LED
2. Drive Service Action Required LED
3. Drive Service Action Allowed LED

LEDs on the Drive

| Location | LED | Color | On | Blinking | Off |
|----------|-------------------------------|-------|--|-------------------------------------|---|
| 1 | Drive Power | Green | The power is turned on, and the drive is operating normally. | Drive I/O activity is taking place. | The power is turned off. |
| 2 | Drive Service Action Required | Amber | An error has occurred. | | Normal status. |
| 3 | Drive Service Action Allowed | Blue | The drive canister can be removed safely from the controller-drive tray. | | The drive canister cannot be removed safely from the controller-drive tray. |

Drive State Represented by the LEDs

| Drive State | Drive Power LED (Green) | Drive Service Action Required LED (Amber) |
|---|-------------------------|---|
| Power is not applied. | Off | Off |
| Normal operation – The power is turned on, but drive I/O activity is not occurring. | On | Off |
| Normal operation – Drive I/O activity is occurring. | Blinking | Off |
| Service action required – A fault condition exists, and the drive is offline. | On | On |

LEDs on the Controller Canister Main Faceplate

LEDs on the Controller Canister Main Faceplate

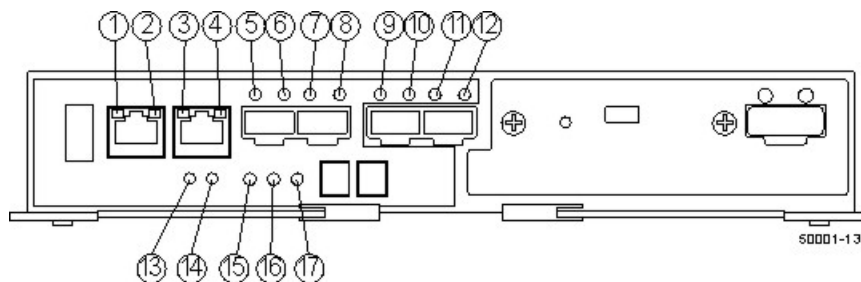

1. Ethernet Connector 1 Link Rate LED
2. Ethernet Connector 1 Link Active LED
3. Ethernet Connector 2 Link Rate LED
4. Ethernet Connector 1 Link Active LED
5. Fibre Channel Link 1 LED 0
6. Fibre Channel Link 1 LED 1
7. Fibre Channel Link 2 Up LED
8. Fibre Channel Link 2 Active LED
9. Fibre Channel Link 3 Up LED
10. Fibre Channel Link 3 Active LED
11. Fibre Channel Link 4 Up LED
12. Fibre Channel Link 4 Active LED
13. Battery Service Action Required LED
14. Battery Charging LED
15. Controller Service Action Allowed LED
16. Controller Service Action Required LED
17. Cache Active LED

LEDs on the Controller Canister Main Faceplate

| Location | LED | Color | On | Off |
|----------|------------------------------------|-------|----------------------------|---------------------------|
| 1 | Ethernet Connector 1 Link Rate LED | Green | There is a 100BASE-T rate. | There is a 10BASE-T rate. |

| Location | LED | Color | On | Off |
|----------|---|-------|---|---------------------------|
| 2 | Ethernet Connector 1 Link Active LED | Green | The link is up (the LED blinks when activity is occurring). | The link is not active. |
| 3 | Ethernet Connector 2 Link Rate LED | Green | There is a 100BASE-T rate. | There is a 10BASE-T rate. |
| 4 | Ethernet Connector 2 Link Active LED | Green | The link is up (the LED blinks when there is activity). | The link is not active. |
| 5 and 6 | Host connection 1 link active and data rate | | | |
| | LED 0 off and LED 1 off | Green | The link is not active | |
| | LED 0 on and LED 1 off | Green | Date rate 2 Gb/s | |
| | LED 0 off and LED 1 on | Green | Date rate 4 Gb/s | |
| | LED 0 on and LED 1 on | Green | Date rate 8 Gb/s | |
| 7 and 8 | Host connection 2 link active and data rate | | | |
| | LED 0 off and LED 1 off | Green | The link is not active | |
| | LED 0 on and LED 1 off | Green | Date rate 2 Gb/s | |
| | LED 0 off and LED 1 on | Green | Date rate 4 Gb/s | |
| | LED 0 on and LED 1 on | Green | Date rate 8 Gb/s | |
| 9 and 10 | Host connection 3 link active and data rate | | | |
| | LED 0 off and LED 1 off | Green | The link is not active | |
| | LED 0 on and LED 1 off | Green | Date rate 2 Gb/s | |

| Location | LED | Color | On | Off |
|---|---|-------|---|---|
| | LED 0 off and LED 1 on | Green | Data rate 4 Gb/s | |
| | LED 0 on and LED 1 on | Green | Data rate 8 Gb/s | |
| 11 and 12 | Host connection 4 link active and data rate | | | |
| | LED 0 off and LED 1 off | Green | The link is not active | |
| | LED 0 on and LED 1 off | Green | Data rate 2 Gb/s | |
| | LED 0 off and LED 1 on | Green | Data rate 4 Gb/s | |
| | LED 0 on and LED 1 on | Green | Data rate 8 Gb/s | |
| 13 | Battery Service Action Required LED | Amber | The battery in the controller canister has failed. | Normal status. |
| 14 | Battery Charging LED | Green | The battery is fully charged. The LED blinks when the battery is charging. | The controller canister is operating without a battery or the existing battery has failed. |
| 15 | Controller Service Action Allowed LED | Blue | The controller canister can be removed safely from the controller-drive tray. | The controller canister cannot be removed safely from the controller-drive tray. |
| 16 | Controller Service Action Required LED | Amber | A fault exists within the controller canister. | Normal status. |
| 17 | Cache Active LED | Green | Cache is active.* | Cache is inactive or the controller canister has been removed from the controller-drive tray. |
| * After an AC power failure, this LED blinks while cache offload is in process. | | | | |

LEDs on the Controller Canister Host Interface Card Subplates

CE5400 Right-Rear Subplate with an Fibre Channel Host Interface Card

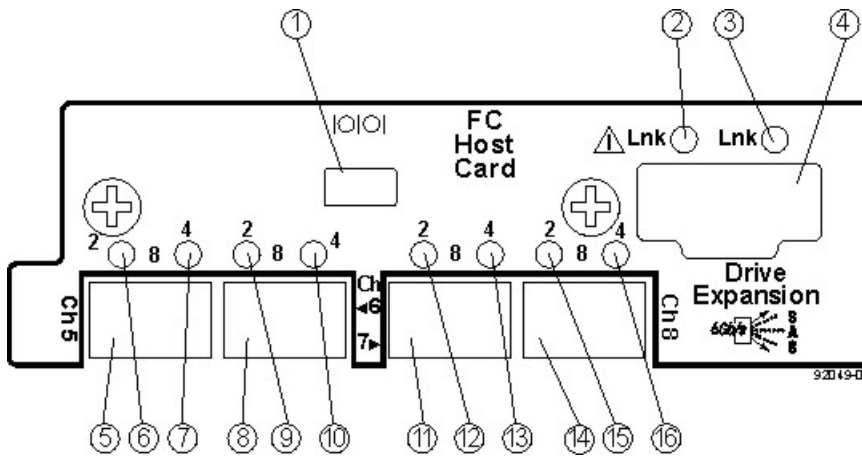

1. Mini USB Connector
2. SAS Expansion Fault LED
3. SAS Expansion Active LED
4. SAS Expansion SFF-8088 Port Connector
5. FC Host Interface Card Connector 5
6. Host Interface Card Link 5 LED 0
7. Host Interface Card Link 5 LED 1
8. FC Host Interface Card Connector 6
9. Host Interface Card Link 6 LED 0
10. Host Interface Card Link 6 LED 1
11. FC Host Interface Card Connector 7
12. Host Interface Card Link 7 LED 0
13. Host Interface Card Link 7 LED 1
14. FC Host Interface Card Connector 8
15. Host Interface Card Link 8 LED 0
16. Host Interface Card Link 8 LED 1

LEDs on the Controller Canister Fibre Channel Host Interface Card Subplates*

| Location | LED | Color | On | Off |
|----------|-------------------------|-------|---|-------------------------|
| 2 | Expansion Fault LED | Amber | At least one of the four PHY is working, but another PHY cannot establish the same link to the device connected to the Expansion OUT connector. | Normal status. |
| 3 | Expansion Active LED | Green | At least one of the four PHYs in the OUT connector is working and a link has been made to the device connected to the Expansion connector. | The link is not active. |
| 6 and 7 | LED 0 off and LED 1 off | Green | Link down | The link is not active |

| Location | LED | Color | On | Off |
|-----------|-------------------------|-------|-------------|------------------------|
| | LED 0 on and LED 1 off | Green | Link active | Date rate 2 Gb/s |
| | LED 0 off and LED 1 on | Green | Link active | Date rate 4 Gb/s |
| | LED 0 on and LED 1 on | Green | Link active | Date rate 8 Gb/s |
| 9 and 10 | LED 0 off and LED 1 off | Green | Link down | The link is not active |
| | LED 0 on and LED 1 off | Green | Link active | Date rate 2 Gb/s |
| | LED 0 off and LED 1 on | Green | Link active | Date rate 4 Gb/s |
| | LED 0 on and LED 1 on | Green | Link active | Date rate 8 Gb/s |
| 12 and 13 | LED 0 off and LED 1 off | Green | Link down | The link is not active |
| | LED 0 on and LED 1 off | Green | Link active | Date rate 2 Gb/s |
| | LED 0 off and LED 1 on | Green | Link active | Date rate 4 Gb/s |
| | LED 0 on and LED 1 on | Green | Link active | Date rate 8 Gb/s |
| 15 and 16 | LED 0 off and LED 1 off | Green | Link down | The link is not active |
| | LED 0 on and LED 1 off | Green | Link active | Date rate 2 Gb/s |
| | LED 0 off and LED 1 on | Green | Link active | Date rate 4 Gb/s |
| | LED 0 on and LED 1 on | Green | Link active | Date rate 8 Gb/s |
| | | | | |

CE5400 Right-Rear Subplate with an InfiniBand Host Interface Card

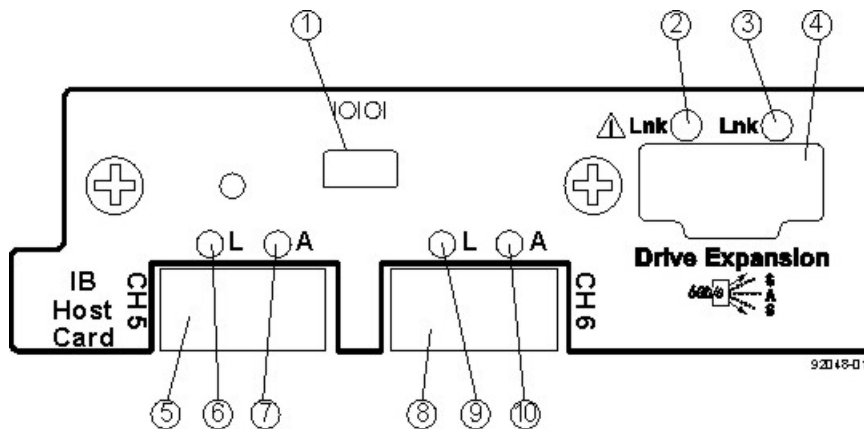

1. Mini USB Connector
2. SAS Expansion Fault LED
3. SAS Expansion Active LED
4. SAS Expansion SFF-8088 Port Connector
5. IB Host Interface Card Connector 1
6. IB Host Interface Card Physical Link 1 LED (Green)
7. IB Host Interface Card Logical Link 1 LED (Amber)
8. IB Host Interface Card Connector 2
9. IB Host Interface Card Physical Link 2 LED (Green)
10. IB Host Interface Card Logical Link 2 LED (Amber)

LEDs on the Controller Canister InfiniBand Host Interface Card Subplates*

| Location | LED | Color | On | Off |
|----------|-------------------------------------|-------|---|-------------------------------|
| 2 | Expansion Fault LED | Amber | At least one of the four PHY is working, but another PHY cannot establish the same link to the device connected to the Expansion OUT connector. | Normal status. |
| 3 | Expansion Active LED | Green | At least one of the four PHYs in the OUT connector is working and a link has been made to the device connected to the Expansion connector. | The link is not active. |
| 6 | Host connection 1 physical link LED | Green | Physical link up | Physical link error |
| 7 | Host connection 1 logical link LED | | | |
| | | On | Amber | Logical link up - no activity |

| Location | LED | Color | On | Off |
|----------|---|-------|---------------------------------|---------------------|
| | Blinking | Amber | Logical link up - with activity | |
| | Off | Amber | Logical link down | |
| 9 | Host connection 2 physical link LED | Green | Physical link up | Physical link error |
| 10 | Host connection 2 logical link LED | | | |
| | On | Amber | Logical link up - no activity | |
| | Blinking | Amber | Logical link up - with activity | |
| | Off | Amber | Logical link down | |

LEDs on the Power-Fan Canister

LEDs on the Power-Fan Canister – CE5400-24 Controller-Drive Tray and CE5400-12 Controller-Drive Tray

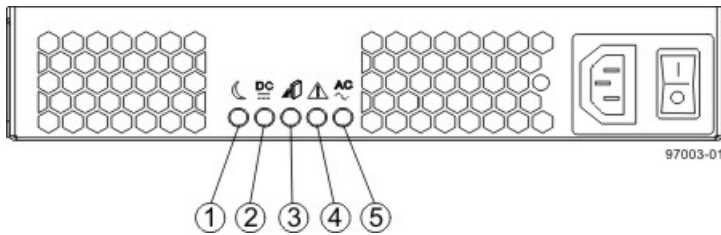

1. Standby Power LED
2. Power-Fan DC Power LED
3. Power-Fan Service Action Allowed LED
4. Power-Fan Service Action Required LED
5. Power-Fan AC Power LED

LEDs on the Power-Fan Canister – CE5400-60 Controller-Drive Tray

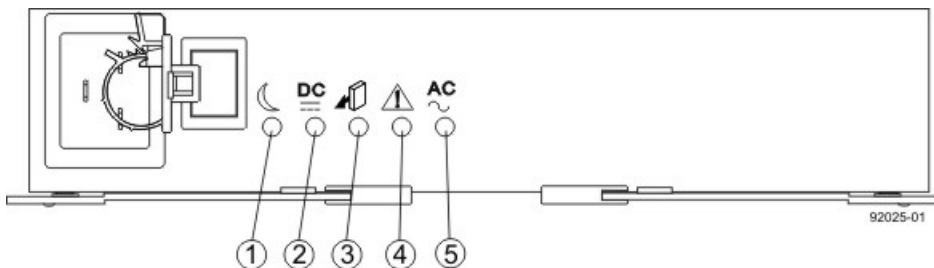



1. Standby Power LED
2. Power-Fan DC Power LED
3. Power-Fan Service Action Allowed LED
4. Power-Fan Service Action Required LED
5. Power-Fan AC Power LED







LEDs on the Power-Fan Canister





| Location | LED | Color | On | Off |
|----------|-----------------------------------|-------|--|---|
| 1 | Standby Power | Green | The controller-drive tray is in Standby mode, and DC power is not available. | The controller-drive tray is not in Standby mode, and DC power is available. |
| 2 | Power-Fan DC Power | Green | DC power from the power-fan canister is available. | DC power from the power-fan canister is not available. |
| 3 | Power-Fan Service Action Allowed | Blue | The power-fan canister can be removed safely from the controller-drive tray. | The power-fan canister cannot be removed safely from the controller-drive tray. |
| 4 | Power-Fan Service Action Required | Amber | A fault exists within the power-fan canister. | Normal status. |
| 5 | Power-Fan AC Power | Green | AC power to the power-fan canister is present. | AC power to the power-fan canister is not present. |

Things to Know – General Behavior of the LEDs on the CE5400 Controller-Drive Trays

LED Symbols and General Behavior

| LED | Symbol | Location (Canisters) | Function |
|---------------|---|----------------------|---|
| Power |  | Power-fan | <ul style="list-style-type: none"> ▪ On – The controller has power. ▪ Off – The controller does not have power. <p>NOTE – The controller canisters do not have a Power LED. They receive their power from the power supplies inside the power-fan canisters.</p> |
| Battery Fault |  | Battery | <ul style="list-style-type: none"> ▪ On – The battery is missing or has failed. ▪ Off – The battery is operating normally. ▪ Blinking – The battery is charging. |

| LED | Symbol | Location (Canisters) | Function |
|---------------------------------|---|---|---|
| Service Action Allowed |  | Drive (left LED, no symbol) Power-fan Controller Battery | On – You can remove the canister safely. |
| Service Action Required (Fault) |  | Drive Front bezel of the controller-drive tray | On – When the controller-drive tray LED is on, the cable is attached and at least one lane has a link up status, but at least one lane has a link down status. Off – One of the following conditions exists: <ul style="list-style-type: none"> ▪ No cable is attached. ▪ A cable is attached, and all lanes have a link up status. ▪ A cable is attached, and all lanes have a link down status. |
| Service Action Required (Fault) |  | Controller Power-fan canister | On – The controller or the power-fan canister needs attention. Off – The controller and the power-fan canister are operating normally. |
| Locate |  | Front bezel of the controller-drive tray | On – Assists in locating the tray. |
| Host Channel Connection |  | Controller | The status of the host channel is indicated: <ul style="list-style-type: none"> ▪ “L” LED on – A link is established. ▪ “A” LED on – Activity (data transfer) is present. |
| Cache Active |  | Controller | The activity of the cache is indicated: <ul style="list-style-type: none"> ▪ On – Data is in the cache. |

| LED | Symbol | Location (Canisters) | Function |
|---|---|---|---|
| | | | <ul style="list-style-type: none"> Off – No data is in the cache. |
| Controller-Drive Tray Over-Temperature |  | Front bezel on the controller-drive tray | <p>On – The temperature of the controller-drive tray has reached an unsafe condition.</p> <p>Off – The temperature of the controller-drive tray is within operational range.</p> |
| Controller-Drive Tray Standby Power |  | Front bezel on the controller-drive tray | <p>On – The controller-drive tray is in standby mode and the main DC power is off.</p> <p>Off – The controller-drive tray is not in standby mode and the main DC power is on.</p> |
| Seven-Segment ID Diagnostic Display |  | Controller | <p>The tray ID or a diagnostic code is indicated (see “Things to Know – Dynamic Display Sequence Definitions on the Seven-Segment Display”). For example, if some of the cache memory dual inline memory modules (DIMMs) are missing in a controller, error code L8 appears in the diagnostic display (see Things to Know – Lock-Down Codes for the CE5400 Controller-Drive Trays).</p> |
| AC Power | AC  | Power-fan NOTE – The LED is directly above or below the AC power switch and the AC power connector. | Indicates that the power supply is receiving AC power input. |
| DC Power (CE5400-24 and CE5400-12 only) | DC  | Power-fan NOTE – The LED is directly above or below the DC power switch and the DC power connector. | Indicates that the power supply is receiving DC power input. |

| LED | Symbol | Location (Canisters) | Function |
|--------------------------------------|---|----------------------|--|
| Ethernet Speed and Ethernet Activity |  | Controller | <p>The speed of the Ethernet ports and whether a link has been established are indicated:</p> <ul style="list-style-type: none"> ▪ Left LED On – 1-Gb/s speed. ▪ Left LED Off – 100BASE-T or 10BASE-T speed. ▪ Right LED On – A link is established. ▪ Right LED Off – No link exists. ▪ Right LED blinking – Activity is occurring. |

Things to Know – Sequence Code Definitions for the CE5400 Controller-Drive Trays

During normal operation, the tray ID display on each controller canister displays the controller-drive tray ID. The Diagnostic LED (lower-digit decimal point) comes on when the display is used for diagnostic codes and goes off when the display is used to show the tray ID.

Sequence Code Definitions for the CE5400 Controller-Drive Trays

| Category | Category Code (See Note 1) | Detail Codes (See Note 2) |
|-------------------|----------------------------|---|
| Startup error | SE+ (see Note 3) | <ul style="list-style-type: none"> ▪ 88+ Power-on default. ▪ dF+ Power-on diagnostic fault. ▪ Sx Power-on Validation Error |
| Operational error | OE+ | Lx+ Lock-down codes. (See note 3.) |
| Operational state | OS+ | <ul style="list-style-type: none"> ▪ OL+ = Offline. (See note 11) ▪ bb+ = Battery backup (operating on batteries). ▪ Cf+ = Component failure. (See note 12.) |
| Component failure | CF+ | <ul style="list-style-type: none"> ▪ dx+ = Processor or cache DIMM. (See note 6.) ▪ Cx = Cache DIMM. (See note 7.) |

| Category | Category Code (See Note 1) | Detail Codes (See Note 2) |
|---|----------------------------|---|
| | | <ul style="list-style-type: none"> ▪ Px+ = Processor DIMM. (See note 8.) ▪ Hx+ = Host interface card. ▪ Fx+ = Flash drive. ▪ b1+ Base Controller Card |
| Diagnostic failure | dE+ | Lx+ = Lock-down code. (See note 3.) |
| Category delimiter | dash+ | The separator between category-detail code pairs is used when more than one category detail code pair exists in the sequence. (See notes 4 and 9.) |
| End-of-sequence delimiter | Blank (see Note 4) | The end-of-sequence delimiter is automatically inserted by the hardware at the end of a code sequence. (See notes 5 and 10.) |
| <p>NOTES:</p> <ol style="list-style-type: none"> 1. xy+ 2-digit code with the Diagnostic light ON. 2. xy- 2-digit code with the Diagnostic light OFF. 3. Lx+ Lock-down codes (see Section 2.1.13. Seven-Segment Display Lock-Down Codes). 4. dash+ All segments off except for the middle segments and with the Diagnostic light ON. 5. blank- All segments off with the Diagnostic light OFF. 6. dx+ Used when there is a single memory system for processor and data cache. 7. Cx+ Used when there are separate processor and data cache memory systems. 8. Px+ Used when there are separate processor and data cache memory systems. 9. Category-Detail separator used when there is more than one category-detail code pair in the sequence. 10. End-of-Sequence indicator automatically inserted by hardware at the end of the sequence. Example: SE+ 88+ blank- (repeat) 11. If a tray ID is being displayed, this sequence is programmed to display if the controller is subsequently held in reset. 12. The tray ID is nominally displayed during normal operation. This operational state is displayed if an internal controller component failure occurs while the controller is online. An additional detail code identifies the failed component as defined for the Component Failure category. This sequence will continue to be displayed even if the controller is subsequently placed offline (held in reset) to service the failed component. | | |

Things to Know – Lock-Down Codes for the CE5400 Controller-Drive Trays

Use the following table to determine the diagnostic lock-down code definitions on the seven-segment display in the controller canister for the CE5400 controller-drive trays.

Supported Diagnostic Lock-Down Codes on the Seven-Segment Display

| Diagnostic Code | Description |
|-----------------|---|
| L0 | The controller types are mismatched, which result in a suspended controller state. |
| L1 | Missing interconnect canister |
| L2 | A persistent memory error has occurred, which results in a suspended controller state. |
| L3 | A persistent hardware error has occurred, which results in a suspended controller state. |
| L4 | A persistent data protection error has occurred, which results in a suspended controller state. |
| L5 | An auto-code synchronization (ACS) failure has been detected, which results in a suspended controller state. |
| L6 | An unsupported host interface card has been detected, which results in a suspended controller state. |
| L7 | A sub-model identifier either has not been set or has been mismatched, which results in a suspended controller state. |
| L8 | A memory configuration error has occurred, which results in a suspended controller state. |
| L9 | A link speed mismatch condition has been detected in either the ESM or the power supply, which results in a suspended controller state. |
| Lb | A host interface card configuration error has been detected, which results in a suspended controller state. |
| LC | A persistent cache backup configuration error has been detected, which results in a suspended controller state. |
| Ld | A mixed cache memory DIMMs condition has been detected, which results in a suspended controller state. |
| LE | Uncertified cache memory DIMM sizes have been detected, which result in a suspended controller state. |
| LF | The controller has locked down in a suspended state with limited symbol support. |
| LH | A controller firmware mismatch been detected, which results in a suspended controller state. |

| Diagnostic Code | Description |
|-----------------|---|
| LL | The controller cannot access either midplane SBB EEPROM, which results in a suspended controller state. |
| Ln | A canister is not valid for a controller, which results in a suspended controller state. |
| LP | Drive port mapping tables are not detected, which results in a suspended controller state. |
| LU | The start-of-day (SOD) reboot limit has been exceeded, which results in a suspended controller state. |

Things to Know – Diagnostic Code Sequences for the CE5400 Controller-Drive Trays

Use the following table to determine the code sequences on the seven-segment display in the controller canister for the CE5400 controller-drive trays. These repeating sequences can be used to diagnose potential problems with the controller tray.

Diagnostic Code Sequences for the CE5400 Controller-Drive Trays

| Displayed Diagnostic Code Sequences | Description |
|-------------------------------------|---|
| SE+ 88+ blank- | One of the following power-on conditions exists: <ul style="list-style-type: none"> ▪ Controller power-on ▪ Controller insertion ▪ Controller inserted while held in reset |
| xy - | Normal operation. |
| OS+ Sd+ blank- | Start-of-day (SOD) processing. |
| OS+ OL+ blank- | The controller is placed in reset while displaying the tray ID. |
| OS+ bb+ blank- | The controller is operating on batteries (cache backup). |
| OS+ CF+ Hx + blank- | A failed host card has been detected. |
| OS+ CF+ Fx + blank- | A failed flash drive has been detected. |
| SE+ dF + blank- | A non-replaceable component failure has been detected. |
| SE+ dF + dash+ CF+ Px + blank- | A processor DIMM failure has been detected. |
| SE+ dF + dash+ CF+ Cx + blank- | A cache memory DIMM failure has been detected. |
| SE+ dF + dash+ CF+ dx + blank- | A processor or cache DIMM failure has been detected. |

| Displayed Diagnostic Code Sequences | Description |
|-------------------------------------|---|
| SE+ dF + dash+ CF+ Hx + blank- | A host card failure has been detected. |
| OE+ Lx + blank- | A lockdown condition has been detected. |
| OE+ L2+ dash+ CF+ Px + blank- | Persistent processor DIMM ECC errors have been detected, which result in a suspended controller state. |
| OE+ L2+ dash+ CF+ Cx + blank- | Persistent cache DIMM ECC errors have been detected, which result in a suspended controller state. |
| OE+ L2+ dash+ CF+ dx + blank- | Persistent processor or cache DIMM ECC errors have been detected, which result in a suspended controller state. |
| OE+ LC+ blank- | The write-protect switch is set during cache restore, which results in a suspended controller state. |
| OE+ LC+ dd + blank- | The memory size is changed from bad data in the flash drives, which results in a suspended controller state. |
| DE+ L2+ dash+ CF+ Cx + blank- | A cache memory diagnostic has been reported failed, which results in a suspended controller state. |

Things to Know – LEDs on the DE1600 Drive Tray and the DE5600 Drive Tray

LEDs on the Left End Cap

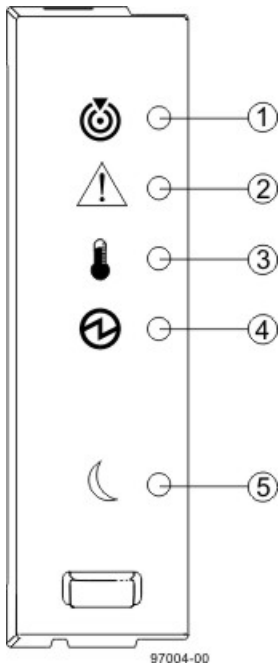

1. Drive Tray Locate LED
2. Drive Tray Service Action Required LED
3. Drive Tray Over-Temperature LED
4. Drive Tray Power LED
5. Drive Tray Standby Power LED

LEDs on the Left End Cap

| Location | LED | Color | On | Off |
|----------|------------------------------------|-------|--|--|
| 1 | Drive Tray Locate | White | Identifies a drive tray that you are trying to find. | Normal status. |
| 2 | Drive Tray Service Action Required | Amber | A component within the drive tray needs attention. | Normal status. |
| 3 | Drive Tray Over-Temperature | Amber | The temperature of the drive tray has reached an unsafe level. | Normal status. |
| 4 | Drive Tray Power | Green | Power is present. | Power is not present. |
| 5 | Drive Tray Standby Power | Green | The drive tray is in Standby Power mode. | The drive tray is not in Standby Power mode. |

LEDs on the Drive

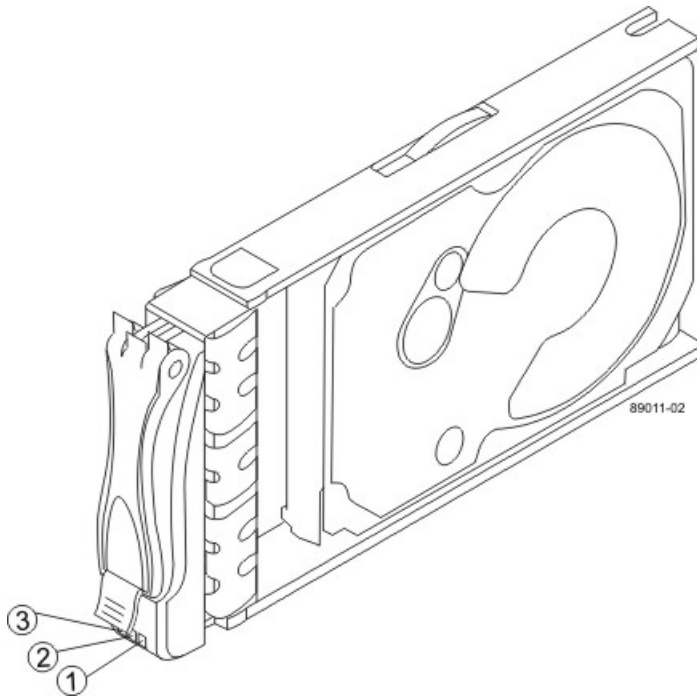

1. Drive Power LED
2. Drive Service Action Required LED
3. Drive Service Action Allowed LED

LEDs on the Drive

| Location | LED | Color | On | Blinking | Off |
|----------|-------------------------------|-------|---|-------------------------------------|--|
| 1 | Drive Power | Green | The power is turned on, and the drive is operating normally. | Drive I/O activity is taking place. | The power is turned off. |
| 2 | Drive Service Action Required | Amber | An error has occurred. | | Normal status. |
| 3 | Drive Service Action Allowed | Blue | The drive canister can be removed safely from the drive tray. | | The drive canister cannot be removed safely from the drive tray. |

Drive State Represented by LEDs

| Drive State | Drive Power LED (Green) | Drive Service Action Required LED (Amber) |
|-----------------------|-------------------------|---|
| Power is not applied. | Off | Off |

| Drive State | Drive Power LED (Green) | Drive Service Action Required LED (Amber) |
|---|-------------------------|---|
| Normal operation – The power is turned on, but drive I/O activity is not occurring. | On | Off |
| Normal operation – Drive I/O activity is occurring. | Blinking | Off |
| Service action required – A fault condition exists, and the drive is offline. | On | On |

LEDs on the ESM Canister

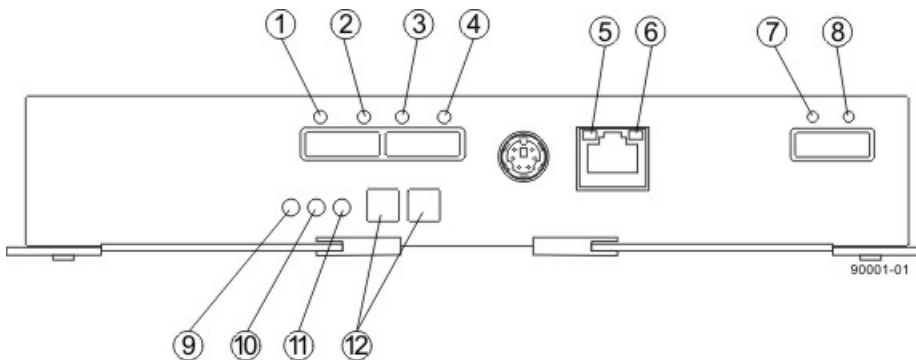

1. Host Link 1 Fault LED
2. Host Link 1 Active LED
3. Host Link 2 Fault LED
4. Host Link 2 Active LED
5. Ethernet Link Active LED
6. Ethernet Link Rate LED
7. ESM Expansion Link Fault LED
8. ESM Expansion Link Active LED
9. ESM Service Action Allowed LED
10. ESM Service Action Required LED
11. ESM Power LED
12. Seven-Segment Tray ID

LEDs on the ESM Canister

| Location | LED | Color | On | Off |
|----------|--------------------|-------|---|-----------------------------|
| 1 | Host Link 1 Fault | Amber | At least one PHY of the four connectors is working, but another PHY cannot establish the same link to the device connected to the Host IN port connector. | No link error has occurred. |
| 2 | Host Link 1 Active | Green | At least one of the four PHYs in the In port is working, and a link | A link error has occurred. |

| Location | LED | Color | On | Off |
|----------|-----------------------------|-------|---|---|
| | | | exists to the device connected to the Host In connector. | |
| 3 | Host Link 2 Fault | Amber | At least one PHY of the four connections is working, but another PHY cannot establish the same link to the device connected to the Host In port connector | No link error has occurred. |
| 4 | Host Link 2 Active | Green | At least one of the four PHYs in the IN port is working, and a link exists to the device connected to the Host In connector. | A link error has occurred. |
| 5 | Ethernet Link Active | Green | The link is up. (The LED blinks when there is activity.) | The link is not active. |
| 6 | Ethernet Link Rate | Green | There is a 100BASE-T rate. | There is a 10BASE-T rate. |
| 7 | ESM Expansion Link Fault | Amber | At least one of the four PHYs in the Out port is working, but another PHY cannot establish the same link to the Expansion Out connector. | Normal status. |
| 8 | ESM Expansion Link Active | Green | At least one of the four PHYs in the Out port is working, and a link exists to the device connected to the Expansion Out connector. | A link error has occurred. |
| 9 | ESM Service Action Allowed | Blue | The ESM can be removed safely from the drive tray. | The ESM cannot be removed safely from the drive tray. |
| 10 | ESM Service Action Required | Amber | A fault exists within the ESM. (This LED defaults on at power up. This LED turns off after the software has completed its power up self-test sequence.) | Normal status. |

| Location | LED | Color | On | Off |
|----------|-----------------------|-------|----------------------------------|----------------------------------|
| 11 | ESM Power | Green | 12V power to the ESM is present. | Power is not present to the ESM. |
| 12 | Seven-Segment Tray ID | Green | See note. | Not applicable. |

NOTE: For more information about the seven-segment tray IDs, see [Things to Know – Seven-Segment Display for the DE1600 Drive Tray and the DE5600 Drive Tray](#).

LEDs on the AC Power-Fan Canister

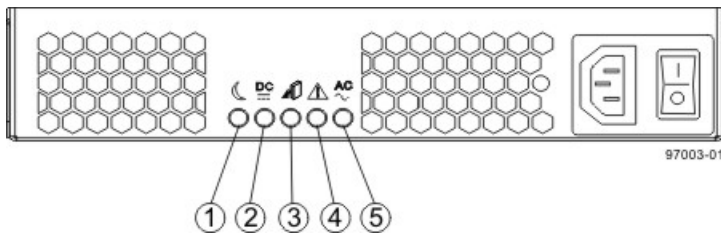

1. Standby Power LED
2. Power-Fan Output DC Power LED
3. Power-Fan Service Action Allowed LED
4. Power-Fan Service Action Required LED
5. Power-Fan Input AC Power LED

LEDs on the DC Power-Fan Canister

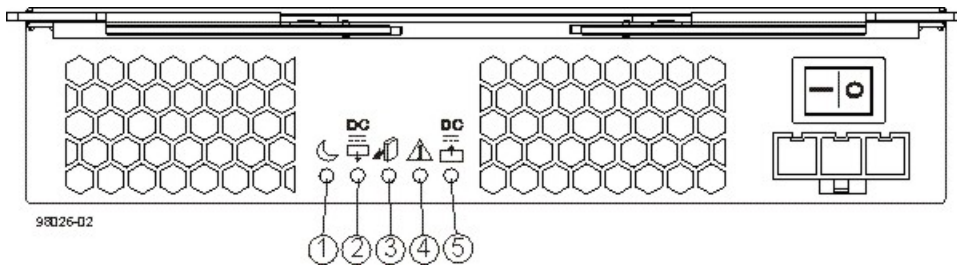

1. Standby Power LED
2. Power-Fan Output DC Power LED
3. Power-Fan Service Action Allowed LED
4. Power-Fan Service Action Required LED
5. Power-Fan Input DC Power LED

LEDs on the Power-Fan Canister

| Location | LED | Color | On | Off |
|----------|--------------------|-------|---|---|
| 1 | Standby Power | Green | The drive tray is in Standby mode, and DC power is not available. | The drive tray is not in Standby mode, and DC power is available. |
| 2 | Power-Fan DC Power | Green | DC power from the power-fan canister is available. | DC power from the power-fan canister is not available. |

| Location | LED | Color | On | Off |
|----------|-----------------------------------|-------|---|--|
| 3 | Power-Fan Service Action Allowed | Blue | The power-fan canister can be removed safely from the drive tray. | The power-fan canister cannot be removed safely from the drive tray. |
| 4 | Power-Fan Service Action Required | Amber | A fault exists within the power-fan canister. | Normal status. |
| 5 | Power-Fan AC Power | Green | AC power to the power-fan canister is present. | AC power to the power-fan canister is not present. |

Things to Know – LEDs on the DE6600 Drive Tray

LEDs on the Left End Cap

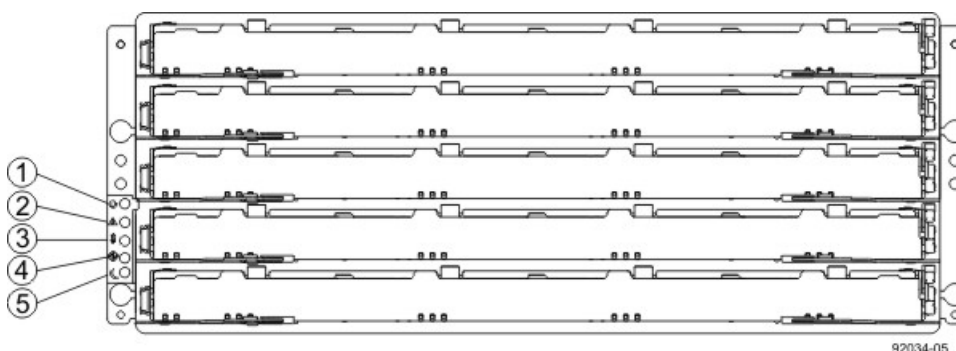

1. Drive Tray Locate LED
2. Drive Tray Service Action Required LED
3. Drive Tray Over-Temperature LED
4. Drive Tray Power LED
5. Drive Tray Standby Power LED

LEDs on the Left End Cap

| Location | LED | Color | On | Off |
|----------|------------------------------------|-------|--|-----------------------|
| 1 | Drive Tray Locate | White | Identifies a drive tray that you are trying to find. | Normal status. |
| 2 | Drive Tray Service Action Required | Amber | A component within the drive tray needs attention. | Normal status. |
| 3 | Drive Tray Over-Temperature | Amber | The temperature of the drive tray has reached an unsafe level. | Normal status. |
| 4 | Drive Tray Power | Green | Power is present. | Power is not present. |

| Location | LED | Color | On | Off |
|----------|--------------------------|-------|--|--|
| 5 | Drive Tray Standby Power | Green | The drive tray is in Standby Power mode. | The drive tray is not in Standby Power mode. |

LEDs on the ESM Canister

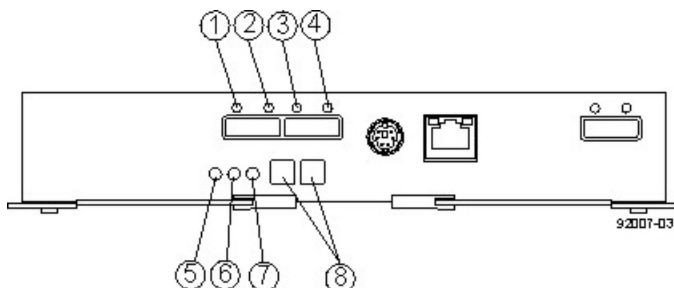

1. ESM Link Fault LED (Port 1A Bypass)
2. ESM Link LED (Port 1A Data Rate)
3. ESM Link LED (Port 1B Data Rate)
4. ESM Link Fault LED (Port 1B Bypass)
5. ESM Service Action Allowed LED
6. ESM Service Action Required LED
7. ESM Power LED
8. Seven-Segment Tray ID

LEDs on the ESM Canister

| Location | LED | Color | On | Off |
|----------|---------------------------------|-------|--|---|
| 1 | ESM Link Fault (Port 1A Bypass) | Amber | A link error has occurred. | No link error has occurred. |
| 2 | ESM Link (Port 1A) | Green | The link is up. | A link error has occurred. |
| 3 | ESM Link (Port 1B Bypass) | Green | The link is up. | A link error has occurred. |
| 4 | ESM Link Fault (Port 1B) | Amber | A link error has occurred. | No link error has occurred. |
| 5 | ESM Service Action Allowed | Blue | The ESM can be removed safely from the drive tray. | The ESM cannot be removed safely from the drive tray. |
| 6 | ESM Service Action Required | Amber | A fault exists within the ESM. | Normal status. |
| 7 | ESM Power | Green | Power to the ESM is present. | Power is not present to the ESM. |

| Location | LED | Color | On | Off |
|----------|-----------------------|-------|--|-----------------|
| 8 | Seven-Segment Tray ID | Green | For more information, see “Supported Diagnostic Codes on the Seven-Segment Display”. | Not applicable. |

LEDs on the Power Canister

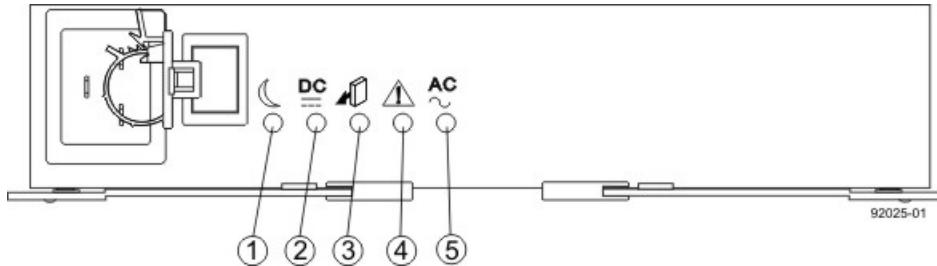

1. Power Standby Power LED
2. Power DC Power LED
3. Power Service Action Allowed LED
4. Power Service Action Required LED
5. Power AC Power LED

LEDs on the Power Canister

| Location | LED | Color | On | Off |
|----------|-------------------------------|-------|--|--|
| 1 | Power Standby Power | Green | The drive tray is in Standby mode and DC power is not available. | The drive tray is not in Standby mode and DC power is available. |
| 2 | Power DC Power | Green | DC power from the power canister is available. | DC power from the power canister is not available. |
| 3 | Power Service Action Allowed | Blue | The power canister can be removed safely from the drive tray. | The power canister cannot be removed safely from the drive tray. |
| 4 | Power Service Action Required | Amber | A fault exists within the power canister. | Normal status. |
| 5 | Power AC Power | Green | AC power to the power canister is present. | AC power to the power canister is not present. |

LEDs on the Fan Canister

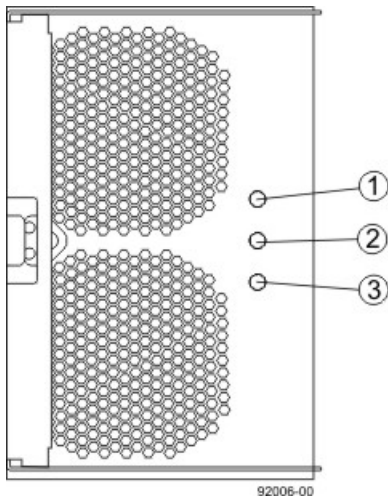

1. Fan Power LED
2. Fan Service Action Required LED
3. Fan Service Action Allowed LED

LEDs on the Fan Canister

| Location | LED | Color | On | Off |
|----------|-----------------------------|-------|---|--|
| 1 | Fan Power | Green | Power from the fan canister is available. | Power to the fan customer-replaceable unit (CRU) is available. |
| 2 | Fan Service Action Required | Amber | A fault exists within the fan canister. | Normal status. |
| 3 | Fan Service Action Allowed | Blue | The fan canister can be removed safely from the drive tray. | The fan canister cannot be removed safely from the drive tray. |

LEDs on the DE6600 Drive Tray Drawer

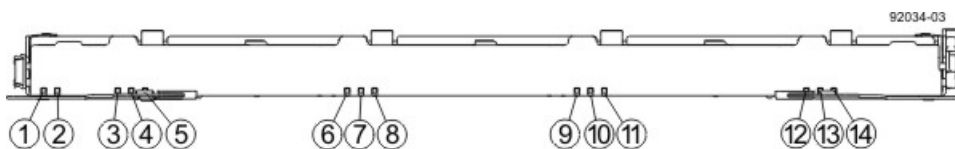

1. Drive Drawer Status Service Action Required LED
2. Drive Drawer Status Service Action Allowed LED
3. Drive 1 Activity LED
4. Drive 2 Activity LED
5. Drive 3 Activity LED
6. Drive 4 Activity LED
7. Drive 5 Activity LED
8. Drive 6 Activity LED
9. Drive 7 Activity LED
10. Drive 8 Activity LED
11. Drive 9 Activity LED
12. Drive 10 Activity LED
13. Drive 11 Activity LED
14. Drive 12 Activity LED

LEDs on the DE6600 Drive Tray Drawer

| Location | LED | Color | On | Blinking | Off |
|----------|--|-------|---|-------------------------------------|--|
| 1 | Drive Drawer Service Action Required | Amber | An error has occurred. | | Normal status. |
| 2 | Drive Drawer Service Action Allowed | Blue | The drive canister can be removed safely from the drive drawer in the drive tray. | | The drive canister cannot be removed safely from the drive drawer in the drive tray. |
| 3–14 | Drive Activity for drives 1 through 12 in the drive drawer | Green | The power is turned on, and the drive is operating normally. | Drive I/O activity is taking place. | The power is turned off. |

Drive State Represented by the LEDs

| Drive State | Drive Activity LED (Green) | Drive Service Action Required LED (Amber) |
|---|----------------------------|---|
| Power is not applied. | Off | Off |
| Normal operation – The power is turned on, but drive I/O activity is not occurring. | On | Off |
| Normal operation – Drive I/O activity is occurring. | Blinking | Off |

| Drive State | Drive Activity LED (Green) | Drive Service Action Required LED (Amber) |
|---|----------------------------|---|
| Service action required – A fault condition exists, and the drive is offline. | On | On |

LEDs on the DE6600 Drive Tray Drive



1. Drive Service Action Allowed LED
2. Drive Service Action Required LED

LEDs on the DE6600 Drive Tray Drives

| Location | LED | Color | On | Blinking | Off |
|----------|-------------------------------|-------|---|----------|--|
| 1 | Drive Service Action Allowed | Blue | The drive canister can be removed safely from the drive drawer in the drive tray. | | The drive canister cannot be removed safely from the drive drawer in the drive tray. |
| 2 | Drive Service Action Required | Amber | An error has occurred. | | Normal status. |







Drive State Represented by the LEDs



| Drive State | Drive Activity LED (Green) | Drive Service Action Required LED (Amber) |
|---|----------------------------|---|
| Power is not applied. | Off | Off |
| Normal operation – The power is turned on, but drive I/O activity is not occurring. | On | Off |
| Normal operation – Drive I/O activity is occurring. | Blinking | Off |

| Drive State | Drive Activity LED (Green) | Drive Service Action Required LED (Amber) |
|---|----------------------------|---|
| Service action required – A fault condition exists, and the drive is offline. | On | On |

Things to Know – General Behavior of the LEDs on the DE1600 Drive Tray, the DE5600 Drive Tray, and the DE6600 Drive Tray

LED Symbols and General Behavior

| LED | Symbol | Location | General Behavior |
|---------------------------------|---|--|---|
| Power |  | Drive tray (front bezel) ESM canister Power-fan canister | On – Power is applied to the drive tray or the canister. Off – Power is not applied to the drive tray or the canister. |
| Drive Tray Locate |  | Front bezel on the drive tray | On or blinking – Indicates the drive tray that you are trying to find. |
| Drive Tray Over-Temperature |  | Front bezel on the drive tray | On – The temperature of the drive tray has reached an unsafe condition. Off – The temperature of the drive tray is within operational range. |
| Standby Power |  | Front bezel on the drive tray | On – The drive tray is in Standby mode, and the main power is off. Off – The drive tray is not in Standby mode, and the main power is on. |
| Service Action Allowed |  | ESM canister Power-fan canister Drive | On – It is safe to remove the ESM canister, the power-fan canister, or the drive. Off – Do not remove the ESM canister, the power-fan canister, or the drive. The drive has an LED but no symbol. |
| Service Action Required (Fault) |  | ESM canister Power-fan canister Drive | On – When the drive tray LED is on, a component within the drive tray needs attention. On – The ESM canister, the power-fan canister, or the drive needs attention. |

| LED | Symbol | Location | General Behavior |
|--|---|---------------------------------------|--|
| | | | Off – The ESM canister, the power-fan canister, and the drive are operating normally. The drive has an LED but no symbol. |
| AC Power | AC  | ESM canister Power-fan canister | On – AC power is present. Off – AC power is not present. |
| DC Power (DE1600 and DE5600 only) | DC  | Power-fan canister | On – Regulated DC power from the power canister and the fan canister is present. Off – Regulated DC power from the power-fan canister is not present. |
| Link Service Action Required (Fault) |  | ESM canister | On – The cable is attached and at least one lane has a link-up status, but one lane has a link-down status. Off – The cable is not attached, the cable is attached and all lanes have a link-up status, or the cable is attached and all lanes have a link-down status. |
| Link Up | Two LEDs above each expansion connector | ESM canister | On – The cable is attached and at least one lane has a link-up status. Off – The cable is not attached, or the cable is attached and all lanes have a link-down status. |

Things to Know – Seven-Segment Display for the DE1600 Drive Tray and the DE5600 Drive Tray

During normal operation, the tray ID display on each ESM displays the drive tray ID. The Diagnostic LED (lower-digit decimal point) comes on when the display is used for diagnostic codes and goes off when the display is used to show the tray ID.

 **NOTE** If a power-on or reset occurs, the Diagnostic LED, the Heartbeat LED (upper-digit decimal point), and all seven segments of both digits come on. The Diagnostic LED remains on until the drive tray ID appears.

Supported Diagnostic Codes

| Diagnostic Code | ESM State | Description |
|-----------------|-----------|--|
| .8, 8., or 88 | Suspended | This ESM is being held in reset by another ESM. |
| L0 | Suspended | The ESM types are mismatched. |
| L2 | Suspended | A persistent memory error has occurred. |
| L3 | Suspended | A persistent hardware error has occurred. |
| L9 | Suspended | An over-temperature condition has been detected in either the ESM or the power supply. |
| LL | Suspended | The midplane SBB VPD EEPROM cannot be accessed. |
| Ln | Suspended | The ESM canister is not valid for this drive tray. |
| LP | Suspended | Drive port mapping tables are not found. |
| H0 | Suspended | An ESM Fibre Channel interface failure has occurred. |
| H1 | Suspended | An SFP transceiver speed mismatch (a 2-Gb/s SFP transceiver is installed when the drive tray is operating at 4 Gb/s) indicates that an SFP transceiver must be replaced. Look for the SFP transceiver with a blinking amber LED. |
| H2 | Suspended | The ESM configuration is invalid or incomplete, and it operates in a Degraded state. |
| H3 | Suspended | The maximum number of ESM reboot attempts has been exceeded. |
| H4 | Suspended | This ESM cannot communicate with the alternate ESM. |
| H5 | Suspended | A midplane harness failure has been detected in the drive tray. |
| H6 | Suspended | An ESM firmware failure has been detected. |
| H8 | | SFP transceivers are present in currently unsupported ESM slots, either 2A or 2B. Secondary trunking SFP transceiver slots 2A and 2B are not supported. Look for the SFP transceiver with the blinking amber LED, and remove it. |
| H9 | | A non-catastrophic hardware failure has occurred. The ESM is operating in a Degraded state. |
| J0 | Suspended | The ESM canister is incompatible with the drive tray firmware. |

CE7900 Controller Tray Installation

This topic provides basic information for installing the CE7900 controller tray and the corresponding drive trays (the FC4600 drive tray and the DE6900 drive tray) in a storage array. After you have completed these tasks, you will continue onto the *Initial Configuration and Software Installation* electronic document topics or the PDF on the SANtricity ES Storage Manager Installation DVD.

Step 1 – Preparing for a CE7900 Controller Tray Installation

The CE7900 storage array consists of a CE7900 controller tray and one or more drive trays in a cabinet. Use this initial setup guide to install the CE7900 controller tray. This document includes instructions for installing the DE6900 drive trays or FC4600 drive trays.

Key Terms

storage array

A collection of both physical components and logical components for storing data. Physical components include drives, controllers, fans, and power supplies. Logical components include volume groups and volumes. These components are managed by the storage management software.

controller tray

One tray with one or two controllers. The controller tray also contains power supplies, fans, and other supporting components. The controller tray provides the interface between a host and a storage array. A controller tray does not have drives for storing data.

controller

A circuit board and firmware that is located within a controller tray or a controller-drive tray. A controller manages the input/output (I/O) between the host system and data volumes.

drive tray

One tray with drives, one or two environmental services monitors (ESMs), power supplies, and fans. A drive tray does not contain controllers.

environmental services monitor (ESM)

A canister in the drive tray that monitors the status of the components. An ESM also serves as the connection point to transfer data between the drive tray and the controller.

Small Form-factor Pluggable (SFP) transceiver

A component that enables Fibre Channel duplex communication between storage array devices. SFP transceivers can be inserted into host bus adapters (HBAs), controllers, and environmental services monitors (ESMs). SFP transceivers can support either copper cables (the SFP transceiver is integrated with the cable) or fiber-optic cables (the SFP transceiver is a separate component from the fiber-optic cable).



Gathering Items

Before you start installing the controller tray, you must have installed the cabinet in which the controller tray will be mounted.

Use the tables in this section to verify that you have all of the necessary items to install the controller tray.

Basic Hardware for CE7900 Configurations

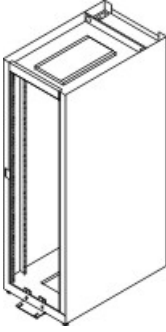
Basic Hardware

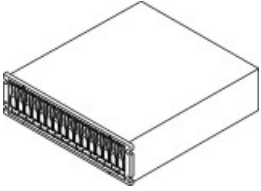
| | Item | Included with the Controller Tray |
|---|---|-----------------------------------|
|  | <p>Cabinet</p> <ul style="list-style-type: none"> Make sure that your cabinet meets the installation site specifications of the various CE7900 storage array components. Refer to the <i>Storage System Site Preparation Guide</i> on the SANtricity ES Storage Manager Installation DVD for more information. Depending on the power supply limitations of your cabinet, you might need to install more than one cabinet to accommodate the different components of the CE7900 storage array. Refer to the installation guide for your cabinet for instructions on installing the cabinet. | |
|  | <p>Mounting rails and screws</p> | |
|  | <p>DE6900 drive tray (shown with the separately packaged mounting rails attached).</p> | |
|  | <p>FC4600 drive tray with end caps that are packaged separately.</p> | |
| | <p>Fibre Channel switch (optional)</p> | |
| | <p>Host with Fibre Channel host bus adapters (HBAs)</p> | |

Cables and Connectors for a CE7900 Controller Tray Configuration

Cables and Connectors

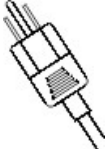
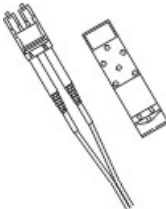
| | Item | Included with the Controller Tray |
|--|---|-----------------------------------|
|  | <p>AC power cords</p> <p>The controller-drive tray and the drive trays ship with power cords for connecting to an external power source, such as a wall plug. Your cabinet might have special power cords that you use instead of the power cords that ship with the controller-drive tray and the drive trays.</p> | ✓ |
| | <p>Use fiber-optic cables for Fibre Channel connections to the drive trays.</p> <p>For the differences between the fiber-optic cables and the copper Fibre Channel (FC) cables, see “Things to Know – SFP Transceivers, Fiber-Optic Cables, and Copper Cables”.</p> | |
|  | <p>Small Form-factor Pluggable (SFP) transceivers</p> <ul style="list-style-type: none"> ▪ The SFP transceivers connect fiber-optic cables to host ports and drive ports. ▪ Four or eight SFP transceivers are included with the controller tray; one for each of the host channel ports on the controllers. ▪ Depending on your connection requirements, you might need to purchase additional SFP transceivers (two SFP transceivers for each fiber-optic cable). ▪ Depending on the configuration of your storage array, you might need to use three different types of SFP transceivers: 10-Gb/s iSCSI, 8-Gb/s Fibre Channel, and 4-Gb/s Fibre Channel. ▪ You must purchase <i>only</i> Restriction of Hazardous Substances (RoHS)-compliant SFP transceivers. | ✓ |
| | <p>Copper Fibre Channel cables (optional)</p> <p>Use these cables for connections within the storage array.</p> <p>For the differences between the fiber-optic cables and the copper Fibre Channel cables, see the “Deciding on the Management Method” topic in either the <i>Initial Configuration and Software Installation</i> electronic topics or the PDF on the SANtricity ES Storage Manager Installation DVD.</p> | |
| | Fiber-optic InfiniBand cables | |

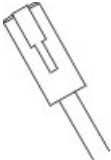
| | Item | Included with the Controller Tray |
|---|---|-----------------------------------|
| | Use these cables (or copper InfiniBand cables) with InfiniBand switches for InfiniBand connections between a controller tray and the hosts. | |
|  | <p>Ethernet cable</p> <p>This cable is used for out-of-band storage array management and for 1-Gb/s iSCSI connections. For information about out-of-band storage array management, see the "Deciding on the Management Method" topic in either the <i>Initial Configuration and Software Installation</i> electronic topics or the PDF on the SANtricity ES Storage Manager Installation DVD.</p> | |

Product DVDs



Product DVDs

| | Item | Included with the Controller Tray |
|---|---|-----------------------------------|
|  | <p>Firmware DVD</p> <ul style="list-style-type: none"> ▪ Firmware is already installed on the controllers. ▪ The files on the DVD are backup copies. <p>SANtricity ES Storage Manager Installation DVD</p> <ul style="list-style-type: none"> ▪ SANtricity ES Storage Manager software and documentation. ▪ To access product documentation, use the documentation map file, <code>doc_launcher.html</code>, which is located in the <code>docs</code> directory. | ✓ |

Tools and Other Items

Tools and Other Items

| | Item | Included with the Tray |
|--|--|------------------------|
| | <p>Labels</p> <p>Help you to identify cable connections and lets you more easily trace cables from one tray to another</p> | |
| | <p>A cart</p> <p>Holds the tray and components</p> | |

| | Item | Included with the Tray |
|--|------------------------------|------------------------|
| | A mechanical lift (optional) | |
|  | A Phillips screwdriver | |
|  | A flat-blade screwdriver | |
|  | Anti-static protection | |
| | A flashlight | |
| <p>Use the Compatibility Matrix, at the following website, to obtain the latest hardware compatibility information. http://www.lsi.com/compatibilitymatrix/</p> | | |

Things to Know – SFP Transceivers, Fiber-Optic Cables, and Copper Cables

The following figures show two types of cables and SFP transceivers for Fibre Channel connections. Your SFP transceivers and cables might look slightly different from the ones shown. The differences do not affect the performance of the SFP transceivers. Host connections that use 8-Gb/s Fibre Channel connections require a different type of SFP transceiver from that required by either 4-Gb/s Fibre Channel connections or 10-Gb/s iSCSI connections.



WARNING (W03) Risk of exposure to laser radiation – Do not disassemble or remove any part of a Small Form-factor Pluggable (SFP) transceiver because you might be exposed to laser radiation.

Fiber-Optic Cable Connection

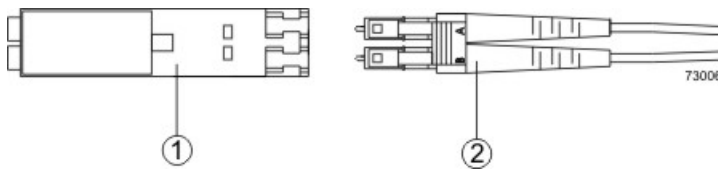

1. Active SFP Transceiver
2. Fiber-Optic Cable

Copper Fibre Channel Cable Connection

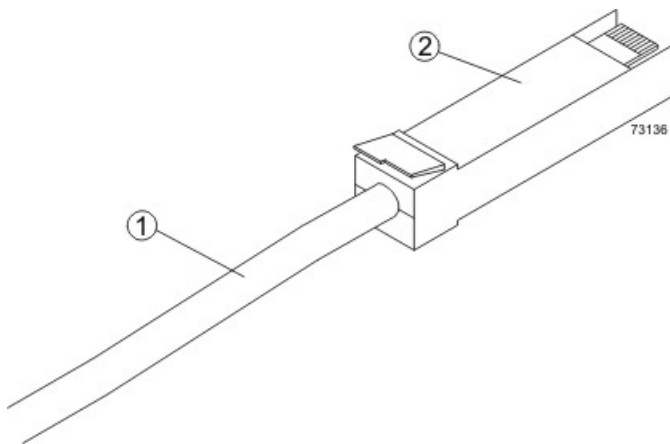

1. Copper Fibre Channel Cable
2. Passive SFP Transceiver

Host connections with iSCSI require a copper cable with RJ-45 connectors as shown in the following figure. Connections using iSCSI do not require SFP transceivers.

iSCSI Cable with an RJ-45 Connector

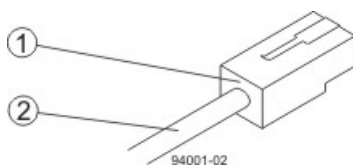

1. RJ-45 Connector
2. iSCSI Cable

Host connections with InfiniBand require a fiber-optic cable with InfiniBand connectors as shown in the following figure. Connections using InfiniBand do not require SFP transceivers.

InfiniBand Cable with Built-In Connectors

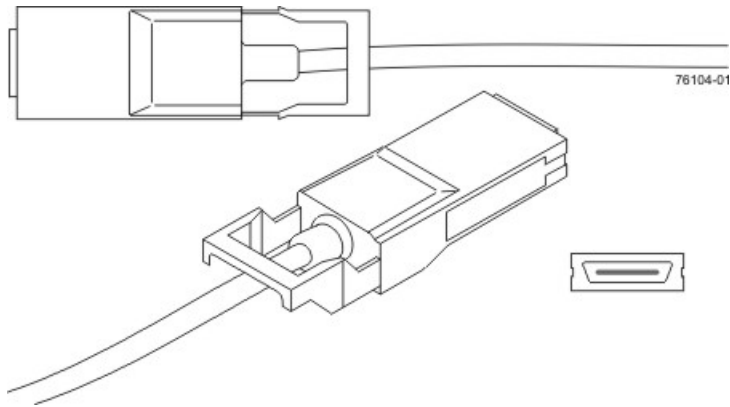

Things to Know – Taking a Quick Glance at the CE7900 Configuration Hardware

Characteristics of the CE7900 Controller Tray

- The top controller, controller A, is inverted from the bottom controller, controller B.
- The top of the controller tray is the side with labels.

CE7900 Controller Tray – Front View and Rear View

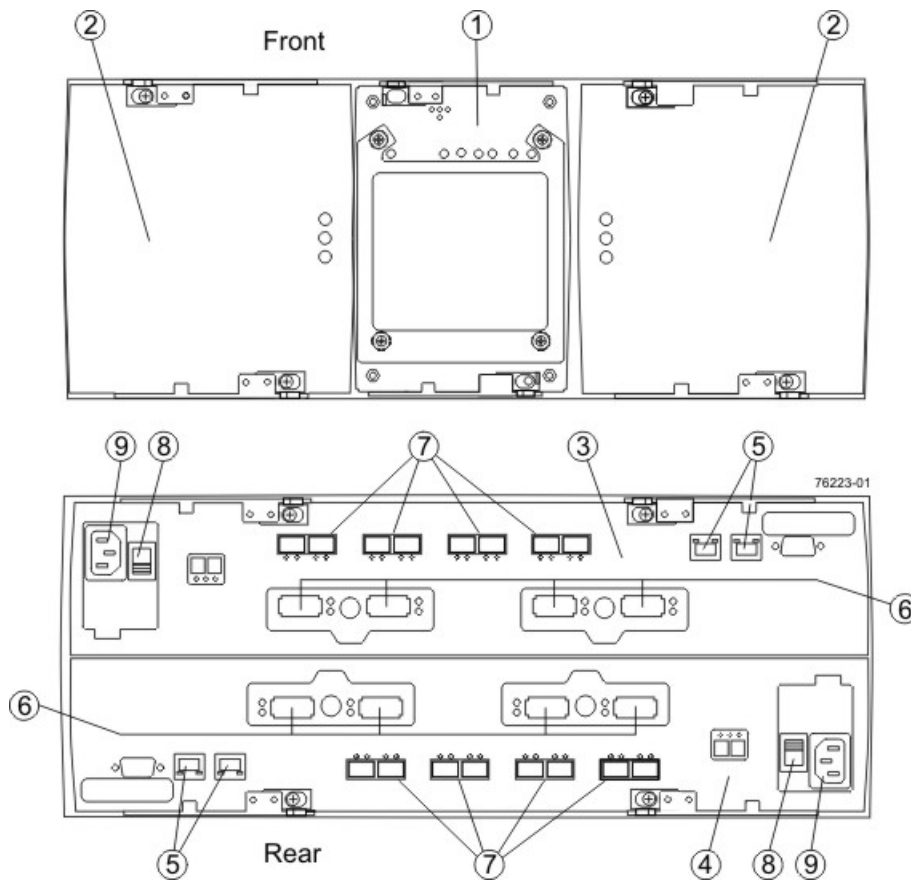

1. (Front View) Interconnect-Battery Canister
2. Power-Fan Canisters
3. (Rear View) Controller A (Inverted)
4. Controller B
5. Ethernet Ports
6. Host Channels
7. Dual-Ported Drive Channels
8. AC Power Switch
9. AC Input

⚠ ATTENTION Risk of equipment malfunction – To avoid exceeding the functional and environmental limits, install only drives that have been provided or approved by the original manufacturer. Drives might be shipped but not installed. System integrators, resellers, system administrators, or users can install the drives.

📌 NOTE You must use the current drive canisters in the drive tray to ensure proper performance. Using older or “legacy” drives might damage the connectors. Additionally, the latch might not hold the drive in place, which causes the drive to be disconnected and taken offline. For more information on supported drives, contact a Customer and Technical Support representative.

Characteristics of the DE6900 Controller Tray

The DE6900 drive tray consists of five drawers that can contain up to 60 SATA drives in a Fibre Channel host connection to a CE7900 controller tray.

IMPORTANT The installation order within each drawer is from left to right in rows. Slots 1, 4, 7, and 10 must have a drive installed in these locations to make sure there is sufficient air flow to the drives.

DE6900 Drive Tray – Front View with the Bezel

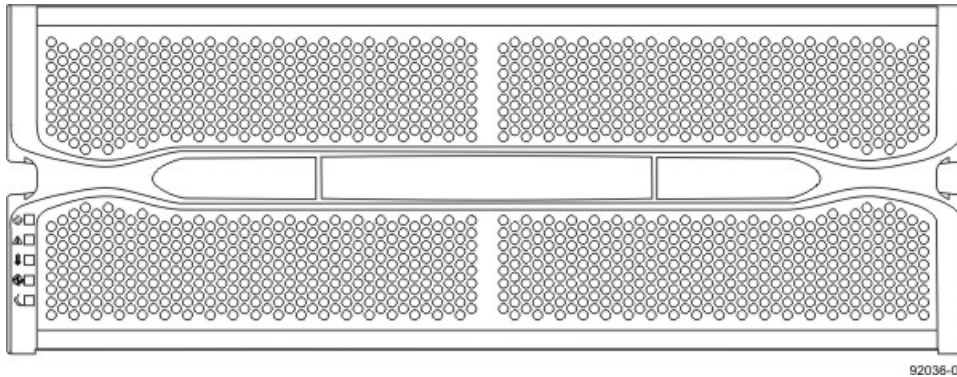

DE6900 Drive Tray – Front View with the Bezel Removed

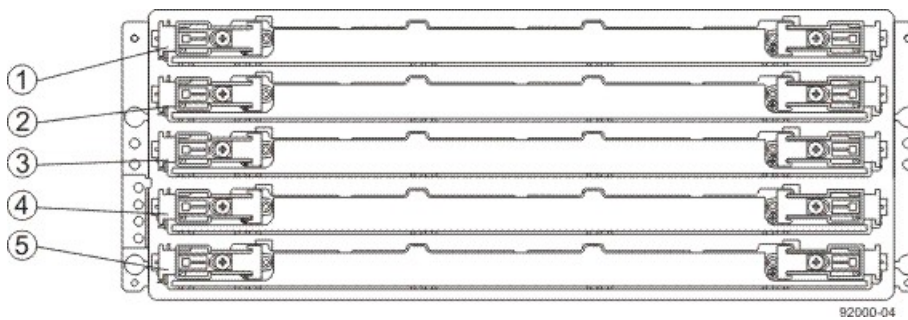

1. Drive Drawer 1
2. Drive Drawer 2
3. Drive Drawer 3
4. Drive Drawer 4
5. Drive Drawer 5

DE6900 Drive Tray – Rear View

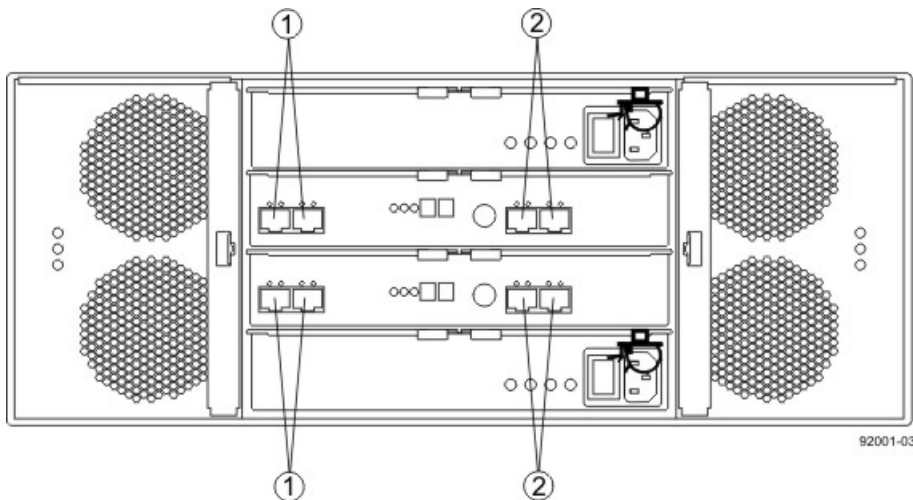

1. Standard Expansion Connectors
2. Drive-Side Trunking Expansion Connectors

Characteristics of the FC4600 Drive Tray

- The top-left ESM is inverted from the bottom-right ESM.
- The top-right power-fan canister is inverted from the bottom-left power-fan canister.
- The drive tray is in the correct (top) orientation when the lights of the drives are at the bottom (Figure

NOTE The FC4600 drive tray is available in rackmount models and desktside models. The components for the desktside model are identical to the components of the rackmount model. The desktside model is situated as if the rackmount model is sitting on its left side.

IMPORTANT Each FC4600 drive tray in the storage array must have a minimum of two drives for proper operation. If the tray has fewer than two drives, a power supply error is reported.

FC4600 Drive Tray – Front View

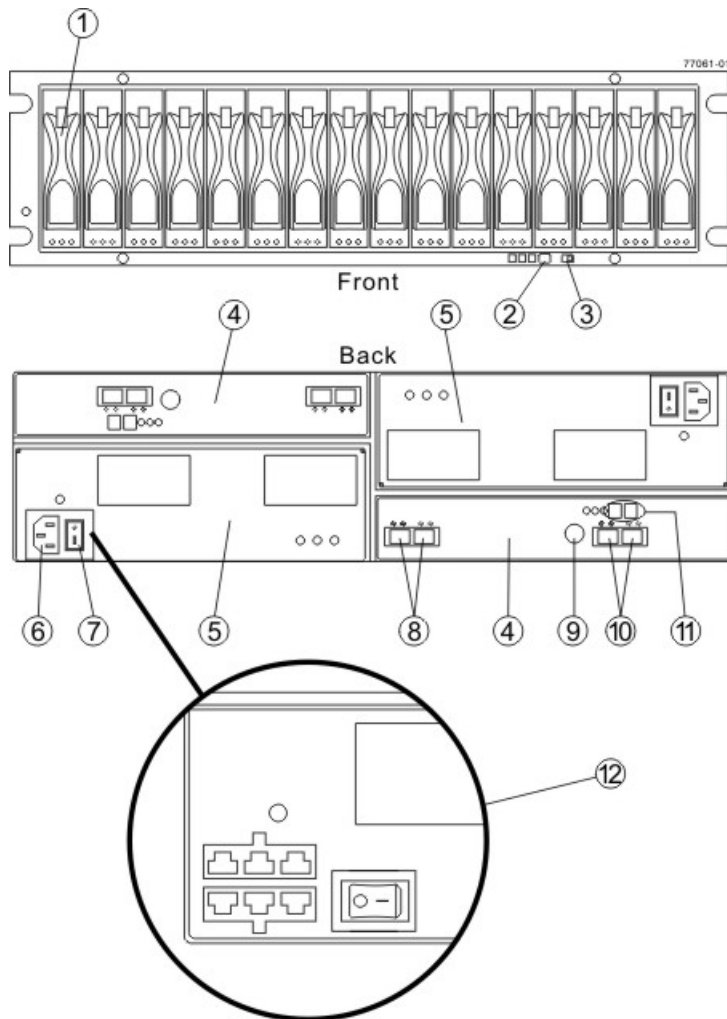

1. Drive Canister
2. Alarm Mute Button
3. Link (Data) Rate Switch (4 Gb/s or 2 Gb/s)
4. ESM Canister
5. Power-Fan Canister
6. AC Power Connector
7. AC Power Switch
8. In/Out Ports
9. Serial Port
10. In/Out Ports (Reserved for future use)
11. Tray ID / Seven-Segment Diagnostic Display
12. (Optional) DC Power Connectors and DC Power Switch



NOTE The DC Power Option is not available within the CE7900 Controller Tray Configuration.

For Additional Information on the CE7900 Controller-Drive Tray Configuration

Refer to the *Storage System Site Preparation Guide* on the SANtricity ES Storage Manager Installation DVD for information about the installation requirements of the various CE7900 storage array components.

Step 2 – Installing and Configuring the Switches

Things to Know – Switches



IMPORTANT Most of the switches, as shipped from the vendor, require an update to their firmware to work correctly with the storage array.

Depending on the configuration of your storage array, you might use Fibre Channel switches and iSCSI switches.

The switches in the following table are certified for use with a CDE2600 storage array, a CDE2600-60 storage array, a CDE4900 storage array, and a CE7900 storage array, which all use SANtricity ES Storage Manager Version 10.77.

Supported Switches

| Vendor | Model | Fibre Channel | iSCSI | SAS |
|---------|-------|---------------|-------|-----|
| Brocade | 200E | Yes | No | No |
| | 3200 | Yes | No | No |
| | 3800 | Yes | No | No |
| | 3900 | Yes | No | No |
| | 3950 | Yes | No | No |
| | 12000 | Yes | No | No |
| | 3850 | Yes | No | No |
| | 3250 | Yes | No | No |
| | 24000 | Yes | No | No |
| | 4100 | Yes | No | No |
| | 48000 | Yes | No | No |
| | 5000 | Yes | No | No |
| | 300 | Yes | No | No |
| | 5100 | Yes | No | No |
| | 5300 | Yes | No | No |
| | 7500 | Yes | No | No |
| | 7800 | Yes | No | No |
| DCX | Yes | No | No | |

| Vendor | Model | Fibre Channel | iSCSI | SAS |
|--------|---------------------|---------------|-------|-----|
| | FCOE | No | Yes | No |
| Cisco | 9506 | Yes | No | No |
| | 9509 | Yes | No | No |
| | 9216 | Yes | No | No |
| | 9216i | Yes | No | No |
| | 9120 | Yes | No | No |
| | 914x | Yes | No | No |
| | 9513 | Yes | No | No |
| | 9020 | Yes | No | No |
| | MDS9000 | Yes | No | No |
| | 9222i | Yes | No | No |
| | 9134 | Yes | No | No |
| | Catalyst 2960 | No | Yes | No |
| | Catalyst 3560 | No | Yes | No |
| | Catalyst 3750G-24TS | No | Yes | No |
| LSI | 6160 | No | No | Yes |
| McData | 3232 | Yes | No | No |
| | 3216 | Yes | No | No |
| | 4300 | Yes | No | No |
| | 4500 | Yes | No | No |
| | 6064 | Yes | No | No |
| | 6140 | Yes | No | No |
| | 4400 | Yes | No | No |
| | 4700 | Yes | No | No |
| QLogic | 6140 | No | Yes | No |
| | 6142 | No | Yes | No |
| | SANbox2-8 | Yes | No | No |

| Vendor | Model | Fibre Channel | iSCSI | SAS |
|--------------|------------|---------------|-------|-----|
| | SANbox2-16 | Yes | No | No |
| | SANbox5200 | Yes | No | No |
| | SANbox3600 | Yes | No | No |
| | SANbox3800 | Yes | No | No |
| | SANbox5208 | Yes | No | No |
| | SANbox5600 | Yes | No | No |
| | SANbox5800 | Yes | No | No |
| | SANbox9000 | Yes | No | No |
| PowerConnect | 5324 | No | Yes | No |
| | 6024 | No | Yes | No |

If required, make the appropriate configuration changes for *each* switch that is connected to the storage array.

Refer to the switch's documentation for information about how to install the switch and how to use the configuration utilities that are supplied with the switch.

Procedure – Installing and Configuring Switches

1. Install your switch according to the vendor's documentation.
2. Use the Compatibility Matrix at the website <http://www.lsi.com/compatibilitymatrix/> to obtain this information:
 - The latest hardware compatibility information
 - The models of the switches that are supported
 - The firmware requirements and the software requirements for the switches
3. Update the switch's firmware by accessing it from the applicable switch vendor's website.

This update might require that you cycle power to the switch.

4. Find your switch in the following table to see whether you need to make further configuration changes. Use your switch's configuration utility to make the changes.

Supported Switch Vendors and Required Configuration Changes

| Switch Vendor | Configuration Changes Required? | Next Step |
|---------------|---|--|
| Brocade | Yes Change the In-Order Delivery (IOD) option to ON. | Make the change, and go to “.Step 3 – Installing the Host Bus Adapters for the CE7900 Controller Tray” |

| Switch Vendor | Configuration Changes Required? | Next Step |
|---------------|---|--|
| Cisco | Yes Change the In-Order Delivery (IOD) option to ON. | Make the change, and go to “Step 3 – Installing the Host Bus Adapters for the CE7900 Controller Tray.” |
| McData | No | “Step 3 – Installing the Host Bus Adapters for the CE7900 Controller Tray.” |
| QLogic | No | “Step 3 – Installing the Host Bus Adapters for the CE7900 Controller Tray.” |
| PowerConnect | No | “Step 3 – Installing the Host Bus Adapters for the CE7900 Controller Tray.” |

Step 3 – Installing the Host Bus Adapters for the CE7900 Controller Tray

Key Terms

HBA host port

The physical and electrical interface on the host bus adapter (HBA) that provides for the connection between the host and the controller. Most HBAs will have either one or two host ports. The HBA has a unique World Wide Identifier (WWID) and each HBA host port has a unique WWID.

HBA host port world wide name

A 16-character unique name that is provided for each port on the host bus adapter (HBA).

host bus adapter (HBA)

A physical board that resides in the host. The HBA provides for data transfer between the host and the controllers in the storage array over the I/O host interface. Each HBA contains one or more physical ports.

Things to Know – Host Adapters

Host connections might be Fibre Channel connections through host bus adapters (HBAs), InfiniBand connections through host channel adapters (HCAs), or iSCSI connections through Ethernet adapters. The CE7900 controller tray can have host interface cards (HICs) for any of these types of connections. The type of a host adapter installed in a host must match the type of the HIC to which it connects. When host connections are made through switches, the switches must support the speed and protocol of the connection.

- For maximum hardware redundancy, you must install a minimum of two host adapters in each host. Dual-ported host adapters provide two paths into the storage array but do not ensure redundancy if the entire host adapter fails.
- Most of the host adapters, as shipped from the vendor, require updated firmware and software drivers to work correctly with the storage array. For information about the updates, refer to the web site of the vendor for the host adapter.



NOTE You can use the Compatibility Matrix to obtain information about the supported models of the host adapters and their requirements. Go to the web page at <http://www.lsi.com/CompatibilityMatrix/>. In the search form, choose **Host Adapter** from the **Product** drop-down list. Use the search form to make sure you have an acceptable configuration.

- For best performance, cable an 8-Gb/s Fibre Channel HIC to an 8-Gb/s HBA. If the data rate for the HBA is lower, the data transfer will occur at the lower rate. For instance, if you cable an 8-Gb/s Fibre Channel HIC to a 4-Gb/s HBA, the data transfer rate is 4 Gb/s.
- You cannot mix InfiniBand connections with other types of connections.

It is possible for a host to have both iSCSI (Ethernet) and Fibre Channel (HBA) adapters for connections to a storage array that has a mix of HICs. Several restrictions apply to such configurations.

- The root boot feature is not supported for hosts with mixed connections to one storage array.
- Cluster configurations are supported for hosts with mixed connections to one storage array.
- When the host operating system is VMware, mixing of connection types within a partition is not supported.

- When the host operating system is Windows, mixing of connection types within a storage partition is not supported. A single server that attaches to multiple storage partitions on a single array must not have any overlap in LUN number assignments given to the volumes.
- For other operating systems, mixed connection types from a host to a single storage array are not supported.

Procedure – Installing Host Bus Adapters

1. Go to <http://www.lsi.com/compatibilitymatrix/>, and select the desired Developer Partner Program link. Check its Compatibility Matrix to make sure you have an acceptable configuration.

The Compatibility Matrix provides this information:

- The latest hardware compatibility information
- The models of the HBAs that are supported
- The firmware requirements and the software requirements for the HBAs

2. Install your HBA according to the vendor documentation.

 **NOTE** If your operating system is Windows Server 2008 Server Core, you might have additional installation requirements. Refer to the Microsoft Developers Network (MSDN) for more information about Windows Server 2008 Server Core. You can access these resources from www.microsoft.com.

3. Install the latest version of the firmware for the HBA. You can find the latest version of the firmware for the HBA at the HBA vendor website.

 **NOTE** The remaining steps are general steps to obtain the HBA host port world wide name from the HBA BIOS utility. If you have installed the host context agent on all of your hosts, you do not need to perform these steps. If you are performing these steps, the actual prompts and screens vary depending on the vendor that provides the HBA. Also, some HBAs have software utilities that you can use to obtain the world wide name for the port instead of using the BIOS utility.

4. Reboot or start your host.
5. While your host is booting, look for the prompt to access the HBA BIOS utility.
6. Select each HBA to view its HBA host port world wide name.
7. Record the following information for each host and for each HBA connected to the storage array:
 - The name of each host
 - The HBAs in each host
 - The HBA host port world wide name of each port on the HBA

The following table shows examples of the host and HBA information that you must record.

Examples of HBA Host Port World Wide Names

| Host Name | Associated HBAs | HBA Host Port World Wide Name |
|----------------|-------------------------------|--|
| ICTENGINEERING | Vendor x, Model y (dual port) | 37:38:39:30:31:32:33:32 37:38:39:30:31:32:33:33 |
| | Vendor a, Model y (dual port) | 42:38:39:30:31:32:33:42 42:38:39:30:31:32:33:44 |

| Host Name | Associated HBAs | HBA Host Port World Wide Name |
|------------|---------------------------------|-------------------------------|
| ICTFINANCE | Vendor a, Model b (single port) | 57:38:39:30:31:32:33:52 |
| | Vendor x, Model b (single port) | 57:38:39:30:31:32:33:53 |

Step 4 – Installing the Controller Tray

Things to Know – General Installation

The power supplies meet standard voltage requirements for both domestic and worldwide operation.



IMPORTANT Make sure that the combined power requirements of your trays do not exceed the power capacity of your cabinet.

Steps to Install – CE7900 Controller Tray

1. Make sure that the cabinet is in the final location. Make sure that the cabinet installation site meets the clearance requirements.

Airflow Direction Through and Clearance Requirements for the Controller Tray

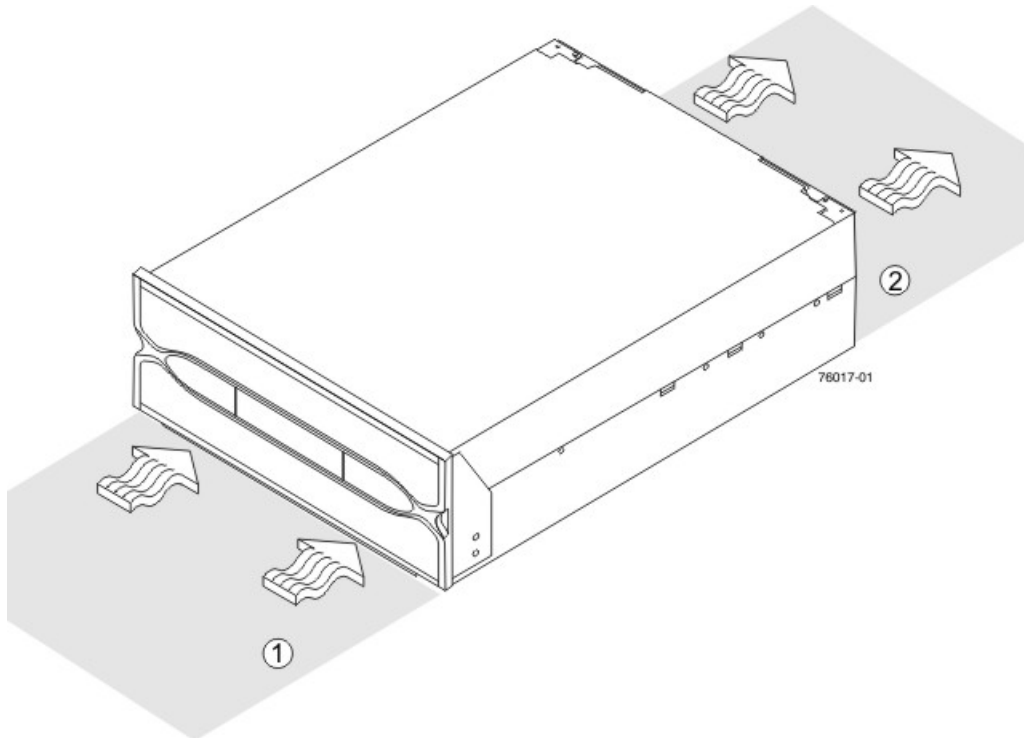

1. 76-cm (30-in.) clearance in front of the cabinet
 2. 61-cm (24-in.) clearance behind the cabinet
2. Lower the feet on the cabinet, if required, to keep it from moving.
 3. Install the mounting rails in the cabinet. For more information, refer to the installation instructions that are included with your mounting rails.
 - If you are installing the mounting rails above an existing tray, position the mounting rails directly above the tray.
 - If you are installing the mounting rails below an existing tray, allow 17.8-cm (7.00-in.) clearance below the existing tray.

 **NOTE** If you are installing only FC4600 drive trays, make sure that you place the controller tray in the middle portion of the cabinet while allowing room for drive trays to be placed above and below the controller tray. As you add drive trays, position them below and above the controller tray, starting below and alternating so that the cabinet does not become top heavy.

 **NOTE** If you are installing DE6900 drive trays, make sure that you place the controller tray so that you can install all of the DE6900 drive trays below it. Install DE6900 drive trays starting from the bottom of the cabinet.

 **WARNING (W09) Risk of bodily injury –**



>35 kg (70.5 lbs)

Three persons are required to safely lift the component.

4. With the help of two other persons, slide the rear of the controller tray onto the mounting rails, and make sure that the top mounting holes on the controller tray align with the mounting rail holes of the cabinet.

The rear of the controller tray slides into the slots on the mounting rails.

 **NOTE** The rear of the controller tray contains two controllers. The top of the controller tray is the side with the labels.

Securing the Controller Tray to the Cabinet

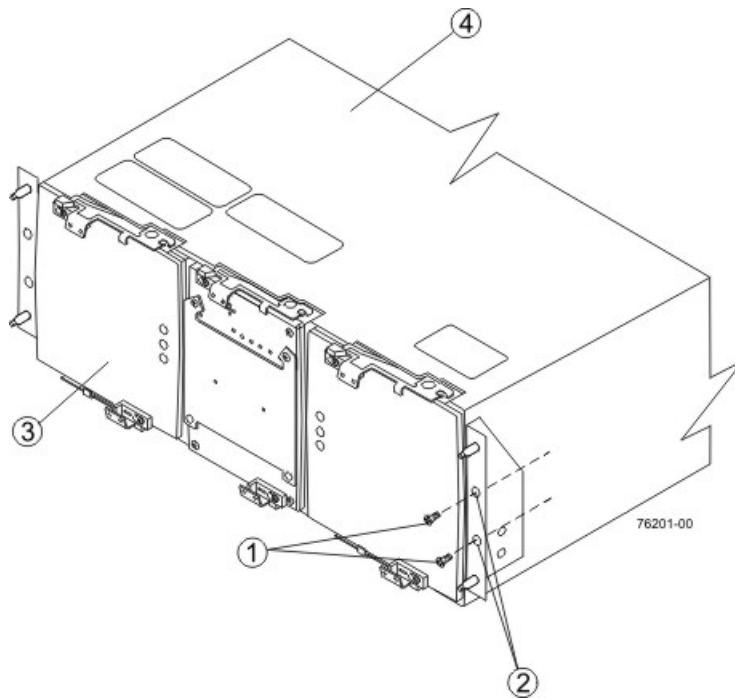

1. Screws
2. Mounting Holes
3. Front
4. Top (with Labels)
5. Secure screws in the top mounting holes and the bottom mounting holes on each side of the controller tray.
6. Install the bezel on the front of the controller tray.
7. Install the drive trays. Refer to "[Step 7 – Connecting the Controller Tray to the Drive Trays](#)" for information about installing the FC4600 drive tray and the DE6900 drive tray.

Step 5 – Connecting the Controller Tray to the Hosts

Key Terms

access volume

A special volume that is used by the host-agent software to communicate management requests and event information between the management station and the storage array. An access volume is required only for in-band management.

direct topology

A topology that does not use a switch.

Dynamic Host Configuration Protocol (DHCP)

CONTEXT [Network] An Internet protocol that allows nodes to dynamically acquire ('lease') network addresses for periods of time rather than having to pre-configure them. DHCP greatly simplifies the administration of large networks, and networks in which nodes frequently join and depart. (The Dictionary of Storage Networking Terminology)

in-band management

A method to manage a storage array in which a storage management station sends commands to the storage array through the host input/output (I/O) connection to the controller.

out-of-band management

A method to manage a storage array in which a storage management station sends commands to the storage array through the Ethernet connections on the controller.

stateless address autoconfiguration

A method for setting the Internet Protocol (IP) address of an Ethernet port automatically. This method is applicable only for IPv6 networks.

switch topology

A topology that uses a switch.

topology

The logical layout of the components of a computer system or network and their interconnections. Topology deals with questions of what components are directly connected to other components from the standpoint of being able to communicate. It does not deal with questions of physical location of components or interconnecting cables. (The Dictionary of Storage Networking Terminology)

World Wide Identifier (WWID)

CONTEXT [Fibre Channel] A unique 64-bit number assigned by a recognized naming authority (often using a block assignment to a manufacturer) that identifies a node process or node port. A WWID is assigned for the life of a connection (device). Most networking physical transport network technologies use a world wide unique identifier convention. For example, the Ethernet Media Access Control Identifier is often referred to as the MAC address. (The Dictionary of Storage Networking Terminology)

Things to Know – Host Channels on the CE7900 Controller Tray

- Each controller has four dual-ported host channels.
- Each group of two channels is associated with one host interface card.
- Controller A is inverted from controller B, which means that its host channels are upside-down and numbered in reverse order.

Host Channels on the Controllers – Rear View

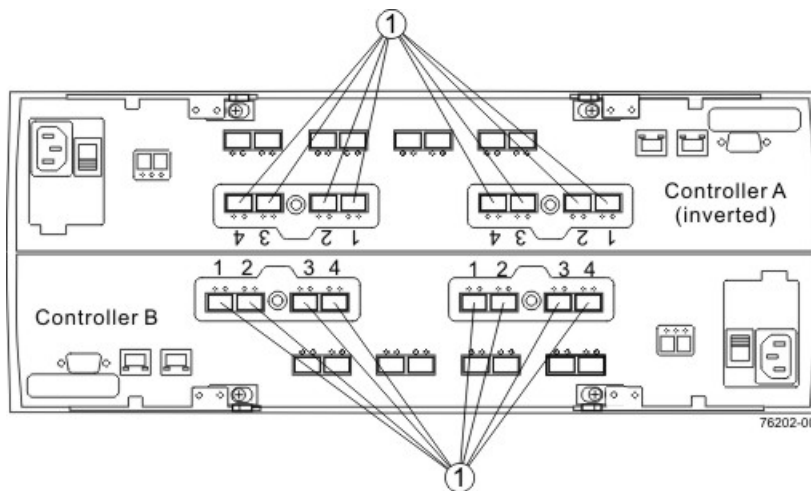

1. Host Channels

WARNING (W03) Risk of exposure to laser radiation – Do not disassemble or remove any part of a Small Form-factor Pluggable (SFP) transceiver because you might be exposed to laser radiation.

ATTENTION Possible hardware damage – To prevent electrostatic discharge damage to the tray, use proper antistatic protection when you handle tray components.

Things to Know – Host Interface Cards

The CE7900 controller tray supports several types of host interface cards (HICs) for different speeds and protocols. Keep these guidelines in mind:

- 20-Gb/s InfiniBand
- 10-Gb/s iSCSI
- 8-Gb/s Fibre Channel
- 4-Gb/s Fibre Channel
- 1-Gb/s iSCSI
- A CE7900 controller tray with InfiniBand HICs must have only InfiniBand HICs.
- If you connect a 4-Gb/s Fibre Channel HIC with an 8-Gb/s HBA on a host, the data transfer rate is 4 Gb/s.
- A controller might have a mix with one 4-Gb/s Fibre Channel HIC and one 8-Gb/s Fibre Channel HIC or it might have a mix with one Fibre Channel HIC and one 1-Gb/s iSCSI HIC or one 10-Gb/s iSCSI HIC.
- When HICs are mixed, each controller in a duplex system must have the exact same HIC configuration.

- When Fibre Channel HICs with different data rates are mixed and you are cabling for redundancy, cable the HBAs on the host to the HICs with the same data rate, one on controller A and one on controller B.

Procedure – Connecting Host Cables on the CE7900 Controller Tray

Make sure that you have installed your host adapters. Refer to the documentation for your host adapters for information about how to install the host adapter and how to use the supplied configuration utilities.

The figures in this section show Fibre Channel connections as examples and identify HBA1 and HBA2 as connecting points on the hosts. For other configurations, these connecting points might be host channel adapters (HCAs) for InfiniBand connections, Ethernet adapters for iSCSI connections, or a combination of one HBA and one iSCSI Ethernet adapter.

Fibre Channel and InfiniBand connections require fiber-optic cables. Connections for iSCSI require copper cables with RJ-45 connectors. The cabling patterns are the same for all types of cables and connectors.

 **IMPORTANT** Small Form-factor Pluggable (SFP) transceivers are required for Fibre Channel and InfiniBand host connections for 20-Gb/s InfiniBand, 10-Gb/s iSCSI, 8-Gb/s Fibre Channel, and 4-Gb/s Fibre Channel connections, each requires a different type of SFP transceiver. Be sure to use SFP transceivers that match the data rate and protocol for the connection that you are making.

This procedure is for a direct topology as shown in [Figure 1–1](#). See [Figure 1–2](#) and [Figure 1–3](#) for example cabling patterns for fabric and mixed topologies. A Fibre Channel host connections require SFP transceivers in the HIC and in the HBA.

1. If you are cabling a Fibre Channel connection, make sure that an SFP transceiver is inserted into the host port on the HIC and the corresponding port on the HBA in the host. Make sure that any black plastic plugs that might be present are removed from the SFP transceivers.
2. Starting with the first host channel of each controller, perform one of these actions:
 - For a Fibre Channel or an InfiniBand connection, plug one end of the cable into the SFP transceiver in a port.
 - For an iSCSI connection, plug the RJ-45 connector on one end of the cable directly into a port.
3. Plug the other end of the cable into one of the host adapter ports in the host.
 - For a Fibre Channel or an InfiniBand connection, plug one end of the cable into the SFP transceiver in a port.
 - For an iSCSI connection, plug the RJ-45 connector on one end of the cable directly into a port.

Make sure that the speed and protocol used by the host adapter match those used by the HIC.

4. Affix a label to each end of the cable with the following information. A label is very important if you need to disconnect cables to service a controller.
 - The host name and the host adapter port
 - The controller ID (for example, controller A)
 - The host channel ID (for example, host channel 1)

Example label abbreviation – Assume that a cable is connected between port 1 in HBA 1 of a host named Engineering and host channel 1 of controller A.

Heng-HBA1/P1, CtA-Hch1

 **NOTE** If you are cabling for a fabric or mixed topology, include the appropriate switch name and port number on the label.

- Repeat step 2 through step 4 for each controller and host channel that you intend to use.

 **NOTE** If you do not use a host channel, remove the SFP transceiver. You can use a 4-Gb/s SFP transceiver in a drive channel port or in an ESM on the drive tray.

Direct Topology – One Host and a Dual-Controller Controller Tray

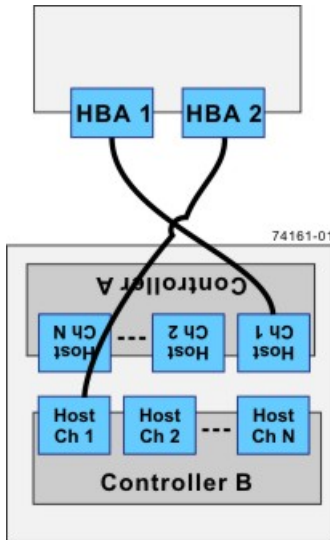

The box on the top in the preceding figure is the host, and the box on the bottom is the controller tray.

Fabric Topology – One Host and a Dual-Controller Controller Tray with a Switch

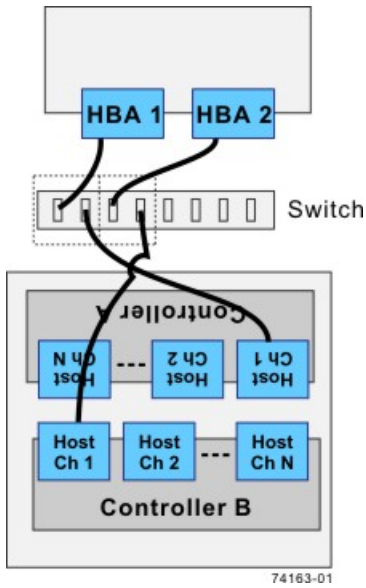

The box on the top of the switch in the preceding figure is the host, and the box on the bottom is the controller tray.

Mixed Topology – Three Hosts and a Dual-Controller Controller Tray

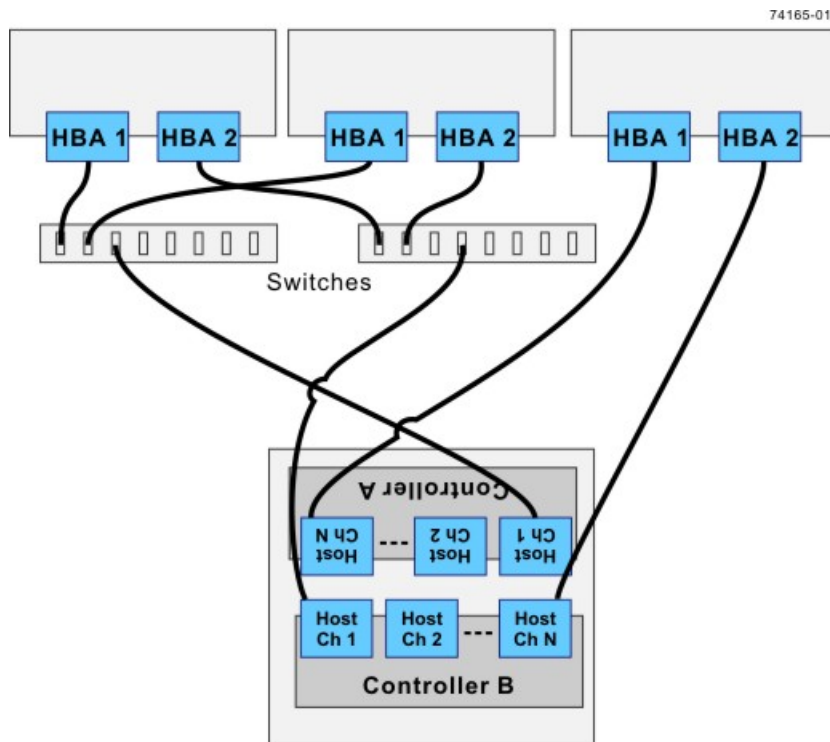

The boxes on the top of the switch in the preceding figure are the hosts, and the box on the bottom is the controller tray.



IMPORTANT The highest numbered host channel might be reserved for use with the Remote Volume Mirroring premium feature. If Remote Volume Mirroring connections are required, do not connect a host to the highest-numbered host channel.

Step 6 – Installing the Drive Trays for the CE7900 Controller Tray Configurations

Things to Know – General Installation of the CE7900 Controller Tray

- Special site preparation is not required for these trays beyond what is normally found in a computer lab environment.
- The power supplies meet standard voltage requirements for both domestic and worldwide operation.



IMPORTANT If you are installing the CE7900 controller tray in a cabinet with other drive trays, make sure that the combined power requirements of the controller tray and the other drive trays do not exceed the power capacity of your cabinet.

Things to Know – General Installation of the FC4600 Drive Tray



IMPORTANT After you install the drive tray, you might replace drives or install additional drives. If you replace or add more than one drive without powering down the drive tray, install the drives one at a time. Wait 10 seconds after you insert each drive before inserting the next one.

- If you are installing FC4600 drive trays and the CE7900 controller-drive tray at the same time, take these precautions:
 - Install the controller-drive tray in a location within the cabinet that lets you evenly distribute the drive trays around the controller-drive tray.
 - Keep as much weight as possible in the bottom half of the cabinet.



ATTENTION Potential damage to drives – Turning the power off and on without waiting for the drives to spin down can damage the drives. Always wait at least 60 seconds from when you turn off the power until you turn on the power again.

Things to Know – General Installation of the DE6900 Drive Tray



IMPORTANT After you install the drive tray, you might replace drives or install additional drives. If you replace or add more than one drive without powering down the drive tray, install the drives one at a time. Wait 10 seconds after you insert each drive before inserting the next one.

- If you are installing DE6900 drive trays and the CE7900 controller tray at the same time, take these precautions:
 - Keep as much weight as possible in the bottom half of the cabinet.
 - Install the DE6900 drive trays in the bottom of the cabinet, placing the controller tray directly above them.
 - Do not handle the drives in each of the five drawers of the DE6900 drive tray unless absolutely necessary.



ATTENTION Risk of bodily injury – Do not use equipment in the cabinet as a shelf or work space.



ATTENTION Risk of equipment damage – You must install the DE6900 drive tray must be installed in a cabinet before performing any service operations, such as operating or moving drawers. Place the DE6900 drive tray on a flat surface for transportation by using a cart or a mechanized lift.

 **ATTENTION Potential damage to drives** – Turning the power off and on without waiting for the drives to spin down can damage the drives. Always wait at least 60 seconds from when you turn off the power until you turn on the power again.

 **WARNING (W15) Risk of bodily injury** – An empty tray weighs approximately 56.7 kg (125 lb). Three persons are required to safely move an empty tray. If the tray is populated with components, a mechanized lift is required to safely move the tray.

For Additional Information on Drive Tray Installation

Refer to the *Storage System Site Preparation Guide* on the SANtricity ES Storage Manager Installation DVD for important considerations about cabinet installation.

Procedure – Installing the FC4600 Drive Tray

 **WARNING (W09) Risk of bodily injury** –



>35 kg (70.5 lbs)

Three persons are required to safely lift the component.

 **WARNING (W05) Risk of bodily injury** – If the bottom half of the cabinet is empty, do not install components in the top half of the cabinet. If the top half of the cabinet is too heavy for the bottom half, the cabinet might fall and cause bodily injury. Always install a component in the lowest available position in the cabinet.

Install the FC4600 drive tray into an industry standard cabinet.

This procedure describes how to install the mounting rails into an industry standard cabinet.

 **ATTENTION Possible hardware damage** – To prevent electrostatic discharge damage to the tray, use proper antistatic protection when handling tray components.

1. Make sure that the cabinet is in the final location. Make sure that you meet the clearance requirements shown below.

Drive Tray Airflow and Clearance Requirements

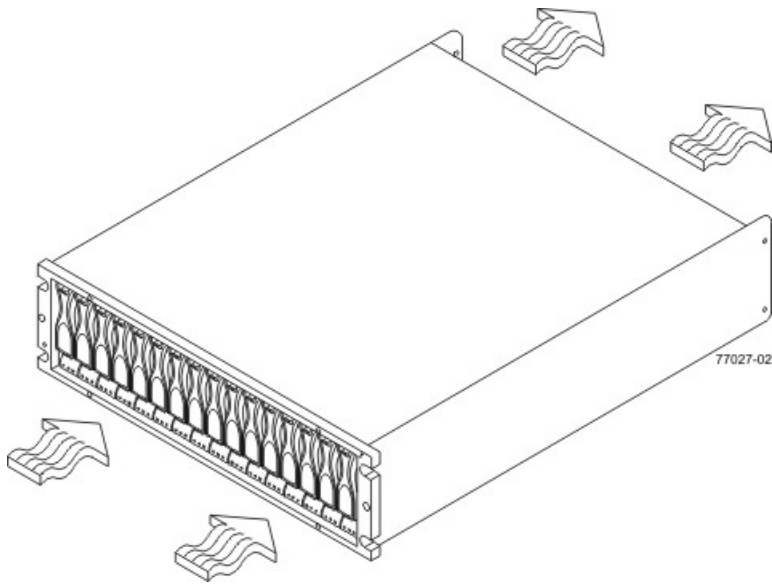

1. 76 cm (30 in.) clearance in front of the cabinet
2. 61 cm (24 in.) clearance behind the cabinet



NOTE Fans pull air through the tray from front to rear across the drives.

2. Lower the feet on the cabinet to keep the cabinet from moving.
3. Remove the drive tray and all contents from the shipping carton.
4. Position the mounting rails in the cabinet.

Positioning the Mounting Rails in the Cabinet

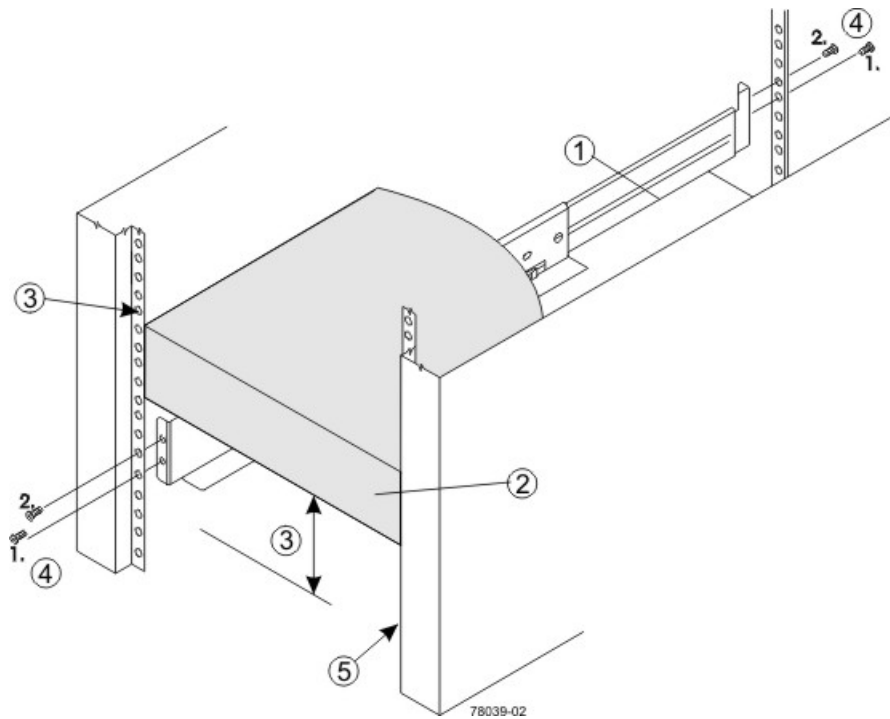

1. Mounting Rail
2. Existing Tray
3. Clearance Above and Below the Existing Tray
4. Screws for Securing the Mounting Rail to the Cabinet (Front and Rear)
5. Industry Standard Cabinet

- If you are installing the mounting rails above an existing tray, position the mounting rails directly above the tray.
 - If you are installing the mounting rails below an existing tray, allow 8.8-cm (3.5-in.) vertical clearance for the drive tray.
5. Attach the mounting rails to the cabinet by performing these substeps:
 - a. Make sure that the adjustment screws on the mounting rail are loose so that the mounting rail can extend or contract as needed.

Attaching the Mounting Rails to the Cabinet

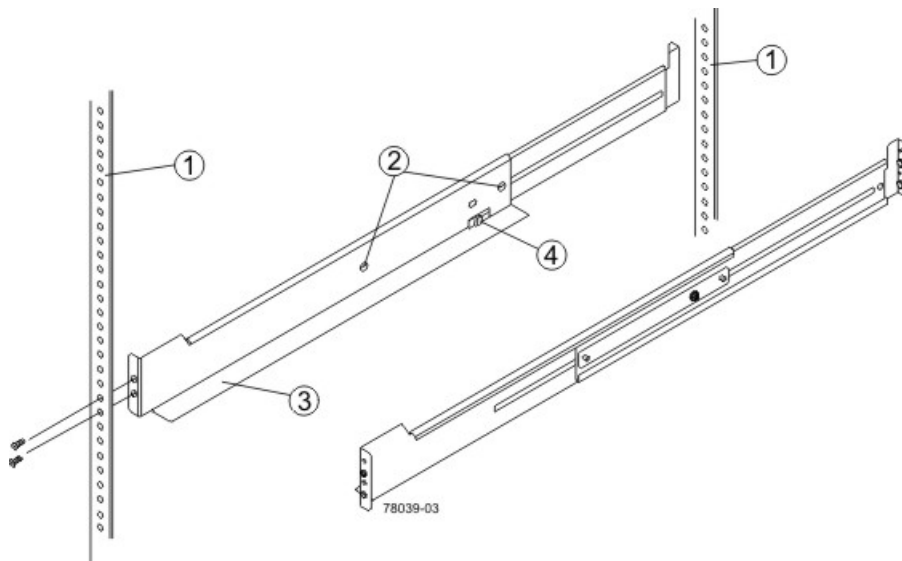

1. Cabinet Mounting Holes
 2. Adjustment Screws for Locking the Mounting Rail Length
 3. Mounting Rails
 4. Clip for Securing the Rear of the Drive Tray
- b. Place the mounting rail inside the cabinet, and extend the mounting rail until the flanges on the mounting rail touch the inside of the cabinet.
- c. Make sure that the alignment spacers on the front flange of the mounting rail fit into the mounting holes in the cabinet.

The front flange of each mounting rail has two alignment spacers. The alignment spacers are designed to fit into the mounting holes in the cabinet. The alignment spacers help position and hold the mounting rail.

Alignment Spacers on the Mounting Rail

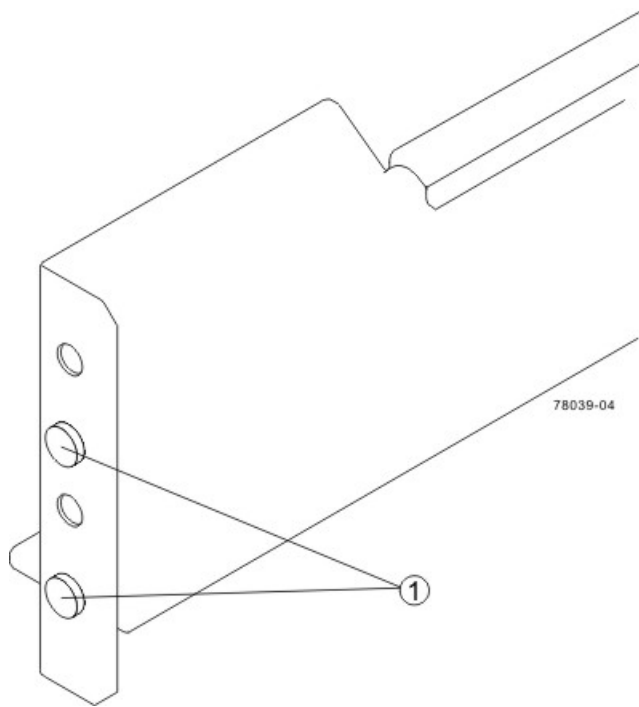

1. Alignment Spacers
 - d. Insert one M5 screw through the front of the cabinet and into the top captured nut in the mounting rail. Tighten the screw.
 - e. Insert two M5 screws through the rear of the cabinet and into the captured nuts in the rear flange in the mounting rail. Tighten the screws.
 - f. Tighten the adjustment screws on the mounting rail.
 - g. Repeat substep a through substep f to install the second mounting rail.
6. With the help of two other persons, slide the rear of the drive tray onto the mounting rails.

The mounting holes on the front flanges of the drive tray align with the mounting holes on the front of the mounting rails.
7. Secure the front of the drive tray to the cabinet by using four screws.

Attaching the Front of the Drive Tray

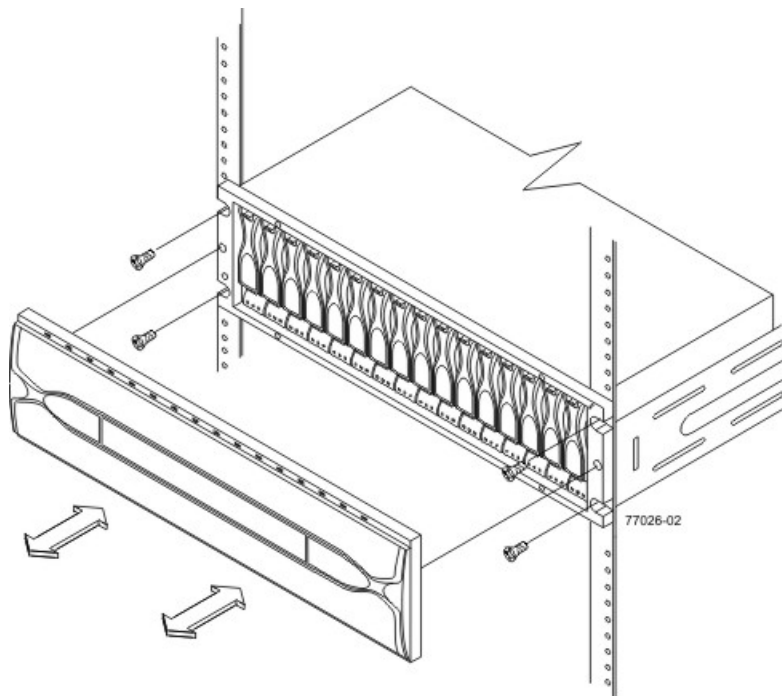

1. Screws for Securing the Front of the Drive Tray
8. Using two screws, attach the flange on each side of the rear of the drive tray to the mounting rails.

Procedure – Installing Drives for the FC4600 Drive Tray

In some situations, the drive tray might be delivered without the drives installed. Follow the steps in this procedure to install the drives. If your drive tray already has drives installed, you can skip this step and go to [“Things to Know – AC Power Cords”](#).

⚠ ATTENTION Risk of equipment malfunction – To avoid exceeding the functional and environmental limits, install only drives that have been provided or approved by the original manufacturer. Drives might be shipped but not installed. System integrators, resellers, system administrators, or users can install the drives.

NOTE The installation order is from left to right. The installation order is important because the drives might already contain configuration information that depends upon the correct sequence of the drives in the tray.

1. Beginning with the first drive slot in the left side of the drive tray, place the drive on the slot guides, and slide the drive all the way into the slot.
2. Push the drive handle down to lock the drive securely in place.

Installing a Drive in a FC4600 Drive Tray

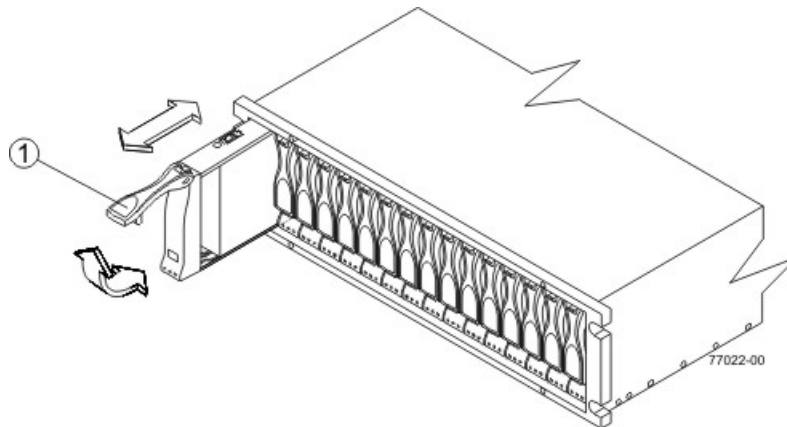

1. Drive Handle

3. Install the second drive to the right of the first drive.
4. Install each drive to the right of the last installed drive.

Things to Know – Link Rate Switch on the FC4600 Drive Tray

IMPORTANT Change the **Link Rate** switch only when the power is not turned on to the drive tray.

- Use the **Link Rate** switch to select the data transfer rate between the ESMs, the drives, and the controllers. The **Link Rate** switch is located on the rear of the drive tray on the ESMs.
- All drive trays that are connected to the same drive channel must be set to operate at the same data transfer rate (speed).
- The drives in the drive tray must support the selected link rate speed.
- The setting of the **Link Rate** switch determines the speed of the drives.
- If a drive in the drive tray does not support the link rate speed, the drive will show up as a bypassed drive in the storage management software.

IMPORTANT Change the **Link Rate** switch only when no power is applied to the drive tray.

Setting the Link Rate Switch on the FC4600 Drive Tray – Front View

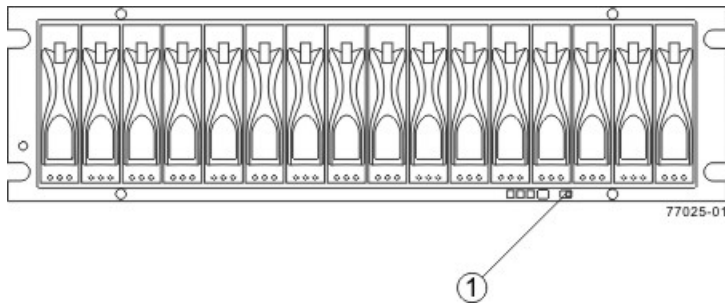

1. Link Rate Switch (4 Gb/s or 2 Gb/s)

Link Rate LEDs on the FC4600 Drive Tray – Rear View

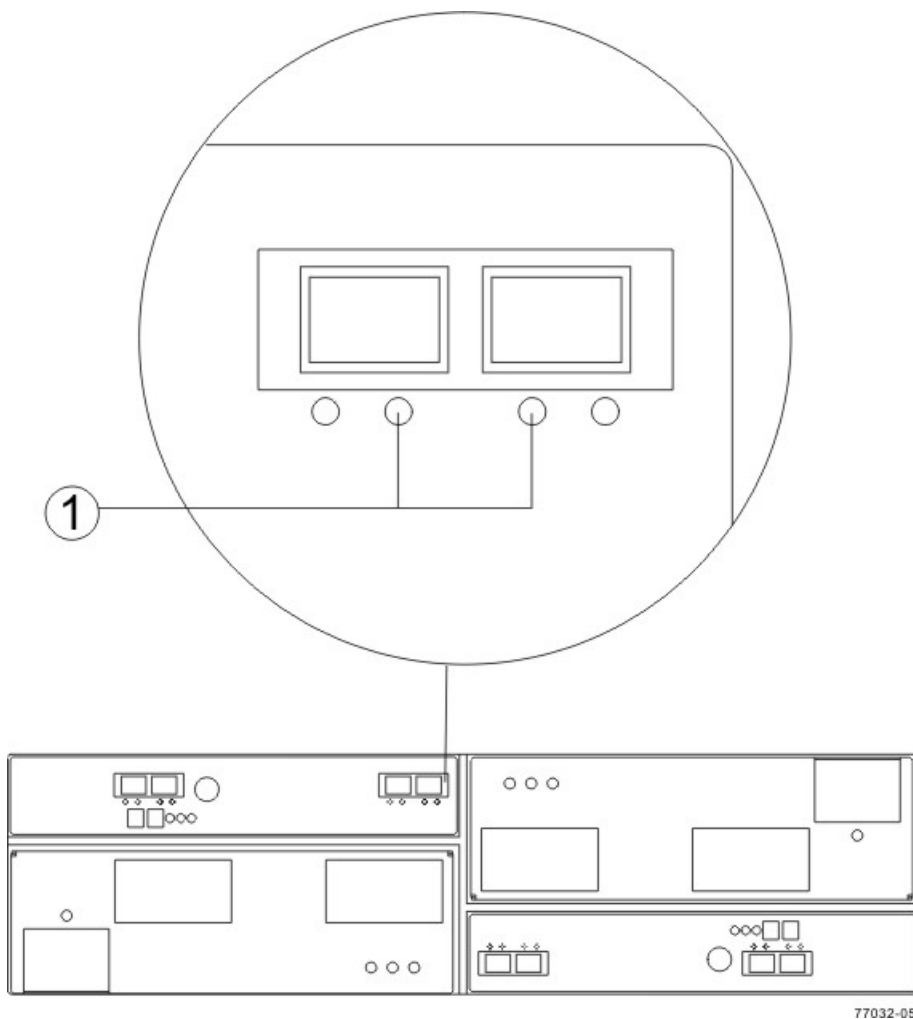

1. Link Rate LEDs Right On = 2 Gb/s Left and Right On = 4 Gb/s

Procedure – Setting the Link Rate Switch on the FC4600 Drive Tray

1. Check to see if the **Link Rate** switch is set to the 4-Gb/s data transfer rate.
 - If the link rate is set to 4-Gb/s, you do not need to change the setting.
 - If the link rate is set to 2-Gb/s, go to step 2.

2. Make sure that no power is applied to the drive tray.
3. Move the switch to the 4-Gb/s (left) position.

Steps to Install – DE6900 Drive Tray

Install the DE6900 drive tray an industry standard cabinet that has a depth of 100 cm (40 in.).

A minimum depth of 76 cm (30 in.) must exist between the front EIA support rails and the rear EIA support rails.

1. Make sure that the cabinet is in the final location. Make sure that you meet the clearance requirements shown in the following figure.

Drive Tray Airflow and Clearance Requirements for the DE6900 Drive Tray

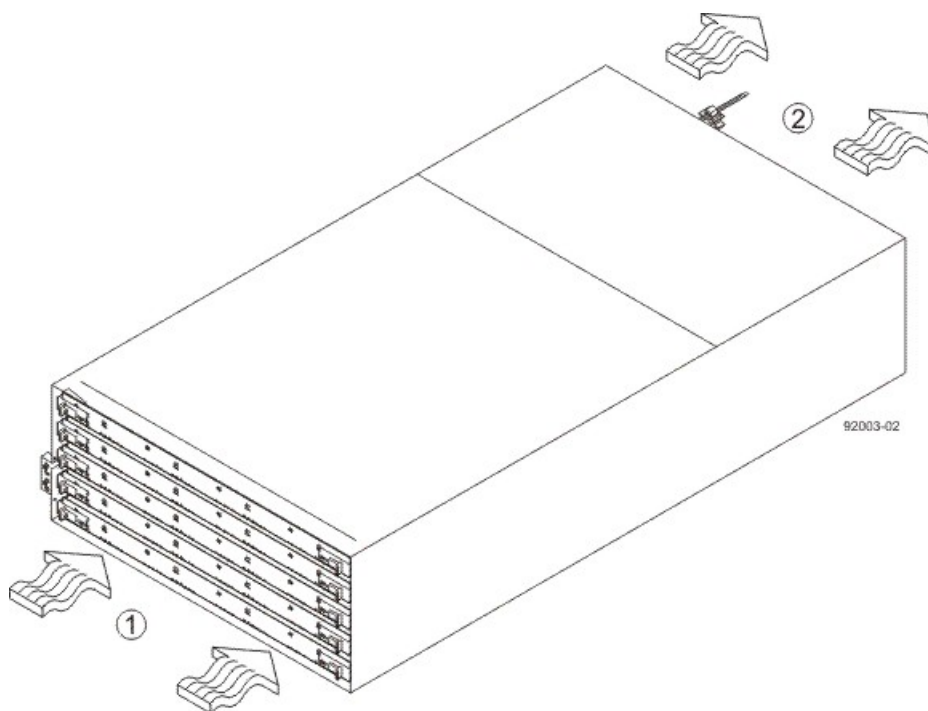

1. 81 cm (32 in.) clearance in front of the cabinet
2. 61 cm (24 in.) clearance behind the cabinet



NOTE Fans pull air through the drive tray from front to rear across the drives.

2. Lower the feet on the cabinet to keep the cabinet from moving.



WARNING (W09) Risk of bodily injury –



>35 kg (70.5 lbs)

Three persons are required to safely lift the component.



WARNING (W15) Risk of bodily injury – An empty tray weighs approximately 56.7 kg (125 lb). Three persons are required to safely move an empty tray. If the tray is populated with components, a mechanized lift is required to safely move the tray.

3. With the help of at least two other persons, remove the drive tray and all of the contents from the shipping carton, using the four drive tray handles (two to a side) as shown in the following figure. Set the drive tray aside.

DE6900 Drive Tray with Drive Tray Handles (Two on Each Side)

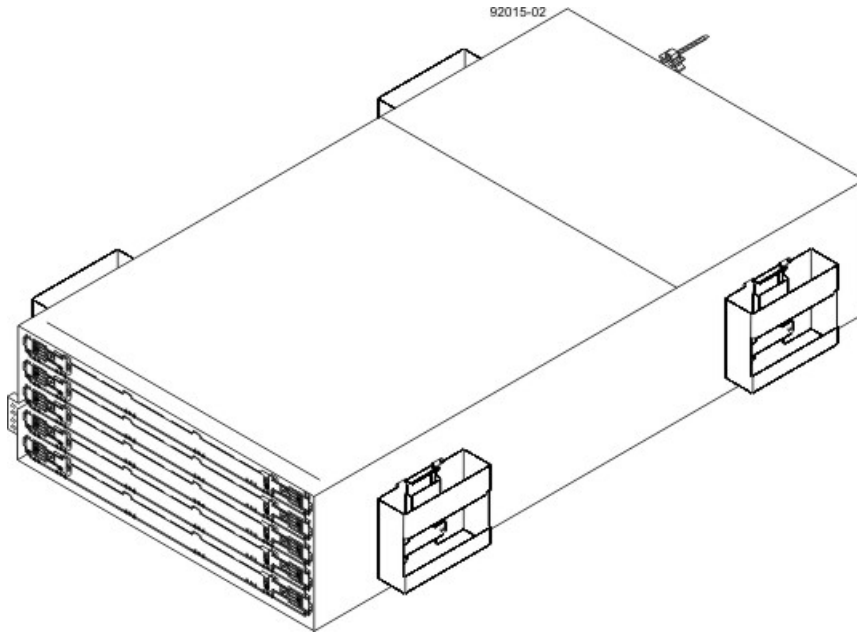

4. Position the mounting rails in the cabinet.

Positioning the DE6900 Mounting Rails in the Cabinet

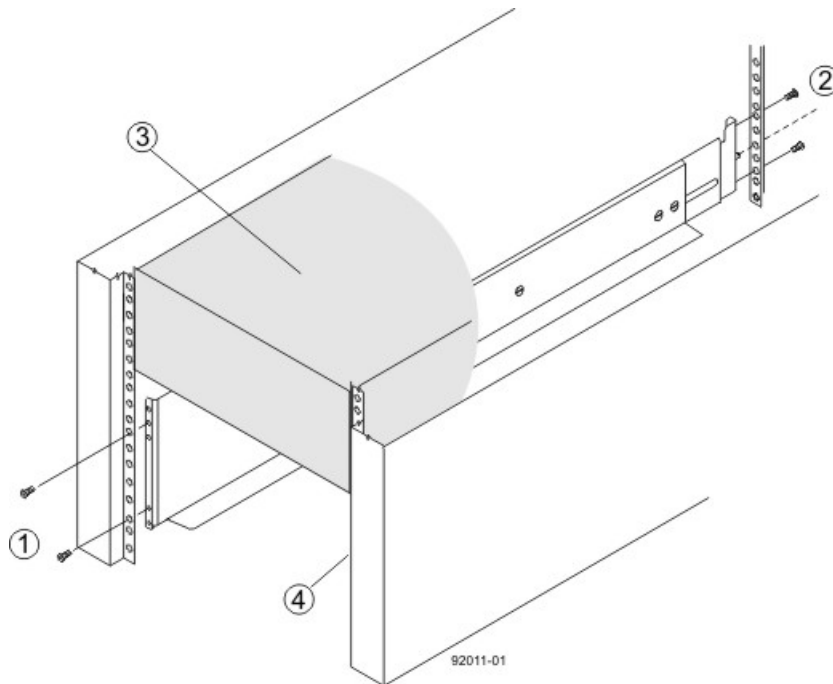

1. Screws for Securing the Mounting Rail to the Cabinet (Front)
 2. Screws for Securing the Mounting Rail to the Cabinet (Rear)
 3. Existing Tray
 4. Industry Standard Cabinet
- If you are installing the mounting rails above an existing tray, position the mounting rails directly above the tray.
 - If you are installing the mounting rails below an existing tray, allow 17.8-cm (7-in.) vertical clearance for a DE6900 drive tray.
5. To attach the mounting rails to the cabinet, perform these substeps:
 - a. Make sure that the adjustment screws on the mounting rail are loose so that the mounting rail can extend or contract as needed.

Attaching the Mounting Rails to the Cabinet

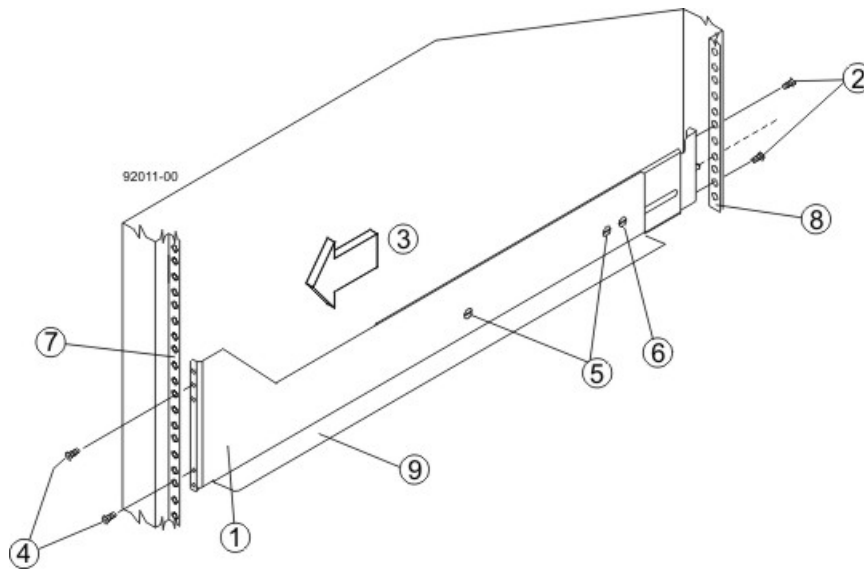

1. Front of the Mounting Rail
 2. Two M4 Screws for the Rear EIA Support Rail
 3. Front of the Cabinet
 4. Two M5 Screws for the Front EIA Support Rail
 5. Adjustable Rail Tightening Screws
 6. Rear Hold-Down Screw
 7. Cabinet Mounting Holes on the Front EIA Support Rail
 8. Cabinet Mounting Holes on the Rear EIA Support Rail
 9. Mounting Rail Lip
- b. Remove the rear hold-down screw. It protrudes from the inside of the rail and prevents you from sliding the drive tray onto the rails.
 - c. Place the mounting rail inside the cabinet, and extend the mounting rail until the flanges on the mounting rail touch the inside of the cabinet.
 - d. Insert one M5 screw through the front of the cabinet, and screw it into the top captured nut in the mounting rail.
 - e. Insert two M4 screws through the rear of the cabinet, and screw them into the captured nuts in the rear flange in the mounting rail.
 - f. Tighten the adjustment screws on the mounting rail.
 - g. Repeat substep a through substep f to install the second mounting rail.
 - h. Insert one M5 screw through the front of the mounting rail. This screw will attach the drive tray to the cabinet.
6. Remove the bezel from the front of the drive tray.

**WARNING**

(W09) **Risk of bodily injury** –



>35 kg (70.5 lbs)

Three persons are required to safely lift the component.



WARNING (W15) Risk of bodily injury – An empty tray weighs approximately 56.7 kg (125 lb). Three persons are required to safely move an empty tray. If the tray is populated with components, a mechanized lift is required to safely move the tray.

7. With the help of at least two other persons, slide the rear of the drive tray onto the mounting rails. The drive tray is correctly aligned when the mounting holes on the front flanges of the drive tray align with the mounting holes on the front of the mounting rails.
8. After the drive tray is correctly aligned, use your thumb to unlatch the four drive handles (two to a side), and remove the handles from the drive tray, from the rear to the front as shown in the following figure.

Removing a Drive Handle from the DE6900 Drive Tray

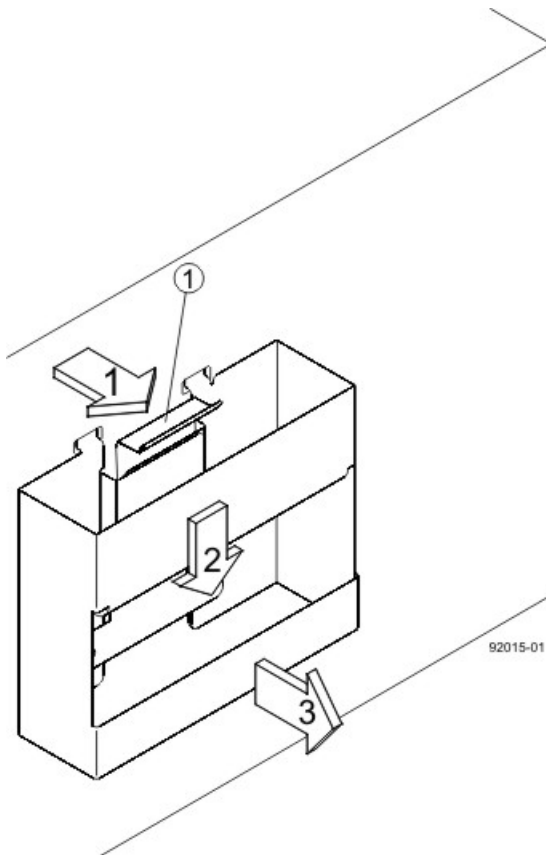

1. Pull the thumb latch away from the drive tray to detach the hook.
 2. Shift the handle down to release the other four hooks.
 3. Move the handle away from the drive tray.
9. Secure the front of the drive tray to the cabinet. Use the four screws to attach the flange on each side of the front of the drive tray to the mounting rails.
 - a. Insert two 10-32 screws through the bottom holes of a flange on the drive tray so that the screws go through the EIA support rail and engage the bottom captured nuts in the mounting rail. Tighten the screws.
 - b. Repeat substep a for the second flange.

Attaching the Front of the DE6900 Drive Tray

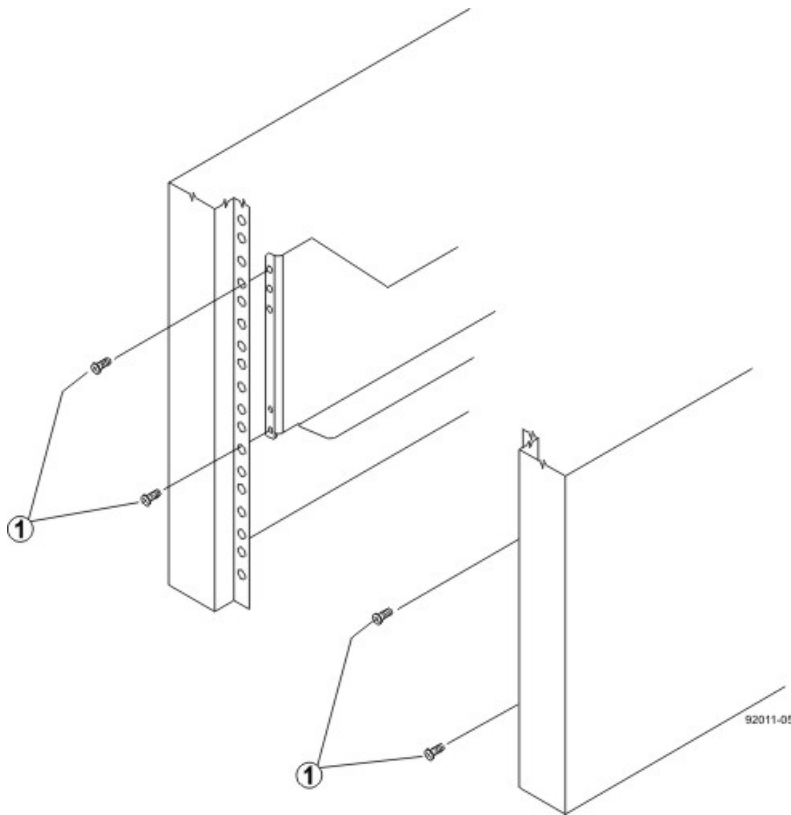

1. Four Screws for Securing the Front of the Drive Tray

10. Secure the side of the drive tray to the mounting rails by performing these substeps:

- a. Insert a 10-32 screw through the side sheet metal of the drive tray into the captured nut on the side of the mounting rail. Tighten the screws.
- b. Repeat substep a for the other side.



NOTE After the drive tray is installed, make sure that seven screws are on each side (right and left) of the cabinet.



NOTE Make sure that each drive drawer in the drive tray is securely fastened to ensure correct air flow to the drives.

Securing the DE6900 Drive Tray to the Rails

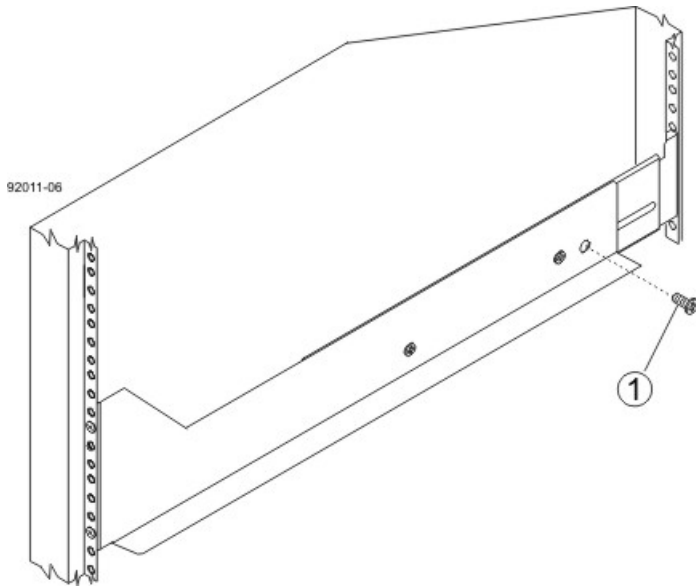

1. 10-32 Screw

DE6900 Drive Tray Installed in the Cabinet

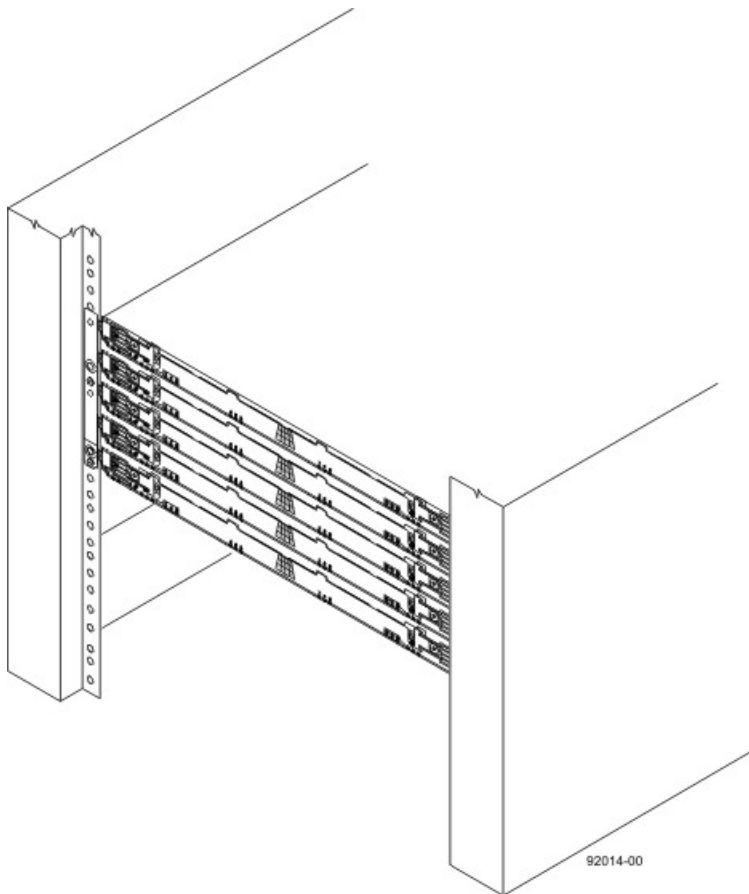

11. Attach the bezel onto the front of the drive tray.

Procedure – Installing Drives in the DE6900 Drive Tray

The DE6900 drive tray is shipped with the drive drawers installed, but the drives are not installed. Follow the steps in this procedure to install the drives.

⚠ ATTENTION Risk of equipment malfunction – To avoid exceeding the functional and environmental limits, install only drives that have been provided or approved by the original manufacturer. Drives might be shipped but not installed. System integrators, resellers, system administrators, or users can install the drives.

📌 IMPORTANT The installation order within each drawer is from left to right in rows. Slots 1, 4, 7 and 10 must have a drive installed in these locations to make sure there is sufficient air flow to the drives. To verify these slots, consult the overlay on the front of each of the five drive drawers. Make sure the four drives in each row are adjacent to each other. The long edge of each drive should touch the drive next to it. To maintain a uniform airflow across all drive drawers, the drive tray must be configured with a minimum of 20 drives, with four drives in the front row of each of the five drive drawers.

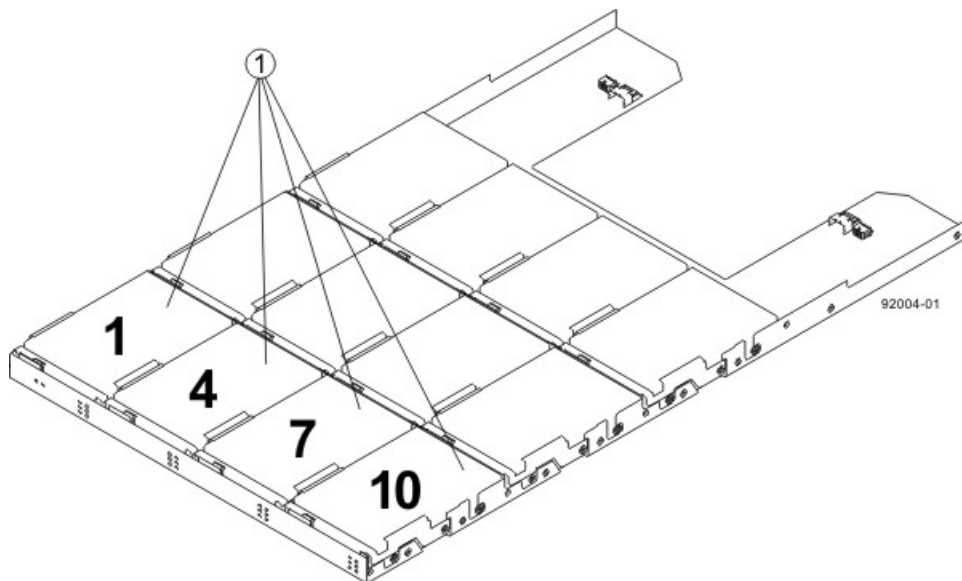

1. Slots 1, 4, 7, and 10 in the DE6900 Drive Tray

⚠ ATTENTION Risk of equipment malfunction – For the DE6900 drive tray, you can only replace one canister or drive at a time. Refer to the “Replacing a Failed Drive” instructions on the SANtricity ES Storage Manager Installation DVD, and make sure you have the replacement drive in hand before starting the task.

1. Starting with the top drawer in the drive tray, release the levers on each side of the drawer by pulling both towards the center.

Levers on the Drive Drawer



2. Pull on the extended levers to pull the drive drawer out to its full extension without removing it from the drive tray.
3. Starting with the first drive, raise the drive handle to the vertical position.

Raised Drive Handle

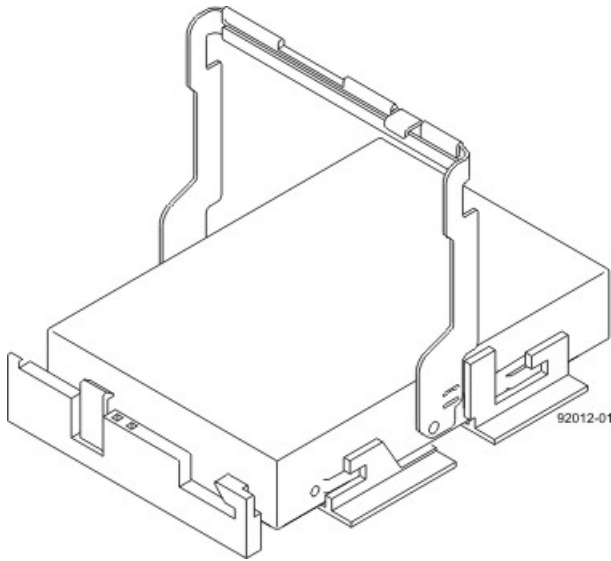

4. Align the two raised buttons on each side over the matching gap in the drive channel on the drawer.

Side View of Drive with Raised Handle

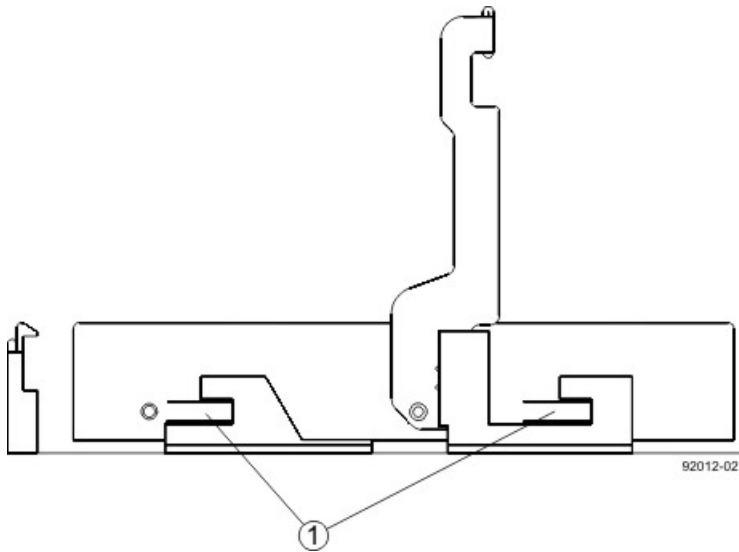

1. Raised Buttons

5. Lower the drive straight down, and then rotate the drive handle down until the drive snaps into place under the drive release lever.

Drive Release Lever Locked by the Drive Handle

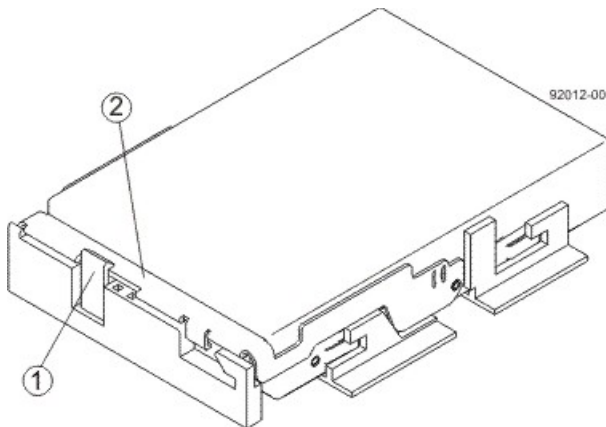

1. Drive Release Lever
2. Drive Handle

6. Install the other drives in rows from left to right, front to back, until the drive drawer is fully populated.

Fully-Populated Drive Drawer

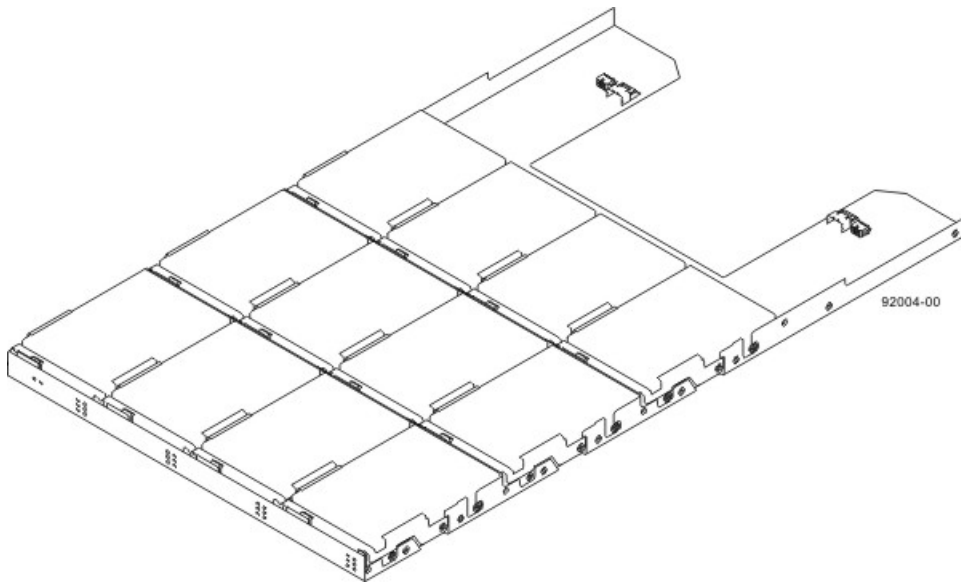

7. Push the drive drawer all the way back into the drive tray, and close the levers on each side of the drive drawer.



ATTENTION Risk of equipment malfunction – Make sure you push both levers to each side so that the drive drawer is completely closed. The drive drawer must be completely closed to prevent excess airflow, which has the potential to damage the drives.

8. Continue onto the next drive drawer, repeating step 1 through step 7 for each drive drawer in the configuration.

Step 7 – Connecting the Controller Tray to the Drive Trays

Key Terms

drive channel

The path for the transfer of data between the controllers and the drives in the storage array.

trunked connection

A connected device pair with two or more cables connecting the two devices. In other words, each device has two or more channel ports that are connected to two or more channel ports on the other device.

Things to Know – CE7900 Controller Tray

WARNING (W03) Risk of exposure to laser radiation – Do not disassemble or remove any part of a Small Form-factor Pluggable (SFP) transceiver because you might be exposed to laser radiation.

ATTENTION Possible hardware damage – To prevent electrostatic discharge damage to the tray, use proper antistatic protection when you handle tray components.

- The CE7900 controller tray supports only FC4600 drive trays and DE6900 drive trays. You cannot connect any other type of drive tray to the controller tray.
- Each controller has four drive channels, and each drive channel has two ports, so each controller has eight drive ports.
- Controller A is inverted from controller B, which means that its drive channels are upside-down and numbered in reverse.

Drive Channel Ports on the Controller Tray – Rear View

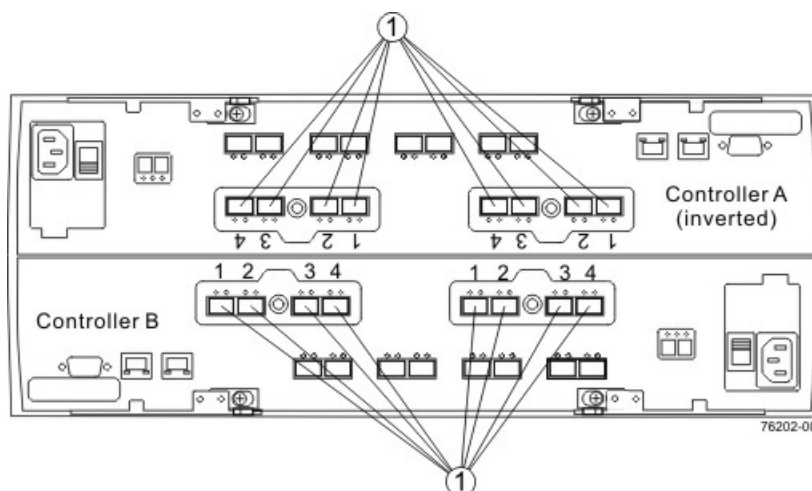

1. Drive Channel Ports

- A controller tray has eight redundant path pairs that are formed using one drive channel of controller A and one drive channel of controller B. The following figure shows the redundant pairs in a controller tray. The following table lists the numbers of the redundant path pairs and the drive ports of the drive channels from which the redundant path pairs are formed.



IMPORTANT To maintain data access in the event of the failure of a controller, an ESM, or a drive channel, you must connect a drive tray or a string of drive trays to both drive channels on a redundant path pair.

Redundant Path Pairs on the Controller Tray

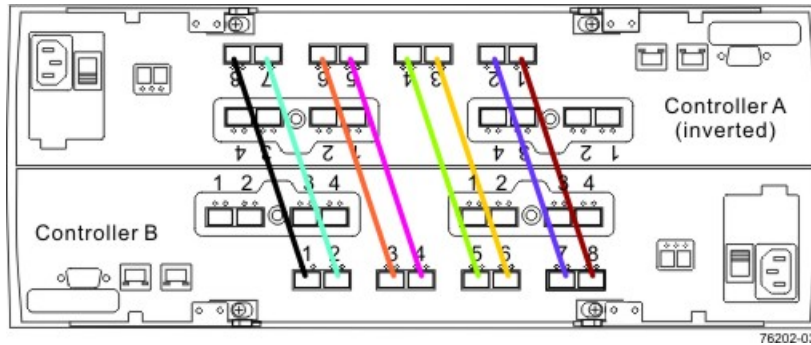

Redundant Path Pairs on a Controller Tray

| Drive Ports on Controller A | Drive Channels on Controller A | Drive Ports on Controller B | Drive Channels on Controller B |
|-----------------------------|--------------------------------|-----------------------------|--------------------------------|
| Port 8 | Channel 1 | Port 1 | Channel 5 |
| Port 7 | Channel 1 | Port 2 | Channel 5 |
| Port 6 | Channel 2 | Port 3 | Channel 6 |
| Port 5 | Channel 2 | Port 4 | Channel 6 |
| Port 4 | Channel 3 | Port 5 | Channel 7 |
| Port 3 | Channel 3 | Port 6 | Channel 7 |
| Port 2 | Channel 4 | Port 7 | Channel 8 |
| Port 1 | Channel 4 | Port 8 | Channel 8 |

Things to Know – DE6900 Drive Tray

Each DE6900 drive tray can contain a maximum of 60 drives. The ESMs on the DE6900 drive tray contain two sets of In and Out ports, one set for standard cabling and another for use with drive-side trunking. This document describes standard cabling. Refer to the *Hardware Cabling* electronic document topics or the SANtricity ES Storage Manager Installation DVD for information on cabling with drive-side trunking.

The DE6900 drive tray is large and heavy. It requires special handling for installation. For more information, refer to "[Steps to Install – DE6900 Drive Tray](#)".

DE6900 Drive Tray – Rear View

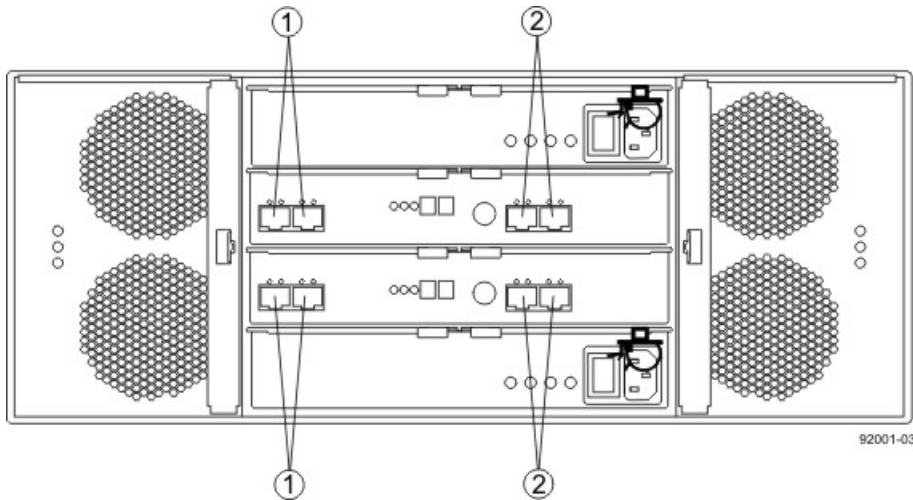

1. Standard In and Out Ports
2. Drive-Side Trunking In and Out Ports

Things to Know – FC4600 Drive Tray

- Each FC4600 drive tray can contain a maximum of 16 drives.
- The ESMs on the FC4600 drive tray contain two sets of In and Out ports (labeled 1A and 1B and 2A and 2B). *Use only port 1A and port 1B.* Port 2A and port 2B are reserved for future use.

 **NOTE** Make sure that an SFP transceiver is not inserted into port 2A or port 2B of the ESMs. The amber LED on the ESM comes on if an SFP transceiver is inserted in any of these ports.

- ESM B is installed right-side-up, and ESM A is installed upside-down. Keep this in mind when you connect cables to this drive tray.

FC4600 Drive Tray – Rear View

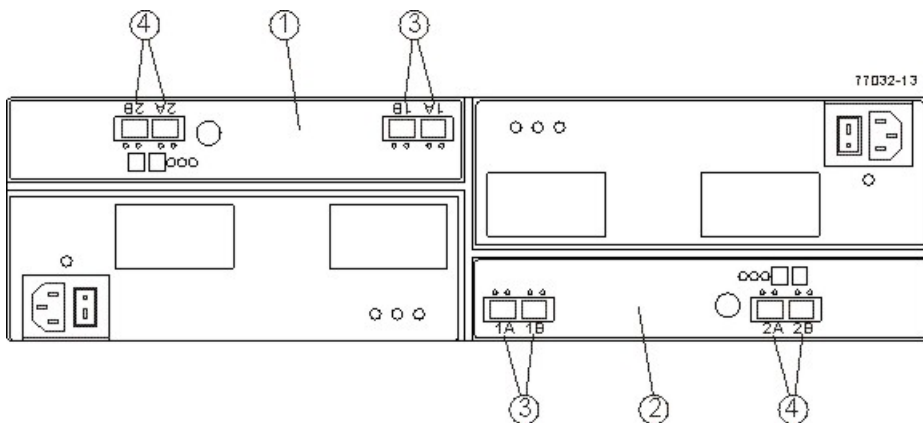

1. ESM A (Inverted)
2. ESM B
3. Port 1A (In) and Port 1B (Out)
4. Port 2A and Port 2B (Reserved)

Things to Know – Mixing Drive Tray Types

When a mix of FC4600 drive trays and DE6900 drive trays is cabled to the controller tray, the total number of drives must not exceed 448. If FC4600 drive trays and DE6900 drive trays are mixed on the same loop, the loop must not have more than two DE6900 drive trays or more than seven FC4600 drive trays.

Things to Know – Connecting the Drive Trays

Cable drive trays to the controller tray by using fiber-optic cables with Small Form-factor Pluggable (SFP) transceivers for 4-Gb/s Fibre Channel connections. The figures in "[Procedure – Connecting DE6900 Drive Trays and FC4600 Drive Trays to the CE7900 Controller Tray](#)" shows representative configurations for standard cabling.

You can cable the CE7900 controller tray to DE6900 drive trays, FC4600 drive trays, or a combination of the two. No more than seven FC4600 drive trays may be cabled to one loop pair and no more than 28 total FC4600 drive trays may be cabled to the controller tray. No more than two DE6900 drive trays may be cabled to one loop pair and no more than eight total DE6900 drive trays may be cabled to the controller tray.

If you are adding the drive tray to an existing storage array, look at the storage array profile for your storage array. The storage array profile shows information about the number of drive trays that are supported by your storage array. The storage array profile shows this information:

- The number of drive trays that are currently attached to the storage array
- The number of drive trays that you are allowed to add to the storage array

 **IMPORTANT** Do not add more drive trays than the storage array supports. Adding more drive trays makes the storage array invalid. You cannot perform configuration operations, but you can continue to transfer I/O data to the existing volumes.

HotScale™ technology lets you configure, reconfigure, add, or relocate storage array capacity without interrupting user access to data. Contact a Customer and Technical Support representative before proceeding. Refer to the on the SANtricity ES Storage Manager Installation DVD for more information.

 **ATTENTION Possible loss of data access** – Contact a Customer and Technical Support representative if you plan to add a drive tray to an existing storage array under either of the following conditions: The power is not turned off to the controller tray, or data transfer continues to the storage array.

Procedure – Connecting DE6900 Drive Trays and FC4600 Drive Trays to the CE7900 Controller Tray

 **NOTE** This procedure describes standard cabling for the DE6900 drive tray and the FC4600 drive tray. Drive-side trunking for the DE6900 drive tray follows a different pattern. Refer to either the *Hardware Cabling* electronic document topics or to the PDF on the SANtricity ES Storage Manager Installation DVD for information on how to cable for drive-side trunking.

1. Insert an SFP transceiver into the drive channel port, and plug one end of the fiber-optic cable into the drive channel port.

 **NOTE** Before you use an SFP transceiver, if a black, plastic plug is in the port where the SFP transceiver will be inserted, remove the plug.

2. Insert an SFP transceiver into the applicable In (1A) port or Out (1B) port on the ESM in the drive tray, and plug the other end of the fiber-optic cable into the applicable In (1A) port or Out (1B) port.
3. Affix a label to each end of the cable using this recommended scheme. A label is useful if you need to disconnect cables later to service a controller.
 - The controller ID (for example, controller A)
 - The drive channel number and the port ID (for example, drive channel 1, port 4)
 - The ESM ID (for example, ESM A)
 - The ESM port ID (for example, 1A or 1B)
 - The drive tray ID

Example label abbreviation– Assume that a cable is connected between drive channel 1, port 4, of controller A to the Out (1B) port of the left ESM (A) in drive tray 1. A label abbreviation could be as follows.

CtA-Dch1/P4, Dm1-ESM_A(left), 1B

4. Repeat step 1 through step 3 for each controller and drive channel that you intend to use.

NOTE You must connect the cables from one drive tray to the next (daisy-chaining), starting with the ninth FC4600 drive tray. If only DE6900 drive trays are used, all drive trays up to the maximum of eight are connected directly to the CE7900 controller tray for standard cabling.

Example: In the cabling configuration figures that follow, the controller tray is placed in the center, and the controllers are labeled as A and B. The FC4600 drive trays are placed above the controller tray and below the controller tray. The DE6900 drive trays are placed below the controller tray, beginning at the bottom of the cabinet. The drive trays are labeled as 1, 2, 3, and so on.

One CE7900 Controller Tray and One DE6900 Drive Tray

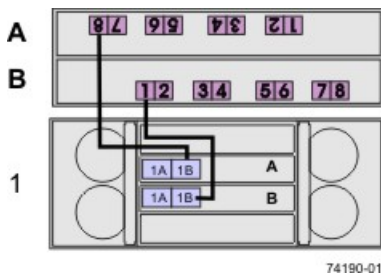

One CE7900 Controller Tray and Two DE6900 Drive Trays

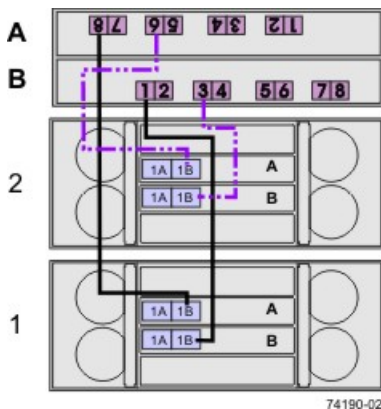

One CE7900 Controller Tray and Two FC4600 Drive Trays

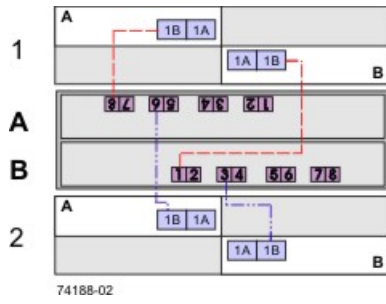

One CE7900 Controller Tray and Three DE6900 Drive Trays

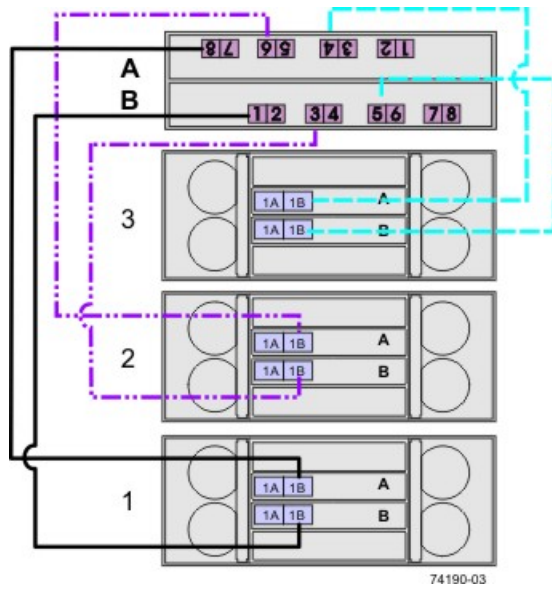

One CE7900 Controller Tray and Four DE6900 Drive Trays

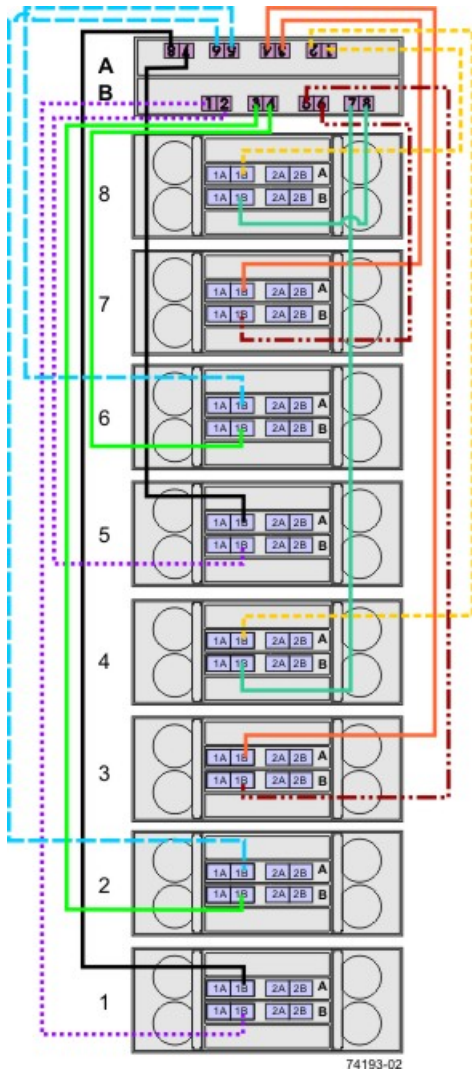

One CE7900 Controller Tray and Four FC4600 Drive Trays

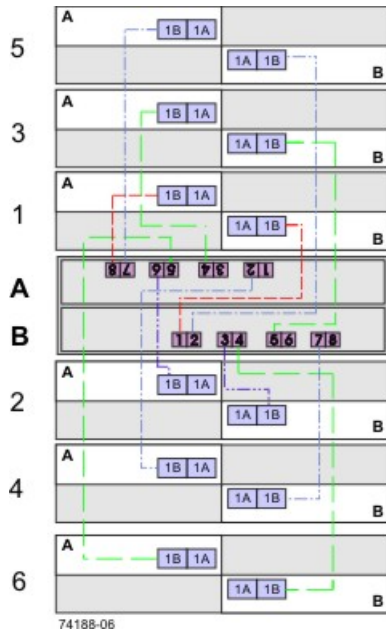

One CE7900 Controller Tray and Six FC4600 Drive Trays

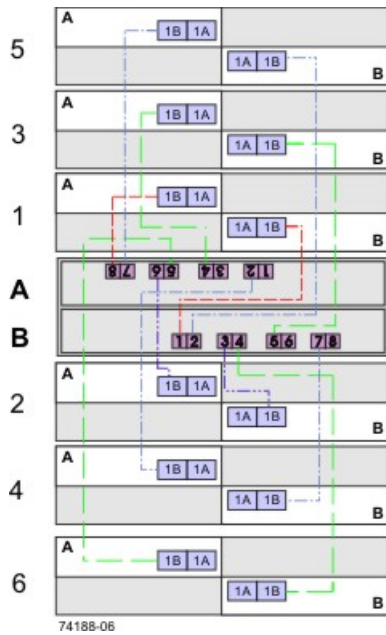

One CE7900 Controller Tray and Eight DE6900 Drive Trays

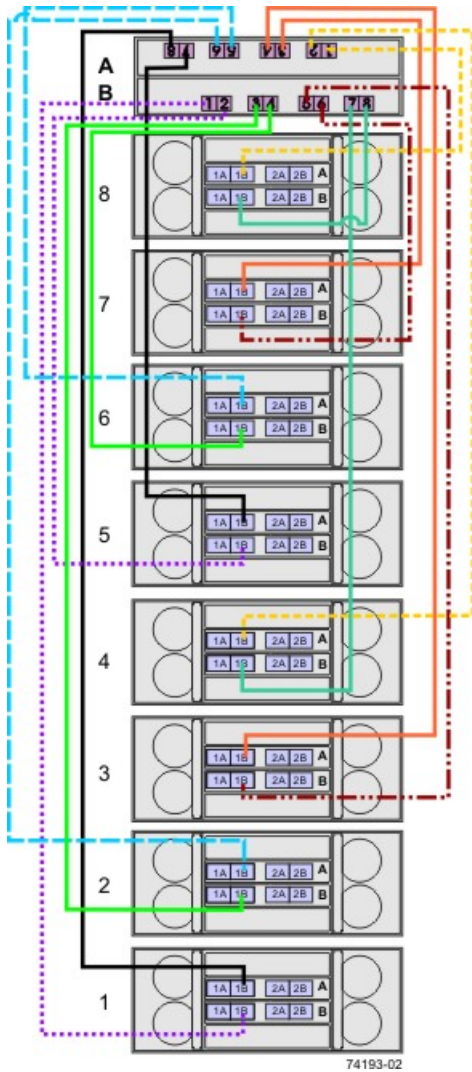

One CE7900 Controller Tray and Eight FC4600 Drive Trays

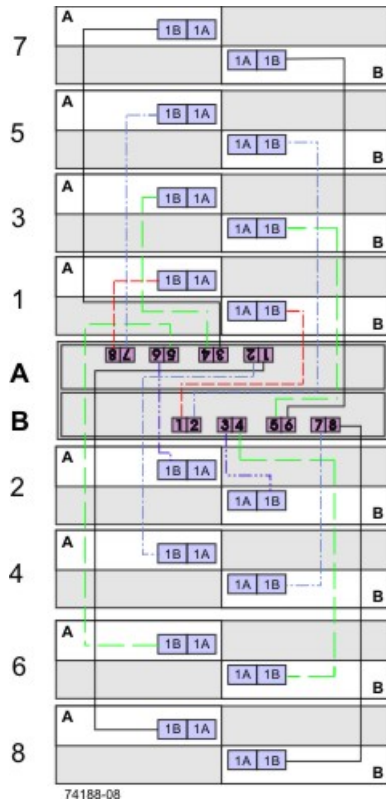

One CE7900 Controller Tray and 10 FC4600 Drive Trays

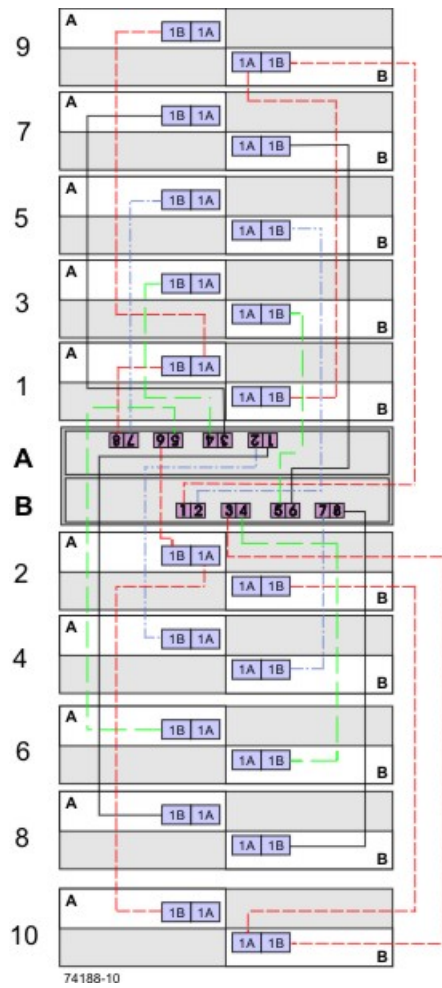

One CE7900 Controller Tray and 12 FC4600 Drive Trays

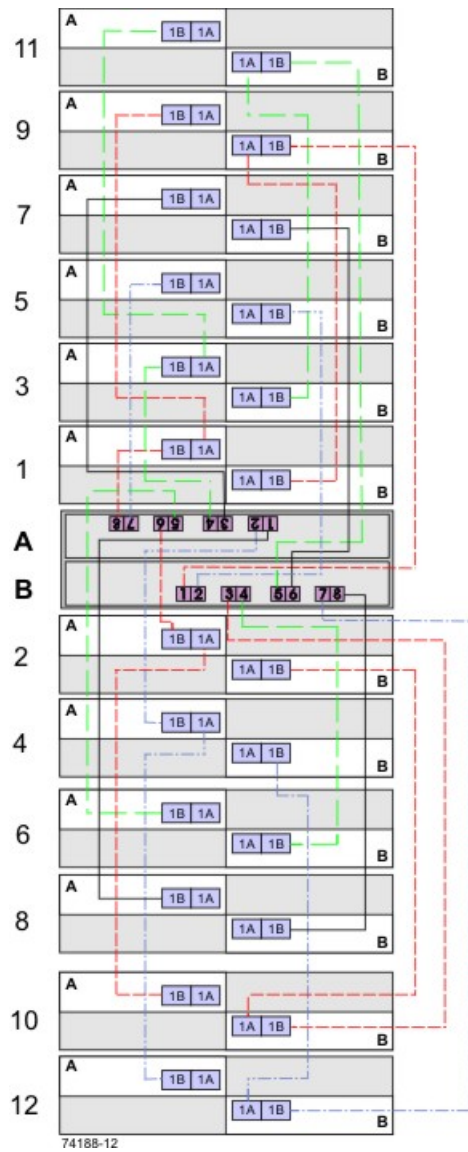

One CE7900 Controller Tray and 14 FC4600 Drive Trays

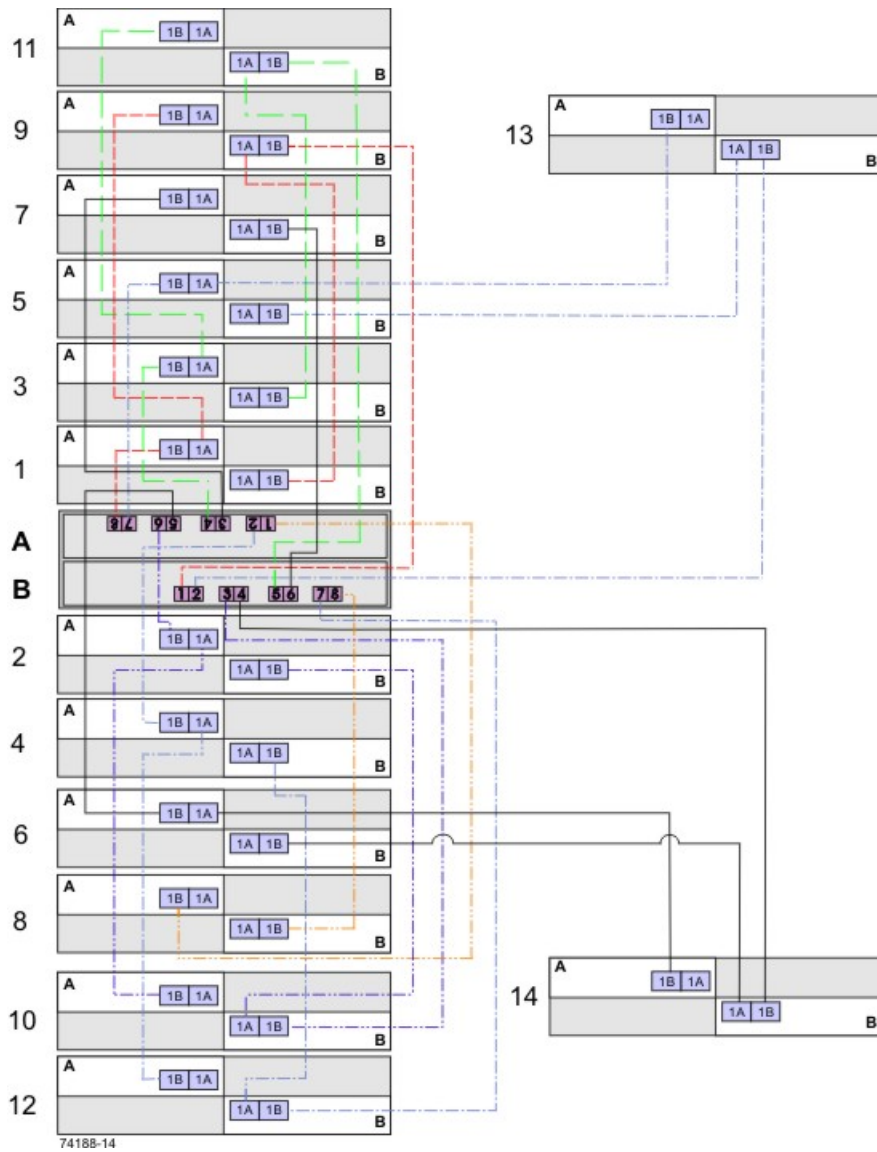

One CE7900 Controller Tray and 16 FC4600 Drive Trays

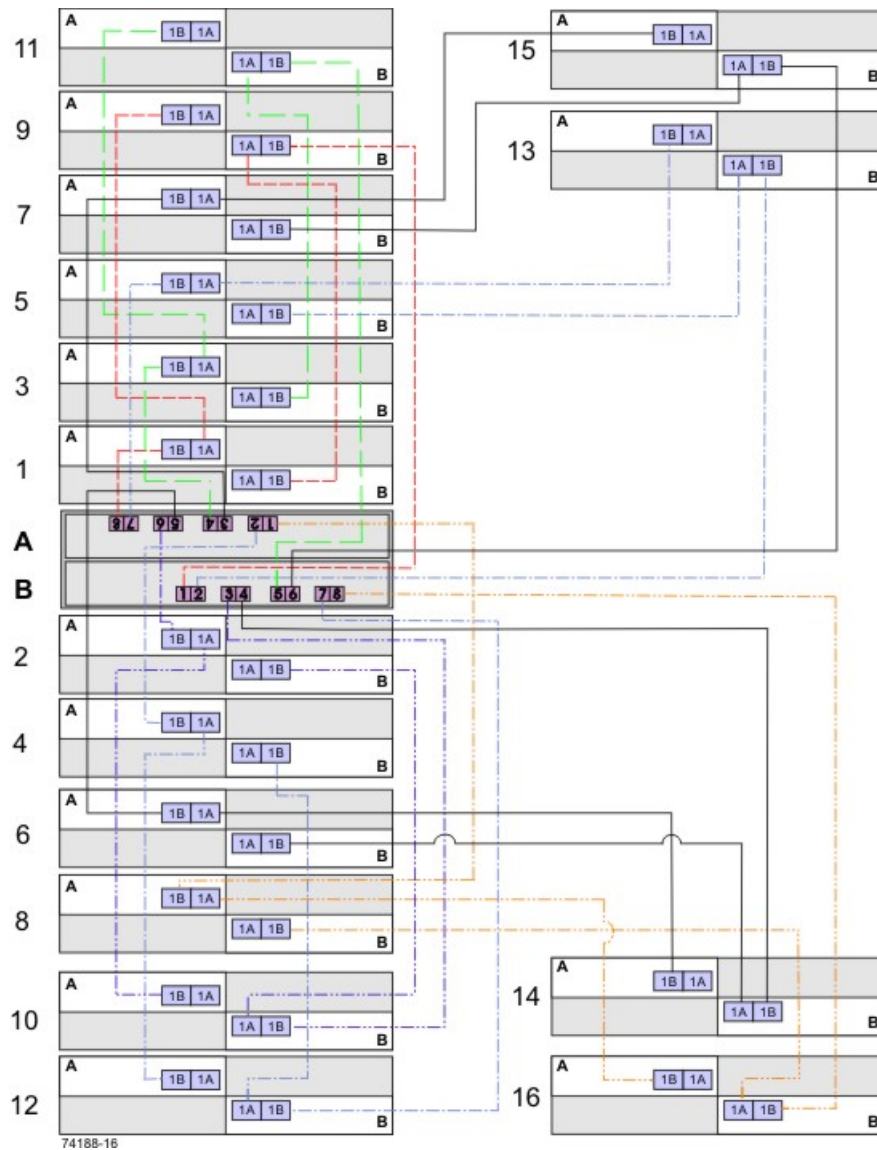

You can add drive trays in series to each redundant pair of drive ports up to 28 drive trays. In a configuration with 28 drive trays, four of the port pairs will have four drive trays each, while the other four will have three drive trays each. [Figure 1-14](#) shows this arrangement schematically. The physical arrangement of the drive trays in cabinets will depend on your particular installation.

One CE7900 Controller Tray and 28 FC4600 Drive Trays

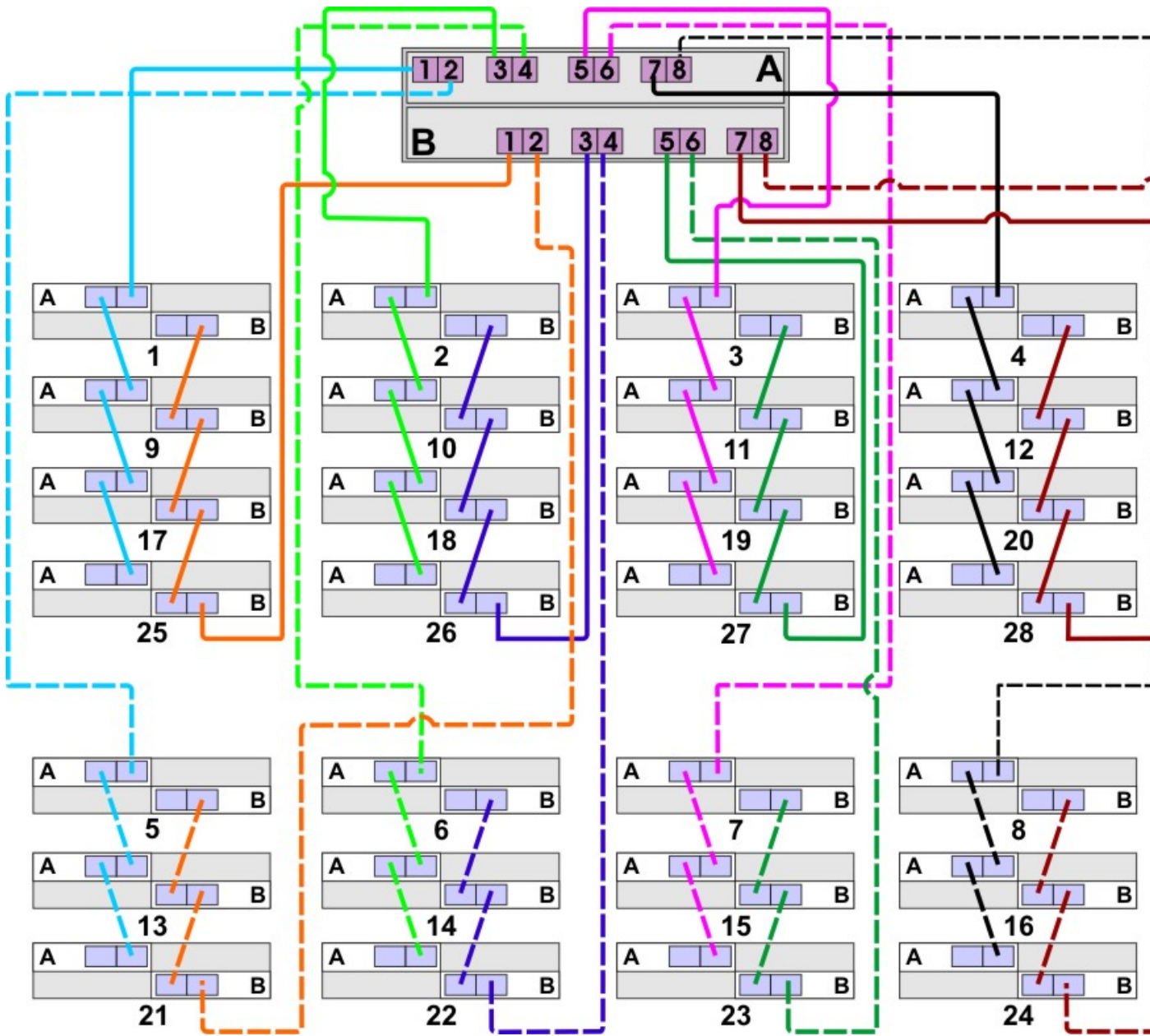

Step 8 – Connecting the Ethernet Cables

Key Terms

in-band management

A method to manage a storage array in which a storage management station sends commands to the storage array through the host input/output (I/O) connection to the controller.

out-of-band management

A method to manage a storage array in which a storage management station sends commands to the storage array through the Ethernet connections on the controller.

Things to Know – Connecting Ethernet Cables



ATTENTION Risk of security breach – Connect the Ethernet ports on the controller tray to a private network segment behind a firewall. If the Ethernet connection is not protected by a firewall, your storage array might be at risk of being accessed from outside of your network.

- These Ethernet connections are intended for out-of-band management and have nothing to do with the iSCSI host interface cards (HICs), whether 1Gb/s or 10Gb/s.
- Ethernet port 2 on each controller is reserved for access by your Customer and Technical Support representative.
- In limited situations in which the storage management station is connected directly to the controller tray, you must use an Ethernet crossover cable. An Ethernet crossover cable is a special cable that reverses the pin contacts between the two ends of the cable.

Procedure – Connecting Ethernet Cables

Perform these steps to connect Ethernet cables for out-of-band management. If you use only in-band management, skip these steps.

1. Connect one end of an Ethernet cable into the Ethernet port 1 on controller A.
2. Connect the other end to the applicable network connection.
3. Repeat step 1 through step 2 for controller B.

Step 9 – Connecting the Power Cords in a CE7900 Controller Tray Configuration

The CE7900 controller tray, the DE6900 drive tray, and the FC4600 drive tray have standard power connections to an AC power source.



IMPORTANT Make sure that you do not turn on the power to the controller tray or the connected drive trays until this documentation instructs you to do so. For the correct procedure for turning on the power, see [“Step 10 – Turning on the Power and Checking for Problems in a CE7900 Controller Tray Configuration.”](#)

Things to Know – AC Power Cords

- For each AC power connector on the drive tray, make sure that you use a separate power source in the cabinet. Connecting to independent power sources maintains power redundancy.
- To ensure proper cooling and assure availability, the drive trays always use two power supplies.
- You can use the power cords shipped with the controller-drive tray with typical outlets used in the destination country, such as a wall receptacle or an uninterruptible power supply (UPS). These power cords, however, are not intended for use in most EIA-compliant cabinets.

Procedure – Connecting AC Power Cords

1. Make sure that the circuit breakers in the cabinet are turned off.
2. Make sure that both of the Power switches on the controller-drive tray are turned off.
3. Connect the primary power cords from the cabinet to the external power source.
4. Connect a cabinet interconnect power cord (or power cords specific to your particular cabinet) to the AC power connector on each power canister in the drive tray.
5. If you are installing other drive trays in the cabinet, connect a power cord to each power canister in the drive trays.

Step 10 – Turning on the Power and Checking for Problems in a CE7900 Controller Tray Configuration

Once you complete this task, you can begin to install the software and perform basic configuration tasks on your storage array. Continue with the *Initial Configuration and Software Installation* in these electronic document topics or through the PDF that is available on the SANtricity ES Storage Manager Installation DVD.

Procedure – Turning on the Power to the Storage Array and Checking for Problems

 **IMPORTANT** You must turn on the power to all of the connected drive trays before you turn on the power for the controller tray. Performing this action makes sure that the controllers recognize each attached drive tray.

 **NOTE** While the power is being applied to the trays, the LEDs on the front and the rear of the trays come on and go off intermittently.

1. Turn on both Power switches on each drive tray that is attached to the controller tray. Depending on your configuration, it can take several minutes for each drive tray to complete the power-on process.









 **IMPORTANT** Before you go to step 2, check the LEDs on the drive tray to verify that the power was successfully applied to all of the drive trays. Wait 30 seconds after turning on the power to the drive tray before turning on the power to the controller tray.



2. Turn on both Power switches on the rear of the controller tray. Depending on your configuration, it can take several minutes for the controller tray to complete the power-on process.
3. Check the LEDs on the front and the rear of the controller tray and the attached drive trays (see [“Things to Know – LEDs on the CE7900 Controller Tray,”](#) [“Things to Know – LEDs on the DE6900 Drive Tray,”](#) and [“Things to Know – LEDs on the FC4600 Drive Tray”](#)).
4. If you see any amber LEDs, make a note of their location.

Things to Know – LEDs on the CE7900 Controller Tray

LEDs on the Controller Tray

| LED | Symbol | Location (Canisters) | Function |
|-------|---|--------------------------------|---|
| Power |  | Power-fan Interconnect-battery | <ul style="list-style-type: none"> ▪ On – The canister has power. ▪ Off – The canister does not have power. <p>NOTE – The controller canisters do not have a Power LED. They receive their power from the power supplies inside the power-fan canisters.</p> |

| LED | Symbol | Location (Canisters) | Function |
|---|---|--|---|
| Battery Needs Attention |  | Interconnect-battery | On – A problem exists with the battery. |
| Service Action Allowed |  | Power-fan Controller Interconnect-battery | On – You can remove the canister safely. See “Things to Know – Service Action Allowed LEDs.” |
| Service Action Required (Fault) |  | Power-fan Controller Interconnect-battery | On – A problem exists with the canister. |
| Locate |  | Interconnect-battery | On – A tray is located. |
| Host Channel Speed (8-Gb/s Fibre Channel Host Interface Card) |  | Controller | The speed of the host channel is indicated: <ul style="list-style-type: none"> ▪ Left LED on – 2 Gb/s ▪ Right LED on – 4 Gb/s ▪ Left LED and right LED on – 8 Gb/s |
| Host Channel Speed (4-Gb/s Fibre Channel Host Interface Card) |  | Controller | The speed of the host channel is indicated: <ul style="list-style-type: none"> ▪ Left LED on – 1 Gb/s ▪ Right LED on – 2 Gb/s ▪ Left LED and right LED on – 4 Gb/s |
| Drive Port Bypass |  | Controller | On – A bypassed port is indicated. |
| Drive Channel Speed |  | Controller | The speed of the drive channel is indicated: <ul style="list-style-type: none"> ▪ Right LED on – 2 Gb/s |

| LED | Symbol | Location (Canisters) | Function |
|--|---|----------------------|---|
| | | | <ul style="list-style-type: none"> Left LED and right LED on – 4 Gb/s |
| Cache Active |  | Controller | <p>The activity of the cache is indicated:</p> <ul style="list-style-type: none"> Blinking – Data is in cache. Off – No data is in cache. |
| Tray ID Numeric Display and Diagnostic Display |  | Controller | <p>The tray ID or a diagnostic code is indicated (see the "Supported Diagnostic Codes" table that follows at the end of this section). For example, if some of the cache memory dual in-line memory modules (DIMMs) are missing in a controller, error code L8 appears in the diagnostic display.</p> |
| Ethernet Speed and Ethernet Activity |  | Controller | <p>The speed of the Ethernet ports and whether a link has been established are indicated:</p> <ul style="list-style-type: none"> Left LED on – 1000BASE-T speed Left LED off – 100BASE-T or 10BASE-T speed Right LED on – A link is established. Right LED off – No link exists. Right LED blinking – Activity is occurring. |

Supported Diagnostic Codes

| Diagnostic Code | Description |
|-----------------|---|
| L0 | The controller types are mismatched. |
| L1 | The interconnect-battery canister is missing. |
| L2 | A persistent memory error has occurred. |
| L3 | A persistent hardware error has occurred. |

| Diagnostic Code | Description |
|-----------------|---|
| L4 | A persistent data protection error has occurred. |
| L5 | The auto-code synchronization (ACS) has failed. |
| L6 | An unsupported host interface card is installed. |
| L7 | The sub-model identifier is not set or is mismatched. |
| L8 | A memory configuration error has occurred. |
| L9 | A link speed mismatch has occurred. |
| LA | Reserved. |
| Lb | Host card configuration error has occurred. |
| LC | Persistent cache backup configuration error has occurred. |
| Ld | Mixed cache memory DIMMs exist. |
| LE | Uncertified cache memory DIMM sizes exist. |
| LF | Lockdown with limited SYMbol support exists exist. |
| LH | Controller firmware mismatch has occurred. |

Things to Know – Service Action Allowed LED

Each controller canister, power-fan canister, and interconnect-battery canister has a Service Action Allowed LED, which is a blue LED. The Service Action Allowed LED lets you know when you can remove a canister safely.

 **ATTENTION Possible loss of data access** – Never remove a controller canister, a power-fan canister, or an interconnect-battery canister unless the Service Action Allowed LED is on.







If a controller canister, a power-fan canister, or a interconnect-battery canister fails and must be replaced, the Service Action Required (Fault) LED (an amber LED) on that canister comes on to indicate that service action is required. The Service Action Allowed LED also comes on if it is safe to remove the canister. If data availability dependencies exist or other conditions that dictate a canister should not be removed, the Service Action Allowed LED stays off.

The Service Action Allowed LED automatically comes on or goes off as conditions change. In most cases, the Service Action Allowed LED comes on when the Service Action Required (Fault) LED comes on for a canister.

 **IMPORTANT** If the Service Action Required (Fault) LED comes on but the Service Action Allowed LED is off for a particular canister, you might need to service another canister first. Check your storage management software to determine the action that you should take.

General Behavior of the LEDs on the Drive Trays

LED Symbols and General Behavior on the Drive Trays

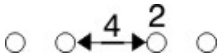
| LED | Symbol | Location | General Behavior |
|---------------------------------|---|---|---|
| Power |  | Drive tray ESM canister Power-fan canister | On – Power is applied to the drive tray or the canister. Off – Power is not applied to the drive tray or the canister. |
| Service Action Allowed |  | ESM canister Power-fan canister Drive | On – It is safe to remove the ESM canister, the power-fan canister, or the drive. Off – Do not remove the ESM canister, the power-fan canister, or the drive. The drive has an LED but no symbol. |
| Service Action Required (Fault) |  | ESM canister Power-fan canister Drive | On – When the drive tray LED is on, a component within the drive tray needs attention. On – The ESM canister, the power-fan canister, or the drive needs attention. Off – The ESM canister, the power-fan canister, and the drive are operating normally. The drive has an LED but no symbol. |
| Locate |  | Front bezel on the drive tray | On or blinking – Indicates the drive tray that you are trying to find. |
| Over-Temperature |  | Front bezel on the DE6900 drive tray | On – The temperature of the drive tray has reached an unsafe condition. Off – The temperature of the drive tray is within operational range. |
| Drive Port Bypass |  | ESM canister | Indicates if a port has been bypassed. |
| Drive Channel Speed |  | ESM canister | Indicates the speed of the drive channel: If the right LED is On -- 2 Gb/s If both LED are Off -- 4 Gb/s |

| LED | Symbol | Location | General Behavior |
|----------|---------|--|---|
| AC Power | AC ~ | ESM canister Power-fan canister Note LED is directly above or below AC Power Switch and AC Power Connectors | On – AC power is present. Off – AC power is not present. |
| DC Power | DC — | Power-fan canister | Indicates the power supply is outputting DC power |

Service Action LEDs on the Drive Tray

 **ATTENTION Possible loss of data access** – Never remove any canister unless the appropriate Service Action Allowed LED is turned on.

Each canister in the drive tray has two service action LEDs.

- **Service Action Required LED** – This LED comes on to indicate that a condition exists that requires service.
- **Service Action Allowed LED** – This LED comes on when it is safe to remove a failed canister. If data availability dependencies or other conditions exist that dictate that a canister should not be removed, the Service Action Allowed LED stays off. The Service Action Allowed LED automatically comes on or goes off as conditions change.

 **IMPORTANT** If the Service Action Required LED is on but the Service Action Allowed LED is off for a particular canister, you might need to service another canister first. Check your storage management software to determine the action that you should take.

 **NOTE** In most cases, the Service Action Allowed LED comes on when the Service Action Required LED is on for a canister.

Things to Know – LEDs on the DE6900 Drive Tray

The following topics describe the LEDs that are available on DE6900 drive tray.

LEDs on the DE6900 Drive Tray

LEDs on the DE6900 Left End Cap

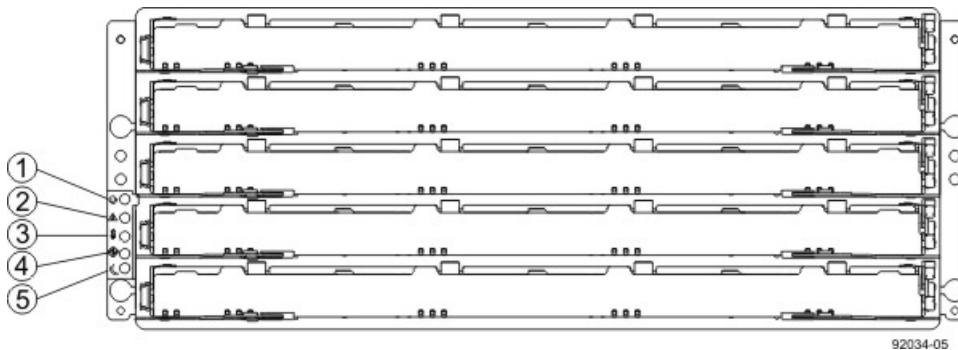

1. Drive Tray Locate LED
2. Drive Tray Service Action Required LED
3. Drive Tray Over-Temperature LED
4. Power LED
5. Standby Power

LEDs on the DE6900 Left End Cap

| Location | LED | Color | On | Off |
|----------|-----------------------------|-------|--|--|
| 1 | Drive Tray Locate | White | Identifies a drive tray that you are trying to find. | Normal status. |
| 2 | Service Action Required | Amber | A component within the drive tray needs attention. | Normal status. |
| 3 | Drive Tray Over-Temperature | Amber | The temperature of the drive tray has reached an unsafe level. | Normal status. |
| 4 | Power | Green | Power is present. | Power is not present. |
| 5 | Standby | Green | The drive tray is in Standby mode. | The drive tray is not in Standby mode. |

LEDs on the DE6900 ESM Canister

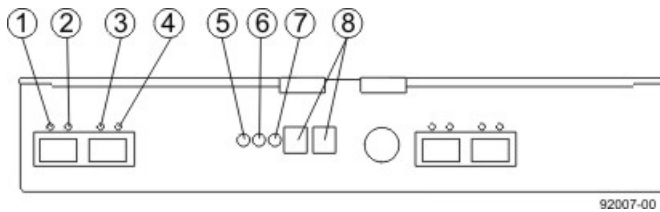

1. ESM Link Fault LED (Port 1A Bypass)
2. ESM Link LED (Port 1A Data Rate)
3. ESM Link LED (Port 1B Data Rate)
4. ESM Link Fault LED (Port 1B Bypass)
5. ESM Service Action Allowed LED
6. ESM Service Action Required LED
7. ESM Power LED
8. Seven-Segment Tray ID

LEDs on the DE6900 ESM Canister

| Location | LED | Color | On | Off |
|----------|---------------------------------|-------|--|---|
| 1 | ESM Link Fault (Port 1A Bypass) | Amber | A link error has occurred. | No link error has occurred. |
| 2 | ESM Link (Port 1A) | Green | The link is up. | A link error has occurred. |
| 3 | ESM Link (Port 1B Bypass) | Green | The link is up. | A link error has occurred. |
| 4 | ESM Link Fault (Port 1B) | Amber | A link error has occurred. | No link error has occurred. |
| 5 | ESM Service Action Allowed | Blue | The ESM can be removed safely from the drive tray. | The ESM cannot be removed safely from the drive tray. |
| 6 | ESM Service Action Required | Amber | A fault exists within the ESM. | Normal status. |
| 7 | ESM Power | Green | Power to the ESM is present. | Power is not present to the ESM. |
| 8 | Seven-Segment Tray ID | Green | For more information, see "Supported Diagnostic Codes on the Seven-Segment Display". | Not applicable. |

LEDs on the DE6900 Power Canister

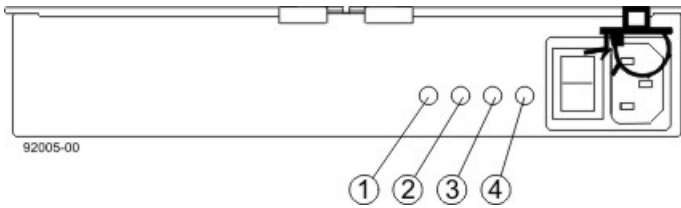

- 1. Power DC Power LED
- 2. Power Service Action Allowed LED
- 3. Power Service Action Required LED
- 4. Power AC Power LED

LEDs on the DE6900 Power Canister

| Location | LED | Color | On | Off |
|----------|-------------------------------|-------|---|--|
| 1 | Power DC Power | Green | DC power from the power canister is available. | DC power from the power canister is not available. |
| 2 | Power Service Action Allowed | Blue | The power canister can be removed safely from the drive tray. | The power canister cannot be removed safely from the drive tray. |
| 3 | Power Service Action Required | Amber | A fault exists within the power canister. | Normal status. |
| 4 | Power AC Power | Green | AC power to the power canister is present. | AC power to the power canister is not present. |

LEDs on the DE6900 Fan Canister

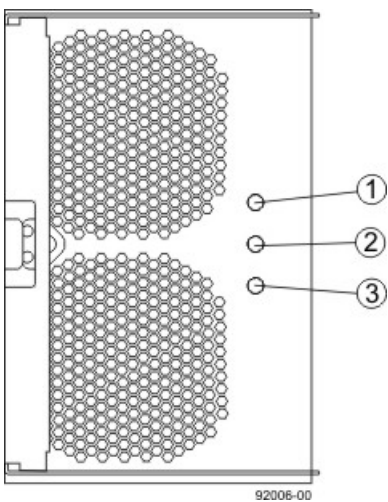

- 1. Power LED
- 2. Fan Service Action Required LED
- 3. Fan Service Action Allowed LED

LEDs on the DE6900 Fan Canister

| Location | LED | Color | On | Off |
|----------|-----------------------------|-------|---|--|
| 1 | Power | Green | Power from the fan canister is available. | Power to the fan customer-replaceable unit (CRU) is available. |
| 2 | Fan Service Action Required | Amber | A fault exists within the fan canister. | Normal status. |
| 3 | Fan Service Action Allowed | Blue | The fan canister can be removed safely from the drive tray. | The fan canister cannot be removed safely from the drive tray. |

LEDs on the Drive Drawers

LEDs on the Drawer

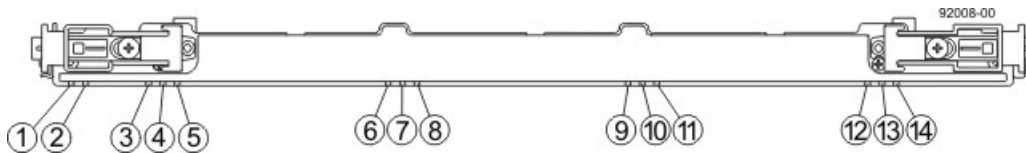

1. Drive Drawer Service Action Required LED
2. Drive Drawer Service Action Allowed LED
3. Drive 1 Activity LED
4. Drive 2 Activity LED
5. Drive 3 Activity LED
6. Drive 4 Activity LED
7. Drive 5 Activity LED
8. Drive 6 Activity LED
9. Drive 7 Activity LED
10. Drive 8 Activity LED
11. Drive 9 Activity LED
12. Drive 10 Activity LED
13. Drive 11 Activity LED
14. Drive 12 Activity LED

LEDs on the Drawer

| Location | LED | Color | On | Blinking | Off |
|----------|--------------------------------------|-------|---|----------|--|
| 1 | Drive Drawer Service Action Required | Amber | An error has occurred. | | Normal status. |
| 2 | Drive Drawer Service Action Allowed | Blue | The drive canister can be removed safely from the drive drawer in the drive tray. | | The drive canister cannot be removed safely from the drive drawer in the drive tray. |

| Location | LED | Color | On | Blinking | Off |
|----------|--|-------|--|-------------------------------------|--------------------------|
| 3–14 | Drive Activity for drives 1 through 12 in the drive drawer | Green | The power is turned on, and the drive is operating normally. | Drive I/O activity is taking place. | The power is turned off. |

Drive State Represented by the LEDs

| Drive State | Drive Activity LED (Green) | Drive Service Action Required LED (Amber) |
|---|----------------------------|---|
| Power is not applied. | Off | Off |
| Normal operation – The power is turned on, but drive I/O activity is not occurring. | On | Off |
| Normal operation – Drive I/O activity is occurring. | Blinking | Off |
| Service action required – A fault condition exists, and the drive is offline. | On | On |

LEDs on the DE6900 Drives

LEDs on the DE6900 Drive



1. Drive Service Action Allowed LED
2. Drive Service Action Required LED

LEDs on the Drives

| Location | LED | Color | On | Off |
|----------|------------------------------|-------|--|--------------------------------------|
| 1 | Drive Service Action Allowed | Blue | The drive canister can be removed safely | The drive canister cannot be removed |

| Location | LED | Color | On | Off |
|----------|-------------------------------|-------|--|---|
| | | | from the drive drawer in the drive tray. | safely from the drive drawer in the drive tray. |
| 2 | Drive Service Action Required | Amber | An error has occurred. | Normal status. |

Things to Know – LEDs on the FC4600 Drive Tray

The following topics describe the LEDs that are available on FC4600 drive tray.

LEDs on the FC4600 Drive Tray

LEDs on the FC4600 – Front View

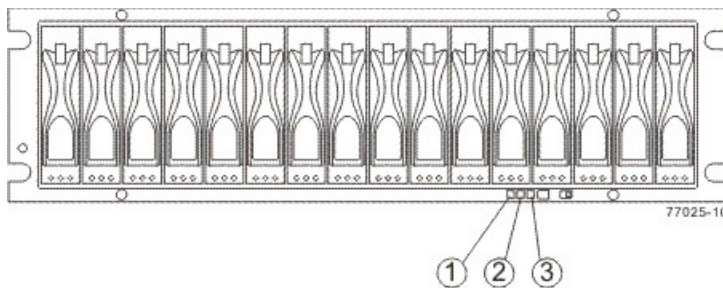

1. Drive Tray Locate LED
2. Drive Tray Service Action Required LED
3. Power LED

LEDs on the FC4600 Left End Cap

| Location | LED | Color | On | Off |
|----------|-------------------------|-------|--|-----------------------|
| 1 | Drive Tray Locate | White | Identifies a drive tray that you are trying to find. | Normal status. |
| 2 | Service Action Required | Amber | A component within the drive tray needs attention. | Normal status. |
| 3 | Power | Green | Power is present. | Power is not present. |

LEDs on the FC4600 ESM Canister

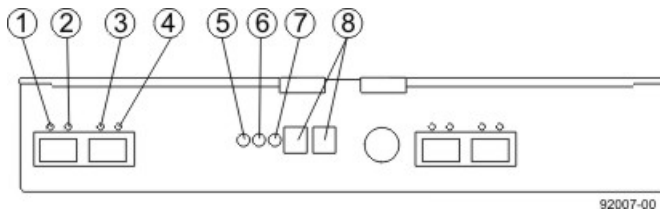

1. ESM Link Fault LED (Port 1A Bypass)
2. ESM Link LED (Port 1A Data Rate)
3. ESM Link LED (Port 1B Data Rate)
4. ESM Link Fault LED (Port 1B Bypass)
5. ESM Service Action Allowed LED
6. ESM Service Action Required LED
7. ESM Power LED
8. Seven-Segment Tray ID

LEDs on the FC4600 ESM Canister

| Location | LED | Color | On | Off |
|----------|---------------------------------|-------|--|---|
| 1 | ESM Link Fault (Port 1A Bypass) | Amber | A link error has occurred. | No link error has occurred. |
| 2 | ESM Link (Port 1A) | Green | The link is up. | A link error has occurred. |
| 3 | ESM Link (Port 1B Bypass) | Green | The link is up. | A link error has occurred. |
| 4 | ESM Link Fault (Port 1B) | Amber | A link error has occurred. | No link error has occurred. |
| 5 | ESM Service Action Allowed | Blue | The ESM can be removed safely from the drive tray. | The ESM cannot be removed safely from the drive tray. |
| 6 | ESM Service Action Required | Amber | A fault exists within the ESM. | Normal status. |
| 7 | ESM Power | Green | Power to the ESM is present. | Power is not present to the ESM. |
| 8 | Seven-Segment Tray ID | Green | For more information, see "Supported Diagnostic Codes on the Seven-Segment Display". | Not applicable. |

LEDs on the FC4600 Power Canister

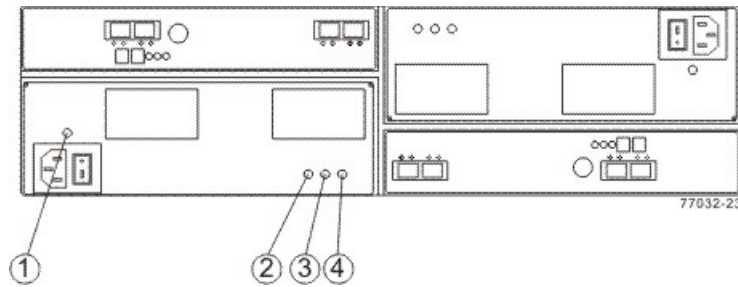

1. Power AC Power LED
2. Power Service Action Allowed LED
3. Power Service Action Required LED
4. Power DC Power LED

LEDs on the FC4600 Power Canister

| Location | LED | Color | On | Off |
|----------|-------------------------------|-------|---|--|
| 1 | Power AC Power | Green | AC power to the power canister is present. | AC power to the power canister is not present. |
| 2 | Power Service Action Allowed | Blue | The power canister can be removed safely from the drive tray. | The power canister cannot be removed safely from the drive tray. |
| 3 | Power Service Action Required | Amber | A fault exists within the power canister. | Normal status. |
| 4 | Power DC Power | Green | DC power from the power canister is available. | DC power from the power canister is not available. |

LEDs on the FC4600 Drives

LEDs on the FC4600 Drive

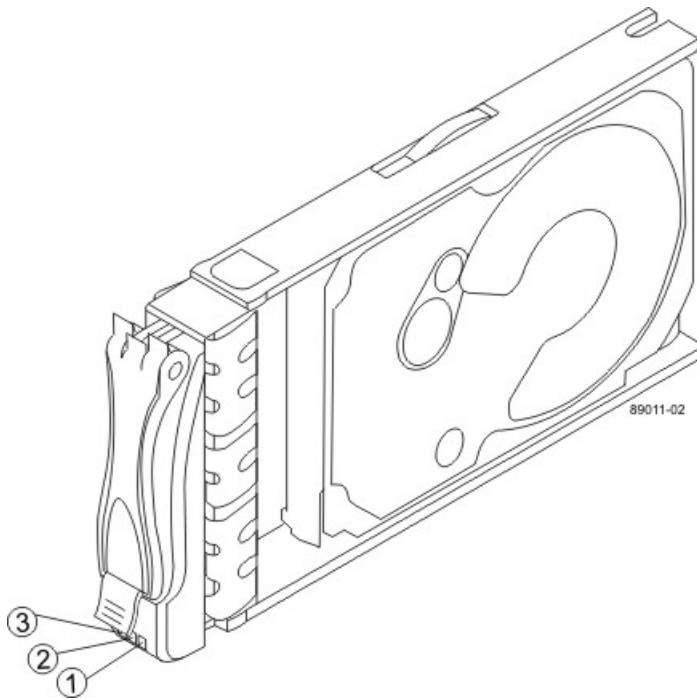

1. Drive Power LED
2. Drive Service Action Required LED
3. Drive Service Action Required LED

LEDs on the Drives

| Location | LED | Color | On | Blinking | Off |
|----------|-------------------------------|-------|---|----------------------------|--|
| 1 | Drive Power | Green | The power is turned on, and the drive is operating normally. | Drive I/O is taking place. | The power is turned off. |
| 2 | Drive Service Action Required | Amber | An error has occurred. | | Normal status. |
| 3 | Drive Service Action Allowed | Blue | The drive canister can be removed safely from the drive tray. | | The drive canister cannot be removed safely from the drive tray. |

Supported Diagnostic Codes on the Seven-Segment Display for the DE6900 Drive Tray and the FC4600 Drive Tray

The following table provides the diagnostic that can appear on the both the FC4600 drive tray and the DE6900 drive tray.



NOTE The diagnostic codes concerning drive-side trunking only apply to the DE6900 drive tray.

Supported Diagnostic Codes

| Diagnostic Code | Description |
|-----------------|--|
| -- | The firmware is booting. |
| .8, 8., or 88 | This ESM is being held in reset by another ESM. |
| AA | ESM A firmware is in the process of booting (the diagnostic indicator is not yet set). |
| bb | ESM B firmware is in the process of booting (the diagnostic indicator is not yet set). |
| L0 | The controller types are mismatched. |
| L2 | A persistent memory error has occurred. |
| L3 | A persistent hardware error has occurred. |
| L9 | An over-temperature condition has been detected in either the ESM or the power supply. |
| H0 | An ESM Fibre Channel interface failure has occurred. |
| H1 | An SFP transceiver speed mismatch (a 2-Gb/s SFP transceiver is installed when the drive tray is operating at 4 Gb/s) indicates that an SFP transceiver must be replaced. Look for the SFP transceiver with a blinking amber LED. |
| H2 | The ESM configuration is invalid or incomplete or is operating in a Degraded state. |
| H3 | The maximum number of ESM reboot attempts has been exceeded. |
| H4 | This ESM cannot communicate with the alternate ESM. |
| H5 | A midplane harness failure has been detected in the drive tray. |
| H6 | A catastrophic ESM hardware failure has been detected. |
| H8 | SFP transceivers are present in currently unsupported ESM slots, either 2A or 2B. Secondary trunking SFP transceiver slots 2A and 2B are not supported. Look for the SFP transceiver with the blinking amber LED, and remove it. |
| H9 | A non-catastrophic hardware failure has occurred. The ESM is operating in a Degraded state. |
| J0 | The ESM canister is incompatible with the drive tray firmware. |

| Diagnostic Code | Description |
|-----------------|--|
| J1 | <p>The drive-side trunk links are connected to two different components, and both links are not operational. Examine both links indicated by the blinking LEDs, and re-cable the links to match the drive-side trunking cabling diagrams.</p> |
| J2 | <p>An error has occurred. A cross-connected trunk port pair is the result of one of these three situations:</p> <ul style="list-style-type: none"> ▪ A trunk pair from the local component is not connected to a trunked pair of SFP ports on the remote component. ▪ A trunk pair from the remote component is not connected to a trunked pair of SFP ports on the local component. ▪ Both the local connections and the remote connections for an interconnecting pair of links are not connected to trunked pairs of SFP ports. <p>Examine both links indicated by the blinking LEDs, and re-cable the links to match the existing drive-side trunking diagrams.</p> |
| J3 | <p>An error has occurred. Three or more links are connected from one component to another. No more than two links are supported from one component to another. Examine all links indicated by the blinking LEDs, and re-cable the links to match the existing drive-side trunking diagrams.</p> |
| J4 | <p>The trunk pair Primary and Dup swapped. Both links indicated by the blinking bypass LEDs are operational, but their cabling connections must be switched on either the local component end or the remote component end.</p> |
| J5 | <p>The trunk pair is operational, but it is cabled incorrectly. At least one Out link is connected to the In link, or one In link is connected to an Out link. Both links indicated by the blinking bypass LEDs are operational, but they must be re-cabled on one end so that the Primary Out is connected to Primary In, and Dup Out is connected to Dup In.</p> |

CDE4900 Controller-Drive Tray Installation

This topic provides basic information for installing the CDE4900 controller-drive tray and the FC4600 drive tray in a storage array. After you have completed these tasks, you will continue onto the *Initial Configuration and Software Installation* electronic document topics or the PDF on the SANtricity ES Storage Manager Installation DVD.

Step 1 – Preparing for an Installation

The CDE4900 storage array consists of a CDE4900 controller-drive tray and one or more FC4600 drive trays in a cabinet. This document includes instructions for installing the FC4600 drive trays.



ATTENTION Possible hardware damage – To prevent electrostatic discharge damage to the tray, use proper antistatic protection when handling tray components.

Key Terms

storage array

A collection of both physical components and logical components for storing data. Physical components include drives, controllers, fans, and power supplies. Logical components include volume groups and volumes. These components are managed by the storage management software.

Also known as RAID tray.

controller-drive tray

One tray with drives, one or two controllers, fans, and power supplies. The controller-drive tray provides the interface between a host and a storage array.

See also , drive tray, storage array.

controller

A circuit board and firmware that is located within a controller tray or a controller-drive tray. A controller manages the input/output (I/O) between the host system and data volumes.

drive tray

One tray with drives, one or two environmental services monitors (ESMs), power supplies, and fans. A drive tray does not contain controllers.

See also controller-drive tray, .

environmental services monitor (ESM)

A canister in the drive tray that monitors the status of the components. An ESM also serves as the connection point to transfer data between the drive tray and the controller.

Small Form-factor Pluggable (SFP) transceiver

A component that enables Fibre Channel duplex communication between storage array devices. SFP transceivers can be inserted into host bus adapters (HBAs), controllers, and environmental services monitors (ESMs). SFP transceivers can support either copper cables (the SFP transceiver is integrated with the cable) or fiber-optic cables (the SFP transceiver is a separate component from the fiber-optic cable).



Gathering Items

Before you start installing the controller-drive tray, you must have installed the cabinet in which the controller-drive tray will be mounted.

Use the tables in this section to verify that you have all of the necessary items to install the controller-drive tray.

Basic Hardware

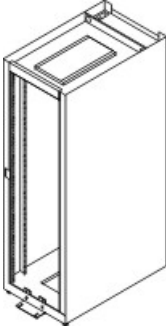
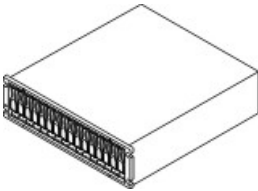
Basic Hardware

| | Item | Included with the Controller-Drive Tray |
|---|---|---|
|  | <p>Cabinet</p> <ul style="list-style-type: none"> Make sure that your cabinet meets the installation site specifications of the various CDE4900 storage array components. Refer to the <i>Storage System Site Preparation Guide</i> on the SANtricity ES Storage Manager Installation DVD for more information. Depending on the power supply limitations of your cabinet, you might need to install more than one cabinet to accommodate the different components of the CDE4900 storage array. Refer to the installation guide for your cabinet for instructions on installing the cabinet. | |
|  | FC4600 drive tray with end caps that are packaged separately. | ✓ |
|  | Mounting rails and screws | ✓ |
| | Fibre Channel switch (optional) | |
| | iSCSI switch (optional) | |
| | Host with Fibre Channel or iSCSI host bus adapters (HBAs) | |

Cables and Connectors on the CDE4900 Controller-Drive Tray Configuration

Cables and Connectors

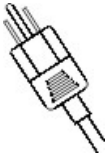
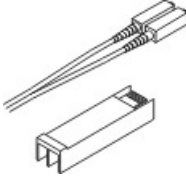
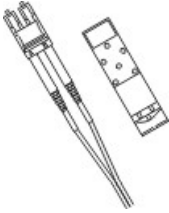
| | Item | Included with the Controller-Drive Tray |
|---|--|---|
|  | <p>AC power cords</p> <p>The controller-drive tray ships with power cords for connecting to an external power source, such as a wall plug. Your cabinet might have special power cords that you use instead of the power cords that ship with the controller-drive tray.</p> | ✓ |
| | <p>DC power connector cables (optional)</p> <p>With the DC power option, the controller-drive tray ships with two or four DC power connector cables (depending on the requirements for redundancy). You use the DC power connector cables to connect to a DC power source.</p> <p>NOTE – A two-pole 20-amp circuit breaker is required between the DC power source and the controller-drive tray.</p> | ✓ Included only with the DC power option |
|  | <p>Fiber-optic cables</p> <p>Use these cables for connections to the hosts and within the storage array.</p> <p>For the differences between the fiber-optic cables and the copper Fibre Channel (FC) cables, see the "Step 1 – Deciding on the Management Method" topic from <i>Storage Array Installation and Initial Configuration for SANtricity ES Storage Manager Version 10.75</i>, in either the online documentation or from the SANtricity ES Storage Manager Installation DVD.</p> | |
|  | <p>Small Form-factor Pluggable (SFP) transceivers</p> <ul style="list-style-type: none"> ▪ The SFP transceivers connect fiber-optic cables to host ports and drive ports. ▪ Four or eight SFP transceivers are included with the controller-drive tray; one for each of the host channel ports on the controllers. ▪ Depending on your connection requirements, you might need to purchase additional SFP transceivers (two SFP transceivers for each fiber-optic cable). ▪ Depending on the configuration of your storage array, you might need to use various combinations of four different types of SFP transceivers: 8-Gb/s Fibre Channel, 4-Gb/s | ✓ |

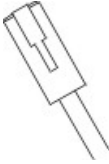
| | Item | Included with the Controller-Drive Tray |
|--|---|---|
| | <p>Fibre Channel, 10-Gb/s iSCSI, or 1-Gb/s iSCSI. These SFP transceivers are not generally interchangeable.</p> <ul style="list-style-type: none"> You must purchase <i>only</i> Restriction of Hazardous Substances (RoHS)-compliant SFP transceivers. | |
| | <p>Copper Fibre Channel cables (optional) Use these cables for connections within the storage array. For the differences between the fiber-optic cables and the copper Fibre Channel cables, see Things to Know – SFP Transceivers, Fiber-Optic Cables, Copper Cables, and SAS Cables.</p> | |
|  | <p>Ethernet cable This cable is used for out-of-band storage array management and for 1-Gb/s iSCSI connections. For information about out-of-band storage array management, see the "Step 1 – Deciding on the Management Method" topic from <i>Storage Array Installation and Initial Configuration for SANtricity ES Storage Manager Version 10.75</i>, in either the online documentation or from the SANtricity ES Storage Manager Installation DVD.</p> | |

Product DVDs

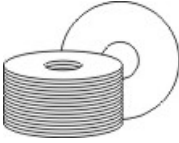

Product DVDs

| | Item | Included with the Controller-Drive Tray |
|---|---|---|
|  | <p>Firmware DVD</p> <ul style="list-style-type: none"> Firmware is already installed on the controllers. The files on the DVD are backup copies. <p>SANtricity ES Storage Manager Installation DVD</p> <ul style="list-style-type: none"> SANtricity ES Storage Manager software and documentation. To access product documentation, use the documentation map file, <code>doc_launcher.html</code>, which is located in the <code>docs</code> directory. | ✓ |

Tools and Other Items

Tools and Other Items

| | Item | Included with the Tray |
|---|--|------------------------|
| | <p>Labels</p> <p>Help you to identify cable connections and lets you more easily trace cables from one tray to another</p> | |
| | <p>A cart</p> <p>Holds the tray and components</p> | |
| | <p>A mechanical lift (optional)</p> | |
|  | <p>A Phillips screwdriver</p> | |

| | Item | Included with the Tray |
|--|--------------------------|------------------------|
|  | A flat-blade screwdriver | |
|  | Anti-static protection | |
| | A flashlight | |
| <p>Use the Compatibility Matrix, at the following website, to obtain the latest hardware compatibility information. http://www.lsi.com/compatibilitymatrix/</p> | | |

Things to Know – SFP Transceivers, Fiber-Optic Cables, Copper Cables, and SAS Cables

The figures in this topic display the fiber-optic, copper cables, and SFP transceivers.



NOTE Your SFP transceivers and cables might look slightly different from the ones shown. The differences do not affect the performance of the SFP transceivers.

The controller-drive tray supports SAS, Fibre Channel (FC), and iSCSI host connections and SAS drive connections. FC host connections might operate at 8 Gb/s or at a lower data rate. Ports for 8-Gb/s Fibre Channel host connections require SFP transceivers designed for this data rate. These SFP transceivers look similar to other SFP transceivers but are not compatible with other types of connections. SFP transceivers for 1-Gb/s iSCSI connections and 10-Gb/s iSCSI connections have a different physical interface for the cable and are not compatible with other types of connections.



WARNING (W03) Risk of exposure to laser radiation – Do not disassemble or remove any part of a Small Form-factor Pluggable (SFP) transceiver because you might be exposed to laser radiation.

Fiber-Optic Cable Connection

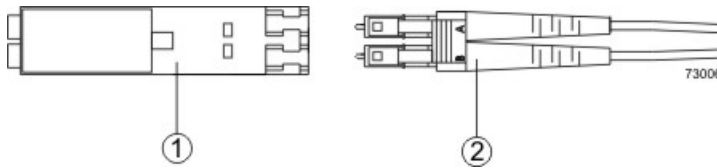

1. Active SFP Transceiver
2. Fiber-Optic Cable

1-Gb/s iSCSI Cable Connection

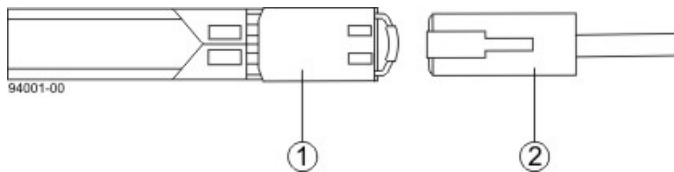

1. Active SFP Transceiver
2. Copper Cable with RJ-45 Connector

Copper Fibre Channel Cable Connection

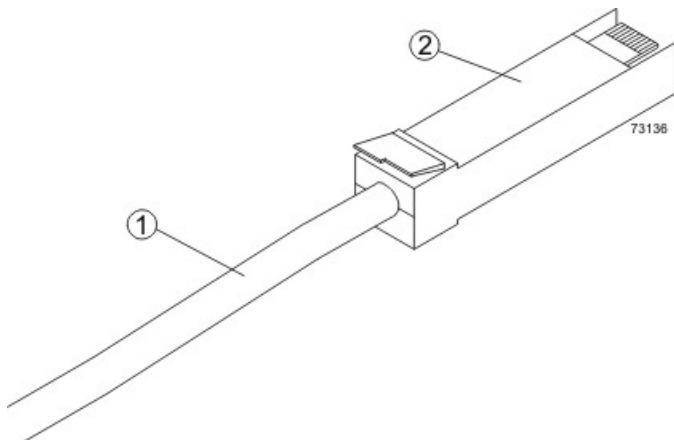

1. Copper Fibre Channel Cable
2. Passive SFP Transceiver

Things to Know – Taking a Quick Glance at the Hardware

For the CDE4900 controller-drive tray:

- The top controller, controller A, is inverted from the bottom controller, controller B.
- The top of the controller-drive tray is the side with labels.
- The configuration of the host ports might appear different on your system depending on which host interface card configuration is installed.

CDE4900 Controller-Drive Tray – Front View and Rear View

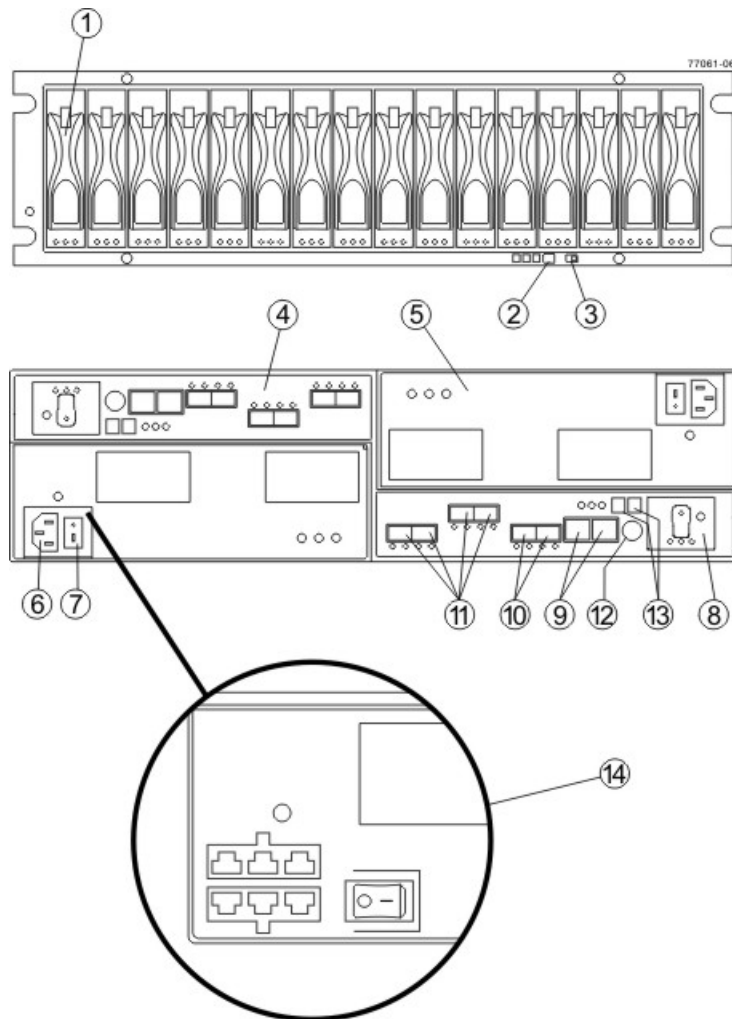



1. (Front View) Drive Canister
2. Alarm Mute Switch
3. Link Rate Switch
4. Controller A (Inverted)
5. Power-Fan Canister
6. AC Power Connector
7. AC Power Switch
8. Battery Canister
9. Ethernet Ports
10. Drive Channels
11. Host Channels
12. Serial Port
13. Seven-Segment Display
14. Optional DC Power Connector and DC Power Switch

For the FC4600 drive tray:

- The top-left ESM is inverted from the bottom-right ESM.
- The top-right power-fan canister is inverted from the bottom-left power-fan canister.
- The drive tray is in the correct (top) orientation when the lights of the drives are at the bottom (Figure

 **NOTE** The drive tray is available in rackmount models and desktside models. The components for the desktside model are identical to the components of the rackmount model. The desktside model is situated as if the rackmount model is sitting on its left side.

 **NOTE** You must use the current drive canisters in the drive tray to ensure proper performance. Using older or “legacy” drives might damage the connectors. Additionally, the latch might not hold the drive in place, which causes the drive to be disconnected and taken offline. For more information on supported drives, contact a Customer and Technical Support representative.

 **WARNING (W14) Risk of bodily injury** – A qualified service person is required to make the DC power connection according to NEC and CEC guidelines.

 **CAUTION (C05) Electrical grounding hazard** – This equipment is designed to permit the connection of the DC supply circuit to the earthing conductor at the equipment.

 **ATTENTION Risk of equipment malfunction** – To avoid exceeding the functional and environmental limits, install only drives that have been provided or approved by the original manufacturer. Drives might be shipped but not installed. System integrators, resellers, system administrators, or users can install the drives.

 **IMPORTANT** Each tray in the storage array must have a minimum of two drives for proper operation. If the tray has fewer than two drives, a power supply error is reported.

FC4600 Drive Tray – Front View and Rear View

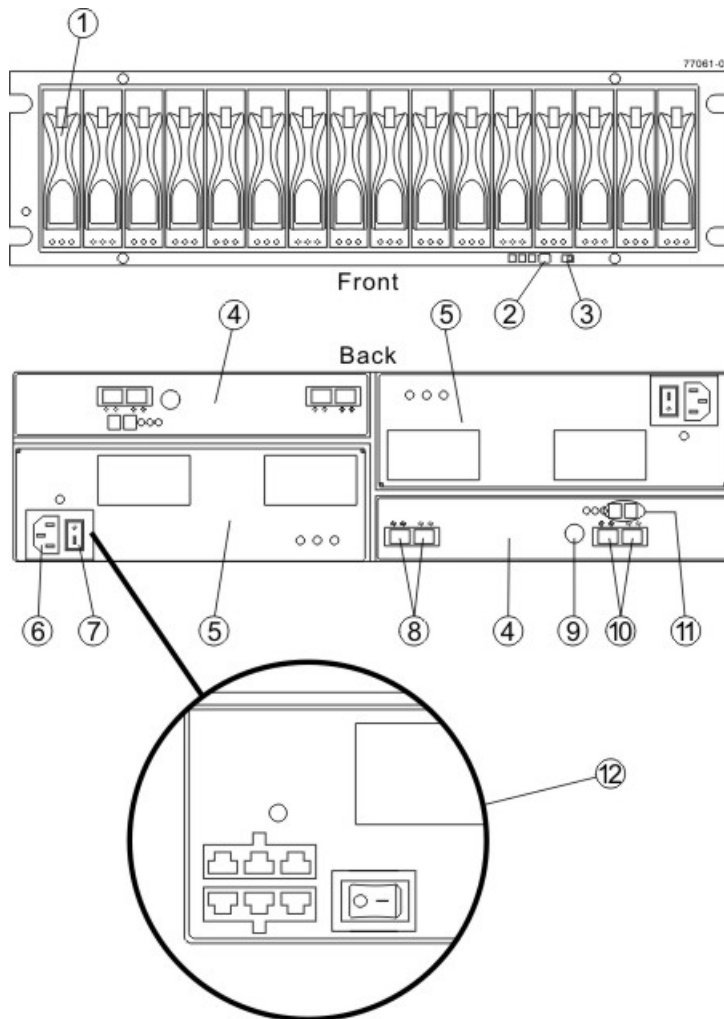

1. Drive Canister
2. Alarm Mute Button
3. Link (Data) Rate Switch (4 Gb/s or 2 Gb/s)
4. ESM Canister
5. Power-Fan Canister
6. AC Power Connector
7. AC Power Switch
8. In/Out Ports
9. Serial Port
10. In/Out Ports (Reserved for future use)
11. Tray ID / Seven-Segment Diagnostic Display
12. (Optional) DC Power Connectors and DC Power Switch

⚠ ATTENTION Possible equipment damage – You must use the drives in the drive tray to ensure proper performance. Using older or “legacy” drives might damage the connectors. Additionally, the latch might not hold the drive in place, which causes the drive to be disconnected and taken offline. For information on supported drives, contact a Customer and Technical Support representative.

⚠ ATTENTION Risk of equipment malfunction – To avoid exceeding the functional and environmental limits, install only drives that have been provided or approved by the original manufacturer. Not all controller-drive trays are shipped with pre-populated drives. System integrators, resellers, system administrators, or users of the controller-drive tray can install the drives.

The following warning applies if you have the DC power option for the controller-drive tray.

⚠ WARNING (W12) Risk of electrical shock – This unit has more than one power source. To remove all power from the unit, all DC MAINS must be disconnected by removing all power connectors (item 4 below) from the power supplies.

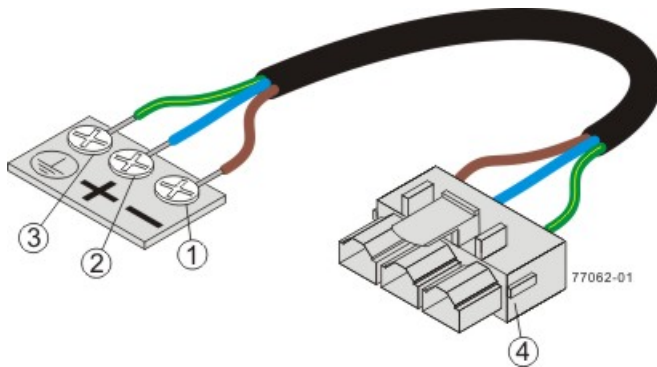

1. Supply (Negative), Brown Wire, -48 VDC
2. Return (Positive), Blue Wire
3. Ground, Green/Yellow Wire
4. DC Power Connector

For Additional Information

Refer to the *Storage System Site Preparation Guide* on the SANtricity ES Storage Manager Installation DVD for information about the installation requirements of the various CDE4900 storage array components.

Step 2 – Installing and Configuring the Switches

Things to Know – Switches



IMPORTANT Most of the switches, as shipped from the vendor, require an update to their firmware to work correctly with the storage array.

Depending on the configuration of your storage array, you might use Fibre Channel switches and iSCSI switches.

The switches in the following table are certified for use with a CDE2600 storage array, a CDE2600-60 storage array, a CDE4900 storage array, and a CE7900 storage array, which all use SANtricity ES Storage Manager Version 10.77.

Supported Switches

| Vendor | Model | Fibre Channel | iSCSI | SAS |
|---------|-------|---------------|-------|-----|
| Brocade | 200E | Yes | No | No |
| | 3200 | Yes | No | No |
| | 3800 | Yes | No | No |
| | 3900 | Yes | No | No |
| | 3950 | Yes | No | No |
| | 12000 | Yes | No | No |
| | 3850 | Yes | No | No |
| | 3250 | Yes | No | No |
| | 24000 | Yes | No | No |
| | 4100 | Yes | No | No |
| | 48000 | Yes | No | No |
| | 5000 | Yes | No | No |
| | 300 | Yes | No | No |
| | 5100 | Yes | No | No |
| | 5300 | Yes | No | No |
| | 7500 | Yes | No | No |
| | 7800 | Yes | No | No |
| DCX | Yes | No | No | |

| Vendor | Model | Fibre Channel | iSCSI | SAS |
|--------|---------------------|---------------|-------|-----|
| | FCOE | No | Yes | No |
| Cisco | 9506 | Yes | No | No |
| | 9509 | Yes | No | No |
| | 9216 | Yes | No | No |
| | 9216i | Yes | No | No |
| | 9120 | Yes | No | No |
| | 914x | Yes | No | No |
| | 9513 | Yes | No | No |
| | 9020 | Yes | No | No |
| | MDS9000 | Yes | No | No |
| | 9222i | Yes | No | No |
| | 9134 | Yes | No | No |
| | Catalyst 2960 | No | Yes | No |
| | Catalyst 3560 | No | Yes | No |
| | Catalyst 3750G-24TS | No | Yes | No |
| LSI | 6160 | No | No | Yes |
| McData | 3232 | Yes | No | No |
| | 3216 | Yes | No | No |
| | 4300 | Yes | No | No |
| | 4500 | Yes | No | No |
| | 6064 | Yes | No | No |
| | 6140 | Yes | No | No |
| | 4400 | Yes | No | No |
| | 4700 | Yes | No | No |
| QLogic | 6140 | No | Yes | No |
| | 6142 | No | Yes | No |
| | SANbox2-8 | Yes | No | No |

| Vendor | Model | Fibre Channel | iSCSI | SAS |
|--------------|------------|---------------|-------|-----|
| | SANbox2-16 | Yes | No | No |
| | SANbox5200 | Yes | No | No |
| | SANbox3600 | Yes | No | No |
| | SANbox3800 | Yes | No | No |
| | SANbox5208 | Yes | No | No |
| | SANbox5600 | Yes | No | No |
| | SANbox5800 | Yes | No | No |
| | SANbox9000 | Yes | No | No |
| PowerConnect | 5324 | No | Yes | No |
| | 6024 | No | Yes | No |

If required, make the appropriate configuration changes for *each* switch that is connected to the storage array.

Refer to the switch's documentation for information about how to install the switch and how to use the configuration utilities that are supplied with the switch.

 **NOTE** Refer to the Compatibility Matrix (<http://www.lsi.com/CompatibilityMatrix/>) for the latest information. As new switches are tested and certified to work with various hardware and software combinations, they are added to the Compatibility Matrix.

Procedure – Installing and Configuring Switches

1. Install your switch according to the vendor's documentation.
2. Use the Compatibility Matrix at the website <http://www.lsi.com/compatibilitymatrix/> to obtain this information:
 - The latest hardware compatibility information
 - The models of the switches that are supported
 - The firmware requirements and the software requirements for the switches
3. Update the switch's firmware by accessing it from the applicable switch vendor's website.

This update might require that you cycle power to the switch.
4. Find your switch in the following table to see whether you need to make further configuration changes. Use your switch's configuration utility to make the changes.

Supported Switch Vendors and Required Configuration Changes

| Switch Vendor | Configuration Changes Required? | Next Step |
|---------------|---|---|
| Brocade | Yes Change the In-Order Delivery (IOD) option to ON. | Make the change, and go to “Step 3 – Installing the Host Bus Adapters for the CDE4900 Controller-Drive Tray Configuration.” |
| Cisco | Yes Change the In-Order Delivery (IOD) option to ON. | Make the change, and go to “Step 3 – Installing the Host Bus Adapters for the CDE4900 Controller-Drive Tray Configuration.” |
| McData | No | “Step 3 – Installing the Host Bus Adapters for the CDE4900 Controller-Drive Tray Configuration.” |
| QLogic | No | “Step 3 – Installing the Host Bus Adapters for the CDE4900 Controller-Drive Tray Configuration.” |
| PowerConnect | No | “Step 3 – Installing the Host Bus Adapters for the CDE4900 Controller-Drive Tray Configuration.” |

Step 3 – Installing the Host Bus Adapters for the CDE4900 Controller-Drive Tray Configuration

Key Terms

HBA host port

The physical and electrical interface on the host bus adapter (HBA) that provides for the connection between the host and the controller. Most HBAs will have either one or two host ports. The HBA has a unique World Wide Identifier (WWID) and each HBA host port has a unique WWID.

HBA host port world wide name

A 16-character unique name that is provided for each port on the host bus adapter (HBA).

host bus adapter (HBA)

A physical board that resides in the host. The HBA provides for data transfer between the host and the controllers in the storage array over the I/O host interface. Each HBA contains one or more physical ports.

Things to Know – Host Bus Adapters and Ethernet Network Interface Cards

- The CDE2600 controller-drive tray supports dual 6-Gb/s SAS host connections and optional host interface cards (HICs) for dual 6-Gb/s SAS, four 1-Gb/s iSCSI, two 10-Gb iSCSI, and four 8-Gb/s FC connections. The connections on a host must match the type (SAS HBAs for SAS, FC HBAs for FC, or iSCSI HBAs or Ethernet network interface cards [NICs] for iSCSI) of the HICs to which you connect them. For the best performance, HBAs for SAS and FC connections should support the highest data rate supported by the HICs to which they connect.
- For maximum hardware redundancy, you must install a minimum of two HBAs (for either SAS or FC host connections) or two NICs or iSCSI HBAs (for iSCSI host connections) in each host. Using both ports of a dual-port HBA or a dual-port NIC provides two paths to the storage array but does not ensure redundancy if an HBA or a NIC fails.



NOTE You can use the Compatibility Matrix to obtain information about the supported models of the HBAs and their requirements. Go to <http://www.lsi.com/compatibilitymatrix/>, and select the desired Developer Partner Program link. Check its Compatibility Matrix to make sure you have an acceptable configuration.

- Most of the HBAs, as shipped from the vendor, require updated firmware and software drivers to work correctly with the storage array. For information about the updates, refer to the website of the HBA vendor.

Procedure – Installing Host Bus Adapters

1. Go to <http://www.lsi.com/compatibilitymatrix/>, and select the desired Developer Partner Program link. Check its Compatibility Matrix to make sure you have an acceptable configuration.

The Compatibility Matrix provides this information:

- The latest hardware compatibility information
- The models of the HBAs that are supported
- The firmware requirements and the software requirements for the HBAs

2. Install your HBA according to the vendor documentation.



NOTE If your operating system is Windows Server 2008 Server Core, you might have additional installation requirements. Refer to the Microsoft Developers Network (MSDN) for more information about Windows Server 2008 Server Core. You can access these resources from www.microsoft.com.

3. Install the latest version of the firmware for the HBA. You can find the latest version of the firmware for the HBA at the HBA vendor website.



NOTE The remaining steps are general steps to obtain the HBA host port world wide name from the HBA BIOS utility. If you have installed the host context agent on all of your hosts, you do not need to perform these steps. If you are performing these steps, the actual prompts and screens vary depending on the vendor that provides the HBA. Also, some HBAs have software utilities that you can use to obtain the world wide name for the port instead of using the BIOS utility.

4. Reboot or start your host.
5. While your host is booting, look for the prompt to access the HBA BIOS utility.
6. Select each HBA to view its HBA host port world wide name.
7. Record the following information for each host and for each HBA connected to the storage array:
 - The name of each host
 - The HBAs in each host
 - The HBA host port world wide name of each port on the HBA

The following table shows examples of the host and HBA information that you must record.

Examples of HBA Host Port World Wide Names

| Host Name | Associated HBAs | HBA Host Port World Wide Name |
|----------------|---------------------------------|--|
| ICTENGINEERING | Vendor x, Model y (dual port) | 37:38:39:30:31:32:33:32 37:38:39:30:31:32:33:33 |
| | Vendor a, Model y (dual port) | 42:38:39:30:31:32:33:42 42:38:39:30:31:32:33:44 |
| ICTFINANCE | Vendor a, Model b (single port) | 57:38:39:30:31:32:33:52 |
| | Vendor x, Model b (single port) | 57:38:39:30:31:32:33:53 |

Step 4 – Installing the CDE4900 Controller-Drive Tray

Things to Know – General Installation

The power supplies meet standard voltage requirements for both domestic and worldwide operation.

 **NOTE** Make sure that the combined power requirements of your trays do not exceed the power capacity of your cabinet.

Procedure – Installing the CDE4900 Controller-Drive Tray

Airflow Direction Through and Clearance Requirements for the Controller-Drive Tray

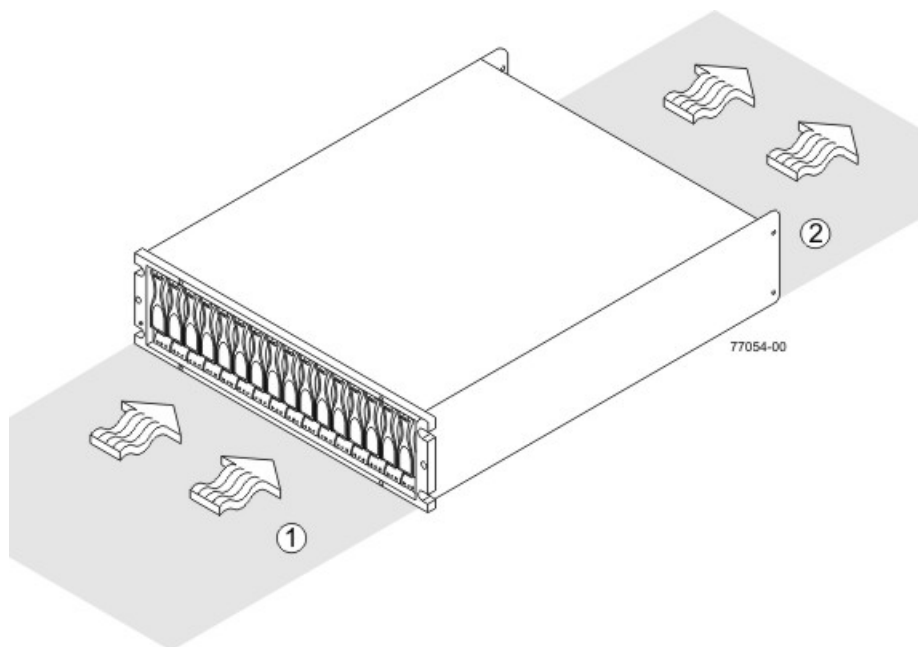

1. 76-cm (30-in.) clearance in front of the cabinet
2. 61-cm (24-in.) clearance behind the cabinet

 **WARNING (W09) Risk of bodily injury –**



>35 kg (70.5 lbs)

Three persons are required to safely lift the component.

1. Make sure that the cabinet is in the final location. Make sure that the cabinet installation site meets the clearance requirements.
2. Lower the feet on the cabinet, if required, to keep it from moving.
3. Install the mounting rails in the cabinet. For more information, refer to the installation instructions that are included with your mounting rails.

- If you are installing the mounting rails above an existing tray, position the mounting rails directly above the tray.
- If you are installing the mounting rails below an existing tray, allow 17.8-cm (7.00-in.) clearance below the existing tray.

⚠ ATTENTION Risk of equipment malfunction – To avoid exceeding the functional and environmental limits, install only drives that have been provided or approved by the original manufacturer. Not all controller-drive trays are shipped with pre-populated drives. System integrators, resellers, system administrators, or users of the controller-drive tray can install the drives.

📌 NOTE Make sure that you place the controller-drive tray in the middle portion of the cabinet while allowing room for drive trays to be placed above and below the controller-drive tray. As you add drive trays, position them below and above the controller-drive tray, alternating so that the cabinet does not become top heavy.

4. With the help of two other persons, slide the rear of the controller-drive tray onto the mounting rails. Make sure that the top mounting holes on the controller-drive tray align with the mounting rail holes of the cabinet.

The rear of the controller-drive tray slides into the slots on the mounting rails.

Securing the Controller-Drive Tray to the Cabinet

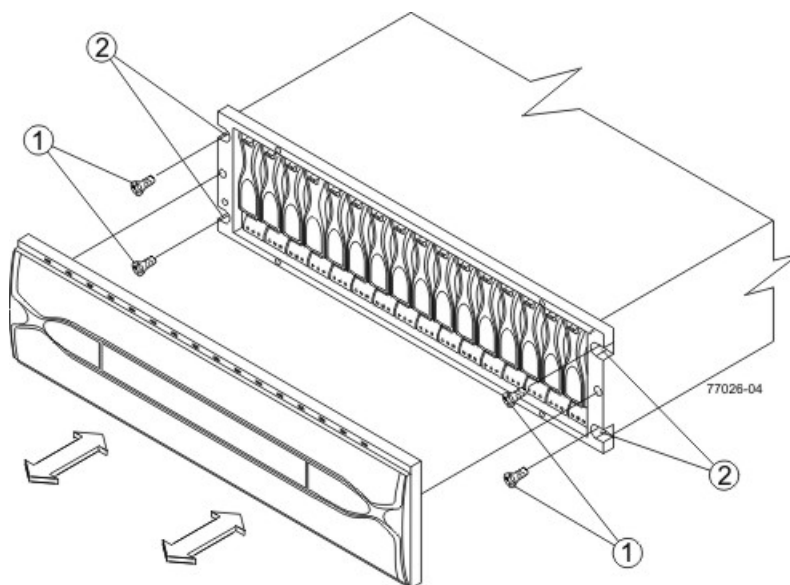

1. Screws
2. Mounting Holes

📌 NOTE The rear of the controller-drive tray contains two controllers. The top of the controller-drive tray is the side with the labels.

5. Secure screws in the top mounting holes and the bottom mounting holes on each side of the controller-drive tray.
6. Secure the back of the controller-drive tray to the cabinet by using two screws to attach the flanges on each side at the back of the controller-drive tray to the support rails.
7. Install the bezel on the front of the controller-drive tray.

8. Install the drive trays. Refer to "[Step 6 – Installing the Drive Trays for the CDE4900 Controller-Drive Tray Configurations](#)".

Step 5 – Connecting the CDE4900 Controller-Drive Tray to the Hosts

Key Terms

direct topology

A topology that does not use a switch.

See also switch topology.

switch topology

A topology that uses a switch.

See also direct topology.

topology

The logical layout of the components of a computer system or network and their interconnections. Topology deals with questions of what components are directly connected to other components from the standpoint of being able to communicate. It does not deal with questions of physical location of components or interconnecting cables. (The Dictionary of Storage Networking Terminology)

Things to Know – Host Channels



ATTENTION Possible hardware damage – To prevent electrostatic discharge damage to the tray, use proper antistatic protection when you handle tray components.

- Each controller has two or four host ports.
- Two of the host ports are standard and support 8-Gb/s, 4-Gb/s or 2 Gb/s Fibre Channel (FC) data rates. The data rate will auto-negotiate to the highest value supported by the host.
- Two of the host ports are optional, and, if present, are located on a replaceable host interface card (HIC). Two different types of HICs are supported. One option has two FC host ports with the same specifications as the standard host ports. The second option has two iSCSI host ports. The iSCSI host ports can be used for 10-Gb/s connections or 1-Gb/s connections. The data rate for the iSCSI ports must be set manually, and each data rate requires a different type of SFP transceiver.
- Labeling on the face plate of the HIC identifies the type of connection: FC or iSCSI. If no HIC is installed, a blank face plate covers the location for the HIC.
- Controller A is inverted from controller B, which means that its host channels are upside-down.

Host Channels on the Controllers – Rear View

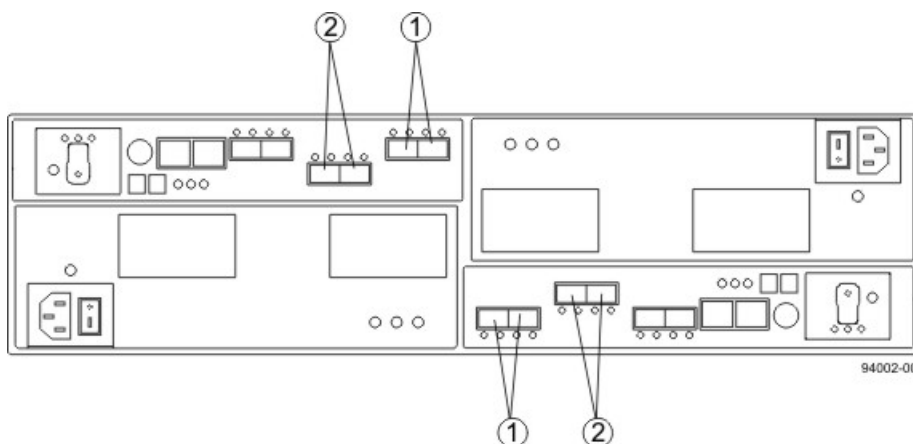

1. Standard Host Channels
2. Optional Host Channels



WARNING (W03) Risk of exposure to laser radiation – Do not disassemble or remove any part of a Small Form-factor Pluggable (SFP) transceiver because you might be exposed to laser radiation.

Procedure – Connecting Host Cables



IMPORTANT Make sure that you have installed your HBAs. Refer to the documentation for your HBAs for information about how to install the HBA and how to use the supplied configuration utilities.

The type of HICs, Fibre Channel (FC) or iSCSI, must match the type of the host bus adapters (HBAs) to which you connect them. If you are mixing FC host connections and iSCSI host connections, each host connection of a redundant pair must connect to the same type of host port, one on controller A and one on controller B.

Fiber-optic connections for 8-Gb/s FC require special SFP transceivers that support the higher data rate. Similarly, 10-Gb/s fiber-optic iSCSI connections require special SFP transceivers. 10-Gb/s iSCSI connections require both special SFP transceivers and Ethernet cables. SFP transceivers installed in the controller, the host, and, optionally, the switch must all support the same data rate to achieve the best performance.

If you are using iSCSI with a fabric topology, the iSCSI connections might require a different type of switch from the FC connections.

Refer to the figures just below for example cabling patterns.

1. Make sure that the appropriate type of SFP transceiver is inserted into the host channel.
2. If a black, plastic plug is in the SFP transceiver, remove it.

3. Starting with the first host channel of each controller, plug one end of the cable into the SFP transceiver in the host channel.

The cable is an Ethernet cable with RJ-45 connectors for 1-Gb/s iSCSI connections, or a fiber-optic cable for all other types of connections.

4. Plug the other end of the cable into an HBA in the host (direct topology) or into a switch (fabric topology).
5. Affix a label to each end of the cable with this information. A label is very important if you need to disconnect cables to service a controller. Include this information on the labels:
 - The host name and the HBA port (for direct topology)
 - The switch name and the port (for fabric topology)
 - The controller ID (for example, controller A)
 - The host channel ID (for example, host channel 1)

Example label abbreviation – Assume that a cable is connected between port 1 in HBA 1 of a host named Engineering and host channel 1 of controller A. A label abbreviation could be as follows.

Heng-HBA1/P1, CtA-Hch1

6. Repeat step 1 through step 5 for each controller and host channel that you intend to use.



NOTE If you do not use a Fibre Channel host port, remove the SFP transceiver. You might be able to use this SFP transceiver in a drive channel port or in an ESM on a drive tray.

Direct Topology – One Host and a Dual-Controller Controller-Drive Tray

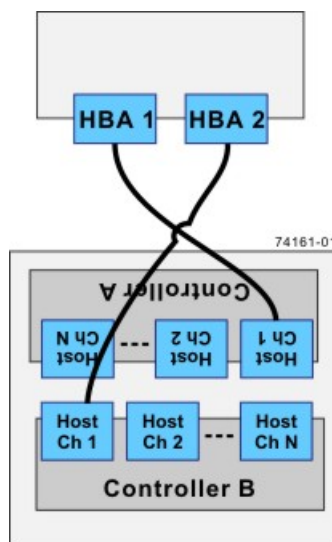

The box on the top in is the host, and the box on the bottom is the controller-drive tray.

Fabric Topology – One Host and a Dual-Controller Controller-Drive Tray with a Switch

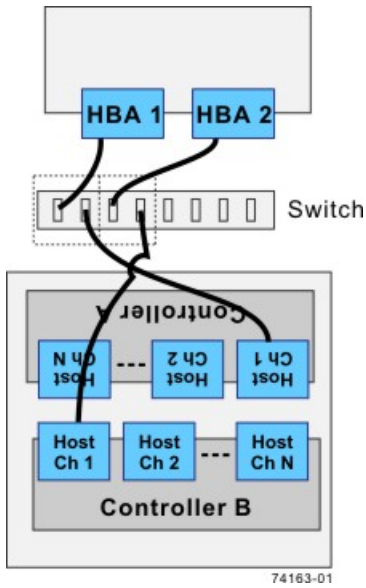

The box on the top of the switch is the host, and the box on the bottom is the controller-drive tray.

Mixed Topology – Three Hosts and a Dual-Controller Controller-Drive Tray

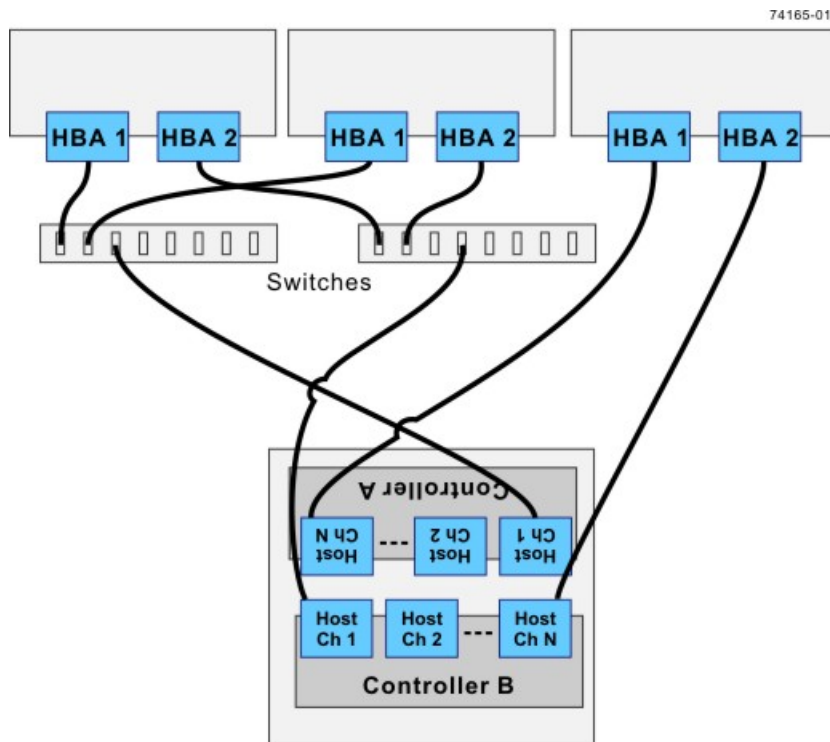

The boxes on the top of the switch are the hosts, and the box on the bottom is the controller-drive tray.



IMPORTANT The highest numbered host channel is generally used for Remote Volume Mirroring connections. If Remote Volume Mirroring connections are required, do not connect a host to the highest numbered host channel.

Step 6 – Installing the Drive Trays for the CDE4900 Controller-Drive Tray Configurations

Things to Know – General Installation

 **IMPORTANT** If you are installing the drive tray in a cabinet with other trays, make sure that the combined power requirements of the drive tray and the other trays do not exceed the power capacity of your cabinet.

- Special site preparation is not required for this drive tray beyond what is normally found in a computer lab environment.
- The power supplies meet standard voltage requirements for both domestic and worldwide operation.
- If you are installing drive trays and the controller-drive tray at the same time, take these precautions:
 - Install the controller-drive tray in a location within the cabinet that lets you evenly distribute the drive trays around the controller-drive tray.
 - Keep as much weight as possible in the bottom half of the cabinet.

 **IMPORTANT** After you install the drive tray, you might replace drives or install additional drives. If you replace or add more than one drive without powering down the drive tray, install the drives one at a time. Wait 10 seconds after you insert each drive before inserting the next one.

For Additional Information on Drive Tray Installation

Refer to the *Storage System Site Preparation Guide* on the SANtricity ES Storage Manager Installation DVD for important considerations about cabinet installation.

Procedure – Installing the FC4600 Drive Tray

 **WARNING (W09) Risk of bodily injury –**



>35 kg (70.5 lbs)

Three persons are required to safely lift the component.

 **WARNING (W05) Risk of bodily injury –** If the bottom half of the cabinet is empty, do not install components in the top half of the cabinet. If the top half of the cabinet is too heavy for the bottom half, the cabinet might fall and cause bodily injury. Always install a component in the lowest available position in the cabinet.

Install the FC4600 drive tray into an industry standard cabinet.

This procedure describes how to install the mounting rails into an industry standard cabinet.

⚠ ATTENTION Possible hardware damage – To prevent electrostatic discharge damage to the tray, use proper antistatic protection when handling tray components.

1. Make sure that the cabinet is in the final location. Make sure that you meet the clearance requirements shown below.

Drive Tray Airflow and Clearance Requirements

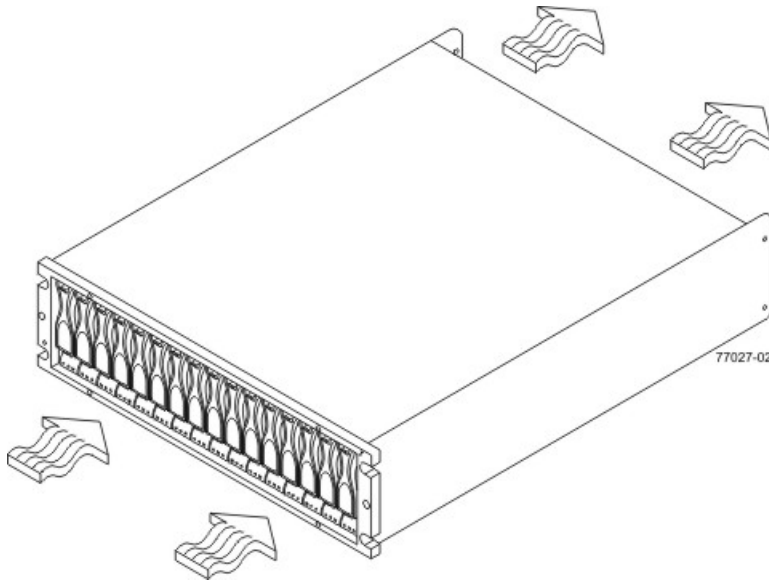

1. 76 cm (30 in.) clearance in front of the cabinet
2. 61 cm (24 in.) clearance behind the cabinet

📌 NOTE Fans pull air through the tray from front to rear across the drives.

2. Lower the feet on the cabinet to keep the cabinet from moving.
3. Remove the drive tray and all contents from the shipping carton.
4. Position the mounting rails in the cabinet.

Positioning the Mounting Rails in the Cabinet

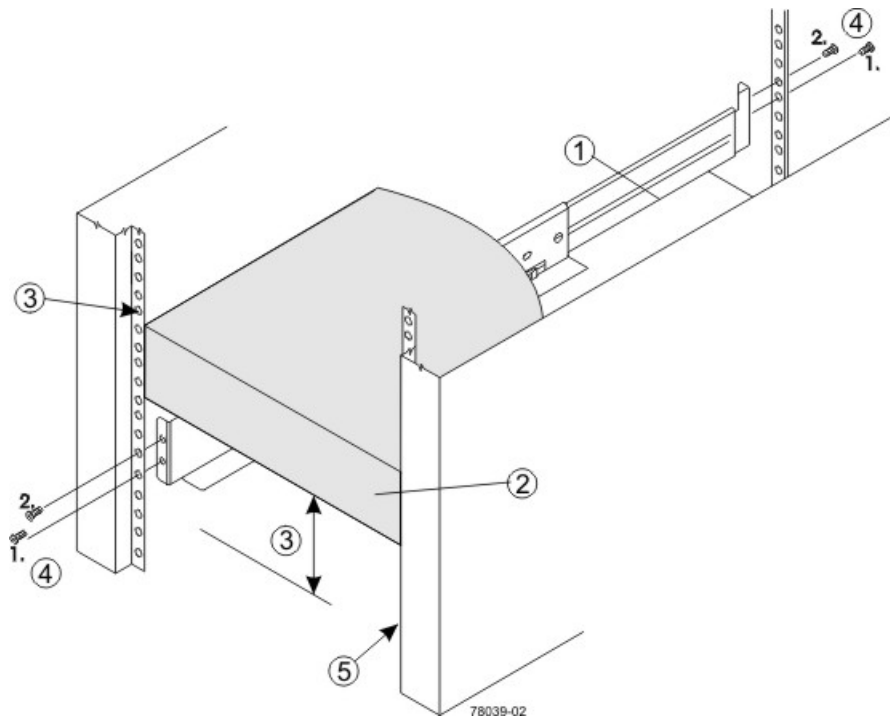

1. Mounting Rail
2. Existing Tray
3. Clearance Above and Below the Existing Tray
4. Screws for Securing the Mounting Rail to the Cabinet (Front and Rear)
5. Industry Standard Cabinet

- If you are installing the mounting rails above an existing tray, position the mounting rails directly above the tray.
 - If you are installing the mounting rails below an existing tray, allow 8.8-cm (3.5-in.) vertical clearance for the drive tray.
5. Attach the mounting rails to the cabinet by performing these substeps:
 - a. Make sure that the adjustment screws on the mounting rail are loose so that the mounting rail can extend or contract as needed.

Attaching the Mounting Rails to the Cabinet

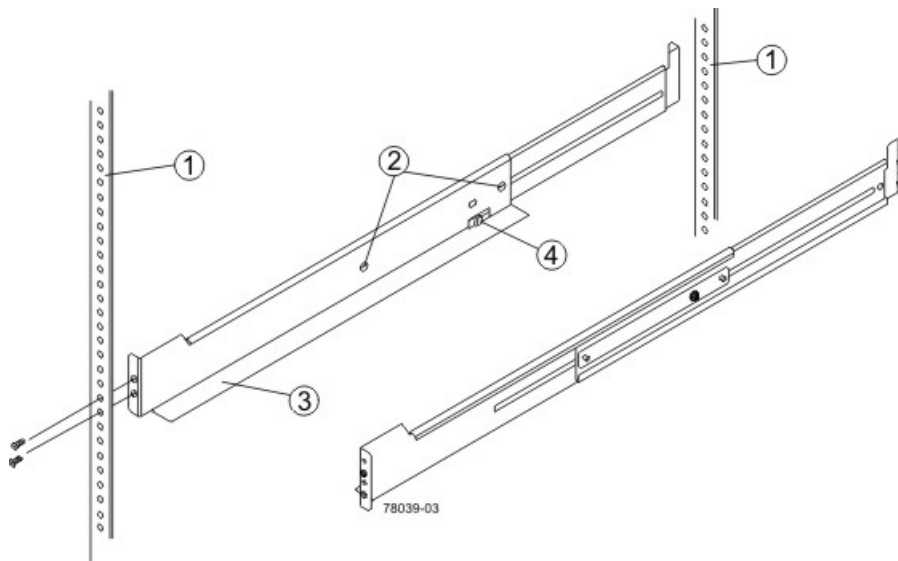

1. Cabinet Mounting Holes
 2. Adjustment Screws for Locking the Mounting Rail Length
 3. Mounting Rails
 4. Clip for Securing the Rear of the Drive Tray
- b. Place the mounting rail inside the cabinet, and extend the mounting rail until the flanges on the mounting rail touch the inside of the cabinet.
- c. Make sure that the alignment spacers on the front flange of the mounting rail fit into the mounting holes in the cabinet.

The front flange of each mounting rail has two alignment spacers. The alignment spacers are designed to fit into the mounting holes in the cabinet. The alignment spacers help position and hold the mounting rail.

Alignment Spacers on the Mounting Rail

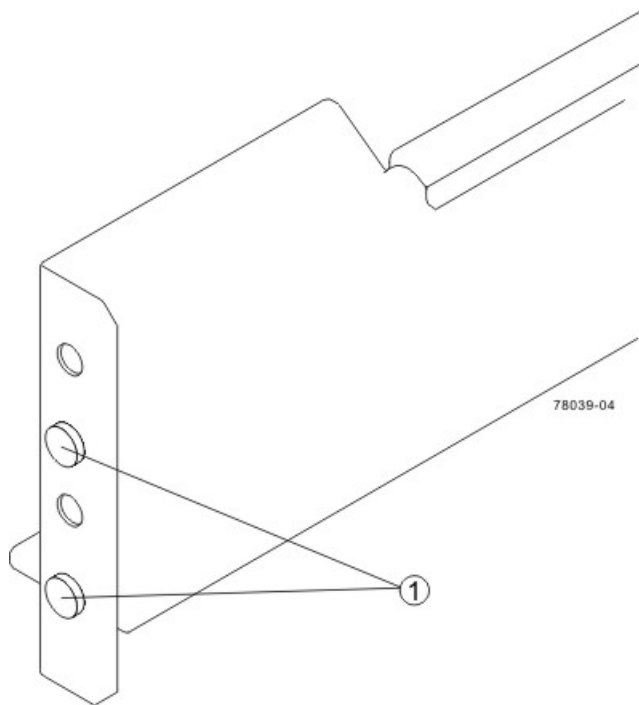

1. Alignment Spacers
 - d. Insert one M5 screw through the front of the cabinet and into the top captured nut in the mounting rail. Tighten the screw.
 - e. Insert two M5 screws through the rear of the cabinet and into the captured nuts in the rear flange in the mounting rail. Tighten the screws.
 - f. Tighten the adjustment screws on the mounting rail.
 - g. Repeat substep a through substep f to install the second mounting rail.
6. With the help of two other persons, slide the rear of the drive tray onto the mounting rails.

The mounting holes on the front flanges of the drive tray align with the mounting holes on the front of the mounting rails.
7. Secure the front of the drive tray to the cabinet by using four screws.

Attaching the Front of the Drive Tray

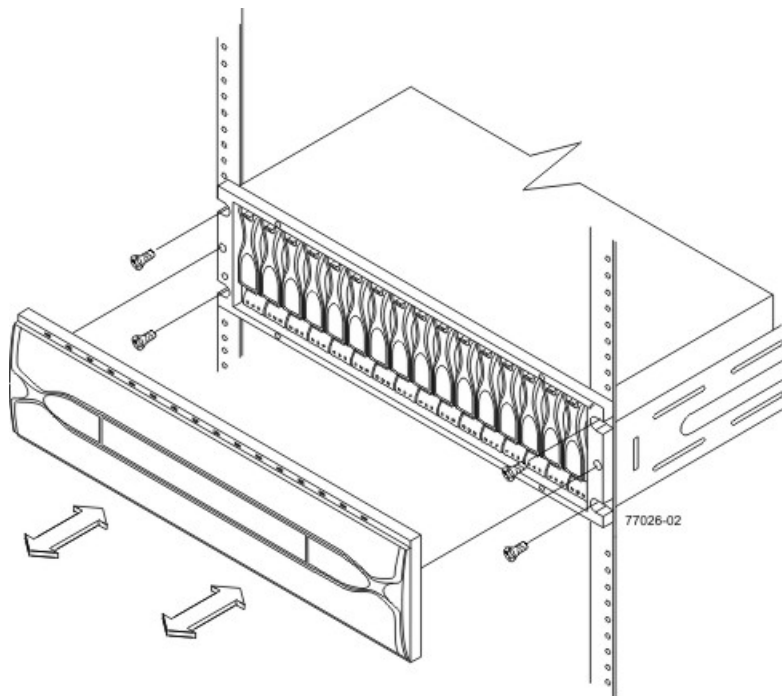

1. Screws for Securing the Front of the Drive Tray
8. Using two screws, attach the flange on each side of the rear of the drive tray to the mounting rails.

Things to Know – Adding Drive Trays to an Existing Storage Array

If you plan to add a new drive tray to an existing storage array, select one of the following procedures.

⚠ ATTENTION Potential loss of data access – If you plan to add a drive tray to an existing storage array while the storage array is powered on and receiving data I/O (method 3 below), you must contact a Customer and Technical Support representative to assist you in adding the drive tray.

🔥 IMPORTANT Drive trays can be powered by either the standard AC power supply or the optional DC power supply (–48 VDC). Before turning off any power switches on a DC-powered drive tray, you must disconnect the two-pole 20-amp circuit breaker.

Procedures for Adding a Drive Tray to an Existing Storage Array

| Addition Methods | Storage Array Receiving Power? | Storage Array Receiving Data? | Procedure |
|----------------------------------|--------------------------------|-------------------------------|--|
| 1 – Power but no I/O activity | Yes | No | |
| 2 – No power and no I/O activity | No | No | |
| 3 – Power and I/O activity | Yes | Yes | Contact a Customer and Technical Support representative before beginning this procedure. |

Things to Know – Link Rate Switch on the FC4600 Drive Tray



IMPORTANT Change the **Link Rate** switch only when the power is not turned on to the drive tray.

- Use the **Link Rate** switch to select the data transfer rate between the ESMs, the drives, and the controllers. The **Link Rate** switch is located on the rear of the drive tray on the ESMs.
- All drive trays that are connected to the same drive channel must be set to operate at the same data transfer rate (speed).
- The drives in the drive tray must support the selected link rate speed.
- The setting of the **Link Rate** switch determines the speed of the drives.
- If a drive in the drive tray does not support the link rate speed, the drive will show up as a bypassed drive in the storage management software.



IMPORTANT Change the **Link Rate** switch only when no power is applied to the drive tray.

Setting the Link Rate Switch on the FC4600 Drive Tray – Front View

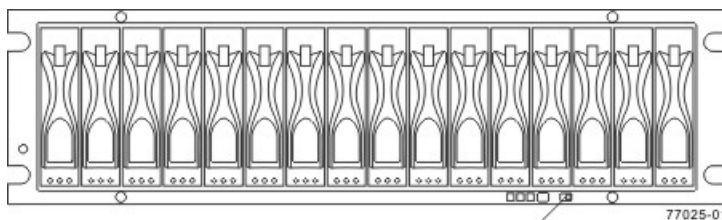

- Link Rate Switch (4 Gb/s or 2 Gb/s)

Link Rate LEDs on the FC4600 Drive Tray – Rear View

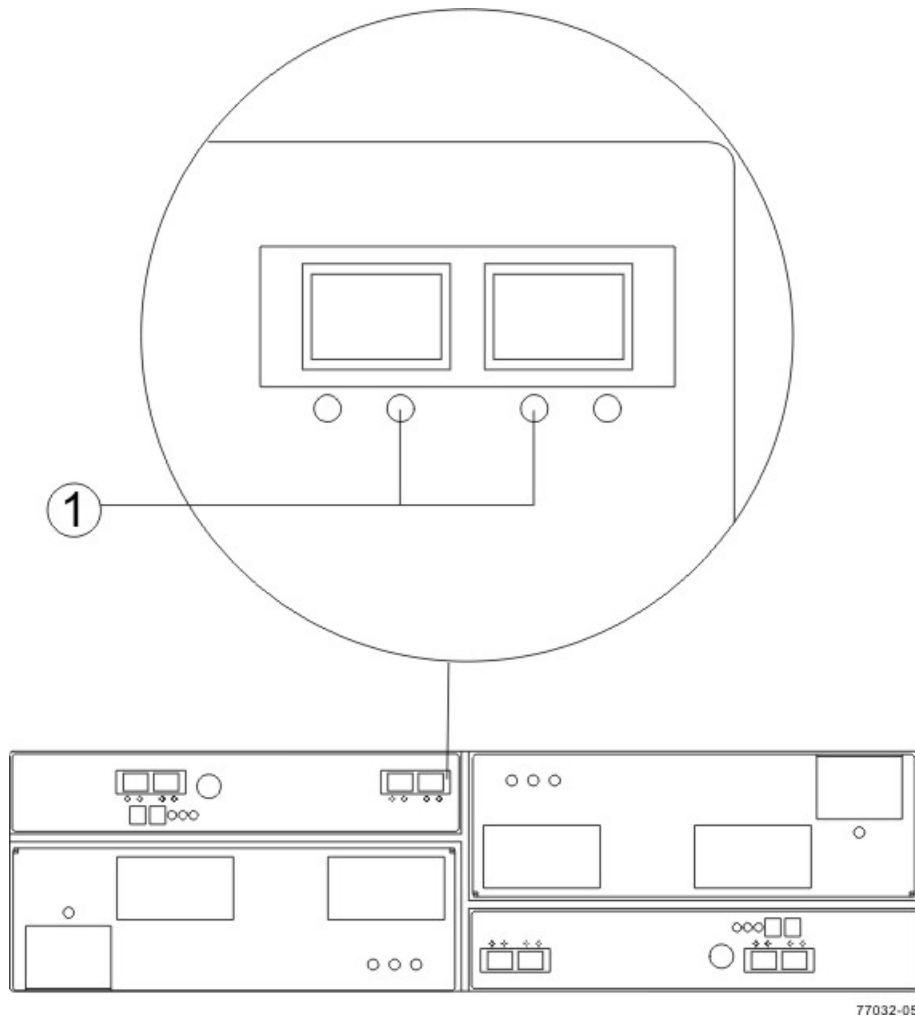

1. Link Rate LEDs Right On = 2 Gb/s Left and Right On = 4 Gb/s

Procedure – Setting the Link Rate Switch on the FC4600 Drive Tray

1. Check to see if the **Link Rate** switch is set to the 4-Gb/s data transfer rate.
 - If the link rate is set to 4-Gb/s, you do not need to change the setting.
 - If the link rate is set to 2-Gb/s, go to step 2.
2. Make sure that no power is applied to the drive tray.
3. Move the switch to the 4-Gb/s (left) position.

Step 7 – Connecting the CDE4900 Controller-Drive Tray to the Drive Trays

NOTE The maximum number of drives in a configuration is 112. These numbers include drives in the controller-drive tray and drives in the drive trays that are attached to the controller-drive tray.

Key Terms

drive channel

The path for the transfer of data between the controllers and the drives in the storage array.

environmental services monitor (ESM)

A canister in the drive tray that monitors the status of the components. An ESM also serves as the connection point to transfer data between the drive tray and the controller.

Things to Know – CDE4900 Controller-Drive Tray

ATTENTION Possible hardware damage – To prevent electrostatic discharge damage to the tray, use proper antistatic protection when you handle tray components.

- The CDE4900 controller-drive tray supports FC4600 drive trays for expansion. You cannot connect any other type of drive tray to the controller-drive tray.
- The maximum number of drives in the storage array is 112, including those in the CDE4900 controller-drive tray. Some CDE4900 controller-drive tray models have a lower limit for the number of drives. You must not exceed the limit for your model. Adding more drive trays makes the storage array invalid. The controllers cannot perform operations that modify the configuration, such as creating new volumes.
- Each controller has one dual-ported drive channel.
- Controller A is inverted from controller B, which means that its drive channels are upside-down.

Drive Channel Ports on the Controller-Drive Tray – Rear View

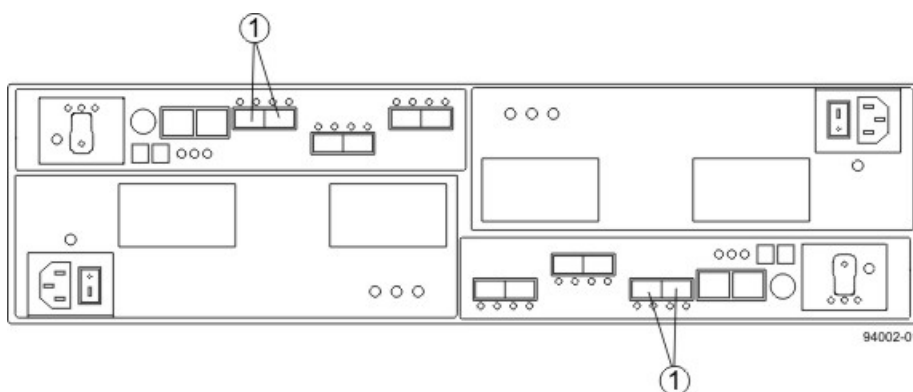

1. Drive Channel Ports

- A controller-drive tray has two redundant path pairs that are formed using one drive channel of controller A and one drive channel of controller B. See the following table for a list of the numbers of the redundant path pairs and the drive ports of the drive channels from which the redundant path pairs are formed.



IMPORTANT To maintain data access in the event of the failure of a controller, an ESM, or a drive channel, you must connect a drive tray or a string of drive trays to both drive channels on a redundant path pair.

Redundant Path Pairs on a Controller-Drive Tray

| Drive Ports on Controller A | Drive Channels on Controller A | Drive Ports on Controller B | Drive Channels on Controller B |
|-----------------------------|--------------------------------|-----------------------------|--------------------------------|
| Port 1 | Channel 1 | Port 1 | Channel 2 |
| Port 2 | Channel 1 | Port 2 | Channel 2 |

Procedure – Cabling a Drive Tray to a Storage Array with Power but No I/O Activity

The drive tray can have either standard power connections to an AC power source or the optional connections to a DC power source (–48 VDC).

1. Make sure that there is no I/O activity to the storage array.
2. Choose one of the following actions based on whether you will connect the drive tray with the standard power connections to an AC power source to the optional connections to a DC power source.
 - **Connect to a DC power source** – Perform [step 3](#) through [step 6](#).
 - **Connect to an AC power source** – Perform [step 7](#) through [step 11](#).
3. Disconnect the two-pole 20-amp circuit breaker for the storage array.
4. Make sure that all of the DC power switches on the DC-powered drive tray are turned off.
5. Connect the DC power connector cables to the DC power connectors on the rear of the drive tray.



NOTE The three source wires on the DC power connector cable (–48 VDC) connect the drive tray to centralized DC power plant equipment, typically through a bus bar located above the cabinet.



NOTE You do not need to connect the second DC power connection on each of the drive tray's DC power-fan canisters. The second DC power connection is for additional redundancy only and may be connected to a second DC power bus.

6. Have a qualified service person connect the other end of the DC power connector cables to the DC power plant equipment as follows:
 - a. Connect the brown –48 VDC supply wire to the negative terminal.
 - b. Connect the blue return wire to the positive terminal.
 - c. Connect the green/yellow ground wire to the ground terminal. You are finished with this procedure.
7. Add the AC-powered drive tray to the end of the series of existing drive trays (for cabling details, refer to the *Hardware Cabling Guide* and the related topics online or that document on the SANtricity ES Storage Manager Installation DVD).
8. Make sure that both of the Power switches on the drive tray are turned off.

9. Connect the primary AC power cords from the cabinets to the external power source.
10. Connect a cabinet power ladder (or power cords specific to your particular cabinet) to the AC power connector on each power-fan canister in the drive tray.
11. If you are installing other drive trays in the cabinet, connect a power cord to each power-fan canister in the drive trays.

Procedure – Cabling a Drive Tray to a Storage Array with No Power and No I/O Activity

The drive tray can have either standard power connections to an AC power source or the optional connections to a DC power source (–48 VDC).

 **IMPORTANT** Make sure that you do not turn on power to the drive tray until this document instructs you to do so. For the proper procedure for turning on the power, see “[Step 10 – Turning on the Power and Checking for Problems in a CDE4900 Controller-Drive Tray Configuration](#)”.

1. Add the drive tray to the end of the series of existing drive trays (for cabling details, refer to either the *Hardware Cabling* electronic document topics or the PDF on the SANtricity ES Storage Manager Installation DVD.
 2. Choose one of the following actions based on whether you will connect the drive tray with the standard power connections to an AC power source to the optional connections to a DC power source.
 - **Connect to a DC power source** – Perform [step 3](#) through [step 6](#).
 - **Connect to an AC power source** – Perform [step 7](#) through [step 9](#).
-

 **IMPORTANT** Before turning off any power switches on a DC-powered drive tray, you must disconnect the two-pole 20-amp circuit breaker.

3. Disconnect the two-pole 20-amp circuit breaker for the storage array.
 4. Make sure that all of the DC power switches on the DC-powered drive tray are turned off.
 5. Connect the DC power connector cables to the DC power connectors on the rear of the drive tray.
-

 **NOTE** The three source wires on the DC power connector cable (–48 VDC) connect the drive tray to centralized DC power plant equipment, typically through a bus bar located above the cabinet.

 **NOTE** You do not need to connect the second DC power connection on each of the drive tray’s DC power-fan canisters. The second DC power connection is for additional redundancy only and may be connected to a second DC power bus.

6. Have a qualified service person connect the other end of the DC power connector cables to the DC power plant equipment as follows:
 - a. Connect the brown –48 VDC supply wire to the negative terminal.
 - b. Connect the blue return wire to the positive terminal.
 - c. Connect the green/yellow ground wire to the ground terminal.
7. Make sure that both of the Power switches on the drive tray are turned off.
8. Connect the primary AC power cords from the cabinets to the external power source.
9. Connect a cabinet power ladder (or power cords specific to your particular cabinet) to the AC power connector on each power-fan canister in the drive tray.

10. If you are installing other drive trays in the cabinet, connect a power cord to each power-fan canister in the drive trays.

Step 8 – Connecting the Ethernet Cables

Key Terms

in-band management

A method to manage a storage array in which a storage management station sends commands to the storage array through the host input/output (I/O) connection to the controller.

See also out-of-band management.

out-of-band management

A method to manage a storage array in which a storage management station sends commands to the storage array through the Ethernet connections on the controller.

See also in-band management.

Things to Know – Connecting Ethernet Cables



ATTENTION Risk of security breach – Connect the Ethernet ports on the controller tray to a private network segment behind a firewall. If the Ethernet connection is not protected by a firewall, your storage array might be at risk of being accessed from outside of your network.

- These Ethernet connections are intended for out-of-band management and have nothing to do with the iSCSI host interface cards (HICs), whether 1Gb/s or 10Gb/s.
- Ethernet port 2 on each controller is reserved for access by your Customer and Technical Support representative.
- In limited situations in which the storage management station is connected directly to the controller tray, you must use an Ethernet crossover cable. An Ethernet crossover cable is a special cable that reverses the pin contacts between the two ends of the cable.

Procedure – Connecting Ethernet Cables

Perform these steps to connect Ethernet cables for out-of-band management. If you use only in-band management, skip these steps.

1. Connect one end of an Ethernet cable into the Ethernet port 1 on controller A.
2. Connect the other end to the applicable network connection.
3. Repeat step 1 through step 2 for controller B.

Step 9 – Connecting the Power Cords in a CDE4900 Controller-Drive Tray Configuration

The CDE4900 controller-drive tray and the FC4600 drive tray can have either standard power connections to an AC power source or the optional connections to a DC power source (–48 VDC).

IMPORTANT Make sure that you do not turn on the power to the controller-drive tray or the connected drive trays until this documentation instructs you to do so. For the correct procedure for turning on the power, see [“Procedure – Turning On the Power to the Storage Array and Checking for Problems in a CDE4900 Controller-Drive Tray Configuration.”](#)

Things to Know – AC Power Cords

- For each AC power connector on the drive tray, make sure that you use a separate power source in the cabinet. Connecting to independent power sources maintains power redundancy.
- To ensure proper cooling and assure availability, the drive trays always use two power supplies.
- You can use the power cords shipped with the controller-drive tray with typical outlets used in the destination country, such as a wall receptacle or an uninterruptible power supply (UPS). These power cords, however, are not intended for use in most EIA-compliant cabinets.

Things to Know – DC Power Cords

If your controller-drive trays have the DC power option installed, review the following information.

DC Power Cable

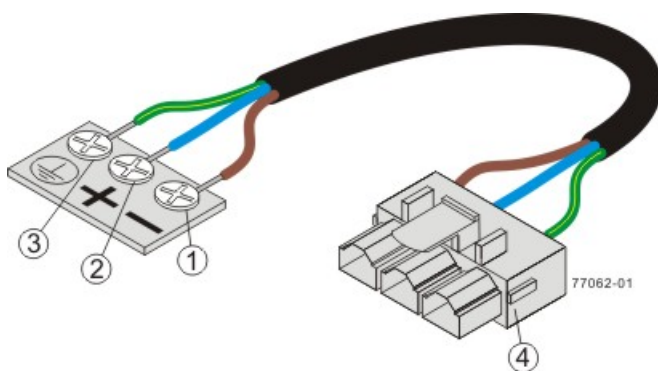

- Supply (negative), brown wire, –48 VDC
- Return (positive), blue wire
- Ground, green/yellow wire
- DC power connector

- Each power-fan canister has two DC power connectors. Be sure to use a separate power source for each power-fan canister in the drive tray to maintain power redundancy. You may, optionally, connect each DC power connector on the same power-fan canister to a different source for additional redundancy.
- A two-pole 30-amp circuit breaker is required between the DC power source and the drive tray for over-current and short-circuit protection.

WARNING (W14) Risk of bodily injury – A qualified service person is required to make the DC power connection according to NEC and CEC guidelines.

Procedure – Connecting AC Power Cords

1. Make sure that the circuit breakers in the cabinet are turned off.
2. Make sure that both of the Power switches on the controller-drive tray are turned off.
3. Connect the primary power cords from the cabinet to the external power source.
4. Connect a cabinet interconnect power cord (or power cords specific to your particular cabinet) to the AC power connector on each power canister in the drive tray.
5. If you are installing other drive trays in the cabinet, connect a power cord to each power canister in the drive trays.

Procedure – Connecting DC Power Cords



WARNING (W14) Risk of bodily injury – A qualified service person is required to make the DC power connection according to NEC and CEC guidelines.



NOTE Make sure that you do not turn on power to the controller-drive tray until this guide instructs you to do so. For the proper procedure for turning on the power, see .



NOTE Before turning off any power switches on a DC-powered controller-drive tray, you must disconnect the two-pole 20-amp circuit breaker.

1. Disconnect the two-pole 20-amp circuit breaker for the storage array.
2. Make sure that all of the DC power switches on the DC-powered controller-drive tray are turned off.
3. Make sure that all of the DC power switches on the DC-powered drive trays are turned off.
4. Connect the DC power connector cables to the DC power connectors on the rear of the controller-drive tray and the drive trays.



NOTE The three source wires on the DC power connector cable (–48 VDC) connect the controller-drive tray to centralized DC power plant equipment, typically through a bus bar located above the cabinet.



NOTE It is not mandatory that the second DC power connection on each of the drive tray's DC power-fan canisters be connected. The second DC power connection is for additional redundancy only and may be connected to a second DC power bus.

5. Have a qualified service person connect the other end of the DC power connector cables to the DC power plant equipment as follows:
 - a. Connect the brown –48 VDC supply wire to the negative terminal.
 - b. Connect the blue return wire to the positive terminal.
 - c. Connect the green/yellow ground wire to the ground terminal.

Step 10 – Turning on the Power and Checking for Problems in a CDE4900 Controller-Drive Tray Configuration

Once you complete this task, you can begin to install the software and perform basic configuration tasks on your storage array. Continue with the *Initial Configuration and Software Installation* in these electronic document topics or through the PDF that is available on the SANtricity ES Storage Manager Installation DVD.

Procedure – Turning On the Power to the Storage Array and Checking for Problems in a CDE4900 Controller-Drive Tray Configuration

 **IMPORTANT** You must turn on the power to all of the connected drive trays before you turn on the power for the controller-drive tray. Performing this action makes sure that the controllers recognize each attached drive tray.

 **NOTE** While the power is being applied to the trays, the LEDs on the front and the rear of the trays come on and go off intermittently.

1. Turn on both Power switches on each drive tray that is attached to the controller-drive tray. Depending on your configuration, it can take several minutes for each drive tray to complete the power-on process.







 **IMPORTANT** Before you go to step 2, check the LEDs on the drive trays to verify that the power was successfully applied to all of the drive trays. Wait 30 seconds after turning on the power to the drive trays before turning on the power to the controller-drive tray.







2. Turn on both Power switches on the rear of the controller-drive tray. Depending on your configuration, it can take several minutes for the controller-drive tray to complete the power-on process.
3. Check the LEDs on the front and the rear of the controller-drive tray and the attached drive trays.
4. If you see any amber LEDs, make a note of their location.

Things to Know – LEDs on the Controller-Drive Tray

LEDs on the Controller-Drive Tray

| LED | Symbol | Location (Canisters) | Function |
|-------|---|--------------------------------|---|
| Power |  | Power-fan Interconnect-battery | <ul style="list-style-type: none"> ▪ On – The canister has power. ▪ Off – The canister does not have power. <p>NOTE – The controller canisters do not have a Power LED. They receive their power from the power supplies inside the power-fan canisters.</p> |

| LED | Symbol | Location (Canisters) | Function |
|---------------------------------|---|--|--|
| Battery Charging |  | Battery | <ul style="list-style-type: none"> On – The battery is charged and ready. Off – There is a battery fault or the battery has discharged. Blinking – The battery is charging. |
| Service Action Allowed |  | Drive (left light, no symbol) Power-fan Controller Battery | On – You can remove the canister safely. |
| Service Action Required (Fault) |  | Front frame Drive (middle light, no symbol) Power-fan Controller Battery | On – A problem exists with the canister. |
| Locate |  | Front frame | On – This LED assists in locating the tray. |
| Host Channel Speed |  | Controller | <p>The speed of the host channel is indicated:</p> <ul style="list-style-type: none"> Left LED on – 2 Gb/s Right LED on – 4 Gb/s Left LED and right LED on – 8 Gb/s |
| Host Channel Connection (iSCSI) |  | Controller | <p>The status of the host channel is indicated:</p> <ul style="list-style-type: none"> “L” LED on – A link is established. “A” LED on – Activity (data transfer) is present. |
| Drive Port Bypass |  | Controller | On – A bypassed port is indicated. |

| LED | Symbol | Location (Canisters) | Function |
|---|---|---|---|
| Drive Channel Speed |  | Controller | The speed of the drive channel is indicated: <ul style="list-style-type: none"> Right LED on – 2 Gb/s Left LED and right LED on – 4 Gb/s |
| Cache Active |  | Controller | The activity of the cache is indicated: <ul style="list-style-type: none"> Blinking – Data is in the cache. Off – No data is in the cache. |
| Seven Segment ID Numeric Display and Diagnostic Display |  | Controller | The tray ID or a diagnostic code is indicated. For more information, refer to the table below on Seven Segment Diagnostic Display codes. For example, if some of the cache memory dual in-line memory modules (DIMMs) are missing in a controller, error code L8 appears in the diagnostic display. |
| AC power |  | Power-fan NOTE – The LED is directly above or below the AC power switch and the AC power connector. | Indicates that the power supply is receiving AC power input. |
| DC power |  | Power-fan NOTE – The LED is directly above or below the DC power switch and the DC power connector. | Indicates that the power supply is receiving DC power input. |
| Direct Current Enabled |  | Power-fan | Indicates that the power supply is outputting DC power. |
| Ethernet Speed and Ethernet Activity |  | Controller | The speed of the Ethernet ports and whether a link has been established are indicated: |







| LED | Symbol | Location (Canisters) | Function |
|-----|--------|----------------------|---|
| | | | <ul style="list-style-type: none"> ▪ Left LED on – 1000BASE-T speed. ▪ Left LED off – 100BASE-T or 10BASE-T speed. ▪ Right LED on – A link is established. ▪ Right LED off – No link exists. ▪ Right LED blinking – Activity is occurring. |

Supported Diagnostic Codes

| Diagnostic Code | Description |
|-----------------|---|
| L0 | The controller types are mismatched. |
| L1 | The interconnect-battery canister is missing. |
| L2 | A persistent memory error has occurred. |
| L3 | A persistent hardware error has occurred. |
| L4 | A persistent data protection error has occurred. |
| L5 | The auto-code synchronization (ACS) has failed. |
| L6 | An unsupported host interface card is installed. |
| L7 | The sub-model identifier is not set or is mismatched. |
| L8 | A memory configuration error has occurred. |
| L9 | A link speed mismatch has occurred. |
| LA | Reserved |
| Lb | A host card configuration error has occurred. |
| LC | A persistent cache backup configuration error has occurred. |
| Ld | Mixed cache memory DIMMs are present. |
| LE | Uncertified cache memory DIMM sizes exist. |
| LF | Lockdown with limited SYMbol support exists. |
| LH | A controller firmware mismatch has occurred. |

General Behavior of the LEDs on the Drive Trays

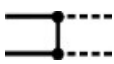
LED Symbols and General Behavior on the Drive Trays

| LED | Symbol | Location | General Behavior |
|---------------------------------|---|---|---|
| Power |  | Drive tray ESM canister Power-fan canister | On – Power is applied to the drive tray or the canister. Off – Power is not applied to the drive tray or the canister. |
| Service Action Allowed |  | ESM canister Power-fan canister Drive | On – It is safe to remove the ESM canister, the power-fan canister, or the drive. Off – Do not remove the ESM canister, the power-fan canister, or the drive. The drive has an LED but no symbol. |
| Service Action Required (Fault) |  | ESM canister Power-fan canister Drive | On – When the drive tray LED is on, a component within the drive tray needs attention. On – The ESM canister, the power-fan canister, or the drive needs attention. Off – The ESM canister, the power-fan canister, and the drive are operating normally. The drive has an LED but no symbol. |
| Locate |  | Front bezel on the drive tray | On or blinking – Indicates the drive tray that you are trying to find. |
| Over-Temperature |  | Front bezel on the DE6900 drive tray | On – The temperature of the drive tray has reached an unsafe condition. Off – The temperature of the drive tray is within operational range. |
| Drive Port Bypass |  | ESM canister | Indicates if a port has been bypassed. |
| Drive Channel Speed |  | ESM canister | Indicates the speed of the drive channel: If the right LED is On -- 2 Gb/s If both LED are Off -- 4 Gb/s |

| LED | Symbol | Location | General Behavior |
|------------------------|---------|--|--|
| AC Power | AC ~ | ESM canister Power-fan canister Note LED is directly above or below AC Power Switch and AC Power Connectors | On – AC power is present. Off – AC power is not present. |
| DC Power (optional) | DC — | Power-fan canister Note LED is directly above or below DC Power Switch and DC Power Connectors | On – Regulated DC power from the power canister and the fan canister is present. Off – Regulated DC power from the power-fan canister is not present. |
| DC Power | DC — | Power-fan canister | Indicates the power supply is outputting DC power |

LEDs on the FC4600 Drive Tray

LEDs on the FC4600 – Front View

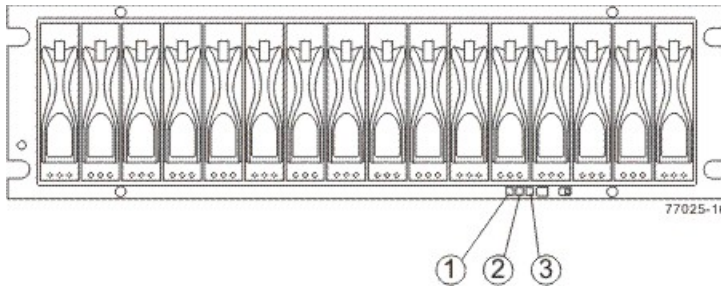

1. Drive Tray Locate LED
2. Drive Tray Service Action Required LED
3. Power LED

LEDs on the FC4600 Left End Cap

| Location | LED | Color | On | Off |
|----------|-------------------------|-------|--|----------------|
| 1 | Drive Tray Locate | White | Identifies a drive tray that you are trying to find. | Normal status. |
| 2 | Service Action Required | Amber | A component within the drive tray needs attention. | Normal status. |

| Location | LED | Color | On | Off |
|----------|-------|-------|-------------------|-----------------------|
| 3 | Power | Green | Power is present. | Power is not present. |

LEDs on the FC4600 ESM Canister

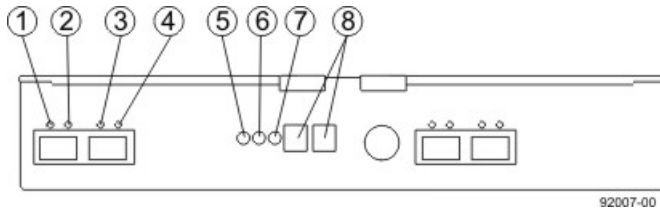

1. ESM Link Fault LED (Port 1A Bypass)
2. ESM Link LED (Port 1A Data Rate)
3. ESM Link LED (Port 1B Data Rate)
4. ESM Link Fault LED (Port 1B Bypass)
5. ESM Service Action Allowed LED
6. ESM Service Action Required LED
7. ESM Power LED
8. Seven-Segment Tray ID

LEDs on the FC4600 ESM Canister

| Location | LED | Color | On | Off |
|----------|---------------------------------|-------|--|---|
| 1 | ESM Link Fault (Port 1A Bypass) | Amber | A link error has occurred. | No link error has occurred. |
| 2 | ESM Link (Port 1A) | Green | The link is up. | A link error has occurred. |
| 3 | ESM Link (Port 1B Bypass) | Green | The link is up. | A link error has occurred. |
| 4 | ESM Link Fault (Port 1B) | Amber | A link error has occurred. | No link error has occurred. |
| 5 | ESM Service Action Allowed | Blue | The ESM can be removed safely from the drive tray. | The ESM cannot be removed safely from the drive tray. |
| 6 | ESM Service Action Required | Amber | A fault exists within the ESM. | Normal status. |
| 7 | ESM Power | Green | Power to the ESM is present. | Power is not present to the ESM. |

| Location | LED | Color | On | Off |
|----------|-----------------------|-------|--|-----------------|
| 8 | Seven-Segment Tray ID | Green | For more information, see “Supported Diagnostic Codes on the Seven-Segment Display”. | Not applicable. |

LEDs on the FC4600 Power Canister

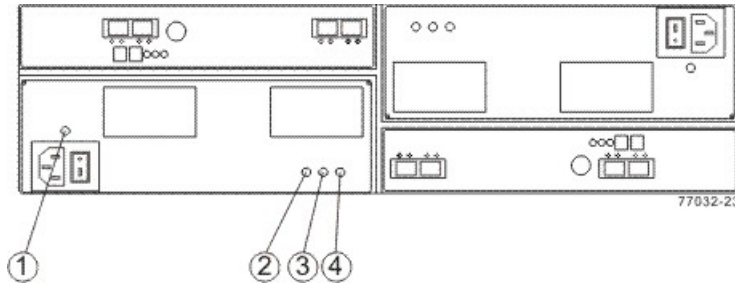

1. Power AC Power LED
2. Power Service Action Allowed LED
3. Power Service Action Required LED
4. Power DC Power LED

LEDs on the FC4600 Power Canister

| Location | LED | Color | On | Off |
|----------|-------------------------------|-------|---|--|
| 1 | Power AC Power | Green | AC power to the power canister is present. | AC power to the power canister is not present. |
| 2 | Power Service Action Allowed | Blue | The power canister can be removed safely from the drive tray. | The power canister cannot be removed safely from the drive tray. |
| 3 | Power Service Action Required | Amber | A fault exists within the power canister. | Normal status. |
| 4 | Power DC Power | Green | DC power from the power canister is available. | DC power from the power canister is not available. |

LEDs on the FC4600 Drives

LEDs on the FC4600 Drive

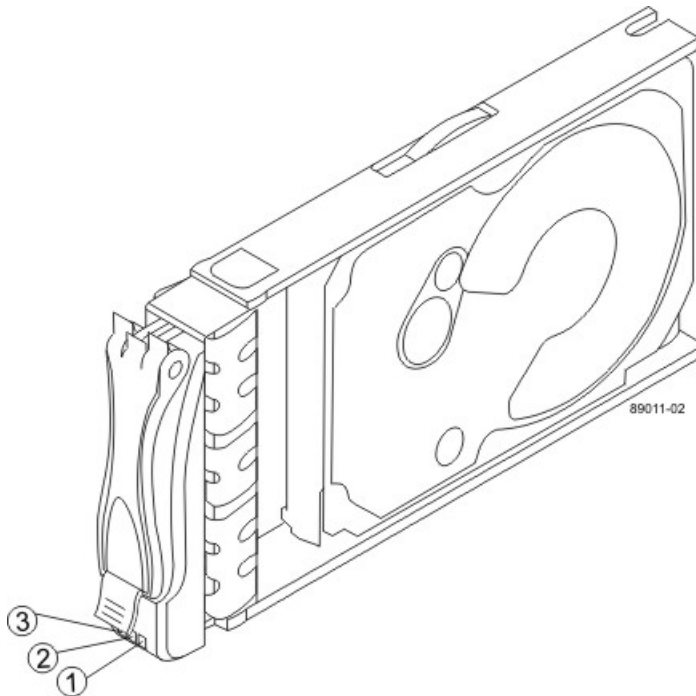

1. Drive Power LED
2. Drive Service Action Required LED
3. Drive Service Action Allowed LED

LEDs on the Drives

| Location | LED | Color | On | Blinking | Off |
|----------|-------------------------------|-------|---|----------------------------|--|
| 1 | Drive Power | Green | The power is turned on, and the drive is operating normally. | Drive I/O is taking place. | The power is turned off. |
| 2 | Drive Service Action Required | Amber | An error has occurred. | | Normal status. |
| 3 | Drive Service Action Allowed | Blue | The drive canister can be removed safely from the drive tray. | | The drive canister cannot be removed safely from the drive tray. |

Things to Know – Service Action Allowed LEDs

Each controller canister, power-fan canister, and battery canister has a Service Action Allowed LED. The Service Action Allowed LED lets you know when you can remove a canister safely.



ATTENTION Possible loss of data access – Never remove a controller canister, a power-fan canister, or a battery canister unless the appropriate Service Action Allowed LED is on.

If a controller canister or a power-fan canister fails and must be replaced, the Service Action Required (Fault) LED on that canister comes on to indicate that service action is required. The Service Action Allowed LED also comes on if it is safe to remove the canister. If data availability dependencies exist or other conditions that dictate a canister should not be removed, the Service Action Allowed LED stays off.

The Service Action Allowed LED automatically comes on or goes off as conditions change. In most cases, the Service Action Allowed LED comes on when the Service Action Required (Fault) LED comes on for a canister.



NOTE If the Service Action Required (Fault) LED comes on but the Service Action Allowed LED is off for a particular canister, you might need to service another canister first. Check your storage management software to determine the action that you should take.

Hardware Cabling

This document provides conceptual and procedural information for cabling various combinations of the components that make up a storage array.

Controller trays:

- CE7922 controller tray
- CE7900 controller tray
- CE6998 controller tray
- CE6994 controller tray

Controller-drive trays:

- CE5400 controller-drive tray
- CE4900 controller-drive tray
- CDE3994 controller-drive tray
- CDE3992 controller-drive tray
- CE2600 controller-drive tray
- CE2600-60 controller-drive tray

Drive trays:

- DE6900 drive tray
- DE6600 drive tray
- FC4600 drive tray
- AT2655 drive tray
- FC2610 drive tray
- FC2600 drive tray
- DE5600 drive tray
- DE1600 drive tray

This document also describes host cabling and cabling for out-of-band management.

This document is intended for system operators, system administrators, and technical support personnel who are responsible for the installation and the setup of the storage array. Users must be familiar with basic computer system operations. In addition, they should understand disk storage technology, Redundant Array of Independent Disks (RAID) concepts, networking, and Fibre Channel technologies. Some models support SAS, iSCSI and InfiniBand technologies. The reader must have a basic knowledge of storage area network (SAN) hardware functionality (controllers, drives, and hosts) and SAN cabling.

For information related to the products mentioned in this document, go to http://www.lsi.com/storage_home/products_home/external_raid/index.html.

From the LSI Technical Support website, you can find contact information, query the knowledge base, submit a service request, download patches, or search for documentation. Visit the LSI Technical Support website at <http://www.lsi.com/support/index.html>.

Cabling Concepts and Best Practices

This chapter has three sections:

- The first section, “[Cabling Concepts](#),” provides definitions of the terms used in this document. This section is intended primarily for reference. Read the entire section to increase your overall understanding of the storage array and help you to optimize your storage array.
- The second section, “[Best Practices](#),” contains information that might affect your choice of cabling topologies. Read this section to understand the options for cabling your storage array.
- The third section, “[Common Procedures](#)” contains procedures that you will need to perform while you are cabling the storage array. Read this section to understand tasks that might be required to cable your storage array.

Cabling Concepts

This section defines terms and concepts that are used in this document.

Fabric (Switched) Topologies Compared to Direct-Attach Topologies

Fabric topologies use a switch. Direct-attach topologies do not use a switch. A switched topology is required if the number of hosts to connect to a controller tray or controller-drive tray is greater than the number available host ports on the tray.

Host connections might be InfiniBand, Fibre Channel, iSCSI, or a mix of Fibre Channel and iSCSI. Switches must support the required connection type or types. A combination of switches of different types might be appropriate for some configurations that support a mixture of connection types.

Drive Tray

A drive tray contains drives but no controllers. Drive trays usually are attached to either a controller tray or a controller-drive tray so that the controller in the controller tray or the controller-drive tray can configure, access, and manage the storage space in the drive tray. Drive trays can be differentiated by type, which are described in the following subsections.

Switched Bunch of Disks

Switched Bunch of Disks (SBOD) is a device that takes all of the drives that are operating in a single Fibre Channel-Arbitrated Loop (FC-AL) segment and provides each drive with access to one or more controllers in a point-to-point fashion. This action is accomplished in a way that appears to be compliant with the FC-AL-2 protocol. As a result, system firmware changes are not required.

In this document, the FC2610 drive trays and the FC4600 drive trays are referred to as SBODs in the cabling diagrams. The AT2655 drive trays are identified as SATA (Serial Advanced Technology). The following figure shows an example of this type of labeling for drive trays. The DE6900 drive trays and DE6600 drive trays The DE6900 drive trays are SBODs and can be mixed only with FC4600 drive trays. Do not mix FC2600 drive trays with other types of drive trays on the same loop.

SBOD Labeling in Cabling Diagrams

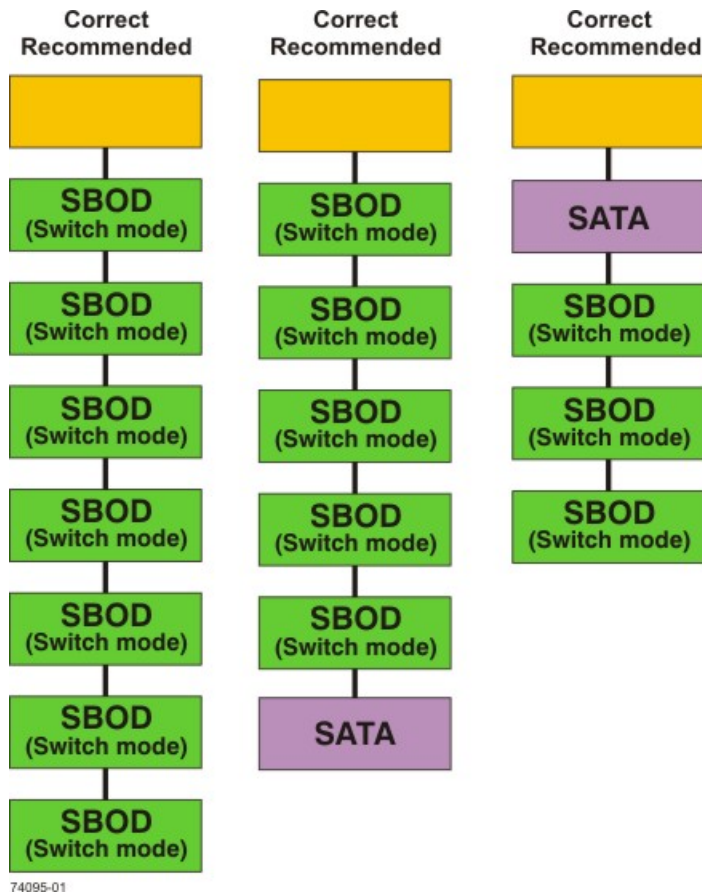

Controller Tray

A controller tray contains controllers. A controller tray does not contain drives. Controller trays configure, access, and manage the storage space of attached drive trays.

Controller-Drive Tray

A controller-drive tray contains both controllers and drives. The controllers configure, access, and manage the storage space of the drives in the controller-drive tray. A controller-drive tray might configure, access, and manage the storage space of other attached drive trays, depending upon the model.

Host Channels and Drive Channels

In this document, the term *channel* refers to a path for the transfer of data information and control information between the host and the controller, or between the drive trays and the controller trays or controller-drive trays. A data path from a host to a controller is a *host channel*. A host channel might be Fibre Channel, InfiniBand, iSCSI, or Serial Attached SCSI (SAS). A path from a drive trays to a controller trays or a controller-drive trays is a *drive channel*. Each drive channel is defined by a single Fibre Channel-Arbitrated Loop or by a series of SAS devices connected through expanders. Controllers have between two and eight available host channels, and between one and eight available drive channels, depending upon the model. The maximum number of hosts per host channel and the maximum number of drives per drive channel depends upon the model. For model-specific information, see the topics under "[Product Compatibility](#)."



NOTE When you mix different types of drive trays, you must consider the total number of drives that are available in the final configuration of the storage array. For example, if you mix FC4600 drive trays with FC2610 drive trays, the total number of drives might be more than the maximum number that each drive channel can support.

Host Ports and Drive Ports

The ports are the physical connectors on the controller tray or the controller-drive tray that, along with the cabling, enable the transfer of data. If the port communicates with the host server, it is a *host port*. If the port communicates with a drive tray, it is a *drive port*. The figures in the topics under "Component Locations" show the connectors on the rear of each of the various trays. These figures will help you differentiate between host ports and drive ports.

Dual-Ported Drives

Each drive in a controller-drive tray or a drive tray is dual ported. Circuitry in the drive tray or the controller-drive tray connects one drive port to one channel and the other port to another channel. Therefore, if one drive port or drive channel fails, the data on the drive is accessible through the other drive port or drive channel.

SATA drives are not dual ported; however, the electronics in the AT2655 drive tray emulate the behavior of dual-ported drives. Each SATA drive is available through two paths.

Preferred Controllers and Alternate Controllers

The preferred controller is the controller that "owns" a volume or a volume group. SANtricity ES Storage Manager automatically selects the preferred controller when a volume is created, or the user can override the default selection.

Several conditions will force the preferred controller to fail over to the alternate controller. When this event occurs, ownership of the volume is shifted to the alternate controller. These conditions might initiate failover:

- The preferred controller is physically removed.
- The preferred controller is being updated with new firmware.
- The preferred controller has sustained a fatal event.

The paths used by the preferred controller to access either the drives or the host are called the preferred paths, and the redundant paths are the alternate paths. If a failure occurs that causes the preferred path to become inaccessible, the alternate path software detects the failure and automatically switches to the alternate path.

Alternate Path Software

Alternate path software or an alternate path (failover) driver is a software tool that provides redundant data path management between the host bus adapter (HBA) and the controller. This tool is installed on the host in a system that provides redundant HBAs and paths. The tool discovers and identifies multiple paths to a single logical unit number (LUN) and establishes a preferred path to that LUN. If any component in the preferred path fails, the alternate path software automatically reroutes input/output (I/O) requests to the alternate path so that the system continues to operate without interruption.

To learn how alternate path software works with SANtricity ES Storage Manager features to provide data path protection, refer to the topics under *Concepts* or the corresponding PDF document on the SANtricity ES Storage Manager Installation DVD.

Failover

Failover is an automatic operation that switches from a failed component or failing component to an operational component. In the case of a Redundant Array of Independent Disks (RAID) controller failover, an operational controller takes over the ownership of volumes. The operational controller processes I/O from the host in place of the failing component or failed controller. Controller failover is possible only in controller trays or in controller-drive trays that contain two controllers.

In a system in which the alternate path software tool is installed on the host, the data paths through the failed HBA are replaced by data paths through the surviving HBA.

For more information, refer to the topics under *Failover* or to the corresponding PDF on the SANtricity ES Storage Manager Installation DVD.

Redundant and Non-Redundant

The term *redundant* indicates the existence of something more than what is essential to accomplish a task. In storage area network technology, redundancy means that essential services are implemented using duplicated components in such a way that if one component fails an alternative component continues to provide the service. This redundancy ensures the availability of data in case a component fails.

In most RAID systems, most of the components are redundant, but that the system might not be fully redundant. In other words, there might be one or two components whose individual failures would cause loss of access to data. Therefore, a *fully redundant system* duplicates all components and is configured to make sure that the duplicate components can be accessed in case of a failure. The manner in which the system is cabled is an essential component of creating a successfully configured redundant system.

Single Point of Failure

Any component or path that is not duplicated (redundant) or whose failure can cause loss of data access is called a potential *single point of failure*. The cabling scenarios in this document note the components that present a potential single point of failure. Choose a cabling topology that does not create a single point of failure.

SFP Transceivers, Fiber-Optic Cables, and Copper Cables

Controller-drive trays, controller trays, and drive trays use fiber-optic cables or copper cables for Fibre Channel connections. For copper Fibre Channel cables, a passive copper Small Form-factor Pluggable (SFP) transceiver is attached to each end of the cable. InfiniBand connections are made with fiber-optic cables. If your system will be connected with Fibre Channel or InfiniBand fiber-optic cables, you must install an active SFP transceiver into each port in which a fiber-optic cable will be connected before plugging in the fiber-optic cable. Connections for 10-Gb/s iSCSI require SFP transceivers. Connections for 1-Gb/s iSCSI use copper cables with RJ-45 connectors and do not require SFP transceivers. Connections for SAS use copper cables with SFF 8088 connectors and do not require SFP transceivers. The following figures show the two types of cables that use SFP transceivers. Note that your SFP transceivers and cables might look slightly different from the ones shown. The differences do not affect the performance of the SFP transceivers.



WARNING (W03) Risk of exposure to laser radiation – Do not disassemble or remove any part of a Small Form-factor Pluggable (SFP) transceiver because you might be exposed to laser radiation.

Active SFP Transceiver with Fiber-Optic Cable

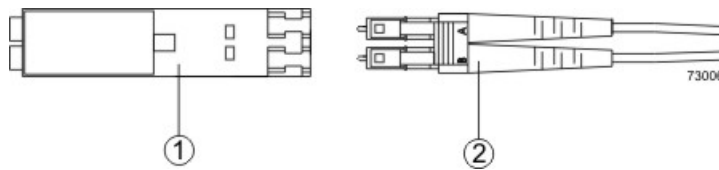

1. Active SFP Transceiver
2. Fiber-Optic Cable

Passive SFP Transceiver with Copper Cable

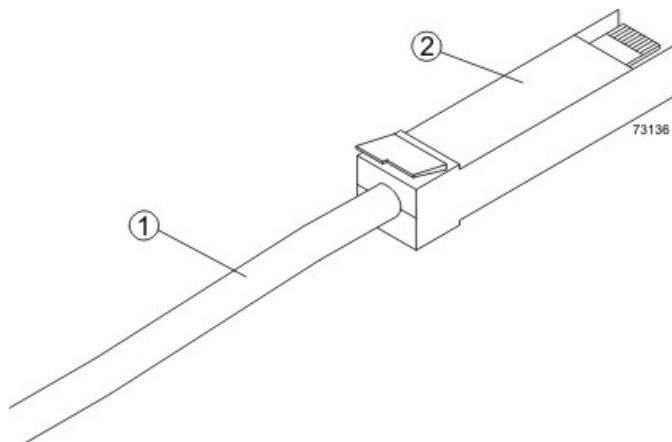

1. Copper Cable
2. Passive SFP Transceiver

Host Adapters

Each connection from a host port on a controller tray or a controller-drive tray to a host is made through a host adapter on the host. A host adapter can be a host bus adapter (HBA) for Fibre Channel or SAS connections, a host channel adapter (HCA) for InfiniBand connections, or an Ethernet adapter for iSCSI connections. The host adapter provides the interface to the internal bus of the host. For hardware redundancy, use two host adapters in each host computer. The two host adapters must be of the same type (HBAs, HCAs, or Ethernet). For duplex controller trays or duplex controller-drive trays, connect each host adapter to a different controller in a controller tray or a controller-drive tray to make sure that the server will be accessible even if one HBA or one controller fails.

⚠ ATTENTION Possible loss of data access – Do not use a combination of HBAs from different vendors in the same storage area network (SAN). For the HBAs to perform correctly, use HBAs from only one manufacturer in a SAN.

You can obtain information about supported host adapters from the Compatibility Matrix. To check for current compatibility, refer to the Compatibility Matrix at <http://www.lsi.com/compatibilitymatrix/>, and click the **Compatibility Matrix** link.

Host Interface Cards

Each controller in a CE7900 controller tray has one or two host interface cards (HICs) that contain the host ports. Each controller in a CE4900 controller-drive tray has two Fibre Channel host ports built in, as well as an optional HIC for additional host ports. Each controller in a CE2600 controller-drive tray or a CE2600-60 controller-drive tray has two SAS host ports built in, as well as an optional HIC for additional host ports.

An HIC is cabled to a host adapter: a host bus adapter (HBA) for Fibre Channel or SAS, a host channel adapter (HCA) for InfiniBand, or an Ethernet adapter for iSCSI. The host adapter in the host must match the type of HIC to which it is cabled.

Network Interface Cards

A network interface card (NIC) is an expansion board that is installed in the host server. Some servers are equipped with an integrated NIC. The NIC supports Ethernet technology. The NIC is required for network communication. Each Ethernet cable connection for out-of-band storage array management is made through a NIC (see the topics under [In-Band Management and Out-of-Band Management](#)).



NOTE It is the responsibility of the customer to obtain the required NICs and to install them.

Switches and Zoning

A switch is an intelligent device that connects multiple devices. A switch allows data transfer between the devices, depending upon the designated source (*initiator*) and the destination (*target*) of the data. Switches can redirect traffic to ports other than the designated destination, if necessary. A switch provides full bandwidth per port and high-speed routing of data.

Zoning allows a single hardware switch to function as two or more virtual switches. In a zoned configuration, communication among devices in each zone is independent of communication among devices in another zone or zones. Zoned switches allow an administrator to restrict access to specific areas within a storage area network (SAN).

How Initiators and Targets Respond to Zoning

When an initiator first accesses the fabric, it queries the World Wide Identifier (WWID) name server for all of the attached disks and drive trays and their capabilities. Zoning is like a filter that the WWID name server applies to the query from the initiator that limits the information returned by the WWID name server to the initiator. A zone defines the WWID of the initiator and the WWID of the devices that a particular zone is allowed to access. Devices that are not part of the zone are not returned as accessible devices.

The fabric provides universal access for all initiators and targets. Any initiator can query (probe) the fabric for all targets, which can affect performance when many targets are connected to the fabric. The querying process also provides access to devices for which access is not needed. Use zoning to limit the number of devices that an initiator can access. Within your storage area network, you should zone the fabric switches so that the initiators do not “see” or communicate with each other.

How Best to Approach Zone Configuration

Some of the cabling topologies shown in this document require the use of a zoned switch. By default, the switch uses no zoning, which is not sufficiently robust for most applications. You must configure the switch before you use it.

Zone configuration is managed on a per-fabric basis. While you can administer zone configuration from any switch, use the best practice of selecting one switch for all zone administration. Give preference to the primary switches within the SAN, and choose only a switch that has the most up-to-date storage management software and switch management software installed on it.

In-Band Management and Out-of-Band Management

A system administrator manages a storage array from a storage management station, which is a workstation on which the SANtricity ES Storage Manager Client is installed. Requests and status information sent between the storage array and the storage management station are managed in one of two ways: in-band or out-of-band. A storage array that uses out-of-band management requires a different network topology from a storage array that uses in-band management.

When you use *in-band management*, a SANtricity ES Storage Manager agent running on the host receives requests from the management station. The host agent processes the requests through the host I/O interface to the storage array. The host I/O interface might be Fibre Channel, serial-attached Small Computer System Interface (SAS), InfiniBand, or Internet SCSI (iSCSI).

Example of In-Band Management Topology

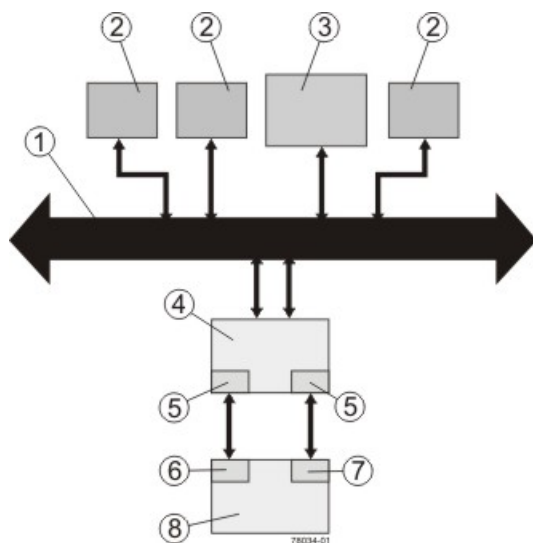

1. Ethernet Network
2. User Workstations Sending and Receiving Data
3. Storage Management Station
4. Host
5. Host Adapters
6. Controller A
7. Controller B
8. Controller Tray or Controller-Drive Tray for the Storage Array

When you use *out-of-band management*, the storage management station is connected, through an Ethernet network, to each of the controllers in the controller tray or the controller-drive tray.

Example of Out-of-Band Management Topology

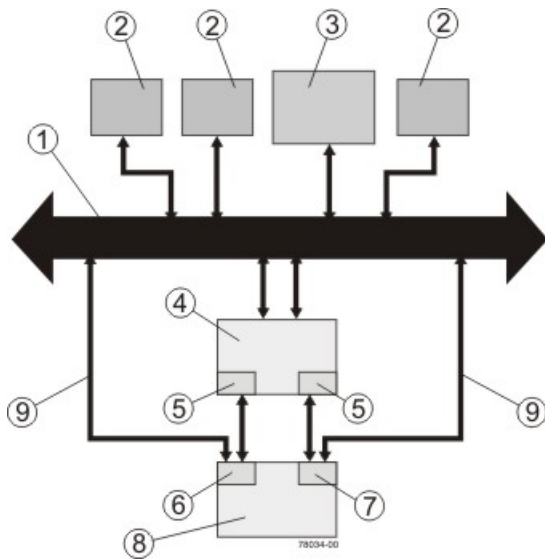

1. Ethernet Network
2. User Workstations Sending and Receiving Data
3. Storage Management Station
4. Host
5. Host Adapters
6. Controller A
7. Controller B
8. Controller Tray or Controller-Drive Tray for the Storage Array
9. Ethernet Cable from the Controllers to the Ethernet Network

When using out-of-band management, a Dynamic Host Configuration Protocol (DHCP) server is recommended for assigning Internet Protocol (IP) addresses and other network configuration settings. A DHCP server provides the network administrators the ability to manage and automatically assign IP addresses. If a DHCP server is not used, you must manually configure the controllers. For more information, refer to the Adding a Host or Storage Array online help topic in the Enterprise Management Window.



ATTENTION Risk of unauthorized access to or loss of data – If the out-of-band management method is used, connect the Ethernet ports on the controller tray or the controller-drive tray to a private network segment behind a firewall. If the Ethernet connection is not protected by a firewall, your storage array might be at risk of being accessed from outside of your network.



NOTE Where two Ethernet ports are available on each controller (four total), you can use one of the ports on each controller for out-of-band Ethernet connections. Reserve the second Ethernet port on each controller for access by your Customer and Technical Support representative.

For information about how to create a redundant out-of-band topology, see the topics under [Drive Cabling](#).

Best Practices

This section explains recommended cabling practices. To make sure that your cabling topology results in optimal performance and reliability, familiarize yourself with these best practices.



NOTE If your existing storage array cabling does not comply with the best practices described in this section, do not re-cable your storage array unless specifically requested to do so by your Customer and Technical Support representative.

Drive Cabling for Redundancy

When attaching the drive trays, use a cabling topology that does not create a single point of failure. A single point of failure might appear as a drive tray failure or another component failure in the middle of a grouping of drive trays. If a drive tray fails, you can no longer access the drive trays beyond the point of failure. By creating an alternate path, you make sure that the drive trays are accessible in the event of a drive tray failure.

The following figure shows a typical cabling scenario. In this example, each of the eight drive trays has two connections directly to the controller tray: one from ESM A to controller A and one from ESM B to controller B. Each redundant path pair on the controller tray connects to one drive tray. The ESM 1B ports are used for all of the connections.

Cabling for Eight Drive Trays

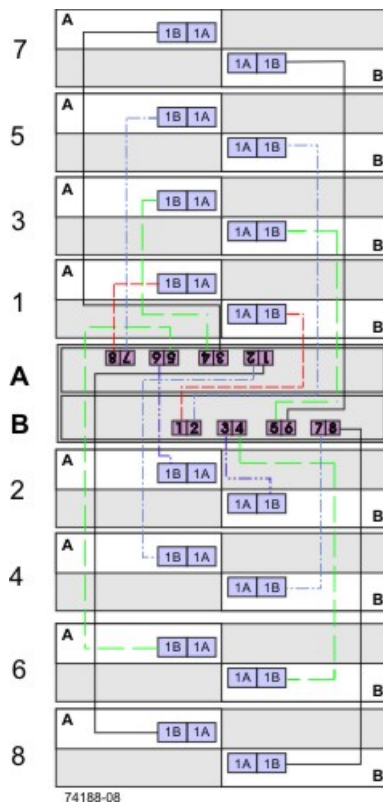

Note how the controller tray (denoted by A and B in the figure) is conveniently situated in the middle of the arrangement, which enables you to use cables that are all the same length. Positioning the controller tray near the middle of the cabinet also helps prevent the cabinet from becoming top heavy as drive trays are added.

For cabling examples, ranging from simple to complex, see the topics under [Drive Cabling](#).

Host Cabling for Redundancy

To ensure that, in the event of a host channel failure, the storage array will stay accessible to the host, establish two physical paths from each host to the controllers, and install alternate path software on the host. This cabling topology, when used with alternate path software, makes sure that a redundant path exists from the host to the controllers.



ATTENTION Possible loss of data access – You must install alternate path software or an alternate path (failover) driver on the host to support failover in the event of an HBA failure or a host channel failure.

For examples of redundant topologies, see the topics under [Host Cabling](#).

Host Cabling for Remote Volume Mirroring

The Remote Volume Mirroring premium feature provides online, real-time replication of data between storage arrays over a remote distance. In the event of a disaster or a catastrophic failure at one storage array, you can promote a second storage array to take over responsibility for computing services. See the topics under [Hardware Installation for Remote Volume Mirroring](#) for detailed information about cabling for Remote Volume Mirroring.

The Remote Volume Mirroring premium feature requires a dedicated host port for mirroring data between storage arrays. After the Remote Volume Mirroring premium feature has been activated, one host I/O port on each controller is solely dedicated to mirroring operations.



NOTE One of the host ports on *each* controller must be dedicated for the communication that occurs between the two storage arrays (primary volumes and secondary volumes). If you are not using the Remote Volume Mirroring premium feature, these host ports are available for ordinary host connections.

Cabling for Performance

Generally speaking, performance is enhanced by maximizing bandwidth, which is the ability to process more I/O across more channels. Therefore, a configuration that maximizes the number of host channels and the number of drive channels available to process I/O will maximize performance. Of course, faster processing speeds also maximize performance.

The DE6900 drive tray supports drive-side trunking. You can use drive-side trunking with the appropriate cabling configuration to, potentially, double the bandwidth available by making two drive channels simultaneously available to the same drive tray or loop.

In addition to planning a topology that provides maximum performance, choose a RAID level that suits the planned applications. For information on RAID levels, refer to the topics under *Concepts* or to the corresponding PDF document on the SANtricity ES Storage Manager Installation DVD.

Fibre Channel Drive-Side Trunking

Drive trays that support drive-side trunking can be cabled to a controller tray through a cabling pattern that doubles the bandwidth available to the drive trays. Trunking is possible only with drive trays that have Fibre Channel switch on a chip (SoC) loop-switch technology.

Drive-side trunking is an important feature for high-density drive trays because it enables a configuration with fewer drive trays connected to a controller tray to take advantage of the maximum bandwidth available for drive connections. For example, a storage array consisting of four DE6900 drive trays connected using

drive-side trunking to a CE7900 controller tray with two controllers can take advantage of all of the available bandwidth on the controller tray. Without drive-side trunking, the four drive trays can only use half of the available bandwidth.

Each environmental services monitor (ESM) on a drive tray that is capable of drive-side trunking has four ports. In the previous example, two ports on each ESM would connect to each of two ports of a dual-ported drive channel on the controller tray. A new drive tray could be added to the example configuration by cabling two ports on each ESM of the new drive tray to the two available ports on each ESM of one of the existing drive trays. The new drive tray would then share Fibre Channel loops with the drive tray to which it is cabled.

Considerations for Drive Channel Speed

When you connect multiple drive trays to the same drive channel, all of the drive trays must operate at the same speed. If you plan to combine drive trays that operate at different speeds on the same drive channel, you must set all of the drive trays to operate at the lowest common speed. The following table lists the operating speeds of each supported drive tray.

Specifications for the Drive Trays

| Model | Port Speed | Drives per Tray | Maximum Number of Drive Trays per Loop |
|-------------------|------------|-----------------|--|
| FC4600 drive tray | 4 Gb/s | 16 | 7 |
| FC2610 drive tray | 2 Gb/s | 14 | 8 |
| AT2655 drive tray | 2 Gb/s | 14 | 8 |
| DE6900 drive tray | 4 Gb/s | 60 | 2 |
| DE6600 drive tray | 6 Gb/s | 60 | 15 |
| DE5600 drive tray | 6 Gb/s | 24 | 7 |
| DE1600 drive tray | 6 Gb/s | 12 | 15 |

Multiple Types of Drive Trays

 **NOTE** Before you create a topology that combines multiple models of drive trays, make sure that your controller tray or controller-drive tray supports this feature. You must configure the controller tray or controller-drive tray to support multiple models of drive trays.

You can combine multiple drive tray models in a single storage array topology. Keep the following rules and guidelines in mind when you plan to cable your storage array with more than one drive tray type:

- To achieve maximum throughput performance, distribute drive trays across redundant drive channels in a controller tray or a controller-drive tray.
- Configure FC2610 drive trays and FC4600 drive trays (SBODs) in series as described in [Cabling for Drive Trays That Support Loop Switch Technology](#).
- Do not create multiple series of FC2610 drive trays and FC4600 drive trays (SBODs) that are separated by AT2655 SATA drive trays.

- Whenever possible, and with consideration of the previously stated rules and guidelines, place all like drive trays on the same drive channel.
- When you cable drive trays to a CE7900 controller tray, do not mix multiple types of drive trays on the same loop.
- Cable only DE1600 drive trays and DE5600 drive trays to a CE2600 controller-drive tray.
- Cable only DE1600 drive trays, DE5600 drive trays, and DE6600 drive trays to a CE5400 controller-drive tray. CE5400 controller-drive trays include the CE5400-12, CE5400-24, and CE5400-60 models.
- Do not exceed the maximum number of drives that a storage array can support. When you cable drive trays to a controller-drive tray, keep in mind that the drives installed in the controller-drive tray count toward the maximum number of drives.
- Do not cable more than 16 drive trays of any type to a CE5400 controller-drive tray.

The following tables summarizes the supported combinations of controller trays or controller-drive trays with drive trays.

Drive Tray Cabling Combinations for the CE7922, CE7900, CE6998, and CE6994 Controller Trays

| | DE6900 Drive Tray | FC4600 Drive Tray | AT2655 Drive Tray | FC2610 Drive Tray | FC2600 Drive Tray |
|-------------------------------|--|--|-------------------|-------------------|-------------------|
| CE7922 Controller Tray | <ul style="list-style-type: none"> ▪ Up to two per loop pair; eight per controller tray ▪ Mixing drive tray types is not supported | Up to seven per loop pair; 28 per controller tray | Not supported | Not supported | Not supported |
| CE7900 Controller Tray | <ul style="list-style-type: none"> ▪ Up to two DE6900 drive trays per loop pair; eight per controller tray ▪ Up to seven FC4600 drive trays per loop pair; 28 per controller tray ▪ When mixing FC4600 and DE6900 drive trays on the same loop, only one DE6900 drive tray and up to three FC4600 drive trays can share a loop. | | Not supported | Not supported | Not supported |
| CE6998 Controller Tray | Not supported | <ul style="list-style-type: none"> ▪ Up to seven FC4600 drive trays per channel; up to 14 per controller tray | | | |

| | DE6900 Drive Tray | FC4600 Drive Tray | AT2655 Drive Tray | FC2610 Drive Tray | FC2600 Drive Tray |
|---------------------------------------|------------------------------|---|------------------------------|------------------------------|------------------------------|
| CE6994 Controller Tray | Not supported | <ul style="list-style-type: none"> ▪ Up to eight AT2655, FC2610, or FC2600 drive trays per channel; up to 16 per controller tray ▪ When a channel has a mixture of FC4600, AT2655, FC2610, or FC2600 drive trays, up to seven drive trays per channel; up to 14 drive trays per controller tray ▪ When a controller tray has a mixture of FC4600, AT2655, FC2610, or FC2600 drive trays but each channel has only one type of drive tray, up to seven drive trays for each channel with FC4600 drive trays, up to eight drive trays for each channel with other drive tray types | | | |

Drive Tray Cabling Combinations for the CE4900, CDE3994, and CDE3992 Controller-Drive Trays

| | DE6900 Drive Tray | FC4600 Drive Tray | AT2655 Drive Tray | FC2610 Drive Tray | FC2600 Drive Tray |
|---|------------------------------|--|------------------------------|------------------------------|------------------------------|
| CE4900 Controller- Drive Tray | Not supported | Up to six per controller-drive tray | Not supported | Not supported | Not supported |
| CDE3994 Controller- Drive Tray | Not supported | <ul style="list-style-type: none"> ▪ Up to seven attached drive trays if no drives are in the controller-drive tray ▪ Up to six attached drive trays if no drives are in the controller-drive tray | | | |
| CDE3992 Controller- Drive Tray | Not supported | <ul style="list-style-type: none"> ▪ Mixing different drive tray types on the same loop is supported | | | |

Drive Tray Cabling Combinations for the CE5400 and CE2600 Controller-Drive Trays

| | DE1600 Drive Trays | DE5600 Drive Trays | DE6600 Drive Trays |
|--|--|--|--|
| CE5400-60 Controller-Drive Tray Standard Configuration | Up to 15 per controller-drive tray when the controller-drive tray contains 60 drives | Up to twelve per controller-drive tray when the controller-drive tray contains 60 drives | Up to five per controller-drive tray when the controller-drive tray contains 60 drives |
| CE5400-24 Controller-Drive Tray Standard Configuration | Up to 15 per controller-drive tray when the controller-drive tray contains 24 drives | Up to 15 per controller-drive tray when the controller-drive tray contains 24 drives | Up to six per controller-drive tray when the controller-drive tray contains 24 drives |
| CE5400-12 Controller-Drive Tray Standard Configuration | Up to 15 per controller-drive tray when the | Up to 15 per controller-drive tray when the | Up to six per controller-drive tray when the |

| | DE1600 Drive Trays | DE5600 Drive Trays | DE6600 Drive Trays |
|--|--|---|---|
| | controller-drive tray contains 12 drives | controller-drive tray contains 12 drives | controller-drive tray contains 12 drives |
| CE5400-60 Controller-Drive Tray High Performance Coomputing Configuration | Up to 15 per controller-drive tray when the controller-drive tray contains 60 drives | Up to seven per controller-drive tray when the controller-drive tray contains 60 drives | Up to three per controller-drive tray when the controller-drive tray contains 60 drives |
| CE5400-24 Controller-Drive Tray High Performance Coomputing Configuration | Up to 15 per controller-drive tray when the controller-drive tray contains 24 drives | Up to nine per controller-drive tray when the controller-drive tray contains 24 drives | Up to three per controller-drive tray when the controller-drive tray contains 24 drives |
| CE5400-12 Controller-Drive Tray High Performance Coomputing Configuration | Up to 15 per controller-drive tray when the controller-drive tray contains 12 drives | Up to nine per controller-drive tray when the controller-drive tray contains 12 drives | Up to three per controller-drive tray when the controller-drive tray contains 12 drives |
| CE2600-60 Controller-Drive Tray | Not supported | Not supported | Up to two per controller-drive tray |
| CE2600-24 Controller-Drive Tray | Up to 15 per controller-drive tray | Up to seven per controller-drive tray | Not supported |
| CE2600-12 Controller-Drive Tray | Up to 16 per controller-drive tray | Up to eight per controller-drive tray | Not supported |

Single-Controller Topologies and Dual-Controller Topologies

If you are creating a topology for a controller tray or a controller-drive tray that contains only one controller, you can attach only drive trays that contain a single environmental services monitor (ESM). Do not attach a drive tray that contains two ESMs to a single-controller controller tray or a single-controller controller-drive tray.

Copper Cables and Fiber-Optic Cables

You can use a combination of copper cables and fiber-optic cables to connect the drive trays to a controller tray or to a controller-drive tray. However, when a drive tray communicates with the controller tray (or the controller-drive tray) indirectly, through another drive tray, the connections between the drive tray and the controller tray (or the controller-drive tray) and between the two drive trays must use the same type of cable. Fiber-optic cables are required for host connections.

Cabling for Drive Trays That Support Loop Switch Technology

The FC2610 drive trays and the FC4600 drive trays operate internally as an array of drives that are connected in a point-to-point configuration by a Fibre Channel-Arbitrated Loop (FC-AL) loop switch. These drive trays are referred to as a Switched Bunch of Disks (SBOD). Drive trays without loop switch support operating as a string of drives on an arbitrated loop. SBOD drive trays operate more reliably than drive trays that use a traditional loop configuration. The loop switch also reduces transfer latency, which can increase performance in some configurations. To operate in Switch mode, you must cluster SBOD drive trays together when they are combined with other types of drive trays in a storage array topology.

The SBOD drive trays operate in *Switch mode* either when an SBOD drive tray is connected singly to a controller tray or a controller-drive tray, or when multiple SBOD drive trays are connected in series to a controller tray or a controller-drive tray. An SBOD drive tray operates in *Hub mode* when a single SBOD drive tray is connected in series with other drive trays that do not support a loop switch. The SBOD drive trays also operate in *Hub mode* when multiple SBOD drive trays are interspersed in series with other drive trays that do not support a loop switch. The SBOD drive tray does not take advantage of the internal switch technology when operating in Hub mode. Some statistics that are available in switch mode are not available in Hub mode.

If SBOD drive trays are not clustered together correctly, the SANtricity ES Storage Manager software shows a Needs Attention status for the SBOD drive trays. A Needs Attention status does not prevent the SBOD drive trays from processing data; however, the Needs Attention status persists until you change the cabling topology. To maximize the performance of SBOD drive trays, always cable the SBOD drive trays in a series.

The following figure shows a simple block diagram of three recommended topologies for SBOD drive trays. All three scenarios shown in the figure are arranged to maximize performance. The scenario on the left of the figure (all SBODs) also offers the advantage of flexible drive cabling; for example, connecting two In ports or two Out ports. This flexible approach to drive cabling is enabled by the FC-AL feature.

In the figure, the FC2610 drive trays or the FC4600 drive trays are identified as SBODs. The AT2655 drive trays are identified as SATA (Serial Advanced Technology Attachment).



NOTE When you connect drive trays to the CE7922 controller tray or the CE7900 controller tray, you must not mix different types of drive trays on the same loop.



NOTE When you mix different types of drive trays, you must consider the total number of drives that are available in the final configuration of the storage array. For example, if you mix FC4600 drive trays with FC2610 drive trays, the total number of drives might be more than the maximum number that each drive channel can support.

Suitable Cabling Topologies for Multiple SBOD Drive Trays

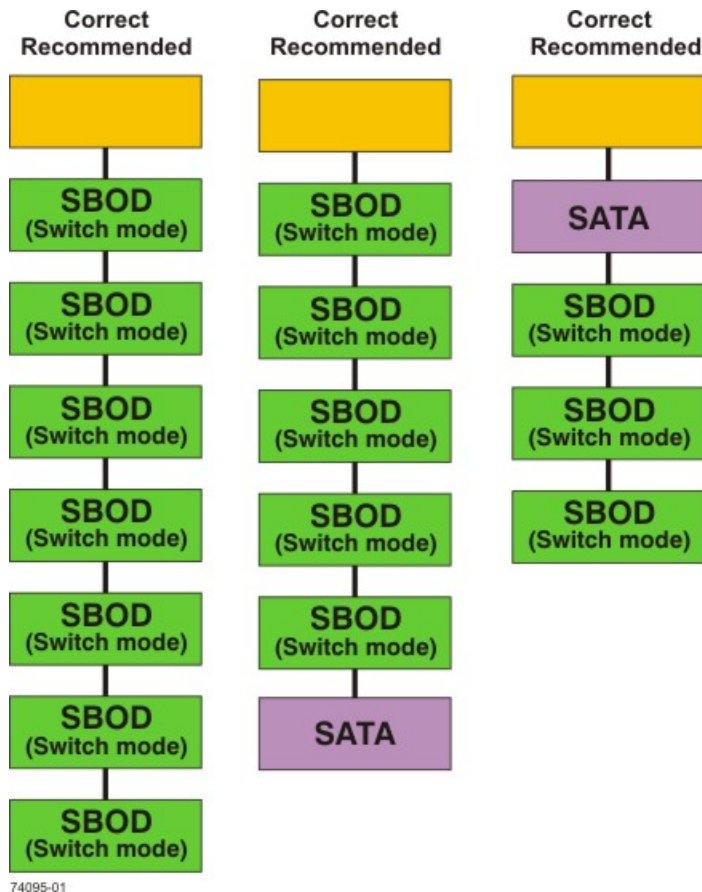

Labeling Cables

Cabling is an important part of creating a robust storage array. Labeling the cables identifies system components, drive channels, and loops. System maintenance is easier when the cables are correctly identified. Label both ends of each cable. You can use adhesive office labels that are folded in half over the ends of each cable. Mark the labels with the port identifiers to which the cable is connected. If you use the recommended topologies in as described in the topics under [Host Cabling](#) and [Drive Cabling](#), label each cable with the channel number noted in the table that you are following. You can provide additional information by using color-coded cable straps (or ties) to group all of the cables associated with one component, drive channel, or loop.

If a component fails, you must disconnect the cables, replace the failed component, and reattach the cables. Detailed labeling of the cables will simplify the component replacement process.

If you add a new drive tray to an existing configuration, correctly labeled cables will help you identify where to connect the new drive tray.

Cabling Information Provided by SANtricity ES Storage Manager

After you have completed your cabling topology and installed the SANtricity ES Storage Manager software, you can view cabling information through the SANtricity ES Storage Manager software. The SANtricity ES Storage Manager software shows a table that lists all of the connections in the cabling topology and identifies any incorrectly cabled drive channels or non-redundant drive channels. For more information, refer to the online help topics in the SANtricity ES Storage Manager software.

Adding New Drive Trays to an Existing Storage Array

HotScale™ technology enables you to add drive trays to an existing storage array without interrupting power or data transfer to the storage array. See the topics under [Drive Cabling](#) for the recommended cabling patterns for various numbers of attached drive trays.

For non-SAS drive connections, when the number of drive trays exceeds the number of drive ports on a controller, the cabling pattern changes significantly. At this point, you will start to use the “A” ports on the ESMS, and additional drive trays connect to the controller tray indirectly, through other drive trays.

If you are adding additional drive trays to an existing non-SAS configuration so that the total number of attached drive trays will increase from fewer than the number of drive ports per controller to a total that is greater than that number, you will need to re-cable some of the drive trays that were previously installed.

Common Procedures

This section provides procedures that are common to most cable installations.

Handling Static-Sensitive Components

Static electricity can damage dual inline memory modules (DIMMs), system boards, and other static-sensitive components. To prevent damaging the system, follow these precautions:

- Move and store all components in the static-protective packaging in which they came.
- Place components on a grounded surface before removing them from their static-protective packaging. Grounded surfaces include static-dissipating mats or grounded workstations.
- Always be properly grounded when touching a static-sensitive component. To properly ground yourself, wear a wrist strap or boot strap made for this purpose.
- Handle the component by its edges. Do not touch solder joints, pins, or printed circuitry.
- Use conductive field service tools.

Installing an SFP Transceiver and a Fiber-Optic Cable

You must install SFP transceivers into each connector to which you will connect a fiber-optic cable.



ATTENTION Potential degraded performance – To prevent degraded performance, do not twist, fold, pinch, or step on the fiber-optic cables. Many cables have a minimum bending radius. For example, do not bend fiber-optic Fibre Channel cables tighter than a 5-cm (2-in.) radius. Check the specifications for your cables and do not bend any cable more tightly than the minimum specified radius.



ATTENTION Possible hardware damage – To prevent electrostatic discharge damage to the tray, use proper antistatic protection when handling tray components.

1. Put on antistatic protection.
2. Make sure that your cables are fiber-optic cables by comparing them to the fiber-optic cable shown in the following figure. Your SFP transceivers might look slightly different from the one shown. The differences do not affect the performance of the SFP transceiver.

SFP Transceiver and Fiber-Optic Cable

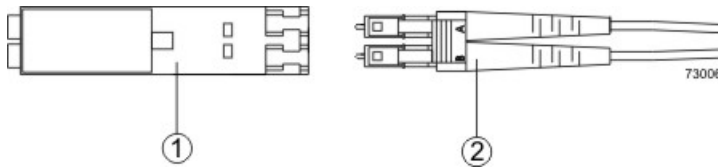

1. SFP Transceiver
2. Fiber-Optic Cable
3. Insert an SFP transceiver into the port in which the fiber-optic cable will be installed.



NOTE Make sure that the SFP transceiver installs with an audible click.

Installing an SFP Transceiver

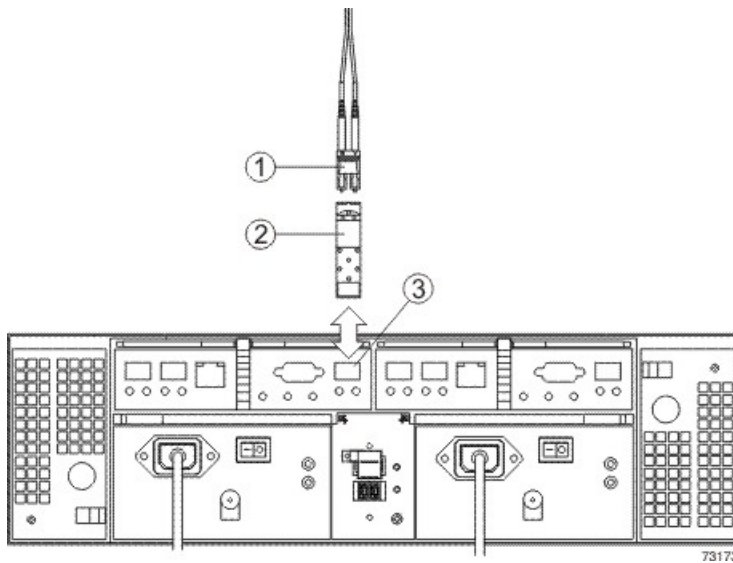

1. Fiber-Optic Cable
2. SFP Transceiver
3. Drive Tray Port
4. Install the fiber-optic cable.

Installing a Copper Cable with a Passive SFP Transceiver



ATTENTION Possible hardware damage – To prevent electrostatic discharge damage to the tray, use proper antistatic protection when handling tray components.

1. Put on antistatic protection.
2. Verify that your cables are copper cables by comparing them to the cable shown in the following figure. Your passive SFP transceivers might look slightly different from the one shown. The differences do not affect the performance of the SFP transceiver.

Passive SFP Transceiver and Copper Cable

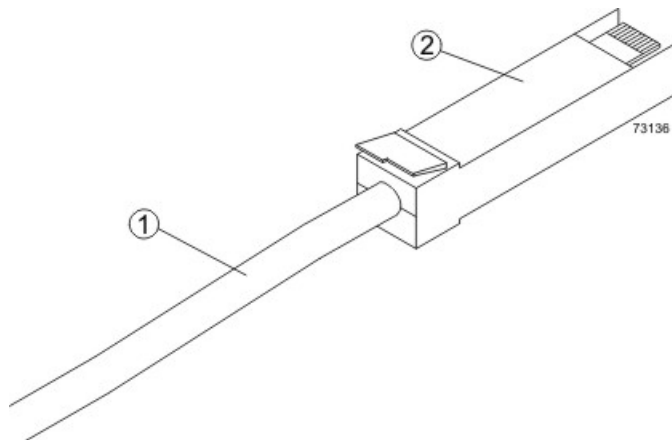

1. Copper Cable
2. Passive SFP Transceiver



NOTE Make sure that the passive SFP transceiver installs with an audible click.

3. Insert the passive SFP transceiver into the port in which the copper cable will be installed.

Installing an iSCSI Cable



ATTENTION Possible hardware damage – To prevent electrostatic discharge damage to the tray, use proper antistatic protection when handling tray components.

1. Put on antistatic protection.
2. Verify that you have the correct cables for an iSCSI connections by comparing them to the cable shown in the following figure. Cables for iSCSI connections do not require SFP transceivers.

iSCSI Cable with an RJ-45 Connector

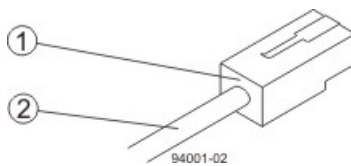

1. RJ-45 Connector
2. iSCSI Cable

3. For each cable, insert one RJ-45 connector into a host interface card port on the controller-drive tray or the controller tray and the other RJ-45 connector into a port on the host's Ethernet adapter.

Installing a SAS Cable



ATTENTION Possible hardware damage – To prevent electrostatic discharge damage to the tray, use proper antistatic protection when handling tray components.

1. Put on antistatic protection.
2. Verify that you have the correct cables for a SAS connections by comparing them to the cable shown in the following figure. Cables for SAS connections do not require SFP transceivers.

SAS Cable with an SFF-8088 Connector

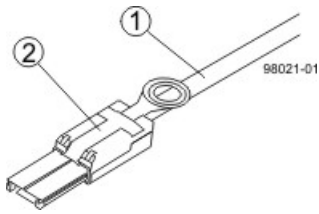

1. SAS Cable
2. SFF-8088 Connector
3. For each cable, insert one SFF-8088 connector into a host interface card port on the controller-drive tray or the controller tray and the other SFF-8088 connector into an port on the host's HBA.

Product Compatibility

This chapter lists all currently supported products, along with their host and drive channel specifications.

Host Channel Information by Model

The following table lists the specifications and restrictions that affect host-cabling topologies. Make sure that your planned controller tray topology or your planned controller-drive tray topology is compatible with these specifications and restrictions.

Host Channel Information for Controller Trays and Controller-Drive Trays

| Product | Host Port Type | Maximum Host Port Speed | Number of Host Ports per Controller | Maximum Number of Hosts per Cluster | Maximum Number of Hosts | Cable Type |
|--|----------------|---------------------------|-------------------------------------|-------------------------------------|-------------------------|----------------------------------|
| CE7922 controller tray | InfiniBand | 2 Gb/s 4 Gb/s | 0, 4, or 8 | 16 | 2048 | Copper or fiber-optic InfiniBand |
| CE7900 controller tray | Fibre Channel | 8 Gb/s (with 8-Gb/s HICs) | 0, 4, or 8 | 16 | 2048 | Fiber-optic |
| | iSCSI | 1 Gb/s 10 Gb/s | 0, 4, or 8 | 16 | 256 | Copper |
| | InfiniBand | 20 Gb/s | 0, 4, or 8 | 16 | 256 | Fiber-optic InfiniBand |
| CE6998 controller tray | Fibre Channel | 4 Gb/s | 4 | 16 | 1024 | Fiber-optic |
| CE5400-60, CE5400-24, and CE5400-12 controller-drive trays | Fibre Channel | 8 Gb/s | One or two quad-port adapters | 16 | 512 | Fiber-optic (Fibre Channel) |
| | InfiniBand | 40 Gb/s | Zero or one dual-port adapter | | | Fiber-optic InfiniBand |
| CE4900 controller-drive tray | Fibre Channel | 8 Gb/s | 2 or 4 | 16 | 640 | Fiber-optic |
| | iSCSI | 1 Gb/s 10 Gb/s | 2 | 16 | 640 | Copper |
| CDE3994 controller-drive tray | Fibre Channel | 2 Gb/s | 4 | 16 | 1024 | Fiber-optic |

| Product | Host Port Type | Maximum Host Port Speed | Number of Host Ports per Controller | Maximum Number of Hosts per Cluster | Maximum Number of Hosts | Cable Type |
|--|----------------|-------------------------|-------------------------------------|-------------------------------------|-------------------------|-------------|
| CDE3992 controller-drive tray | Fibre Channel | 2 Gb/s | 2 or 4 | 16 | 256 | Fiber-optic |
| CE2600 controller-drive tray and the CE2600-60 controller-drive tray | SAS | 6 Gb/s 10 Gb/s | 2 or 4 | 16 | 256 | Copper |
| | Fibre Channel | 8 Gb/s | 0 or 4 | 16 | 256 | Fiber-optic |
| | iSCSI | 1 Gb/s 10 Gb/s | 0 or 4 | 16 | 256 | Copper |

Drive Channel Information by Model

The following table lists the specifications and restrictions that affect cabling between controller trays and drive trays or between controller-drive trays and drive trays. Make sure that the topology you plan for your drive trays is compatible with these specifications and restrictions.

 **NOTE** When you mix different types of drive trays, you must consider the total number of drives that are available in the final configuration of the storage array. For example, if you mix FC4600 drive trays with FC2610 drive trays, the total number of drives might be more than the maximum number that each drive channel can support.

Drive Channel Information for Controller Trays and Controller-Drive Trays

| Product | Drive Port Speeds | Maximum Number of Drives | Supported Drive Trays | Cable Type | Notes |
|------------------------|-------------------|--------------------------|-----------------------|---|--|
| CE7922 controller tray | 2 Gb/s or 4 Gb/s | 480 | DE6900 FC4600 | Copper FC cables or fiber-optic FC cables | The 480 maximum number of drives is possible only for a configuration with eight DE6900 drive trays with no other types of drive trays. There is a limit of two expansion drive trays for each redundant pair of loops. Up to 448 drives are possible when FC4600 drive trays are used exclusively. There is a limit of seven expansion drive trays for each redundant pair of loops. Mixing drive types is not supported. |
| CE7900 controller tray | 2 Gb/s or 4 Gb/s | 480 | DE6900 FC4600 | Copper FC cables, fiber-optic | The 480 maximum number of drives is possible only for a configuration with eight DE6900 |

| Product | Drive Port Speeds | Maximum Number of Drives | Supported Drive Trays | Cable Type | Notes |
|---|-------------------|--------------------------|--------------------------------------|---|---|
| | | | | FC cables, or copper iSCSI cables | drive trays with no other types of drive trays. There is a limit of two expansion drive trays for each redundant pair of loops. Up to 448 drives are possible when FC4600 drive trays are used exclusively. There is a limit of seven expansion drive trays for each redundant pair of loops. Mixing drive tray types is supported. The maximum number of drives for a mixed configuration is 448. With a CE7900 controller tray, FC4600 drive trays support solid-state drives (SSDs). A drive tray can have both SSDs and hard disk drives. The maximum number of SSDs for the storage array is 20. |
| CE6998 controller tray and CE6994 controller tray | 2 Gb/s or 4 Gb/s | 224 | FC4600 AT2655 FC2610 FC2600 | Copper FC cables or fiber-optic FC cables | If you are using the FC4600 drive tray in your configuration, design for a limit of seven expansion drive trays for each redundant pair of loops. With the AT2655, FC2610, or FC2600 expansion drive trays, the limit is eight per channel pair. Mixing drive types is supported. When a channel has a mix of FC4600, AT2655, FC2610, or FC2600 drive trays, up to seven drive trays per channel and up to 14 drive trays per controller tray are supported. When a controller tray has a mix of FC4600, AT2655, FC2610, or FC2600 drive trays but each channel has only one type of drive tray, up to seven drive trays for each channel with FC4600 drive trays and up to eight drive trays for each channel with other drive tray types are supported. |
| CE5400-60, CE5400-24, and | 6 Gb/s SAS | 384 | DE1600 DE5600 DE6600 | SAS cables | The CE5400 controller-drive trays have 12-drive, 24-drive, and 60-drive configurations respectively. The DE1600 drive tray has up to 12 drives. |

| Product | Drive Port Speeds | Maximum Number of Drives | Supported Drive Trays | Cable Type | Notes |
|---|-------------------|--------------------------|--------------------------------------|--|---|
| CE5400-12 controller-drive trays | | | | | The DE5600 drive tray has up to 24 drives. The DE6600 has up to 60 drives. The maximum number of drive trays per controller-drive tray is 16. The maximum number of drives for High Performance Computing configurations is 240. |
| CE4900 controller-drive tray | 4 Gb/s | 112 | FC4600 | Copper FC cables or fiber-optic FC cables Copper iSCSI cables | Design for a limit of six expansion drive trays per dual-ported drive channel. |
| CDE3994 controller-drive tray and CDE3992 controller-drive tray | 2 Gb/s or 4 Gb/s | 112 | FC4600 AT2655 FC2610 FC2600 | Copper FC cables or fiber-optic FC cables | Mixing different drive tray types on the same loop is supported. Up to seven attached drive trays if there are no drives in the controller-drive tray and up to six attached drive trays if there are drives in the controller-drive tray are supported. |
| CE2600 controller-drive tray | 6 Gb/s SAS | 192 | DE1600 DE5600 DE6600 | SAS cables | The CE2600 controller-drive tray has both 12-drive and 24-drive configurations. The DE1600 drive tray has up to 12 drives. The DE5600 drive tray has up to 24 drives. The DE6600 has up to 60 drives. |
| CE2600-60 controller-drive tray | | | DE6600 | SAS cables | The DE6600 has up to 60 drives. |

Drive Tray Information by Model

The following tables lists drive tray specifications that might affect your topology. Make sure that your planned topology is compatible with these specifications and restrictions.



NOTE When you mix different types of drive trays, you must consider the total number of drives that are available in the final configuration of the storage array. For example, if you mix FC4600 drive trays with FC2610 drive trays, the total number of drives might be more than the maximum number that each drive channel can support.

For drive trays connected to CE5400

Specifications for Non-SAS Drive Trays

| Model | Port Speed | Drives per Tray | Maximum Number of Drive Trays per Channel |
|-------------------|------------|-----------------|---|
| DE6900 drive tray | 4 Gb/s | 60 | 2 |
| FC4600 drive tray | 4 Gb/s | 16 | 7 |
| FC2610 drive tray | 2 Gb/s | 14 | 8 |
| FC2600 drive tray | 2 Gb/s | 14 | 8 |
| AT2655 drive tray | 2 Gb/s | 14 | 8 |

The CE5400 controller-drive tray models are: CE5400-12, CE5400-24, and the CE5400-60. For the High Performance Computing (HPC) configurations of the CE5400, the total number of drives in the storage array, including the drives in the controller-drive tray and those in all of the attached drive trays, must not exceed 240. For non-HPC configurations of the CE5400, the total number of drives in the storage array, including the drives in the controller-drive tray and those in all of the attached drive trays, must not exceed 384. For all configurations of the CE5400, the total number of trays in the storage array, including the controller-drive tray and all of the attached drive trays, must not exceed 16. The maximum number of drive trays listed in the following table is based on a storage array where the controller-drive tray is fully populated with drives.

Specifications for SAS Drive Trays

| Model | Port Speed | Drives per Tray | Maximum Number of Drives per Channel | Maximum Number of Drive Trays per Channel |
|-------------------|------------|-----------------|--|---|
| DE6600 drive tray | 6 Gb/s | 60 | With CE5400: 360 With CE5400 HPC: 240 With CE2600-60: 180 | With CE5400: 5 With CE5400 HPC: 3 With CE2600-60: 2 |
| DE5600 drive tray | 6 Gb/s | 24 | With CE5400: 384 With CE5400 HPC: 240 With CE2600: 192 | With CE5400: 15 With CE5400 HPC: 9 With CE2600: 7 |
| DE1600 drive tray | 6 Gb/s | 12 | With CE5400: 192 | With CE5400: 15 |

| Model | Port Speed | Drives per Tray | Maximum Number of Drives per Channel | Maximum Number of Drive Trays per Channel |
|-------|------------|-----------------|--|---|
| | | | With CE5400 HPC: 192 With CE2600: 192 | With CE5400 HPC: 15 With CE2600: 15 |

Host Cabling

This chapter provides examples of possible cabling topologies between one or more hosts and a controller tray or a controller-drive tray. Direct-attach topologies, fabric topologies, and mixed topologies are addressed. You are not limited to using only these topologies. Examples are provided to show basic concepts to help you define an optimal host-cabling topology. A table that lists the maximum supported number of hosts is included.

For host port locations on the specific controller tray model or controller-drive tray model that you are installing, see the topics under “Component Locations.”

 **NOTE** If you are using the Remote Volume Mirroring premium feature, see the topics under [Hardware Installation for Remote Volume Mirroring](#) for information on cabling using a host port between two storage arrays.

Host Interface Connections

The CE7900 controller tray connects to hosts through one or two host interface cards (HICs). The CE4900 controller-drive tray has built-in (base) Fibre Channel (FC) connectors for host connections and might also have an optional HIC. The CE2600 controller-drive tray and the CE2600-60 controller-drive tray have built-in (base) SAS connectors for host connections and might also have an optional HIC. The CE5400 controller-drive trays (CE5400-12, CE5400-24, and CE5400-60) have built-in (base) Fibre Channel, and might also have an optional HIC for Fibre Channel connections or InfiniBand connections. All other supported controller trays and controller-drive trays connect through built-in ports.

Types of Host Port Configurations and HICs for Controller Trays and Controller-Drive Trays

| Controller Type | Base Ports | HIC 1 | HIC 2 |
|---|-----------------|---|--|
| CE7900 | None | Quad 4-Gb/s FC, Quad 8-Gb/s FC, Dual 1-Gb/s iSCSI, or Dual 10-Gb/s iSCSI | None, Quad 4-Gb/s FC, Quad 8-Gb/s FC, Dual 1-Gb/s iSCSI, or Dual 10-Gb/s iSCSI |
| CE5400-12, CE5400-24, and CE5400-60 | Quad 8-Gb/s FC | None, Quad 8-Gb/s FC, or Dual 40-Gb/s InfiniBand | None |
| CE4900 | Dual 8-Gb/s FC | None, Dual 8-Gb/s FC, or Dual 1-Gb/s iSCSI | None |
| CE2600 CE2600-60 | Dual 6-Gb/2 SAS | None, Dual 6-Gb/2 SAS, Quad 8-Gb/s FC, | None |

| Controller Type | Base Ports | HIC 1 | HIC 2 |
|-----------------|------------|--|-------|
| | | Quad 1-Gb/s iSCSI, or Dual 10-Gb/s iSCSI | |

The following trays can, with some restrictions, mix host interfaces of different types:

- CE7900 controller trays,
- CE5400 controller-drive trays,
- CE4900 controller-drive trays,
- CE2600 controller-drive trays,
- CE2600-60 controller-drive trays

In all cases, when host interface types are mixed, both controllers in a duplex tray must have the same arrangement of HICs. Each controller must have the same type of HIC in the same relative position as the other controller.

 **NOTE** For a CE5400 controller-drive tray with an InfiniBand HIC, use only InfiniBand host connections. Do not mix Fibre Channel host connections with InfiniBand host connections.

 **NOTE** On the CE2600 controller-drive tray, each controller has a pair of levers with handles for removing the controller from the controller-drive tray. If a controller has a HIC installed, one of these handles on the controller is located next to a host port on the HIC. The close spacing between the handle and the host port might make it difficult to remove a cable that is attached to the host port. If this problem occurs, use a flat-blade screwdriver to compress the release on the cable connector.

A HIC is connected to a host adapter: a host bus adapter (HBA) for Fibre Channel or SAS, or an Ethernet adapter for iSCSI. The host adapter in the host must match the type of HIC to which it is connected.

For best performance, connect an 8-Gb/s Fibre Channel HIC to an 8-Gb/s HBA. If the data rate for the HBA is lower, the data transfer rate will be at the lower rate. For instance, if you connect an 8-Gb/s Fibre Channel HIC to a 4-Gb/s HBA, the data transfer rate is 4 Gb/s.

It is possible for a host to have both iSCSI and Fibre Channel adapters for connections to a storage array that has a mix of HICs. Several restrictions apply to such configurations:

- The root boot feature is not supported for hosts with mixed connections to one storage array.
- Cluster configurations are supported for hosts with mixed connections to one storage array.
- When the host operating system is VMware, mixing connection types within a storage partition is not supported.
- When the host operating system is Windows, mixing connection types within a storage partition is not supported. A single server that attaches to multiple storage partitions on a single storage array must not have any overlap in LUN number assignments given to the volumes.
- For other operating systems, mixed connection types from a host to a single storage array are not supported.

Maximum Number of Host Connections

Maximum Number of Host Connections by Model to a Controller Tray or a Controller-Drive Tray

| Model | Maximum Number of Hosts |
|---|-------------------------|
| CE7922 controller tray and CE7900 controller tray | 2048 |
| CE6998 controller tray and CE6994 controller tray | 1024 |
| CE5400-60, CE5400-24, and CE5400-12 controller-drive trays | 512 |
| CE4900 controller-drive tray | 640 |
| CDE3994 controller-drive tray and | 1024 |
| CDE3992 controller-drive tray | 256 |
| CE2600 controller-drive tray | 256 |
| CE2600-60 controller-drive tray | 256 |

 **ATTENTION Possible loss of data access** – Do not use a combination of HBAs from different vendors in the same storage area network (SAN). For the HBAs to perform correctly, use only HBAs from one manufacturer in a SAN.

Direct-Attach Topologies

The host-to-controller tray topologies presented in this section do not use switches. The host adapters might be HBAs for Fibre Channel or SAS, HCAs for InfiniBand, or Ethernet for iSCSI. Some controller trays and controller-drive trays support more direct host connections than the examples shown. To cable more host connections, follow the pattern established by the examples in this section.

When a host is cabled to a dual-controller controller-drive tray or a dual-controller controller tray, each attached host should have two host adapters installed. For redundancy, connect one host adapter to controller A and the other to controller B.

One Host to a Controller Tray or a Controller-Drive Tray

The following table lists the components in this topology that are non-redundant and present a risk of a single point of failure. The following figure shows an example of a direct-attach topology with one host and a dual-controller controller tray or a dual-controller controller-drive tray.

The example in the figure identifies HBA1 and HBA2 as connecting points on the host. For other configurations, these connecting points might be host channel adapters (HCAs) for InfiniBand connections, Ethernet adapters for iSCSI connections, or a combination of one HBA and one iSCSI Ethernet adapter.

⚠ ATTENTION Possible loss of data access – You must install alternate path software or an alternate path (failover) driver on the host to support failover in the event of an HBA, an HCA, or an iSCSI Ethernet adapter failure or a host channel failure.

Redundant and Non-Redundant Components in a Direct-Attached Configuration with One Host and a Controller Tray or a Controller-Drive Tray

| Component | Redundant | Non-Redundant |
|-------------------------------------|-----------|---------------|
| Host/server | | Non-redundant |
| HBA, HCA, or iSCSI Ethernet adapter | Redundant | |
| Host-to-controller cable | Redundant | |
| Controller | Redundant | |

Direct-Attach Topology – One Host and a Controller Tray or a Controller-Drive Tray

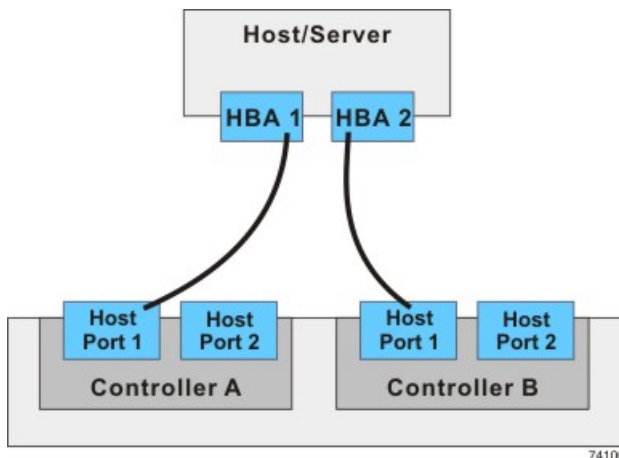

Two Hosts to a Controller Tray or a Controller-Drive Tray

The following table lists the components in this topology which are non-redundant and present a risk of a single point of failure. The following figure shows an example of a direct-attach topology with two hosts and a dual-controller controller tray or a dual-controller controller-drive tray.

The example in the figure shows HBA1 and HBA2 as connecting points on the host. For other configurations, these connecting points might be host channel adapters (HCAs) for InfiniBand connections, Ethernet adapters for iSCSI connections, or a combination of one HBA and one iSCSI Ethernet adapter.

⚠ ATTENTION Possible loss of data access – You must install alternate path software or an alternate path (failover) driver on the host to support failover in the event of an HBA, HCA, or iSCSI Ethernet adapter failure or a host channel failure.

Redundant and Non-Redundant Components in a Direct-Attached Configuration with Two Hosts and a Controller Tray or a Controller-Drive Tray

| Component | Redundant | Non-Redundant |
|--|-----------|---------------|
| Host/server (see note) | Redundant | |
| iSCSI Ethernet adapter, HBA, HCA, or SAS | Redundant | |
| Host-to-controller cable | Redundant | |
| Controller | Redundant | |
| Note – The hosts/servers in this example must be clustered to be redundant. | | |

Direct-Attach Topology – Two Hosts and a Controller Tray or a Controller-Drive Tray

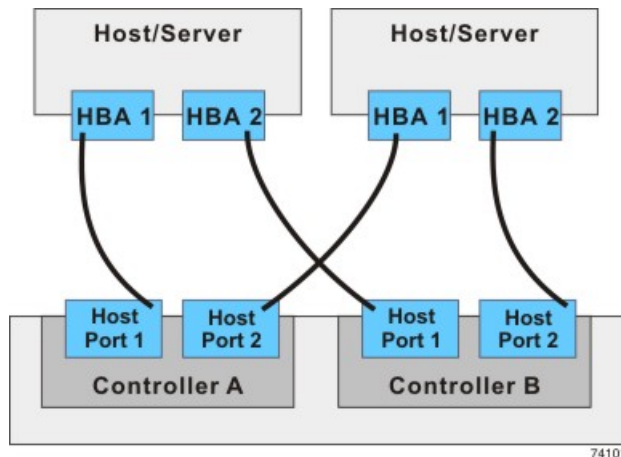

One Hosts with Direct SAS Connections to Four Controller-Drive Trays

The following table lists the components in this topology that are non-redundant and present a risk of a single point of failure. The following figure shows an example of a direct-attach topology with one host and a dual-controller controller-drive tray.

⚠ ATTENTION Possible loss of data access – You must install alternate path software or an alternate path (failover) driver on the host to support failover in the event of a SAS HBA failure or a host channel failure.

Redundant and Non-Redundant Components in a Direct-Attached Configuration with One Host and Four Controller-Drive Trays

| Component | Redundant | Non-Redundant |
|---------------------------|-----------|---------------|
| Host/server (see note) | | Non-Redundant |
| HIC (SAS) | Redundant | |
| Host-to-controller cables | Redundant | |
| Controllers | Redundant | |

Direct-Attach Topology – One Host and Four CE2600 Controller-Drive Trays with SAS Connections

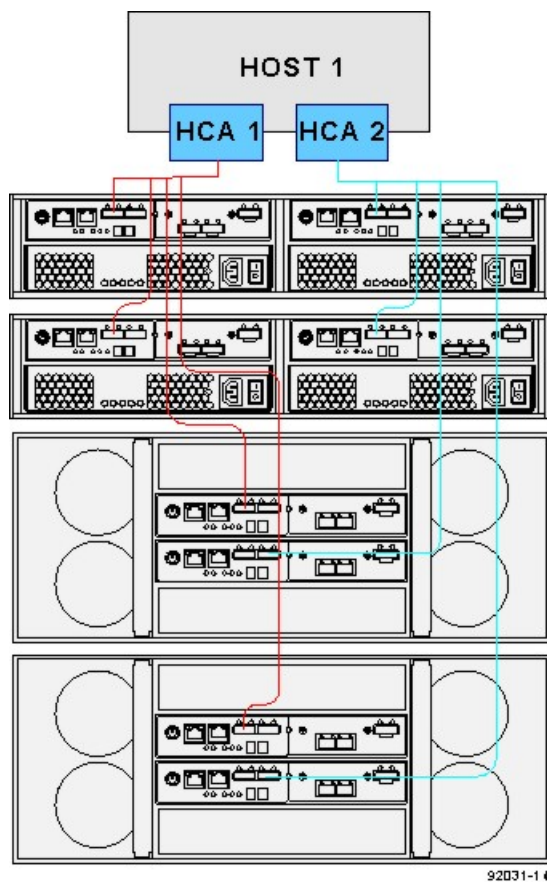

One Single-HBA Host to a Single-Controller Controller Tray or a Single-Controller Controller-Drive Tray

The following figure shows an example of a direct-attach topology with one host and a single-controller controller tray or a single-controller controller-drive tray. The following table describes which of the components in this topology are non-redundant and present a risk of a single point of failure.

Direct-Attach Topology – One Host and a Single-Controller Controller Tray or a Single-Controller Controller-Drive Tray

| Component | Redundant | Non-Redundant |
|--------------------------|-----------|---------------|
| Host/server | | Non-redundant |
| HBA | | Non-redundant |
| Host-to-controller cable | | Non-redundant |
| Controller | | Non-redundant |

Single-HBA Host to a Single-Controller Controller Tray or a Single-Controller Controller-Drive Tray

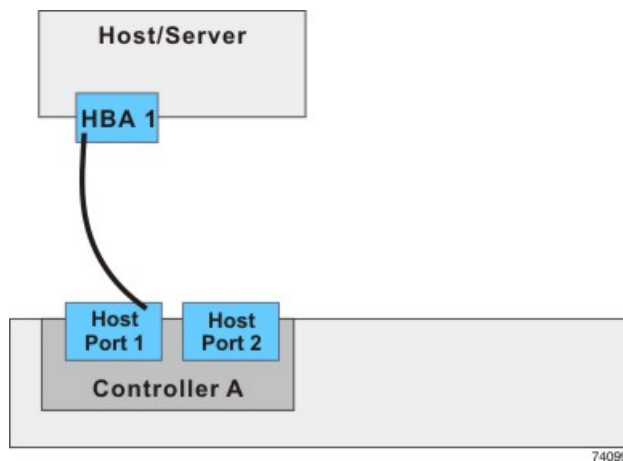

Switch Topologies

The host-to-controller tray topologies or host-to-controller-drive tray topologies presented in this section include one or more switches. The host adapters in the hosts might be HBAs for Fibre Channel, HCAs for InfiniBand, or Ethernet for iSCSI. Switches are not supported for SAS host connections.

When a host is cabled to a dual-controller controller-drive tray or a dual-controller controller tray, each attached host should have two host adapters installed. For redundancy, attach each of the host adapters to a different switch (or switch zone) so that one switch (or zone) connects to controller A and the other to controller B in the controller tray or the controller-drive tray. In the case where a host has one HBA and one iSCSI Ethernet adapter, the two connections might require two different types of switches.

One Host to a Controller Tray or a Controller-Drive Tray

The following figure shows an example of a switch topology with one host, a controller tray or a controller-drive tray, and a zoned switch. The following table describes which of the components in this topology are non-redundant and present a risk of a single point of failure.

⚠ ATTENTION Possible loss of data access – You must install alternate path software or an alternate path (failover) driver on the host to support failover in the event of an HBA failure or a host channel failure.

Redundant and Non-Redundant Components in a Switched Configuration with One Host and a Controller Tray or a Controller-Drive Tray

| Component | Redundant | Non-Redundant |
|--------------------------|-----------|---------------|
| Host/server | | Non-redundant |
| Host adapter | Redundant | |
| Host-to-controller cable | Redundant | |
| Switch | | Non-redundant |
| Controller | Redundant | |

In the following figure, each outlined group of ports represents a zone.

Switch Topology – One Host and a Controller Tray or a Controller-Drive Tray with a Switch

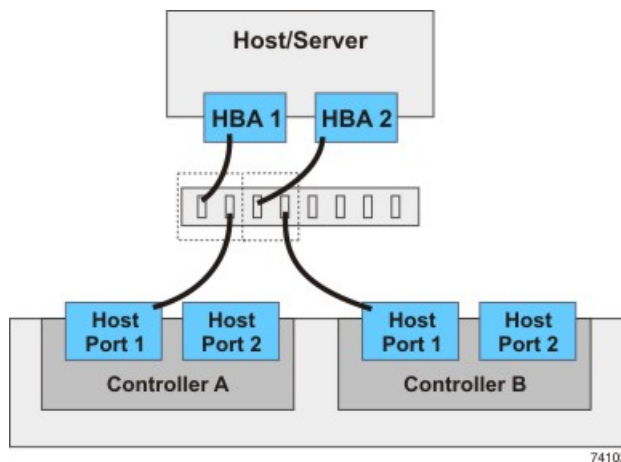

Two Hosts to a Controller Tray or a Controller-Drive Tray

The following figure shows an example of a switch topology with two hosts, a controller tray or a controller-drive tray, and a zoned switch. The following table describes which of the components in this topology are non-redundant and present a risk of a single point of failure.

⚠ ATTENTION Possible loss of data access – You must install alternate path software or an alternate path (failover) driver on the host to support failover in the event of an HBA failure or a host channel failure.

Redundant and Non-Redundant Components in a Switched Configuration with Two Hosts and a Controller Tray or a Controller-Drive Tray

| Component | Redundant | Non-Redundant |
|------------------------|-----------|---------------|
| Host/server (see note) | Redundant | |
| Host adapter | Redundant | |

| Component | Redundant | Non-Redundant |
|--|-----------|---------------|
| Host-to-controller cable | Redundant | |
| Switch | | Non-redundant |
| Controller | Redundant | |
| Note – The hosts/servers in this example must be clustered to be redundant. | | |

In the following figure, each outlined group of ports represents a zone.

Switch Topology – Two Hosts and a Controller Tray or a Controller-Drive Tray with a Zoned Switch

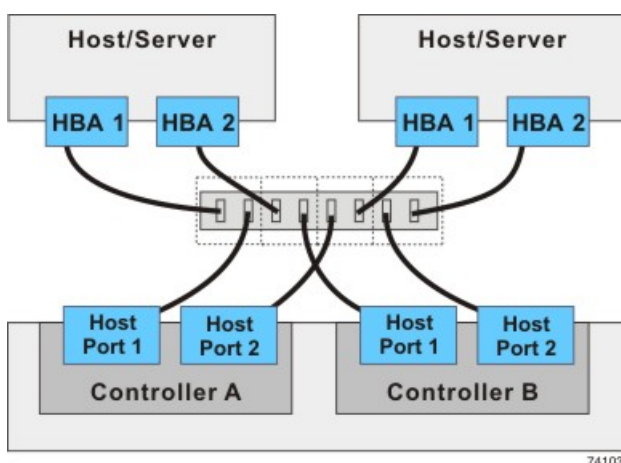

Two Hosts to a Controller-Drive Tray with Switched SAS Connections

The following figure shows an example of a switch topology with two hosts, a controller-drive tray, and two SAS switches. The following table describes which of the components in this topology are non-redundant and present a risk of a single point of failure.

⚠ ATTENTION Possible loss of data access – You must install alternate path software or an alternate path (failover) driver on the host to support failover in the event of an HBA failure or a host channel failure.

Redundant and Non-Redundant Components in a Switched Configuration with two Hosts and a CE2600 Controller-Drive Tray or a CE2600-60 Controller-Drive Tray

| Component | Redundant | Non-Redundant |
|--------------------------|-----------|---------------|
| Hosts/servers (see note) | Redundant | |
| Host adapters | Redundant | |
| Host-to-switch cables | Redundant | |

| Component | Redundant | Non-Redundant |
|--|-----------|---------------|
| Switches | Redundant | |
| Controllers | Redundant | |
| Note – The hosts/servers in this example must be clustered to be redundant. | | |

Direct-Attach Topology – Two Hosts and a CE2600 Controller-Drive Tray with SAS Connections

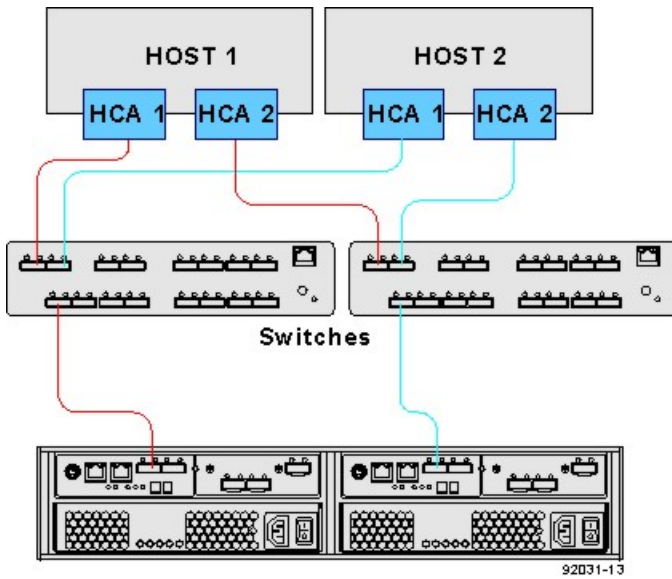

Direct-Attach Topology – Two Hosts and a CE2600-60 Controller-Drive Tray with SAS Connections

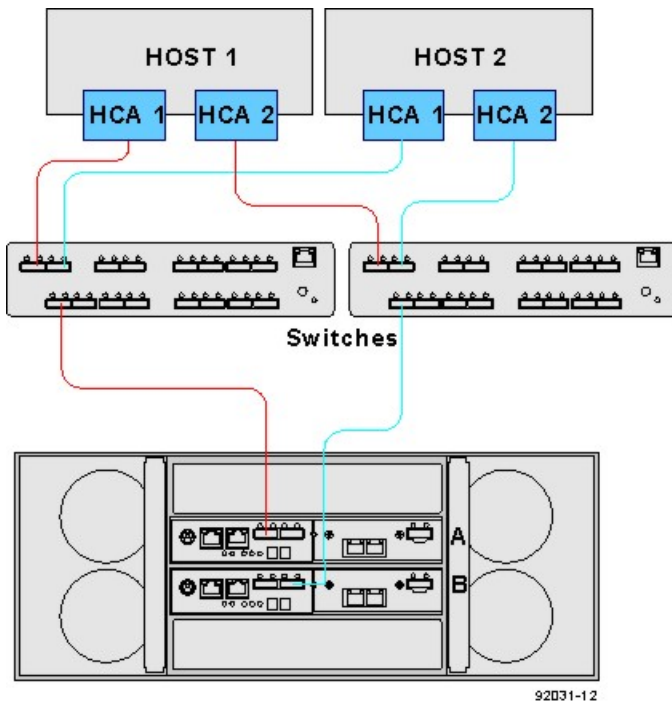

Four Hosts to a Controller Tray or a Controller-Drive Tray

The following figure shows an example of a switch topology with four hosts, a controller tray or a controller-drive tray, and two zoned switches. The following table describes which of the components in this topology are non-redundant and present a risk of a single point of failure.

⚠ ATTENTION Possible loss of data access – You must install alternate path software or an alternate path (failover) driver on the host to support failover in the event of an HBA failure or a host channel failure.

Redundant and Non-Redundant Components in a Switched Configuration with Four Hosts and a Controller Tray or a Controller-Drive Tray

| Component | Redundant | Non-Redundant |
|--|-----------|---------------|
| Host/server (see note) | Redundant | |
| Host adapter | Redundant | |
| Host-to-controller cable | Redundant | |
| Switch | Redundant | |
| Controller | Redundant | |
| Note – The hosts/servers in this example must be clustered to be redundant. | | |

In the following figure, each outlined group of ports represents a zone.

Switch Topology – Four Hosts and a Controller Tray or a Controller-Drive Tray with Two Zoned Switches

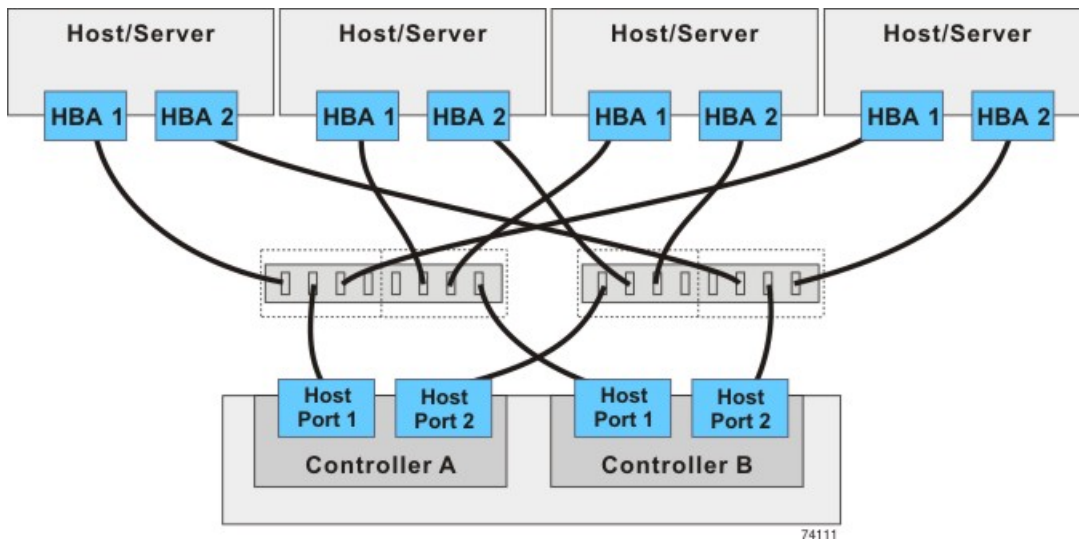

74111

Mixed Topologies

The following table describes which of the components in this topology are non-redundant and present a risk of a single point of failure. The following figure shows an example of a mixed topology; that is, a topology that combines both switch topology and direct-attach topology. This example shows three hosts, a controller tray, and two switches.

The example in the figure identifies HBA1 and HBA2 on each host as connecting points. For other configurations, these connecting points might be Ethernet adapters for iSCSI connections, or a combination of one HBA and one iSCSI Ethernet adapter. Switches are not supported for SAS host connections.

When a host is cabled to a dual-controller controller-drive tray or a dual-controller controller tray, each attached host should have two host adapters installed. The host adapters might be HBAs for Fibre Channel or SAS, or Ethernet for iSCSI. For redundancy, attach each of the host adapters that connects through a switch to a different switch (or switch zone) so that one switch (or zone) connects to controller A and the other to controller B in the controller tray or the controller-drive tray. In the case where a host has one HBA and one iSCSI Ethernet adapter, the two connections might require two different types of switches. Redundancy for a host that attaches directly to a controller tray or a controller-drive tray requires that each host adapter attach to a different controller.

 **ATTENTION Possible loss of data access** – You must install alternate path software or an alternate path (failover) driver on the host to support failover in the event of an HBA failure or a host channel failure.

Redundant and Non-Redundant Components in a Mixed Configuration with Three Hosts and a Controller Tray or a Controller-Drive Tray

| Component | Redundant | Non-Redundant |
|--|-----------|---------------|
| Host/servers 1 and 2 (see note) | Redundant | |
| Host/server 3 | | Non-redundant |
| HBA or Ethernet iSCSI adapter | Redundant | |
| Host-to-controller cable | Redundant | |
| Switch | Redundant | |
| Controller | Redundant | |
| Note – The hosts/servers in this example must be clustered to be redundant. | | |

Mixed Topology – Three Hosts and a Controller Tray

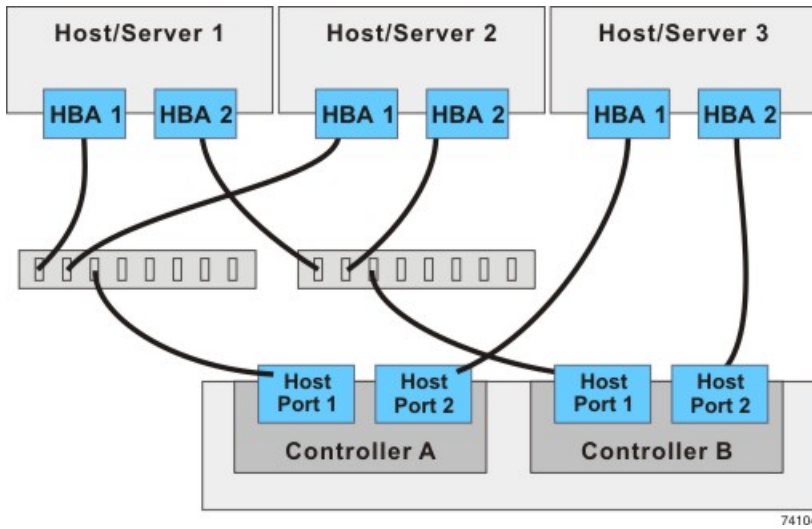

Drive Cabling

This chapter provides examples of cabling between a controller tray or a controller-drive tray and the environmental services monitors (ESMs) of one or more expansion drive trays. This chapter also shows potential combinations of these products in storage array configurations.

NOTE Every example in this chapter provides redundant access to each drive.

See the topics under [Component Locations](#) for drive port locations on the specified controller tray or controller-drive tray and drive tray models that you are installing.

Refer to the section that applies to the controller tray or controller-drive tray to which you are cabling the drive trays.

Drive Channel Redundancy for the CE7900 Controller Tray and the CE7922 Controller Tray

Each controller has four drive channels, and each drive channel has two ports. Therefore, each controller has eight drive ports. A controller tray has eight redundant path pairs that are formed using one drive channel of controller A and one drive channel of controller B. The following figure shows the redundant pairs in a controller tray. The following table lists the numbers of the redundant path pairs and the drive ports of the drive channels from which the redundant path pairs are formed.

NOTE To maintain data access in the event of the failure of a controller, an ESM, or a drive channel, you must connect a drive tray or multiple drive trays on a loop to both drive channels on a redundant path pair.

NOTE If you are connecting DE6900 drive trays and you plan to use the drive-side trunking capability, you must connect each drive tray (or multiple drive trays on a loop) to both drive channels on each of two redundant path pairs to maintain hardware redundancy.

Redundant Path Pairs on the CE7900 Controller Tray and the CE7922 Controller Tray

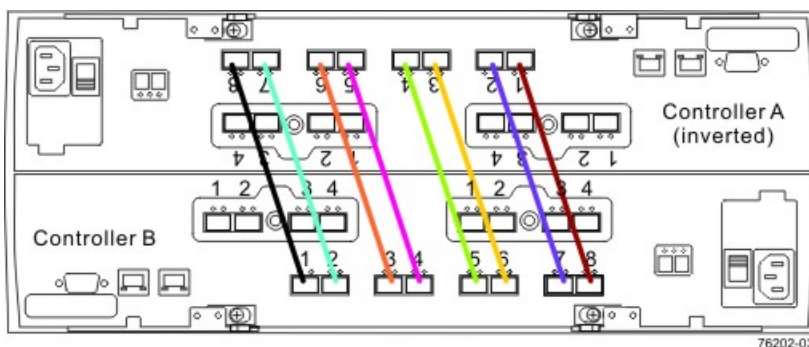

Redundant Path Pairs on the CE7900 Controller Tray and the CE7922 Controller Tray

| Drive Ports on Controller A | Drive Channels on Controller A | Ports on Controller B | Drive Channels on Controller B |
|-----------------------------|--------------------------------|-----------------------|--------------------------------|
| Port 8 | Channel 1 | Port 1 | Channel 5 |
| Port 7 | Channel 1 | Port 2 | Channel 5 |
| Port 6 | Channel 2 | Port 3 | Channel 6 |
| Port 5 | Channel 2 | Port 4 | Channel 6 |
| Port 4 | Channel 3 | Port 5 | Channel 7 |
| Port 3 | Channel 3 | Port 6 | Channel 7 |
| Port 2 | Channel 4 | Port 7 | Channel 8 |
| Port 1 | Channel 4 | Port 8 | Channel 8 |

Drive Channel Redundancy for the CE6998 Controller Tray

Each controller has two drive channels, and each drive channel has two ports. Therefore, each controller has four drive ports. A controller tray has four redundant path pairs that are formed using one drive channel of controller A and one drive channel of controller B. The following figure shows the redundant pairs in a controller tray. The following table lists the numbers of the redundant path pairs and the drive ports of the drive channels from which the redundant path pairs are formed.

NOTE To maintain data access in the event of the failure of a controller, an ESM, or a drive channel, you must connect a drive tray or a string of drive trays to both drive channels on a redundant path pair.

Redundant Path Pairs on the CE6998 Controller Tray

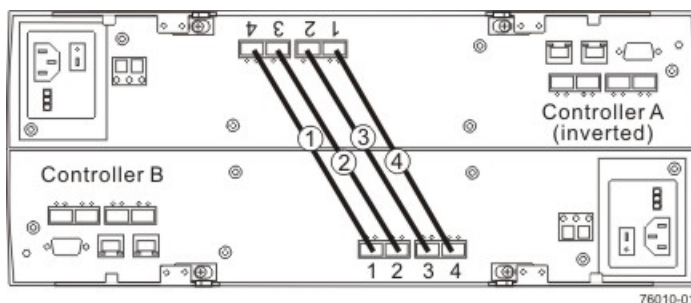

Redundant Path Pairs on the CE6998 Controller Tray

| Redundant Path Pairs | Drive Ports on Controller A | Drive Channels on Controller A | Ports on Controller B | Drive Channels on Controller B |
|----------------------|-----------------------------|--------------------------------|-----------------------|--------------------------------|
| 1 | Port 4 | Channel 1 | Port 1 | Channel 3 |

| Redundant Path Pairs | Drive Ports on Controller A | Drive Channels on Controller A | Ports on Controller B | Drive Channels on Controller B |
|----------------------|-----------------------------|--------------------------------|-----------------------|--------------------------------|
| 2 | Port 3 | Channel 1 | Port 2 | Channel 3 |
| 3 | Port 2 | Channel 2 | Port 3 | Channel 4 |
| 4 | Port 1 | Channel 2 | Port 4 | Channel 4 |

Drive Channel Redundancy for the CE5400-60 Controller-Drive Tray

Each controller in a CE5400-60 has one drive port. When a controller-drive tray has two controllers, the drive port on controller A and the drive port on controller B form a redundant pair. The following figure shows the drive ports on a dual-controller configuration.

NOTE To maintain data access in the event of the failure of a controller, an ESM, or a drive channel, you must connect a drive tray or a string of drive trays to both drive ports on a dual-controller configuration.

Redundant Path Pair on the CE5400-60 Controller-Drive Tray

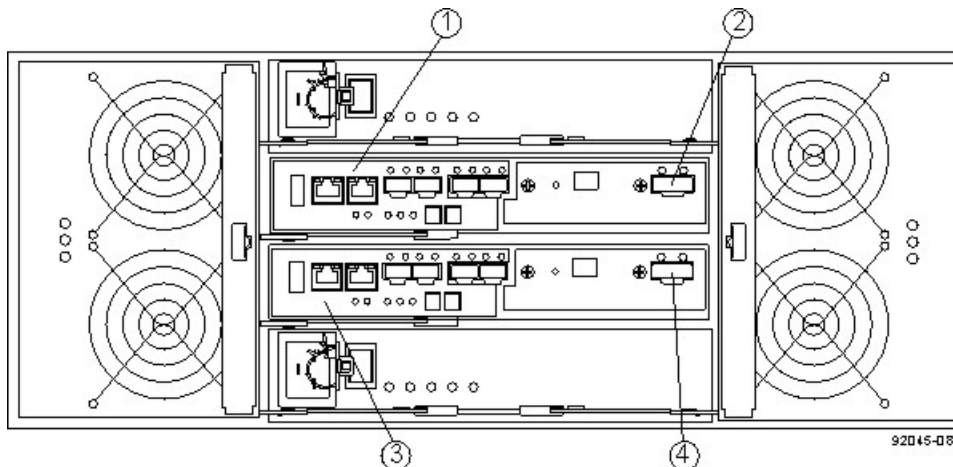

1. Controller Canister A
2. Drive Expansion Connector (Connectors 2 and 4 comprise a redundant path pair.)
3. Controller Canister B
4. Drive Expansion Connector (Connectors 2 and 4 comprise a redundant path pair.)

Drive Channel Redundancy for the CE5400-12 Controller-Drive Tray and the CE5400-24 Controller-Drive Tray

Each controller in a CE5400-12 or a CE5400-24 has one drive port. When a controller-drive tray has two controllers, the drive port on controller A and the drive port on controller B form a redundant pair. The following figure shows the drive ports on a dual-controller configuration.

NOTE To maintain data access in the event of the failure of a controller, an ESM, or a drive channel, you must connect a drive tray or a string of drive trays to both drive ports on a dual-controller configuration.

Redundant Path Pair on the CE5400-24 Controller-Drive Tray or the CE5400-12 Controller-Drive Tray

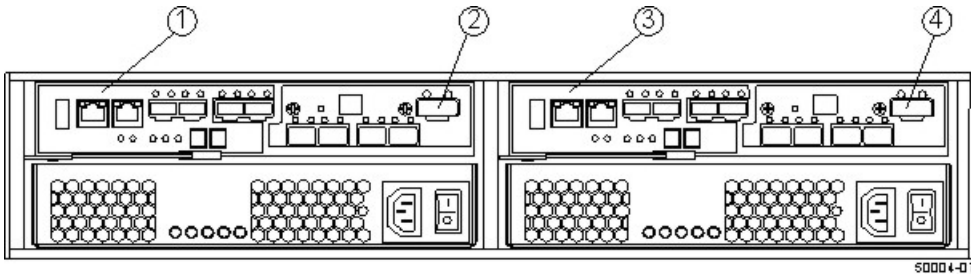

1. Controller Canister A
2. Drive Expansion Connector (Connectors 2 and 4 comprise a redundant path pair.)
3. Controller Canister B
4. Drive Expansion Connector (Connectors 2 and 4 comprise a redundant path pair.)

Drive Channel Redundancy for the CE4900 Controller-Drive Tray

Each controller has one drive channel, and each drive channel has two ports. Therefore, each controller has two drive ports. A controller-drive tray has two redundant path pairs that are formed using one drive channel of controller A and one drive channel of controller B. The following figure shows the redundant pairs in a controller-drive tray. The following table lists the numbers of the redundant path pairs and the drive ports of the drive channels from which the redundant path pairs are formed.

NOTE To maintain data access in the event of the failure of a controller, an ESM, or a drive channel, you must connect a drive tray or a string of drive trays to both drive channels on a redundant path pair.

Redundant Path Pairs on the CE4900 Controller-Drive Tray

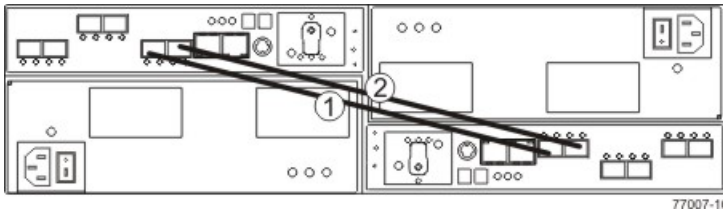

Redundant Path Pairs on the CE4900 Controller-Drive Tray

| Redundant Path Pairs | Drive Ports on Controller A | Drive Channels on Controller A | Ports on Controller B | Drive Channels on Controller B |
|----------------------|-----------------------------|--------------------------------|-----------------------|--------------------------------|
| 1 | Port 2 | Channel 1 | Port 1 | Channel 2 |
| 2 | Port 1 | Channel 1 | Port 2 | Channel 2 |

Drive Channel Redundancy for the CDE3994 Controller-Drive Tray and the CDE3992 Controller-Drive Tray

Each controller has one drive channel, and each drive channel has two ports. Therefore, each controller has two drive ports. A controller-drive tray has two redundant path pairs that are formed using one drive channel of controller A and one drive channel of controller B. The following figure shows the redundant pairs in a controller-drive tray. The following table lists the numbers of the redundant path pairs and the drive ports of the drive channels from which the redundant path pairs are formed.

NOTE To maintain data access in the event of the failure of a controller, an ESM, or a drive channel, you must connect a drive tray or a string of drive trays to both drive channels on a redundant path pair.

Redundant Path Pairs on the CDE3994 Controller-Drive Tray and the CDE3992 Controller-Drive Tray

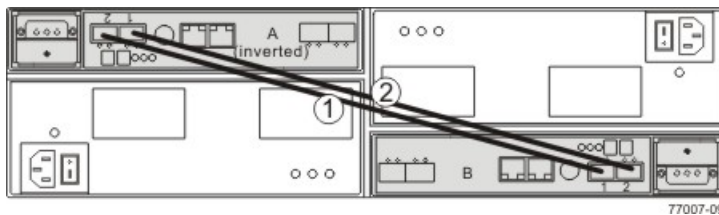

Redundant Path Pairs on the CDE3994 Controller-Drive Tray and the CDE3992 Controller-Drive Tray

| Redundant Path Pairs | Drive Ports on Controller A | Drive Channels on Controller A | Ports on Controller B | Drive Channels on Controller B |
|----------------------|-----------------------------|--------------------------------|-----------------------|--------------------------------|
| 1 | Port 2 | Channel 1 | Port 1 | Channel 2 |
| 2 | Port 1 | Channel 1 | Port 2 | Channel 2 |

Drive Channel Redundancy for the CE2600 Controller-Drive Tray

Each controller in a CE2600 has one drive port. When a controller-drive tray has two controllers, the drive port on controller A and the drive port on controller B form a redundant pair. The following figure shows the drive ports on a dual-controller configuration.

NOTE To maintain data access in the event of the failure of a controller, an ESM, or a drive channel, you must connect a drive tray or a string of drive trays to both drive ports on a dual-controller configuration.

Redundant Path Pair on the CE2600 Controller-Drive Tray

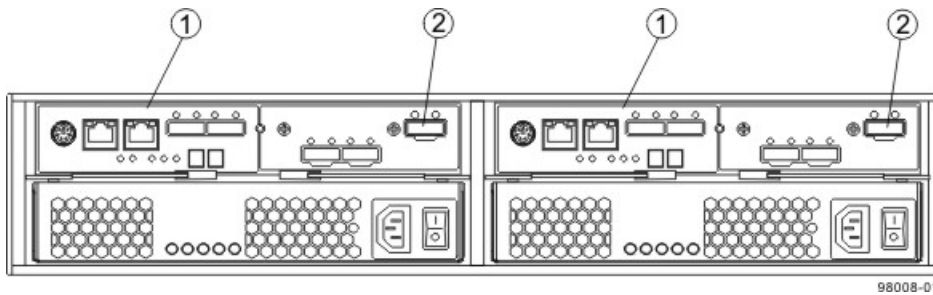

1. Controller Canisters
2. Drive Expansion Connectors (Redundant Path Pair)

Drive Channel Redundancy for the CE2600-60 Controller-Drive Tray

Each controller in a CE2600-60 controller-drive tray has one drive port. When a controller-drive tray has two controllers, the drive port on controller A and the drive port on controller B form a redundant pair. The following figure shows the drive ports on a dual-controller configuration.

IMPORTANT To maintain data access in the event of the failure of a controller, an ESM, or a drive channel, you must connect a drive tray or a string of drive trays to both drive expansion ports on a dual-controller configuration.

Redundant Path Pair on the CE2600-60 Controller-Drive Tray

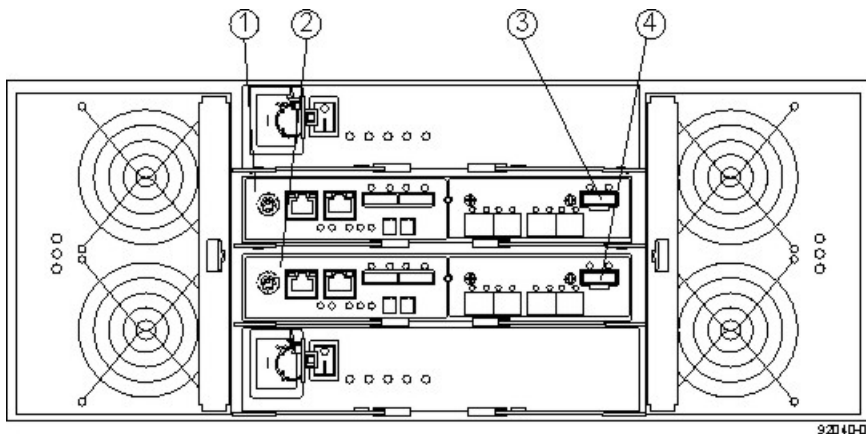

1. Controller A
2. Controller B
3. SAS Drive Expansion Connector (Connectors 3 and 4 comprise a redundant path pair)
4. SAS Drive Expansion Connector (Connectors 3 and 4 comprise a redundant path pair)

ESM Canister Arrangements

Many of the figures in topics for drive cabling topologies show storage arrays that use drive trays with side-by-side ESMs. Each ESM canister has one In port and one Out port (for Fibre Channel) or two SAS In ports and one SAS Expansion port (SAS). The canisters are located adjacent to one another, as shown in the following figures.

Drive Tray with Side-by-Side ESMs (Fibre Channel)

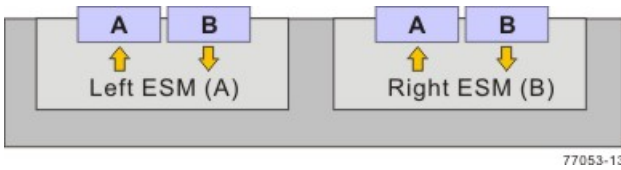

The following figure shows a drive tray with side-by-side ESMs and SAS ports.

Drive Tray with Side-by-Side ESMs (SAS)



The following figure shows another type of drive tray. This type of drive tray has inverted ESM canisters. Other figures in this chapter show this type of drive tray.

Drive Tray with Inverted ESMs

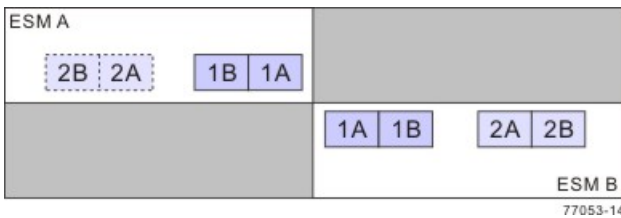

The following figure shows a drive tray with ESM canisters one above the other.

Drive Tray with Stacked ESMs

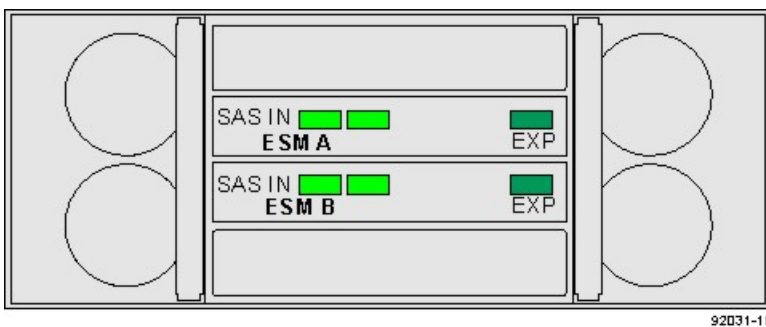

Drive Cabling Topologies for the CE7900 Controller Tray and the CE7922 Controller Tray

You can cable the CE7922 controller tray only to FC4600 drive trays. No more than seven drive trays may be cabled to one loop pair and no more than 28 total drive trays may be cabled to the controller tray.

You can cable the CE7900 controller tray to DE6900 drive trays, FC4600 drive trays, or a combination of the two. No more than seven FC4600 drive trays may be cabled to any one loop pair and no more than two DE6900 drive trays may be cabled to any one loop pair. When a mix of FC4600 drive trays and DE6900 drive trays is cabled to the controller tray, the total number of drives must not exceed 448. The following table shows the allowed combinations of drive trays.

Drive Tray Combinations

| DE6900 Drive Trays per Loop Pair | FC4600 Drive Trays per Loop Pair | | | | | | | |
|----------------------------------|----------------------------------|-----|-----|-----|-----|-----|-----|-----|
| | 0 | 1 | 2 | 3 | 4 | 5 | 6 | 7 |
| 0 | No | Yes | Yes | Yes | Yes | Yes | Yes | Yes |
| 1 | Yes | Yes | Yes | Yes | No | No | No | No |
| 2 | Yes | No | No | No | No | No | No | No |

With a CE7900 controller tray, FC4600 drive trays support solid-state drives (SSDs). A drive tray may have both SSDs and hard disk drives. The maximum number of SSDs for the storage array is 20.

Cabling for the CE7922 Controller Tray or the CE7900 Controller Tray and One to Four FC4600 Drive Trays

The figures and tables in this section show representative configurations for redundant cabling.

One CE7922 Controller Tray or CE7900 Controller Tray and Two Drive Trays

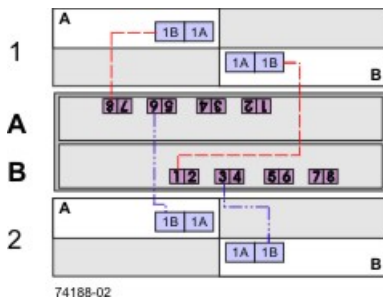

One CE7922 Controller Tray or CE7900 Controller Tray and Four Drive Trays

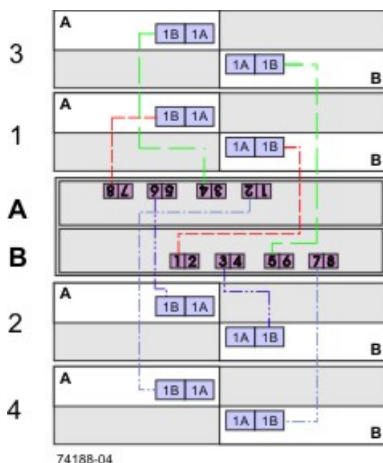

The following table specifies the cabling pattern for a controller tray that is attached to one to four drive trays. The “Cable” column indicates that two cables are used for each drive tray. In the rows for cable 1 and cable 2, for example, the “Xs” indicate that the cables are connected to controller A, channel 1, port 8 and controller B, channel 5, port 1 respectively. The “Bs” in these rows indicate that the other ends of cable 1 and cable 2 are connected to port 1B of the left ESM (ESM A) and port 1B of the right ESM (ESM B) of drive tray 1 respectively. This pattern continues, using even-numbered ports on controller A and odd-numbered ports on controller B for the first four drive trays.

One CE7922 Controller Tray or CE7900 Controller Tray and One to Four Drive Trays

| Cable | Controller A | | | | | | | | Controller B | | | | | | | | | | | | | | |
|-------|----------------|-----|-----|-----|-----|-----|-----|-----|----------------|---|---|---|---|---|---|---|----------------------|---|---|---|---|---|---|
| | Channel Number | | | | | | | | Channel Number | | | | | | | | Drive Trays | | | | | | |
| | Ch1 | Ch2 | Ch3 | Ch4 | Ch5 | Ch6 | Ch7 | Ch8 | 1 | 2 | 3 | 4 | 1 | 2 | 3 | 4 | 1 | 2 | 3 | 4 | | | |
| | Port Number | | | | | | | | Port Number | | | | | | | | ESMs (Left or Right) | | | | | | |
| | 8 | 7 | 6 | 5 | 4 | 3 | 2 | 1 | 1 | 2 | 3 | 4 | 5 | 6 | 7 | 8 | L | R | L | R | L | R | L |
| 1 | X | | | | | | | | | | | | | | | B | | | | | | | |
| 2 | | | | | | | | X | | | | | | | | | B | | | | | | |
| 3 | | | X | | | | | | | | | | | | | | | B | | | | | |
| 4 | | | | | | | | | | X | | | | | | | | | B | | | | |
| 5 | | | | X | | | | | | | | | | | | | | | | B | | | |
| 6 | | | | | | | | | | | X | | | | | | | | | | B | | |
| 7 | | | | | | X | | | | | | | | | | | | | | | | B | |
| 8 | | | | | | | | | | | | | | X | | | | | | | | | B |

Cabling for the CE7922 Controller Tray or the CE7900 Controller Tray and Five to Eight FC4600 Drive Trays

The figures and tables in this section show representative configurations for redundant cabling. Use the information in the previous topic to cable the first four drive trays, and then continue with this topic to cable up to eight additional drive trays.

One CE7922 Controller Tray or CE7900 Controller Tray and Eight Drive Trays

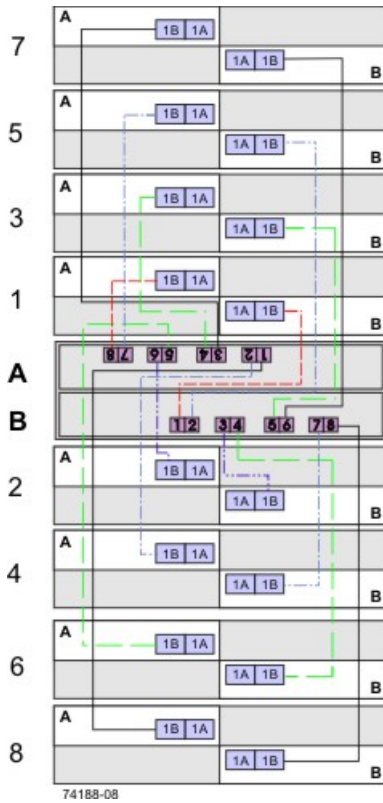

The following table specifies the cabling pattern for a controller tray that is attached to five to eight drive trays. The “Cable” column indicates that two cables are used for each drive tray. In the rows for cable 9 and cable 10, for example, the “Xs” indicate that the cables are connected to controller A, channel 1, port 7 and controller B, channel 5, port 2 respectively. The “Bs” in these rows indicate that the other ends of cable 9 and cable 10 are connected to port 1B of the left ESM1 and port 1B of the right ESM of drive tray 5 respectively. This pattern continues, using odd-numbered ports on controller A and even-numbered ports on controller B for up to eight drive trays.

One CE7922 Controller Tray or CE7900 Controller Tray and Five to Eight Drive Trays

| Cable | Controller A | | | | Controller B | | | | | | | | | | | | | | | | | | | |
|-------|----------------|-----|-----|-----|----------------|-----|-----|-----|----------------------|---|---|---|---|---|---|---|---|---|---|---|---|---|---|---|
| | Channel Number | | | | Channel Number | | | | Drive Trays | | | | | | | | | | | | | | | |
| | Ch1 | Ch2 | Ch3 | Ch4 | Ch5 | Ch6 | Ch7 | Ch8 | 5 | 6 | 7 | 8 | | | | | | | | | | | | |
| | Port Number | | | | Port Number | | | | ESMs (Left or Right) | | | | | | | | | | | | | | | |
| | 8 | 7 | 6 | 5 | 4 | 3 | 2 | 1 | 1 | 2 | 3 | 4 | 5 | 6 | 7 | 8 | L | R | L | R | L | R | L | R |
| 9 | | X | | | | | | | | | | | | | | | | B | | | | | | |
| 10 | | | | | | | | X | | | | | | | | | | | B | | | | | |
| 11 | | | X | | | | | | | | | | | | | | | | | B | | | | |

| Cable | Controller A | | | | | | | | Controller B | | | | | | | | | | | | | | |
|-------|----------------|-----|-----|-----|-----|-----|-----|-----|----------------|---|---|---|---|---|---|---|----------------------|---|---|---|---|---|---|
| | Channel Number | | | | | | | | Channel Number | | | | | | | | Drive Trays | | | | | | |
| | Ch1 | Ch2 | Ch3 | Ch4 | Ch5 | Ch6 | Ch7 | Ch8 | 5 | 6 | 7 | 8 | 5 | 6 | 7 | 8 | 5 | 6 | 7 | 8 | | | |
| | Port Number | | | | | | | | Port Number | | | | | | | | ESMs (Left or Right) | | | | | | |
| | 8 | 7 | 6 | 5 | 4 | 3 | 2 | 1 | 1 | 2 | 3 | 4 | 5 | 6 | 7 | 8 | L | R | L | R | L | R | L |
| 12 | | | | | | | | | | | X | | | | | | | | B | | | | |
| 13 | | | | | | X | | | | | | | | | | | | | | B | | | |
| 14 | | | | | | | | | | | | | X | | | | | | | | B | | |
| 15 | | | | | | | X | | | | | | | | | | | | | | | B | |
| 16 | | | | | | | | | | | | | | | X | | | | | | | | B |

One CE7922 Controller Tray or CE7900 Controller Tray and Nine to 16 FC4600 Drive Trays

When the number of drive trays exceeds eight, the cabling pattern changes significantly. From this point, you will begin to use the “A” ports on the ESMs, and connect the drive trays beyond the eighth one to another drive tray.

If you add drive trays to an existing configuration so that the total number of drive trays attached to one controller tray increases from eight or fewer to a total of more than eight, you must re-cable some of the drive trays that were previously cabled to that controller tray. For each new drive tray beyond the eighth one, in addition to adding two cables to attach the new drive tray, you must move one cable on a previously installed drive tray.

The following figure and table show an example where a ninth and tenth drive tray have been added to a controller tray that previously had eight drive trays. Cable 1 remains the same as in the previous configuration. The end of cable 2 that was previously connected to drive tray 1 now connects to drive tray 9. Cables 17 and 18 are added between drive tray 1 and drive tray 9 so that they now connect in series. Drive tray 10 is added using connections to drive tray 2 that follow the pattern of the connections between drive tray 1 and drive tray 9. Drive tray 3 is not connected to another drive tray, so its cabling remains the same (as it does for drive trays 4 to 8, which do not appear in the table).

You can cable up to 16 drive trays by following the pattern shown in this example.

One CE7922 Controller Tray or CE7900 Controller Tray and 10 Drive Trays

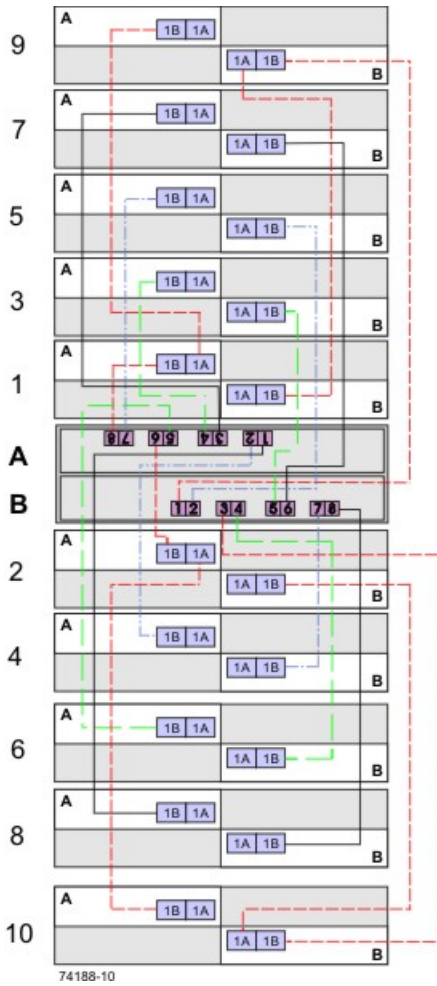

One CE7922 Controller Tray or CE7900 Controller Tray and 10 Drive Trays

| Cable | Controller A | | | | Controller B | | | | | | | | | | | | | | | | | | | |
|-------|----------------|-----|-----|-----|----------------|-----|-----|-----|----------------------|---|---|---|----|---|---|---|---|---|---|---|---|---|---|---|
| | Channel Number | | | | Channel Number | | | | Drive Trays | | | | | | | | | | | | | | | |
| | Ch1 | Ch2 | Ch3 | Ch4 | Ch5 | Ch6 | Ch7 | Ch8 | 1 | 2 | 3 | 9 | 10 | | | | | | | | | | | |
| | Port Number | | | | Port Number | | | | ESMs (Left or Right) | | | | | | | | | | | | | | | |
| | 8 | 7 | 6 | 5 | 4 | 3 | 2 | 1 | 1 | 2 | 3 | 4 | 5 | 6 | 7 | 8 | L | R | L | R | L | R | L | R |
| 1 | X | | | | | | | | | | | | | | | | B | | | | | | | |
| 2 | | | | | | | X | | | | | | | | | | | | | | | | B | |
| 17 | | | | | | | | | | | | | | | | | A | | | | | | B | |
| 18 | | | | | | | | | | | | | | | | | | B | | | | | A | |

| Cable | Controller A | | | | | | | | Controller B | | | | | | | | | | | | | | |
|-------|----------------|-----|-----|-----|-----|-----|-----|-----|----------------|---|---|---|----|---|---|---|----------------------|---|---|---|---|---|---|
| | Channel Number | | | | | | | | Channel Number | | | | | | | | Drive Trays | | | | | | |
| | Ch1 | Ch2 | Ch3 | Ch4 | Ch5 | Ch6 | Ch7 | Ch8 | 1 | 2 | 3 | 9 | 10 | | | | | | | | | | |
| | Port Number | | | | | | | | Port Number | | | | | | | | ESMs (Left or Right) | | | | | | |
| | 8 | 7 | 6 | 5 | 4 | 3 | 2 | 1 | 1 | 2 | 3 | 4 | 5 | 6 | 7 | 8 | L | R | L | R | L | R | L |
| 3 | | | X | | | | | | | | | | | | | | | B | | | | | |
| 4 | | | | | | | | | | X | | | | | | | | | | | | | B |
| 19 | | | | | | | | | | | | | | | | | | A | | | | | B |
| 20 | | | | | | | | | | | | | | | | | | B | | | | | A |
| 5 | | | | X | | | | | | | | | | | | | | | B | | | | |
| 6 | | | | | | | | | | | | X | | | | | | | | B | | | |

One CE7922 Controller Tray or CE7900 Controller Tray and 17 to 28 FC4600 Drive Trays

You can add drive trays in series to each redundant pair of drive ports up to 28 drive trays. In a configuration with 28 drive trays, four of the port pairs will have four drive trays each, while the other four will have three drive trays each. The following figure shows this arrangement schematically. The physical arrangement of the drive trays in cabinets will depend on your particular installation.

The following table shows an example cabling pattern for adding three drive trays (drive trays 9, 17, and 25) in series with drive tray 1. Add drive trays in series to each redundant pair of drive ports so that the number of drive trays for each pair of drive ports remains balanced, to the extent possible. For example, do not add a third drive tray in series with drive tray 1 on ports 8 and 1 if another pair of drive ports has only one drive tray connected.

One CE7922 Controller Tray or CE7900 Controller Tray and Ten Drive Trays

| Cable | Controller A | | | | | | | | Controller B | | | | | | | | | | | | | | |
|-------|----------------|-----|-----|-----|-----|-----|-----|-----|----------------|---|----|----|---|---|---|---|----------------------|---|---|---|---|---|---|
| | Channel Number | | | | | | | | Channel Number | | | | | | | | Drive Trays | | | | | | |
| | Ch1 | Ch2 | Ch3 | Ch4 | Ch5 | Ch6 | Ch7 | Ch8 | 1 | 9 | 17 | 25 | | | | | | | | | | | |
| | Port Number | | | | | | | | Port Number | | | | | | | | ESMs (Left or Right) | | | | | | |
| | 8 | 7 | 6 | 5 | 4 | 3 | 2 | 1 | 1 | 2 | 3 | 4 | 5 | 6 | 7 | 8 | L | R | L | R | L | R | L |
| 1 | X | | | | | | | | | | | | | | | B | | | | | | | |
| 2 | | | | | | | | X | | | | | | | | | | | | | | | B |
| 17 | | | | | | | | | | | | | | | | A | B | | | | | | |

| Cable | Controller A | | | | | | | | Controller B | | | | | | | | | | | | | | | |
|-------|----------------|-----|-----|-----|-----|-----|-----|-----|----------------|---|----|----|---|---|---|---|----------------------|---|---|---|---|---|---|---|
| | Channel Number | | | | | | | | Channel Number | | | | | | | | Drive Trays | | | | | | | |
| | Ch1 | Ch2 | Ch3 | Ch4 | Ch5 | Ch6 | Ch7 | Ch8 | 1 | 9 | 17 | 25 | | | | | | | | | | | | |
| | Port Number | | | | | | | | Port Number | | | | | | | | ESMs (Left or Right) | | | | | | | |
| | 8 | 7 | 6 | 5 | 4 | 3 | 2 | 1 | 1 | 2 | 3 | 4 | 5 | 6 | 7 | 8 | L | R | L | R | L | R | L | R |
| 18 | | | | | | | | | | | | | | | | | | B | A | | | | | |
| 33 | | | | | | | | | | | | | | | | | | | A | B | | | | |
| 34 | | | | | | | | | | | | | | | | | | | B | A | | | | |
| 49 | | | | | | | | | | | | | | | | | | | | A | B | | | |
| 50 | | | | | | | | | | | | | | | | | | | | B | A | | | |

One CE7922 or CE7900 Controller Tray and 28 Drive Trays

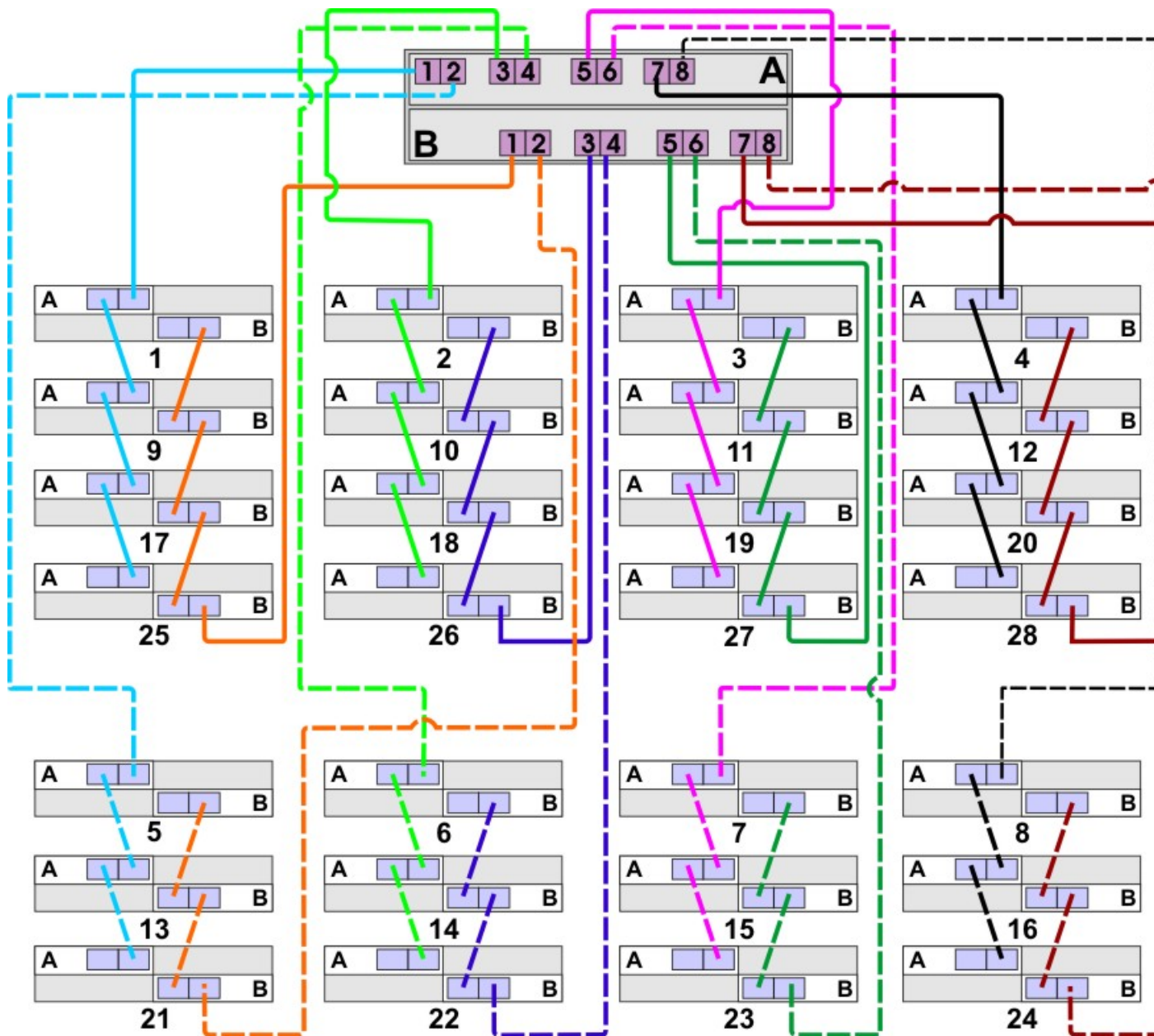

One CE7922 Controller Tray or CE7900 Controller Tray and One to Four DE6900 Drive Trays without Trunking

In the cabling configuration figures that follow, the controller tray is placed on top, and the controllers are labeled as A and B. Because the DE6900 drive trays are very heavy, they are installed starting at the bottom of the cabinet. The drive trays are labeled from the bottom upward as 1, 2, 3, and so on. The figures in this section show representative configurations for cabling.



NOTE The controller tray and the drive trays do not have to be stacked in this exact order, and there is no requirement that you label the drive trays in this particular sequence. Just make sure that the DE6900 drive trays are at the bottom of the cabinet.

One CE7900 Controller Tray or CE7922 Controller Tray and Four DE6900 Drive Trays without Trunking

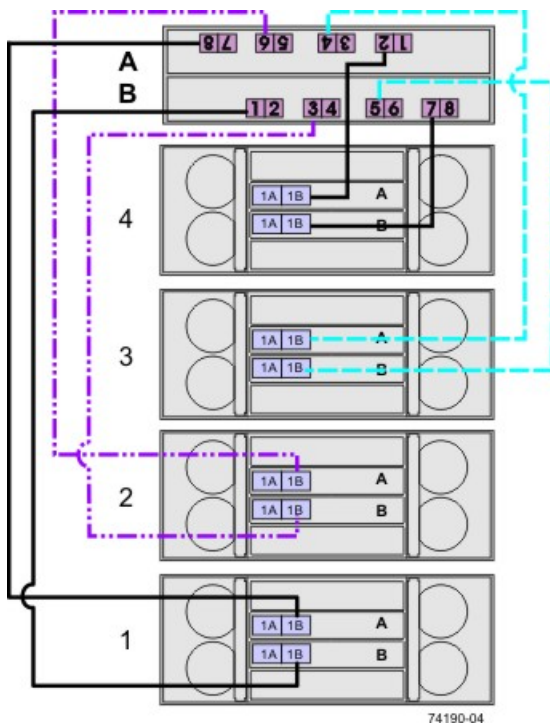

The following table specifies the cabling pattern for a controller tray that is attached to one to four drive trays. The “Cable” column indicates that two cables are used for each drive tray. In the rows for cable 1 and cable 2, for example, the “Xs” indicate that the cables are connected to controller A, channel 1, port 8 and controller B, channel 5, port 1 respectively. The “Bs” in these rows indicate that the other ends of cable 1 and cable 2 are connected to port 1B of the top ESM (ESM A) and port 1B of the bottom ESM (ESM B) of drive tray 1 respectively. This pattern continues, using even-numbered ports on controller A and odd-numbered ports on controller B for the first four drive trays.

One CE7900 Controller Tray or CE7922 Controller Tray and One to Four Drive Trays without Trunking

| Cable | Controller A | | | | Controller B | | | | | | | | | | | | | | | | | | | |
|-------|----------------|-----|-----|-----|----------------|-----|-----|-----|----------------------|---|---|---|---|---|---|---|---|---|---|---|---|---|---|---|
| | Channel Number | | | | Channel Number | | | | Drive Trays | | | | | | | | | | | | | | | |
| | Ch1 | Ch2 | Ch3 | Ch4 | Ch5 | Ch6 | Ch7 | Ch8 | 1 | 2 | 3 | 4 | | | | | | | | | | | | |
| | Port Number | | | | Port Number | | | | ESMs (Left or Right) | | | | | | | | | | | | | | | |
| | 8 | 7 | 6 | 5 | 4 | 3 | 2 | 1 | 1 | 2 | 3 | 4 | 5 | 6 | 7 | 8 | L | R | L | R | L | R | L | R |
| 1 | X | | | | | | | | | | | | | | | | B | | | | | | | |
| 2 | | | | | | | X | | | | | | | | | | | B | | | | | | |
| 3 | | | X | | | | | | | | | | | | | | | | B | | | | | |
| 4 | | | | | | | | | | X | | | | | | | | | | B | | | | |
| 5 | | | | X | | | | | | | | | | | | | | | | | B | | | |

One CE7922 Controller Tray CE7900 Controller Tray and Eight DE6900 Drive Trays without Trunking

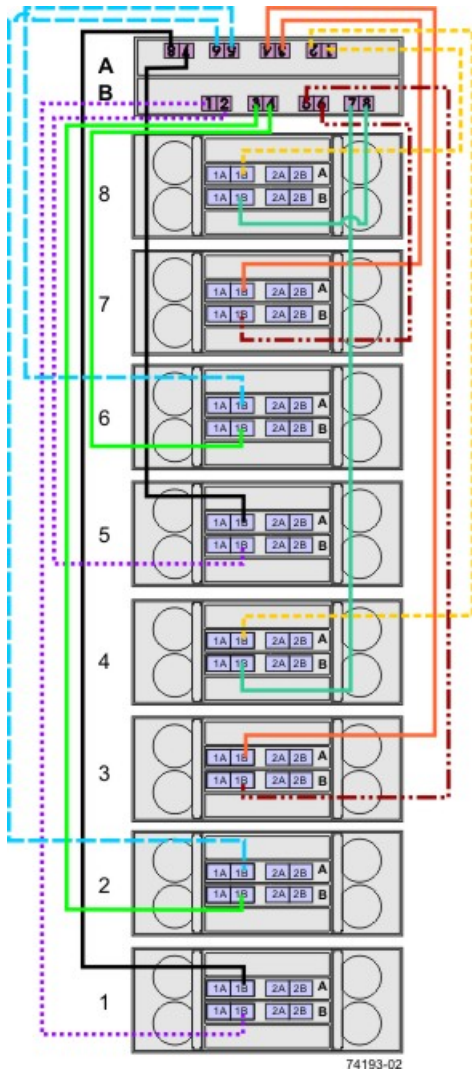

The following table specifies the cabling pattern for a controller tray that is attached to five to eight drive trays. The “Cable” column indicates that two cables are used for each drive tray. In the rows for cable 9 and cable 10, for example, the “Xs” indicate that the cables are connected to controller A, channel 1, port 7 and controller B, channel 5, port 2 respectively. The “Bs” in these rows indicate that the other ends of cable 1 and cable 2 are connected to port 1B of the top ESM (ESM A) and port 1B of the bottom ESM (ESM B) of drive tray 5 respectively. This pattern continues, using odd-numbered ports on controller A and even-numbered ports on controller B for drive trays five through eight.

One CE7922 Controller Tray CE7900 Controller Tray and Five to Eight DE6900 Drive Trays without Trunking

| Cable | Controller A | | | | Controller B | | | | | | | | | | | | | | | | | | | |
|-------|--------------|-----|-----|-----|--------------|-----|-----|-----|---------------------|---|---|---|---|---|---|---|---|---|---|---|---|---|---|---|
| | Channel | | | | Channel | | | | Drive Tray | | | | | | | | | | | | | | | |
| | Ch1 | Ch2 | Ch3 | Ch4 | Ch5 | Ch6 | Ch7 | Ch8 | 5 | 6 | 7 | 8 | | | | | | | | | | | | |
| | Port Number | | | | Port Number | | | | ESM (Top or Bottom) | | | | | | | | | | | | | | | |
| | 8 | 7 | 6 | 5 | 4 | 3 | 2 | 1 | 1 | 2 | 3 | 4 | 5 | 6 | 7 | 8 | T | B | T | B | T | B | T | B |
| 9 | | X | | | | | | | | | | | | | | | B | | | | | | | |
| 10 | | | | | | | | X | | | | | | | | | | B | | | | | | |
| 11 | | | X | | | | | | | | | | | | | | | | B | | | | | |
| 12 | | | | | | | | | X | | | | | | | | | | | B | | | | |
| 13 | | | | | X | | | | | | | | | | | | | | | | B | | | |
| 14 | | | | | | | | | | X | | | | | | | | | | | | B | | |
| 15 | | | | | | | X | | | | | | | | | | | | | | | | B | |
| 16 | | | | | | | | | | | | | | X | | | | | | | | | | B |

One CE7922 Controller Tray or CE7900 Controller Tray and One to Four DE6900 Drive Trays with Trunking

In the figures that follow, the controller tray is shown on top, and the controllers are labeled as A and B. Because the DE6900 drive trays are very heavy, they are installed starting at the bottom of the cabinet. The drive trays are labeled from the bottom upward as 1, 2, 3, and so on.

 **NOTE** The CE7900 controller tray and the DE6900 drive trays do not have to be stacked in this exact order, and there is no requirement that you label the drive trays in this particular sequence. Just make sure the DE6900 drive trays are at the bottom of the cabinet.

Use the configuration examples in this section as a guide to configure your storage array to receive the benefits of drive-side trunking cabling. Drive-side trunking uses the right side of the expansion ports on the rear of the drive trays to allow the full bandwidth potential of the CE7900 controller tray.

Drive-side trunking requires that the ESMs have four ports to support trunked cascading connections to other drive trays. These cascading connections only apply when eight DE6900 drive trays are connected to a single controller tray.

The figures in this section show representative configurations for cabling.

One CE7922 Controller Tray or CE7900 Controller Tray and One DE6900 Drive Tray with Drive-Side Trunking



One CE7922 Controller Tray or CE7900 Controller Tray and Two DE6900 Drive Trays with Drive-Side Trunking

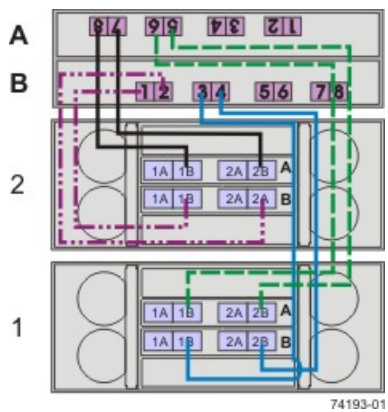

One CE7922 Controller Tray or CE7900 Controller Tray and Four DE6900 Drive Trays with Drive-Side Trunking

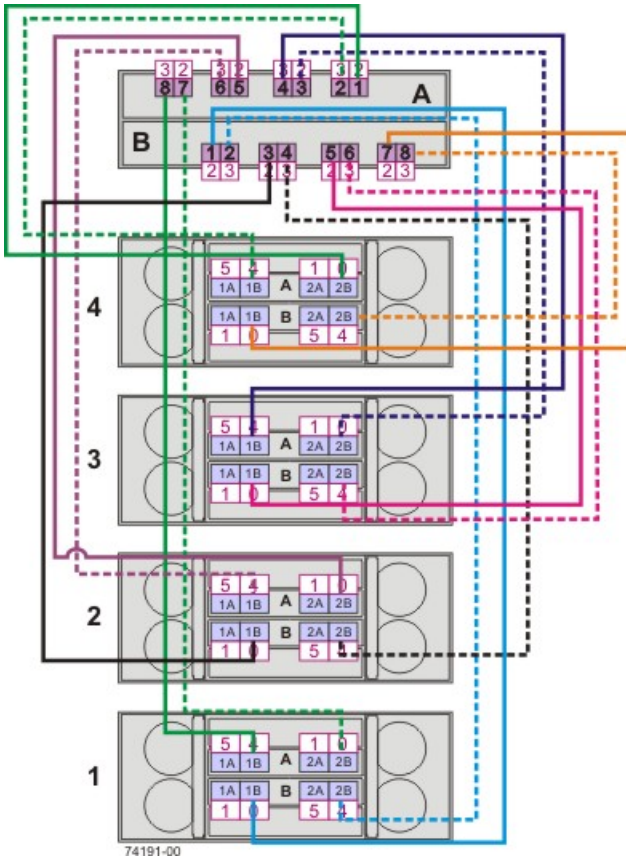

One CE7922 Controller Tray or CE7900 Controller Tray and DE6900 Drive Tray 1 with Drive-Side Trunking

| Cable | Controller A | | | | Controller B | | | | | | | | Drive Tray 1 | | | | | | | | | | | |
|-------|--------------|-----|-----|-----|--------------|-----|-----|-----|---------|---|------------|---|--------------|---|---|---|----|----|----|----|----|----|----|----|
| | Ch1 | Ch2 | Ch3 | Ch4 | Ch5 | Ch6 | Ch7 | Ch8 | Top ESM | | Bottom ESM | | | | | | | | | | | | | |
| | 8 | 7 | 6 | 5 | 4 | 3 | 2 | 1 | 1 | 2 | 3 | 4 | 5 | 6 | 7 | 8 | 1A | 1B | 2A | 2B | 1A | 1B | 2A | 2B |
| 1 | X | | | | | | | | | | | | | | | | | X | | | | | | |
| 2 | | X | | | | | | | | | | | | | | | | | X | | | | | |
| 3 | | | | | | | | | X | | | | | | | | | | | | X | | | |
| 4 | | | | | | | | | | X | | | | | | | | | | | | | | X |

One CE7922 Controller Tray or CE7900 Controller Tray and DE6900 Drive Tray 2 with Drive-Side Trunking

| Cable | Controller A | | | | | | | | Controller B | | | | | | | | Drive Tray 2 | | | | | | | |
|-------|--------------|---|-----|---|-----|---|-----|---|--------------|---|-----|---|-----|---|-----|---|--------------|----|----|----|------------|----|----|----|
| | Ch1 | | Ch2 | | Ch3 | | Ch4 | | Ch5 | | Ch6 | | Ch7 | | Ch8 | | Top ESM | | | | Bottom ESM | | | |
| | 8 | 7 | 6 | 5 | 4 | 3 | 2 | 1 | 1 | 2 | 3 | 4 | 5 | 6 | 7 | 8 | 1A | 1B | 2A | 2B | 1A | 1B | 2A | 2B |
| 1 | | | X | | | | | | | | | | | | | | | X | | | | | | |
| 2 | | | | X | | | | | | | | | | | | | | | | X | | | | |
| 3 | | | | | | | | | | | X | | | | | | | | | | X | | | |
| 4 | | | | | | | | | | | | X | | | | | | | | | | | | X |

One CE7922 Controller Tray or CE7900 Controller Tray and DE6900 Drive Tray 3 with Drive-Side Trunking

| Cable | Controller A | | | | | | | | Controller B | | | | | | | | Drive Tray 3 | | | | | | | |
|-------|--------------|---|-----|---|-----|---|-----|---|--------------|---|-----|---|-----|---|-----|---|--------------|----|----|----|------------|----|----|----|
| | Ch1 | | Ch2 | | Ch3 | | Ch4 | | Ch5 | | Ch6 | | Ch7 | | Ch8 | | Top ESM | | | | Bottom ESM | | | |
| | 8 | 7 | 6 | 5 | 4 | 3 | 2 | 1 | 1 | 2 | 3 | 4 | 5 | 6 | 7 | 8 | 1A | 1B | 2A | 2B | 1A | 1B | 2A | 2B |
| 1 | | | | | X | | | | | | | | | | | | | X | | | | | | |
| 2 | | | | | | X | | | | | | | | | | | | | | X | | | | |
| 3 | | | | | | | | | | | | | | X | | | | | | | X | | | |
| 4 | | | | | | | | | | | | | | | X | | | | | | | | | X |

One CE7922 Controller Tray or CE7900 Controller Tray and DE6900 Drive Tray 4 with Drive-Side Trunking

| Cable | Controller A | | | | | | | | Controller B | | | | | | | | Drive Tray 4 | | | | | | | |
|-------|--------------|---|-----|---|-----|---|-----|---|--------------|---|-----|---|-----|---|-----|---|--------------|----|----|----|------------|----|----|----|
| | Ch1 | | Ch2 | | Ch3 | | Ch4 | | Ch5 | | Ch6 | | Ch7 | | Ch8 | | Top ESM | | | | Bottom ESM | | | |
| | 8 | 7 | 6 | 5 | 4 | 3 | 2 | 1 | 1 | 2 | 3 | 4 | 5 | 6 | 7 | 8 | 1A | 1B | 2A | 2B | 1A | 1B | 2A | 2B |
| 1 | | | | | | | X | | | | | | | | | | | X | | | | | | |
| 2 | | | | | | | | X | | | | | | | | | | | | X | | | | |
| 3 | | | | | | | | | | | | | | | X | | | | | | X | | | |
| 4 | | | | | | | | | | | | | | | | X | | | | | | | | X |

One CE7922 Controller Tray or CE7900 Controller Tray and Five to Eight DE6900 Drive Trays with Drive-Side Trunking

In the cabling configuration figure that follows, the controller tray is placed on top, and the controllers are labeled as A and B. Because the DE6900 drive trays are very heavy, they are installed starting at the bottom of the cabinet. The drive trays are labeled from the bottom upward as 1, 2, 3, and so on.



NOTE The controller tray and the drive trays do not have to be stacked in this exact order, and there is no requirement that you label the drive trays in this particular sequence. Just make sure the DE6900 drive trays are at the bottom of the cabinet.

Use the configuration examples in this section as a guide to configure your storage array to receive the benefits of drive-side trunking cabling. Drive-side trunking uses the right side of the expansion ports on the rear of the drive trays to allow the full bandwidth potential of the controller tray.

Drive-side trunking requires that the ESMs have four ports to support trunked cascading connections to other drive trays. These cascading connections only apply when eight DE6900 drive trays are connected to a single controller tray.

The figure in this section shows a representative configuration for cabling. Use the tables in this section to see specific cabling patterns for other configurations.

One CE7922 Controller Tray or CE7900 Controller Tray and Eight DE6900 Drive Trays with Drive-Side Trunking

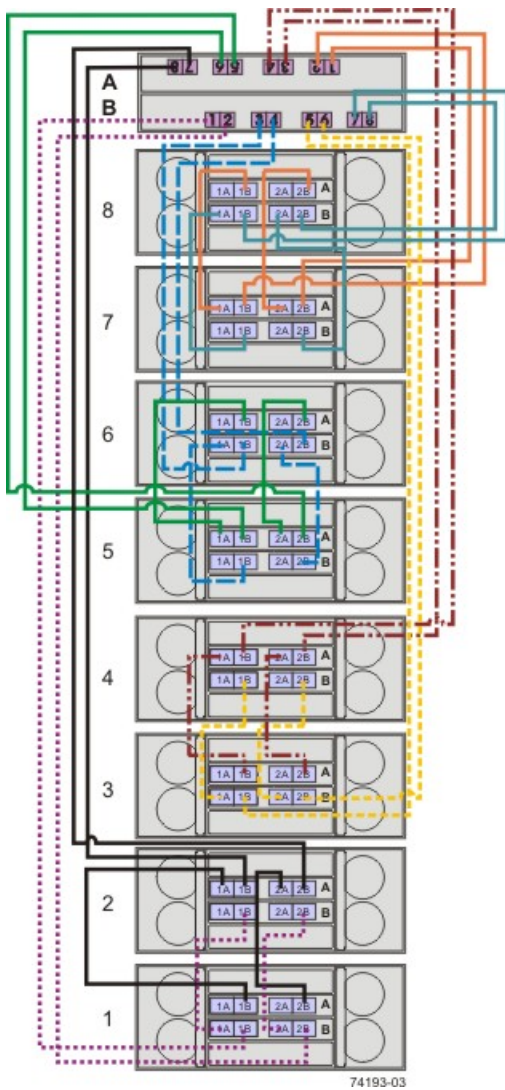

One CE7922 Controller Tray or CE7900 Controller Tray and DE6900 Drive Trays 1 and 2 with Drive-Side Trunking

| Cable | Controller A | | | | | | | | Controller B | | | | | | | | Drive Tray 1 | | | | | | | |
|-------|--------------|---|-----|---|-----|---|-----|---|--------------|---|-----|---|-----|---|-----|---|--------------|----|----|----|------------|----|----|----|
| | Ch1 | | Ch2 | | Ch3 | | Ch4 | | Ch5 | | Ch6 | | Ch7 | | Ch8 | | Top ESM | | | | Bottom ESM | | | |
| | 8 | 7 | 6 | 5 | 4 | 3 | 2 | 1 | 1 | 2 | 3 | 4 | 5 | 6 | 7 | 8 | 1A | 1B | 2A | 2B | 1A | 1B | 2A | 2B |
| 1 | | | | | | | | X | | | | | | | | | | | | | X | | | |
| 2 | | | | | | | | | X | | | | | | | | | | | | | | X | |

| Cable | Drive Tray 1 | | | | | | | | Drive Tray 2 | | | | | | | |
|-------|--------------|----|----|----|------------|----|----|----|--------------|----|----|----|------------|----|----|----|
| | Top ESM | | | | Bottom ESM | | | | Top ESM | | | | Bottom ESM | | | |
| | 1A | 1B | 2A | 2B | 1A | 1B | 2A | 2B | 1A | 1B | 2A | 2B | 1A | 1B | 2A | 2B |
| 3 | | X | | | | | | | X | | | | | | | |
| 4 | | | | X | | | | | | | X | | | | | |
| 5 | | | | | X | | | | | | | | X | | | |
| 6 | | | | | | | X | | | | | | | | | X |

| Cable | Controller A | | | | | | | | Controller B | | | | | | | | Drive Tray 2 | | | | | | | |
|-------|--------------|---|-----|---|-----|---|-----|---|--------------|---|-----|---|-----|---|-----|---|--------------|----|----|----|------------|----|----|----|
| | Ch1 | | Ch2 | | Ch3 | | Ch4 | | Ch5 | | Ch6 | | Ch7 | | Ch8 | | Top ESM | | | | Bottom ESM | | | |
| | 8 | 7 | 6 | 5 | 4 | 3 | 2 | 1 | 1 | 2 | 3 | 4 | 5 | 6 | 7 | 8 | 1A | 1B | 2A | 2B | 1A | 1B | 2A | 2B |
| 7 | X | | | | | | | | | | | | | | | | X | | | | | | | |
| 8 | | X | | | | | | | | | | | | | | | | | X | | | | | |

One CE7922 Controller Tray or CE7900 Controller Tray and DE6900 Drive Trays 3 and 4 with Drive-Side Trunking

| Cable | Controller A | | | | | | | | Controller B | | | | | | | | Drive Tray 3 | | | | | | | |
|-------|--------------|---|-----|---|-----|---|-----|---|--------------|---|-----|---|-----|---|-----|---|--------------|----|----|----|------------|----|----|----|
| | Ch1 | | Ch2 | | Ch3 | | Ch4 | | Ch5 | | Ch6 | | Ch7 | | Ch8 | | Top ESM | | | | Bottom ESM | | | |
| | 8 | 7 | 6 | 5 | 4 | 3 | 2 | 1 | 1 | 2 | 3 | 4 | 5 | 6 | 7 | 8 | 1A | 1B | 2A | 2B | 1A | 1B | 2A | 2B |
| 1 | | | | | | | | | | | | X | | | | | | | | | X | | | |
| 2 | | | | | | | | | | | | | X | | | | | | | | | | X | |

| Cable | Drive Tray 3 | | | | | | | | Drive Tray 4 | | | | | | | |
|-------|--------------|----|----|----|------------|----|----|----|--------------|----|----|----|------------|----|----|----|
| | Top ESM | | | | Bottom ESM | | | | Top ESM | | | | Bottom ESM | | | |
| | 1A | 1B | 2A | 2B | 1A | 1B | 2A | 2B | 1A | 1B | 2A | 2B | 1A | 1B | 2A | 2B |
| 3 | | | | | X | | | | | | | | | X | | |
| 4 | | | | | | | X | | | | | | | | | X |
| 5 | | X | | | | | | | X | | | | | | | |
| 6 | | | | X | | | | | | | X | | | | | |

| Cable | Controller A | | | | | | | | Controller B | | | | | | | | Drive Tray 4 | | | | | | | |
|-------|--------------|---|-----|---|-----|---|-----|---|--------------|---|-----|---|-----|---|-----|---|--------------|----|----|----|------------|----|----|----|
| | Ch1 | | Ch2 | | Ch3 | | Ch4 | | Ch5 | | Ch6 | | Ch7 | | Ch8 | | Top ESM | | | | Bottom ESM | | | |
| | 8 | 7 | 6 | 5 | 4 | 3 | 2 | 1 | 1 | 2 | 3 | 4 | 5 | 6 | 7 | 8 | 1A | 1B | 2A | 2B | 1A | 1B | 2A | 2B |
| 7 | | | | | X | | | | | | | | | | | | X | | | | | | | |
| 8 | | | | | | X | | | | | | | | | | | | | X | | | | | |

One CE7922 Controller Tray or CE7900 Controller Tray and DE6900 Drive Trays 5 and 6 with Drive-Side Trunking

| Cable | Controller A | | | | | | | | Controller B | | | | | | | | Drive Tray 5 | | | | | | | |
|-------|--------------|---|-----|---|-----|---|-----|---|--------------|---|-----|---|-----|---|-----|---|--------------|----|----|----|------------|----|----|----|
| | Ch1 | | Ch2 | | Ch3 | | Ch4 | | Ch5 | | Ch6 | | Ch7 | | Ch8 | | Top ESM | | | | Bottom ESM | | | |
| | 8 | 7 | 6 | 5 | 4 | 3 | 2 | 1 | 1 | 2 | 3 | 4 | 5 | 6 | 7 | 8 | 1A | 1B | 2A | 2B | 1A | 1B | 2A | 2B |
| 1 | | | X | | | | | | | | | | | | | | X | | | | | | | |
| 2 | | | | X | | | | | | | | | | | | | | | X | | | | | |

| Cable | Drive Tray 5 | | | | | | | | Drive Tray 6 | | | | | | | |
|-------|--------------|----|----|----|------------|----|----|----|--------------|----|----|----|------------|----|----|----|
| | Top ESM | | | | Bottom ESM | | | | Top ESM | | | | Bottom ESM | | | |
| | 1A | 1B | 2A | 2B | 1A | 1B | 2A | 2B | 1A | 1B | 2A | 2B | 1A | 1B | 2A | 2B |
| 3 | X | | | | | | | | | X | | | | | | |
| 4 | | | X | | | | | | | | | X | | | | |
| 5 | | | | | | X | | | | | | | X | | | |
| 6 | | | | | | | | X | | | | | | | X | |

| Cable | Controller A | | | | | | | | Controller B | | | | | | | | Drive Tray 6 | | | | | | | |
|-------|--------------|---|-----|---|-----|---|-----|---|--------------|---|-----|---|-----|---|-----|---|--------------|----|----|----|------------|----|----|----|
| | Ch1 | | Ch2 | | Ch3 | | Ch4 | | Ch5 | | Ch6 | | Ch7 | | Ch8 | | Top ESM | | | | Bottom ESM | | | |
| | 8 | 7 | 6 | 5 | 4 | 3 | 2 | 1 | 1 | 2 | 3 | 4 | 5 | 6 | 7 | 8 | 1A | 1B | 2A | 2B | 1A | 1B | 2A | 2B |
| 7 | | | | | | | | | | | X | | | | | | | | | | X | | | |
| 8 | | | | | | | | | | | | X | | | | | | | | | | | X | |

One CE7922 Controller Tray or CE7900 Controller Tray and DE6900 Drive Trays 7 and 8 with Drive-Side Trunking

| Cable | Controller A | | | | | | | | Controller B | | | | | | | | Drive Tray 7 | | | | | | | |
|-------|--------------|---|-----|---|-----|---|-----|---|--------------|---|-----|---|-----|---|-----|---|--------------|----|----|----|------------|----|----|----|
| | Ch1 | | Ch2 | | Ch3 | | Ch4 | | Ch5 | | Ch6 | | Ch7 | | Ch8 | | Top ESM | | | | Bottom ESM | | | |
| | 8 | 7 | 6 | 5 | 4 | 3 | 2 | 1 | 1 | 2 | 3 | 4 | 5 | 6 | 7 | 8 | 1A | 1B | 2A | 2B | 1A | 1B | 2A | 2B |
| 1 | | | | | | | X | | | | | | | | | | X | | | | | | | |
| 2 | | | | | | | | X | | | | | | | | | | | X | | | | | |

| Cable | Drive Tray 7 | | | | | | | | Drive Tray 8 | | | | | | | |
|-------|--------------|----|----|----|------------|----|----|----|--------------|----|----|----|------------|----|----|----|
| | Top ESM | | | | Bottom ESM | | | | Top ESM | | | | Bottom ESM | | | |
| | 1A | 1B | 2A | 2B | 1A | 1B | 2A | 2B | 1A | 1B | 2A | 2B | 1A | 1B | 2A | 2B |
| 3 | X | | | | | | | | | X | | | | | | |
| 4 | | | X | | | | | | | | | X | | | | |
| 5 | | | | | | X | | | | | | | X | | | |
| 6 | | | | | | | | X | | | | | | | X | |

| Cable | Controller A | | | | | | | | Controller B | | | | | | | | Drive Tray 8 | | | | | | | |
|-------|--------------|---|-----|---|-----|---|-----|---|--------------|---|-----|---|-----|---|-----|---|--------------|----|----|----|------------|----|----|----|
| | Ch1 | | Ch2 | | Ch3 | | Ch4 | | Ch5 | | Ch6 | | Ch7 | | Ch8 | | Top ESM | | | | Bottom ESM | | | |
| | 8 | 7 | 6 | 5 | 4 | 3 | 2 | 1 | 1 | 2 | 3 | 4 | 5 | 6 | 7 | 8 | 1A | 1B | 2A | 2B | 1A | 1B | 2A | 2B |
| 7 | | | | | | | | | | | | | | X | | | | | | | X | | | |
| 8 | | | | | | | | | | | | | | | X | | | | | | | | X | |

One CE7900 Controller Tray and Multiple Types of Drive Trays

If you are cabling a mix of DE6900 drive trays and FC4600 drive trays, the following restrictions apply:

- Connect no more than two DE6900 drive trays per loop pair and no more than eight DE6900 drive trays per controller tray.
- Connect no more than seven FC4600 drive trays per loop pair and no more than 28 FC4600 drive trays per controller tray. In configurations that contain one DE6900 drive tray, connect no more than 21 FC4600 drive trays per controller tray.
- When FC4600 and DE6900 drive trays are mixed on the same loop, only one DE6900 drive tray and up to three FC4600 drive trays can share a loop.
- When FC4600 and DE6900 drive trays are mixed, the total number of drives must not exceed 448.

Drive Cabling Topologies for the CE6998 Controller Tray

One CE6998 Controller Tray and One Drive Tray

If you are cabling one CE6998 controller tray to one drive tray, use the cabling topology shown in the following table and figure.

One CE6998 Controller Tray and One Drive Tray

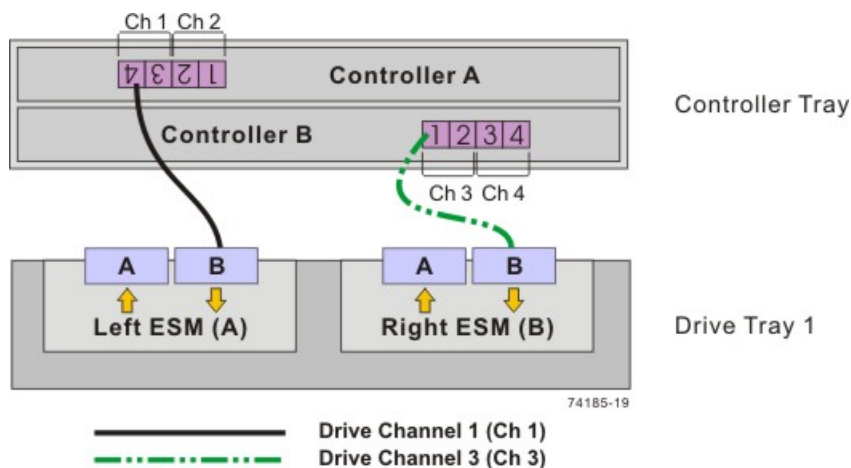

One CE6998 Controller Tray and One Drive Tray

| Drive Channel | Connection Point | | Connection Point | |
|---------------|-------------------|--------------------------|-------------------|--------------------------|
| | Tray or Component | Port Number and Location | Tray or Component | Port Number and Location |
| 1 | Controller A | 4 | Drive tray 1 | Left ESM, port B |
| 3 | Controller B | 1 | Drive tray 1 | Right ESM, port B |



NOTE If you have drive trays with inverted ESM canisters, see [ESM Canister Arrangements](#).

One CE6998 Controller Tray and Two Drive Trays

If you are cabling one CE6998 controller tray to two drive trays, use the cabling topology described in the following table and figure.

One CE6998 Controller Tray and Two Drive Trays

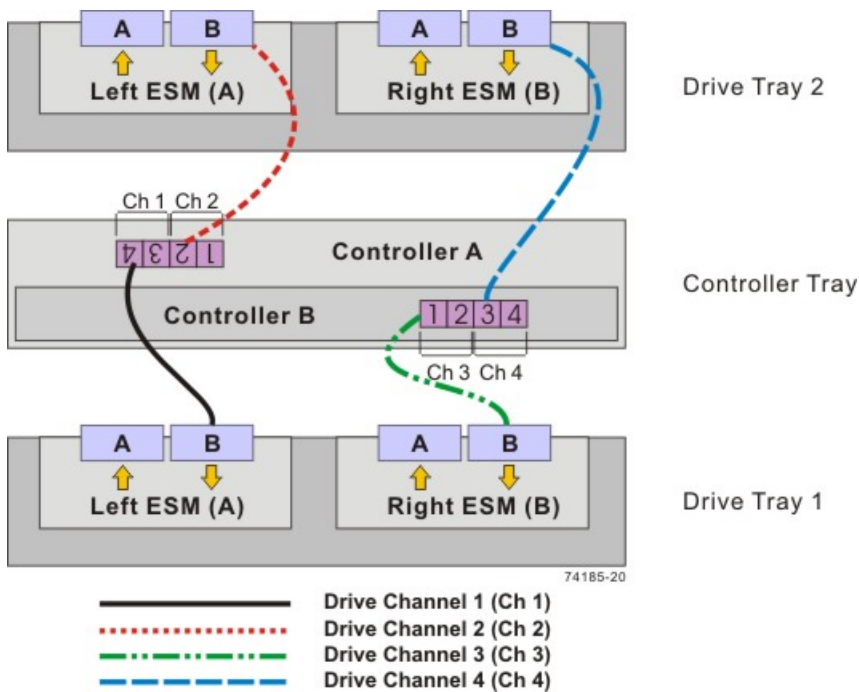

One CE6998 Controller Tray and Two Drive Trays

| Drive Channel | Connection Point | | Connection Point | |
|---------------|-------------------|--------------------------|-------------------|--------------------------|
| | Tray or Component | Port Number and Location | Tray or Component | Port Number and Location |
| 1 | Controller A | 4 | Drive tray 1 | Left ESM, port B |
| 2 | Controller A | 2 | Drive tray 2 | Left ESM, port B |
| 3 | Controller B | 1 | Drive tray 1 | Right ESM, port B |
| 4 | Controller B | 3 | Drive tray 2 | Right ESM, port B |

 **NOTE** If you have drive trays with inverted ESM canisters, see [ESM Canister Arrangements](#).

One CE6998 Controller Tray and Four Drive Trays

If you are cabling one CE6998 controller tray to four drive trays, use the cabling topology shown in the following figure and table.

One CE6998 Controller Tray and Four Drive Trays

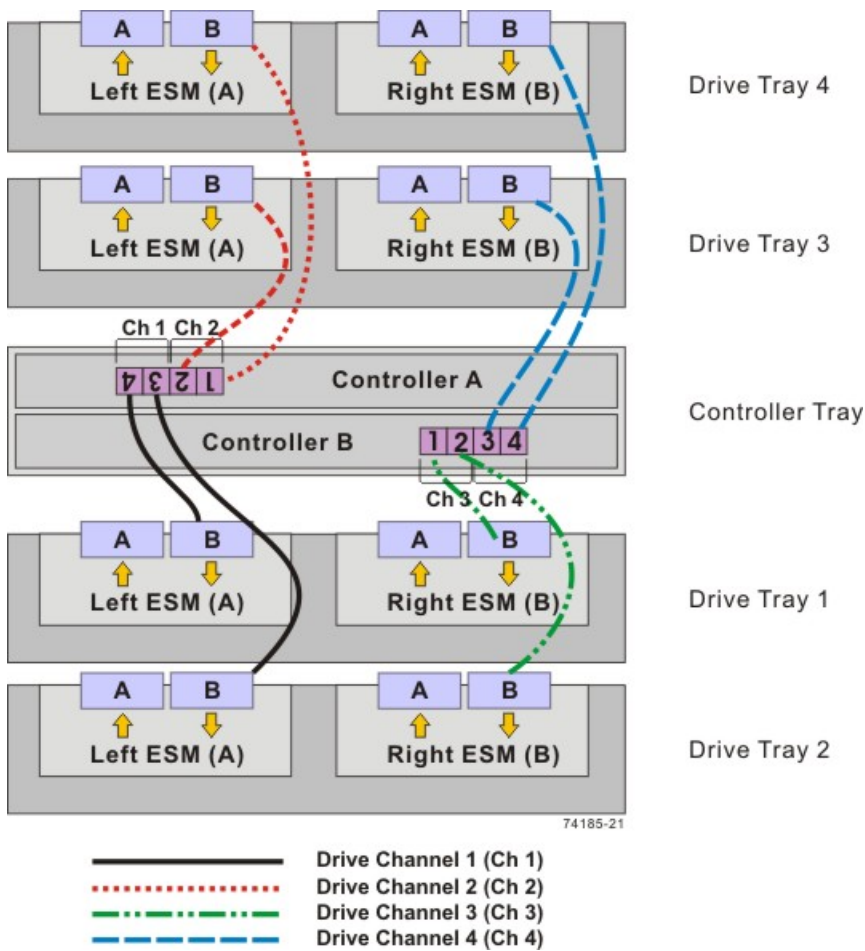

One CE6998 Controller Tray and Four Drive Trays

| Drive Channel | Connection Point | | Connection Point | |
|---------------|-------------------|--------------------------|-------------------|--------------------------|
| | Tray or Component | Port Number and Location | Tray or Component | Port Number and Location |
| 1 | Controller A | 4 | Drive tray 1 | Left ESM, port B |
| | Controller A | 3 | Drive tray 2 | Left ESM, port B |
| 2 | Controller A | 2 | Drive tray 3 | Left ESM, port B |
| | Controller A | 1 | Drive tray 4 | Left ESM, port B |
| 3 | Controller B | 1 | Drive tray 1 | Right ESM, port B |
| | Controller B | 2 | Drive tray 2 | Right ESM, port B |
| 4 | Controller B | 3 | Drive tray 3 | Right ESM, port B |

| Drive Channel | Connection Point | | Connection Point | |
|---------------|-------------------|--------------------------|-------------------|--------------------------|
| | Tray or Component | Port Number and Location | Tray or Component | Port Number and Location |
| | Controller B | 4 | Drive tray 4 | Right ESM, port B |



NOTE If you have drive trays with inverted ESM canisters, see [ESM Canister Arrangements](#).

One CE6998 Controller Tray and Eight Drive Trays

If you are cabling one CE6998 controller tray to eight drive trays, use the cabling topology described in the following table and figure.

One CE6998 Controller Tray and Eight Drive Trays

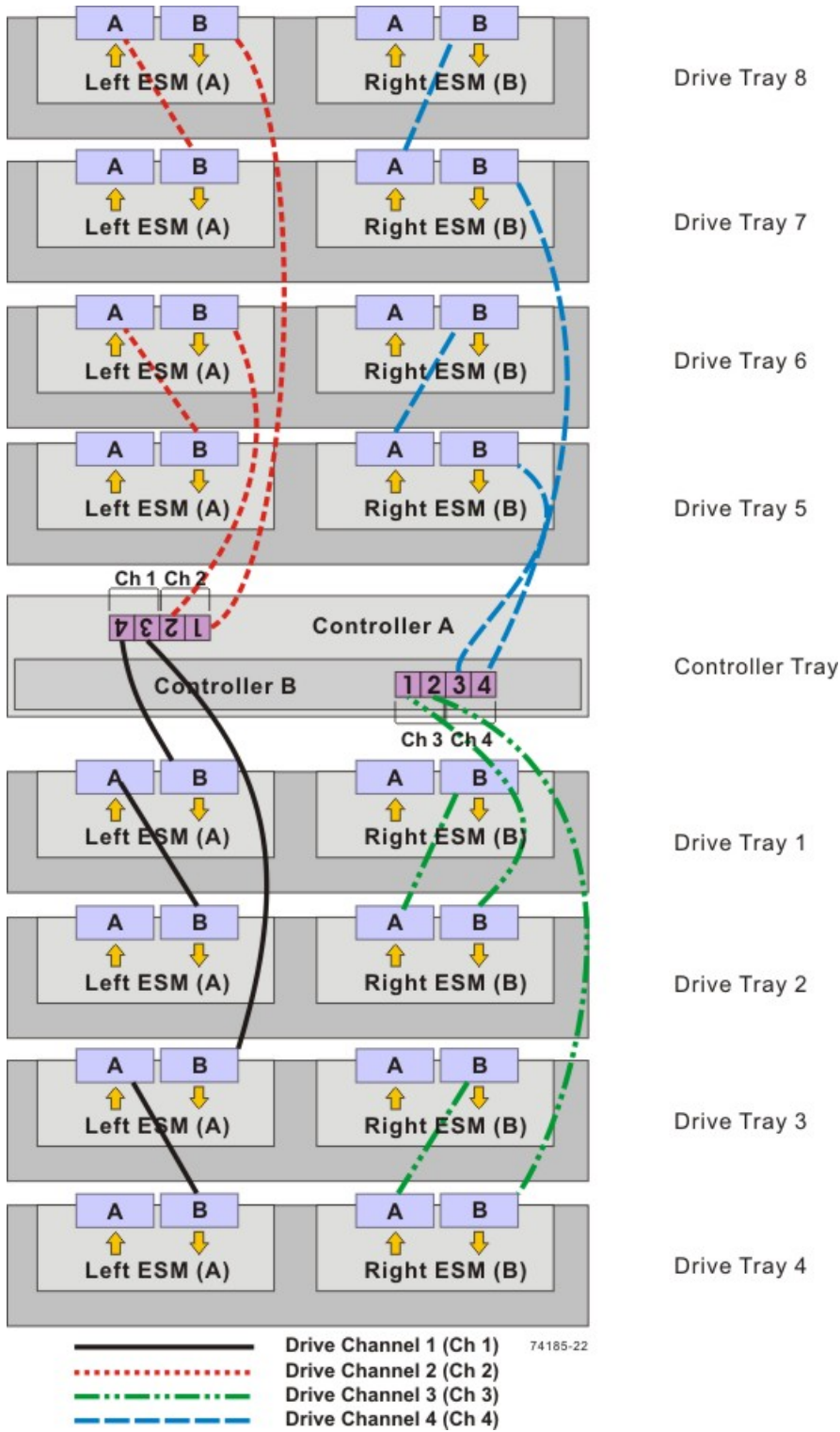

One CE6998 Controller Tray and Eight Drive Trays

| Drive Channel | Connection Point | | Connection Point | |
|---------------|-------------------|--------------------------|-------------------|--------------------------|
| | Tray or Component | Port Number and Location | Tray or Component | Port Number and Location |
| 1 | Controller A | 4 | Drive tray 1 | Left ESM, port B |
| | Drive tray 1 | | Drive tray 2 | Left ESM, port B |
| | Controller A | 3 | Drive tray 3 | Left ESM, port B |
| | Drive tray 3 | | Drive tray 4 | Left ESM, port B |
| 2 | Controller A | 2 | Drive tray 6 | Left ESM, port B |
| | Drive tray 6 | | Drive tray 5 | Left ESM, port B |
| | Controller A | 1 | Drive tray 8 | Left ESM, port B |
| | Drive tray 8 | | Drive tray 7 | Left ESM, port B |
| 3 | Controller B | 1 | Drive tray 2 | Right ESM, port B |
| | Drive tray 2 | | Drive tray 1 | Right ESM, port B |
| | Controller B | 2 | Drive tray 4 | Right ESM, port B |
| | Drive tray 4 | | Drive tray 3 | Right ESM, port B |
| 4 | Controller B | 3 | Drive tray 5 | Right ESM, port B |
| | Drive tray 5 | | Drive tray 6 | Right ESM, port B |
| | Controller B | 4 | Drive tray 7 | Right ESM, port B |
| | Drive tray 7 | | Drive tray 8 | Right ESM, port B |



NOTE If you have drive trays with inverted ESM canisters, see [ESM Canister Arrangements](#).

One CE6998 Controller Tray and Multiple Types of Drive Trays

If you are cabling more than one type of drive tray to the CE6998 controller tray, read these topics before you choose a cabling topology:

- Guidelines for Cabling FC2610 Drive Trays or FC4600 Drive Trays
- Guidelines for Cabling AT2655 Drive Trays

Follow these guidelines for cabling multiple types of drive trays to maximize performance and accessibility.

Guidelines for Cabling FC2610 Drive Trays or FC4600 Drive Trays

Follow these guidelines for cabling a topology with multiple types of drive trays, including the FC2610 drive trays or the FC4600 drive trays.

- If your storage array includes FC2610 drive trays or FC4600 drive trays, cable the FC2610 drive trays or the FC4600 drive trays so that they are the first devices on the drive channel (after controller A). The first device on the drive channel is distinguished by the fact that the left ESM of the first device is cabled directly to controller A of the controller tray. Because an optimal redundant cabling topology requires that the redundant drive channel be cabled in the opposite order, this same device will be the last in the drive channel when cabled to controller B.
- Evenly distribute the FC2610 drive trays or the FC4600 drive trays in pairs or multiples across redundant pairs of the available drive channels.
- Do not cable a single FC2610 drive tray or a single FC4600 drive tray on a drive channel unless it is the only FC2610 drive tray or FC4600 drive tray in the storage array.

Guidelines for Cabling AT2655 Drive Trays

Follow these guidelines for cabling a topology with multiple drive tray types, including AT2655 drive trays.

- If your storage array includes AT2655 drive trays, cable the AT2655 drive trays so that they are the last devices on the drive channel (from a top-down cabling perspective).
- Distribute AT2655 drive trays across redundant pairs of drive channels to equalize the number of drive trays on the available channels.

In the following figure, the FC2610 drive trays and the FC4600 drive trays are identified as SBODs (Switched Bunch of Disks). The AT2655 drive tray is identified as SATA (Serial Advanced Technology Attachment).



NOTE When you mix different types of drive trays, you must consider the total number of drives that are available in the final configuration of the storage array. For example, if you mix FC4600 drive trays with FC2610 drive trays, the total number of drives might be more than the maximum number that each drive channel can support.

One CE6998 Controller Tray and Multiple Types of Drive Trays

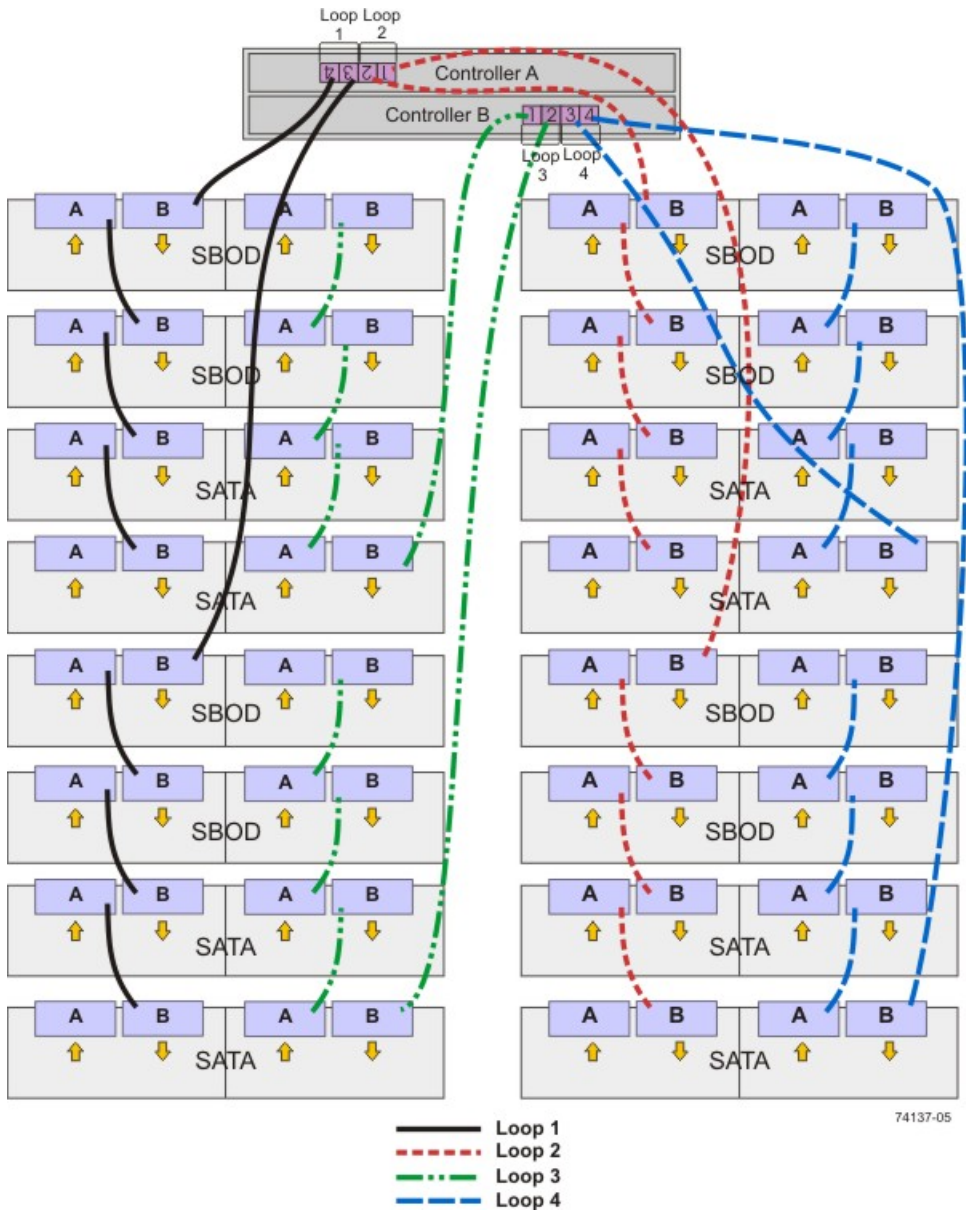

NOTE If you have drive trays with inverted ESM canisters, see [ESM Canister Arrangements](#).

Drive Cabling Topologies for the CE5400 Controller-Drive Trays

This section provides examples of drive cabling topologies for the CE5400 controller-drive trays. The CE5400 controller-drive tray models are: CE5400-12, CE5400-24, and the CE5400-60.

The CE5400 controller-drive trays can be cabled to DE1600 drive trays, DE5600 drive trays, DE6600 drive trays, or combinations of these three types of drive trays. For the High Performance Computing (HPC) configurations of the CE5400, the total number of drives in the storage array, including the drives in the controller-drive tray and those in all of the attached drive trays, must not exceed 240. For non-HPC configurations of the CE5400, the total number of drives in the storage array, including the drives in the

controller-drive tray and those in all of the attached drive trays, must not exceed 384. For all configurations of the CE5400, the total number of trays in the storage array, including the controller-drive tray and all of the attached drive trays, must not exceed 16.

Drive Cabling Topologies for the CE5400-24 Controller-Drive Tray and the CE5400-12 Controller-Drive Tray

The figures in this section show representative cabling configurations. The configurations shown guarantee that redundant data paths exist between the controller-drive tray and all attached drive trays in a storage array. The CE5400-24 controller-drive tray and the CE5400-12 controller-drive tray can be cabled to DE1600 drive trays, DE5600 drive trays, DE6600 drive trays, or various combinations of those three models of drive tray.

For any one controller-drive tray, you must not exceed the limit of 15 connected drive trays or the limit for the total number of drives in the storage array. The drive limit for the High Performance Computing (HPC) configuration is 240 drives. For non-HPC configurations, the limit is 384 drives. The drive limit includes drives installed in the controller-drive tray.

The following figure show the SAS ports on a DE1600 drive tray or a DE5600 drive tray. You may connect either of the SAS ports labeled SAS 1 and SAS 2 to the SAS expansion port on another drive tray or on a controller-drive tray. Do not make connections to both the SAS 1 port and the SAS 2 port on the same ESM.

SAS Ports on a DE1600 Drive Tray or a DE5600 Drive Tray

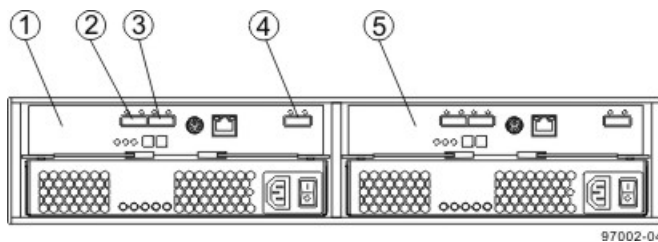

1. ESM A
2. SAS Port 1
3. SAS Port 2
4. SAS Expansion Port
5. ESM B

One CE5400-24 Controller-Drive Tray or CE5400-12 Controller-Drive Tray and One DE1600 Drive Tray or DE5600 Drive Tray

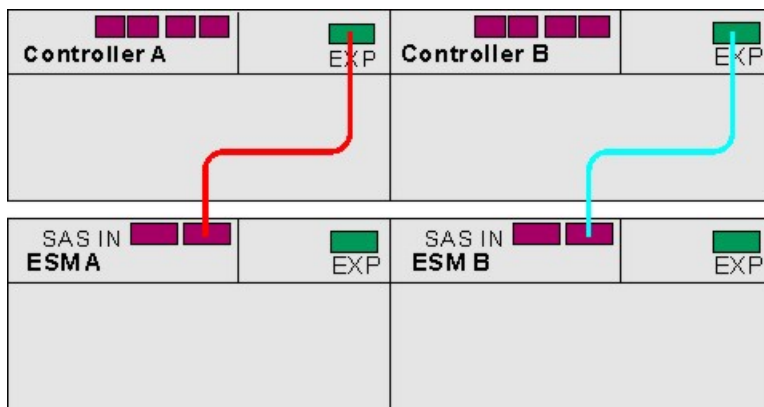

50012-03

One CE5400-24 Controller-Drive Tray or CE5400-12 Controller-Drive Tray and Two DE1600 Drive Trays or DE5600 Drive Trays

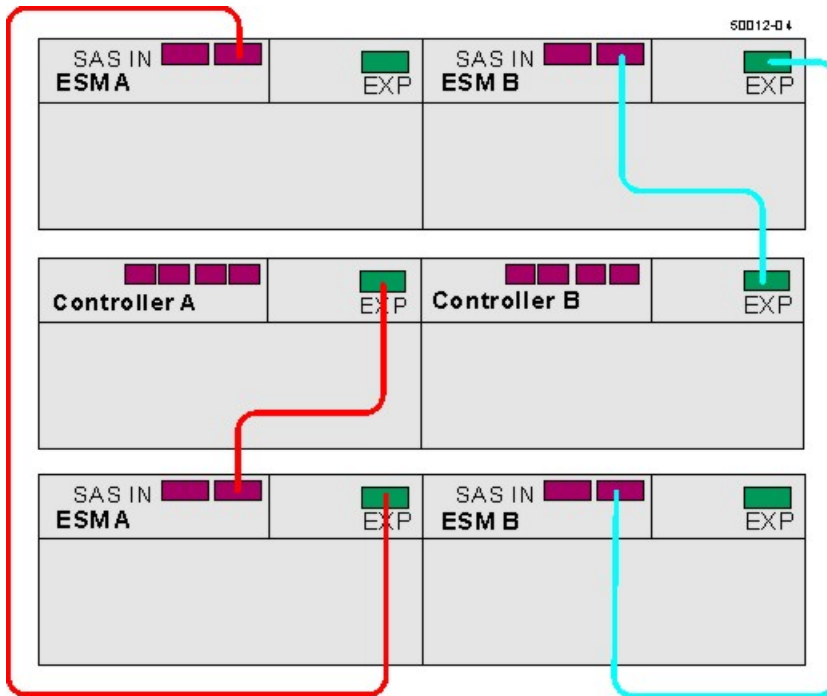

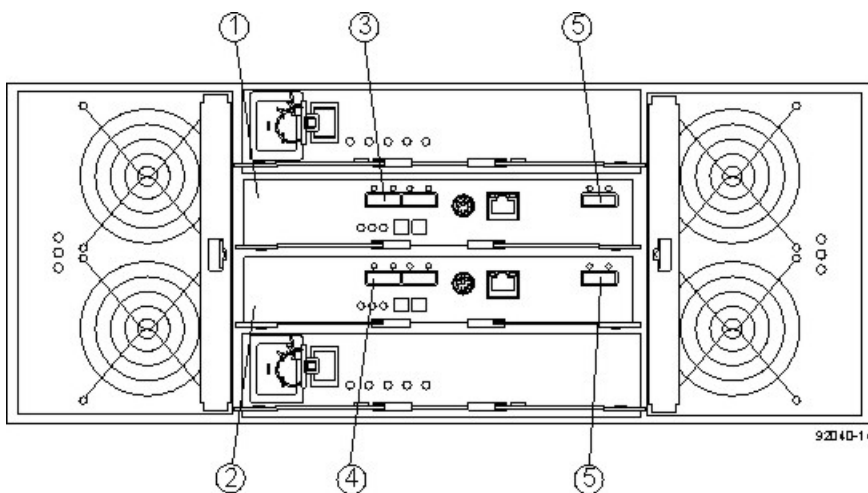

The following figures show the SAS ports on a DE6600 drive tray. You may connect either the left or right SAS port on an ESM to the SAS expansion port on another drive tray or on a controller-drive tray. Do not make connections to both the left and right SAS ports on the same ESM.

SAS Ports on a DE6600 Drive Tray



1. ESM A
2. ESM B
3. SAS In Ports
4. SAS In Ports
5. SAS Expansion Ports

 **WARNING (W15) Risk of bodily injury** – An empty tray weighs approximately 56.7 kg (125 lb). Three persons are required to safely move an empty tray. If the tray is populated with components, a mechanized lift is required to safely move the tray.

 **NOTE** The cabling pattern is independent of the physical location of the trays in the cabinet. If the storage array includes DE6600 drive trays, install those drive trays beginning from the bottom of the cabinet so that the cabinet does not become top-heavy. A top-heavy cabinet has a greater risk of falling over.

One CE5400-24 Controller-Drive Tray or CE5400-12 Controller-Drive Tray and One DE6600 Drive Tray

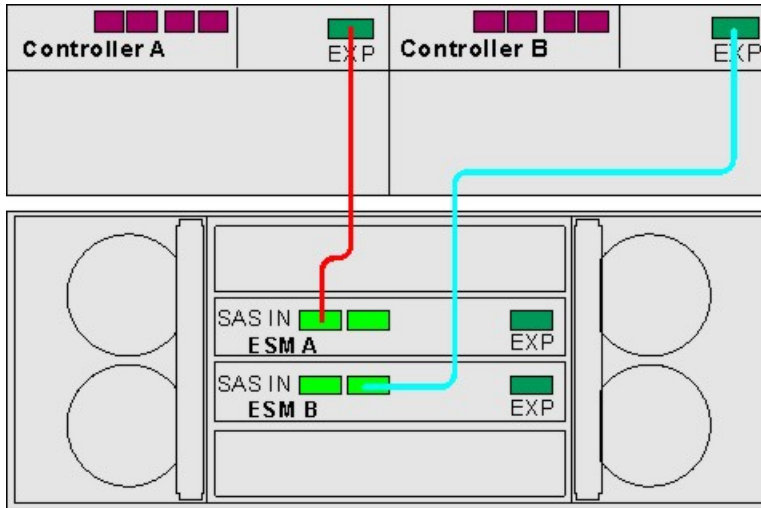

50012-01

One CE5400-24 Controller-Drive Tray or CE5400-12 Controller-Drive Tray and Two DE6600 Drive Trays

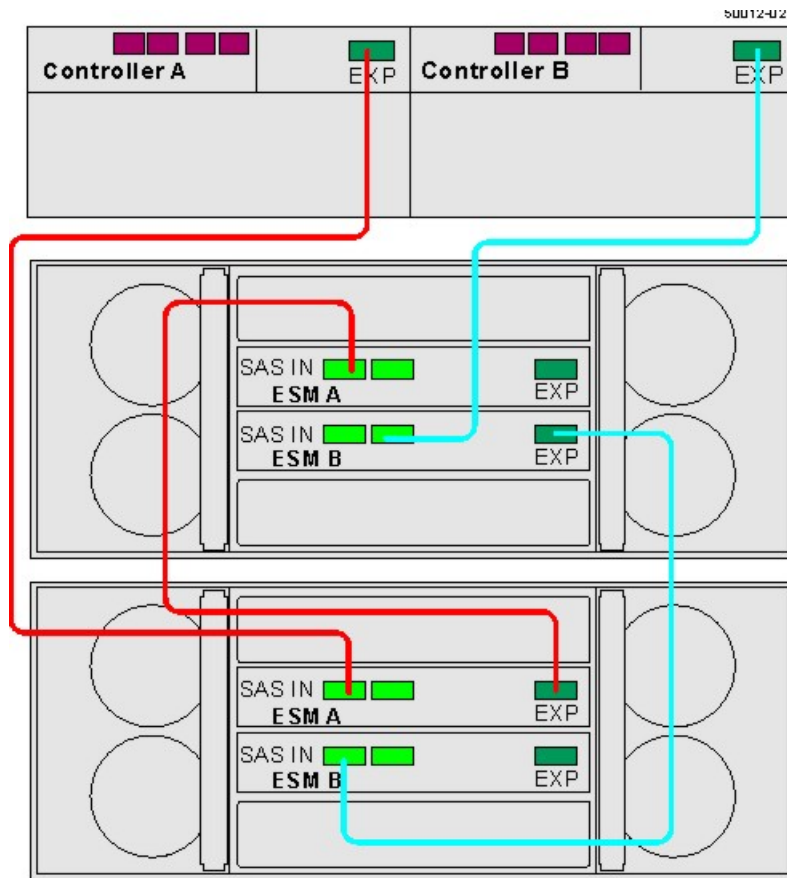

The following figure shows how the cabling pattern can be continued for additional drive trays until the 15 drive tray limit or the limit on the total number of drives in the storage array is reached. The figure uses the schematic representation for DE1600 drive trays or DE5600 drive trays. However, DE6600 drive trays can be included in the storage array as long as the same cabling pattern, connecting SAS expansion ports to SAS In ports, is followed.



IMPORTANT The cabling pattern is independent of the physical location of the trays in the cabinet. If the storage array includes DE6600 drive trays, install those drive trays beginning from the bottom of the cabinet so that the cabinet does not become top-heavy. A top-heavy cabinet has a greater risk of falling over.

One CE5400-24 Controller-Drive Tray or CE5400-12 Controller-Drive Tray and Seven or More Drive Trays

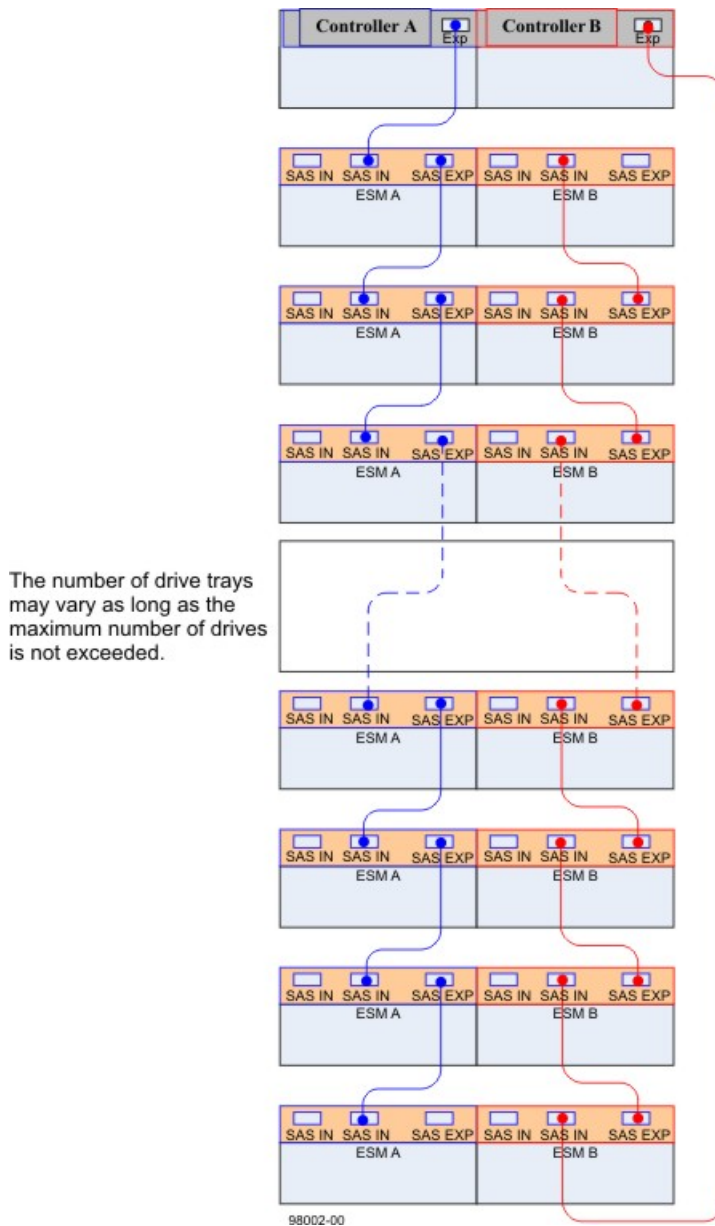

IMPORTANT The cabling pattern is independent of the physical location of the trays in the cabinet. If the controller-drive tray is installed in the middle of the cabinet, as shown in [Figure 3](#), the physical cabling pattern will be different from what is shown in [Figure 7](#), although the topology will be consistent. If the storage array includes DE6600 drive trays, install those drive trays beginning from the bottom of the cabinet so that the cabinet does not become top-heavy. A top-heavy cabinet has a greater risk of falling over.

Drive Cabling Topologies for the CE5400-60 Controller-Drive Tray

The figures in this section show representative cabling configurations. The configurations shown guarantee that redundant data paths exist between the controller-drive tray and all attached drive trays in a storage array. The CE5400-60 controller-drive tray can be cabled to DE1600 drive trays, DE5600 drive trays, DE6600 drive trays, or various combinations of those three models of drive tray.

WARNING (W15) Risk of bodily injury – An empty tray weighs approximately 56.7 kg (125 lb). Three persons are required to safely move an empty tray. If the tray is populated with components, a mechanized lift is required to safely move the tray.

NOTE Install the CE5400-60 controller-drive tray at the bottom of the cabinet so that the cabinet does not become top-heavy. A top-heavy cabinet has a greater risk of falling over.

For any one controller-drive tray, you must not exceed the limit of 15 connected drive trays or the limit for the total number of drives in the storage array. The drive limit for the High Performance Computing (HPC) configuration is 240 drives. For non-HPC configurations the limit is 384 drives. The drive limit includes drives installed in the controller-drive tray.

The following figures show the SAS ports on a DE1600 drive tray or a DE5600 drive tray. You may connect either the left or right SAS port on an ESM to the SAS expansion port on another drive tray or on a controller-drive tray. Do not make connections to both the left and right SAS ports on the same ESM.

SAS Ports on a DE1600 Drive Tray or a DE5600 Drive Tray

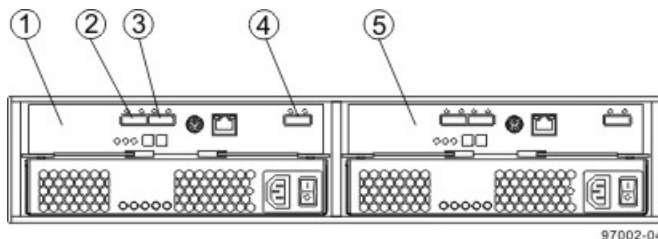

- 1. ESM A
- 2. SAS Port 1
- 3. SAS Port 2
- 4. SAS Expansion Port
- 5. ESM B

One CE5400-60 Controller-Drive Tray and One DE1600 Drive Tray or DE5600 Drive Tray

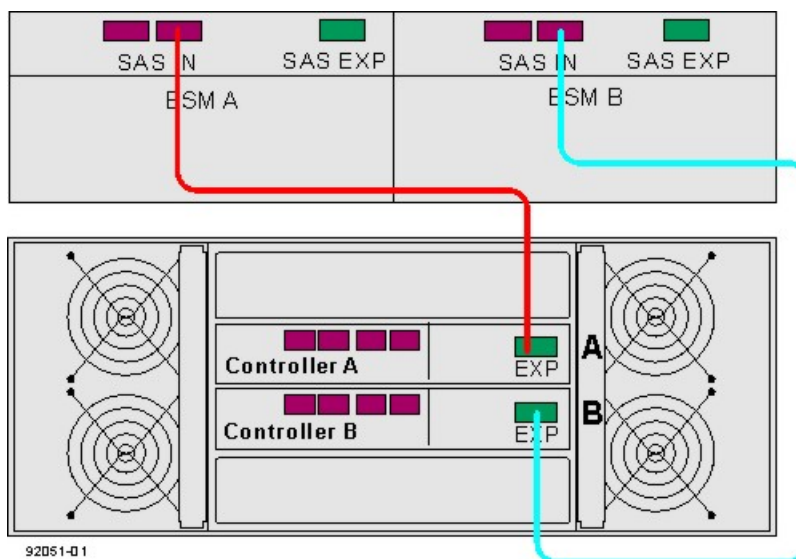

One CE5400-60 Controller-Drive Tray and Two DE1600 Drive Trays or DE5600 Drive Trays

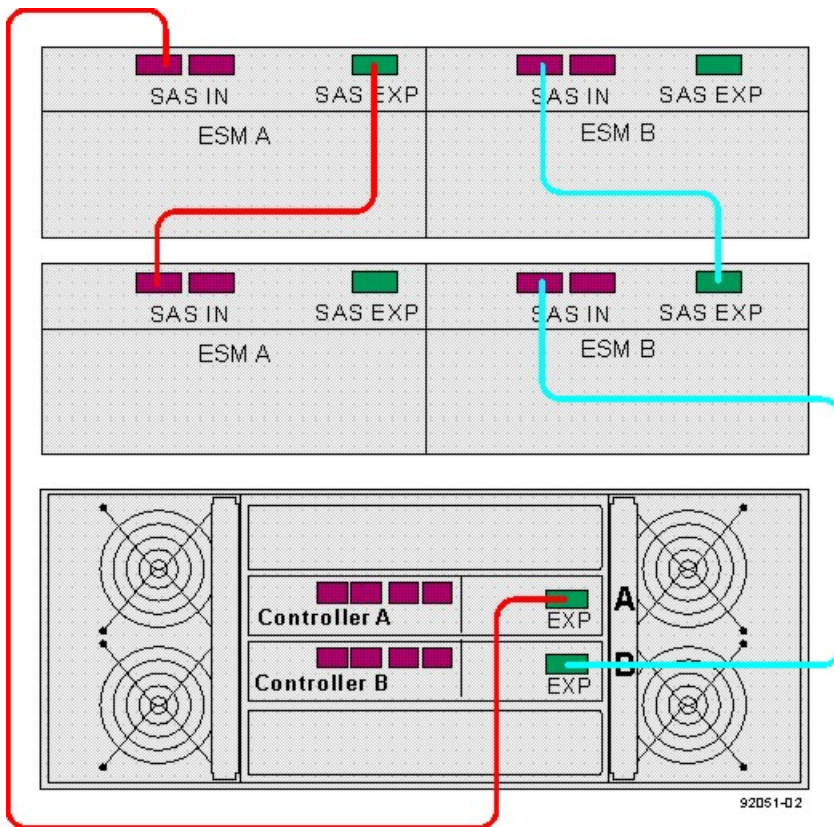

The following figures show the SAS ports on a DE6600 drive tray. You may connect either of the SAS ports labeled SAS 1 and SAS 2 to the SAS expansion port on another drive tray or on a controller-drive tray. Do not make connections to both the SAS 1 port and the SAS 2 port on the same ESM.



WARNING (W15) Risk of bodily injury – An empty tray weighs approximately 56.7 kg (125 lb). Three persons are required to safely move an empty tray. If the tray is populated with components, a mechanized lift is required to safely move the tray.



NOTE If the storage array includes DE6600 drive trays, install those drive trays beginning from the bottom of the cabinet so that the cabinet does not become top-heavy. A top-heavy cabinet has a greater risk of falling over.

SAS Ports on a DE6600 Drive Tray

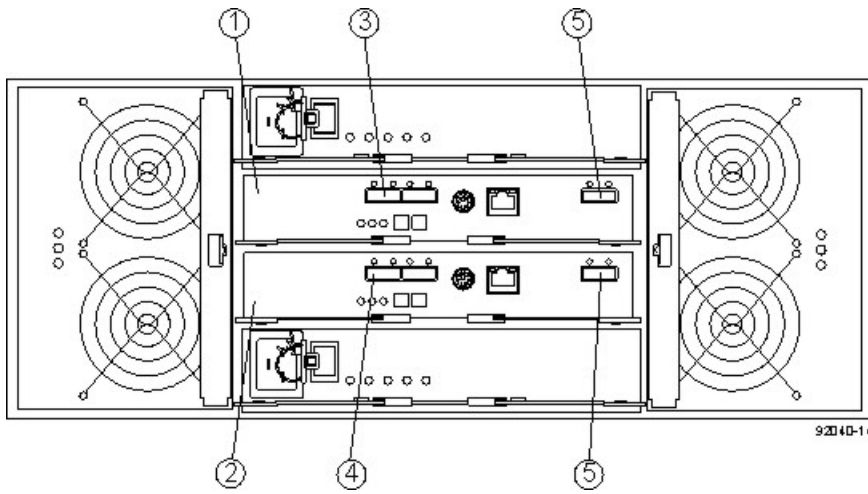

1. ESM A
2. ESM B
3. SAS In Port
4. SAS In Port
5. SAS Expansion Ports

One CE5400-60 Controller-Drive Tray and One DE6600 Drive Tray

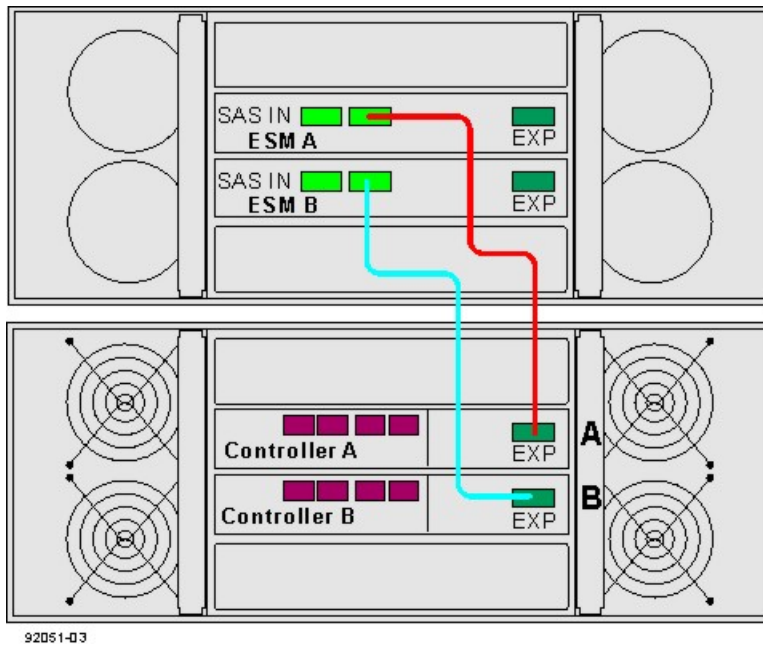

One CE5400-60 Controller-Drive Tray and Two DE6600 Drive Trays

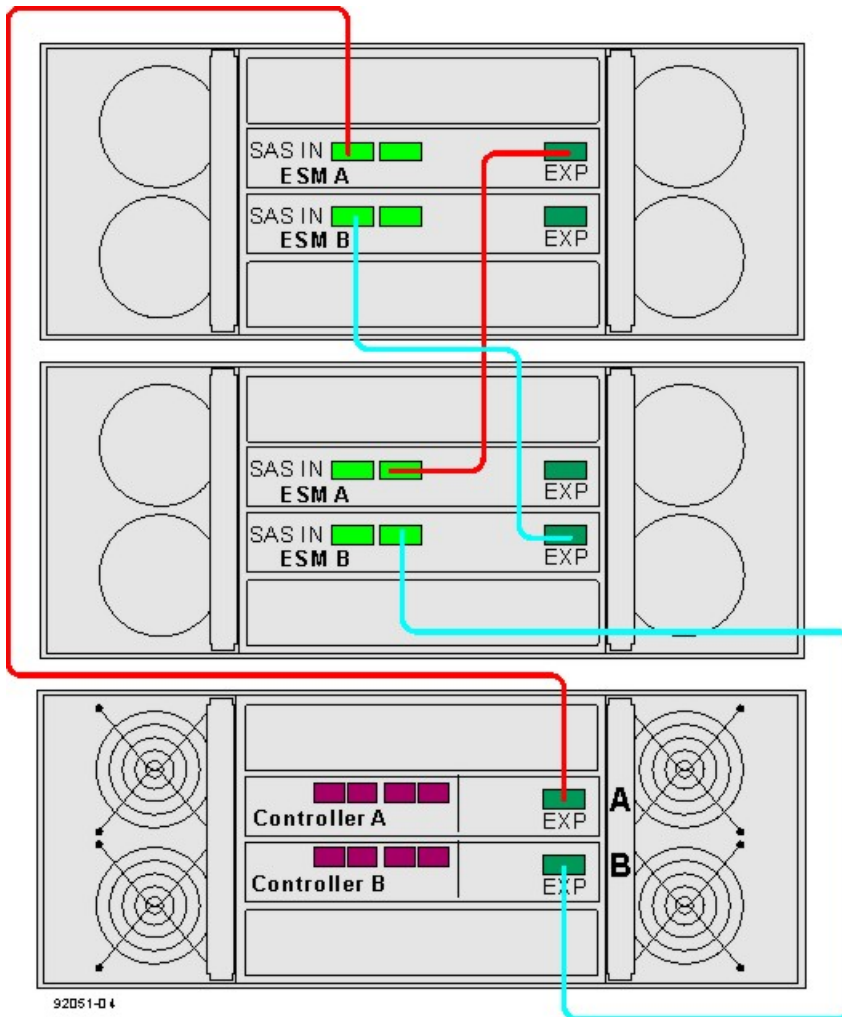

The following figure shows how the cabling pattern can be continued for additional drive trays until the 15 drive tray limit or the limit on the total number of drives in the storage array is reached. The figure uses the schematic representation for DE1600 drive trays or DE5600 drive trays. However, DE6600 drive trays can be included in the storage array as long as the same cabling pattern, connecting SAS expansion ports to SAS In ports, is followed.



NOTE The cabling pattern is independent of the physical location of the trays in the cabinet. If the storage array includes DE6600 drive trays, install those drive trays beginning from the bottom of the cabinet so that the cabinet does not become top-heavy. A top-heavy cabinet has a greater risk of falling over.

One CE5400-60 Controller-Drive Tray and Seven or More Drive Trays

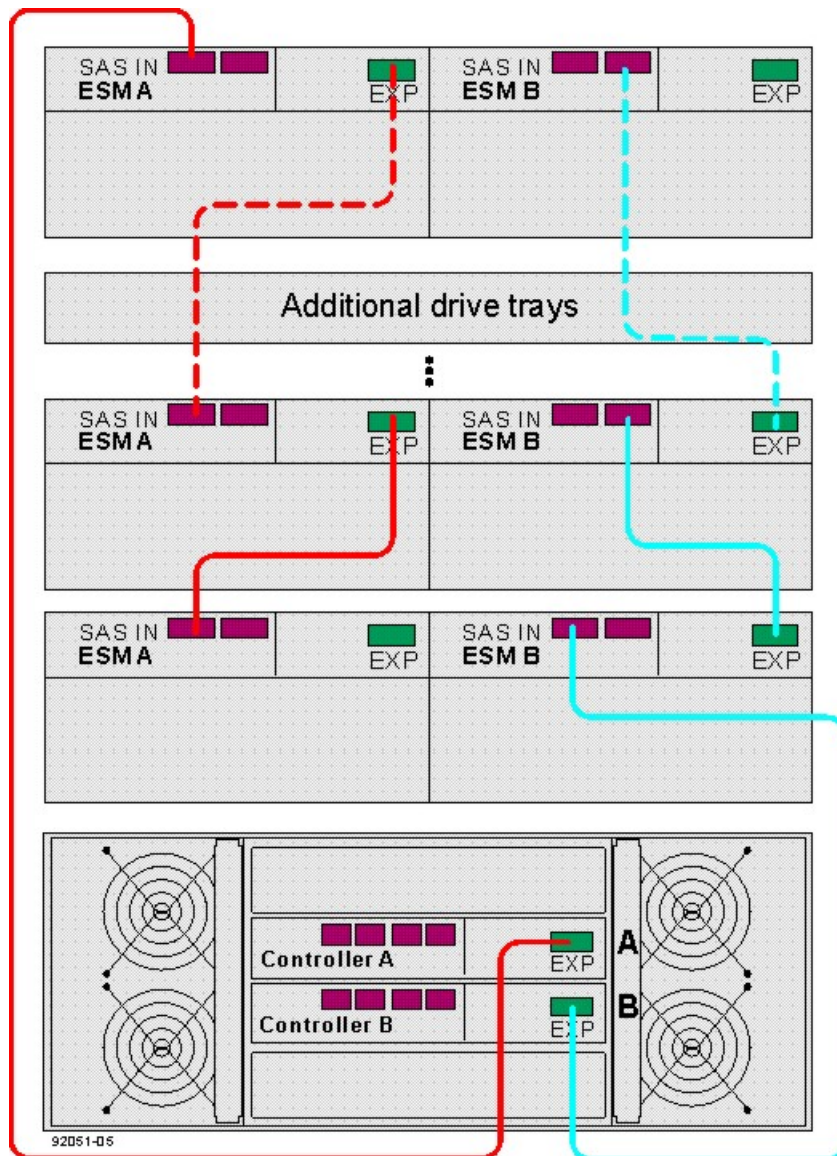

Drive Cabling Topologies for the CE4900 Controller-Drive Tray

This section provides examples of drive cabling topologies that can be used for cabling the CE4900 controller-drive tray to FC4600 drive trays. Depending on the number of drive trays that you need to connect, see the applicable figure for a cabling configuration. Each example provides redundant paths to the drives. The total number of drives in the storage array, including the drives in the controller-drive tray and those in the drive trays, must not exceed 112.

One CE4900 Controller-Drive Tray and One FC4600 Drive Tray

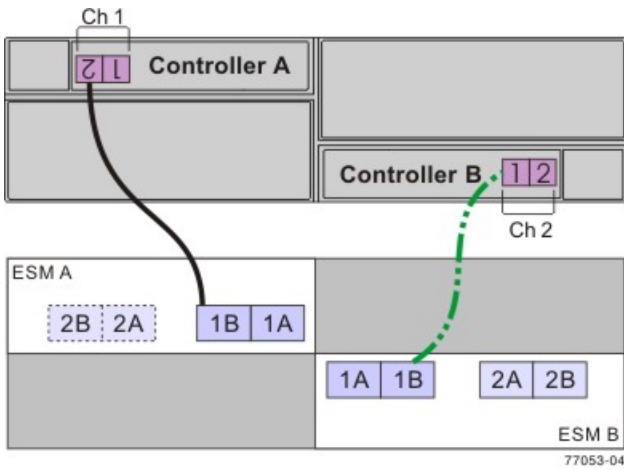

One CE4900 Controller-Drive Tray and Two FC4600 Drive Trays

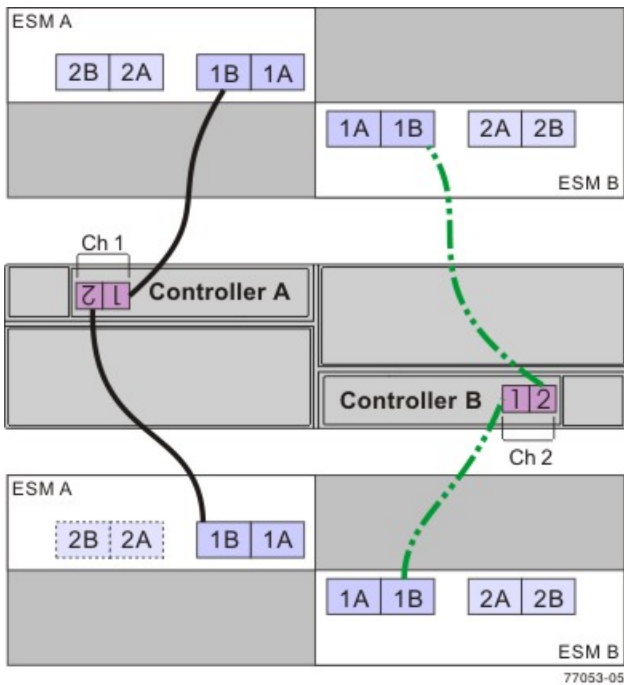

One CE4900 Controller-Drive Tray and Three FC4600 Drive Trays

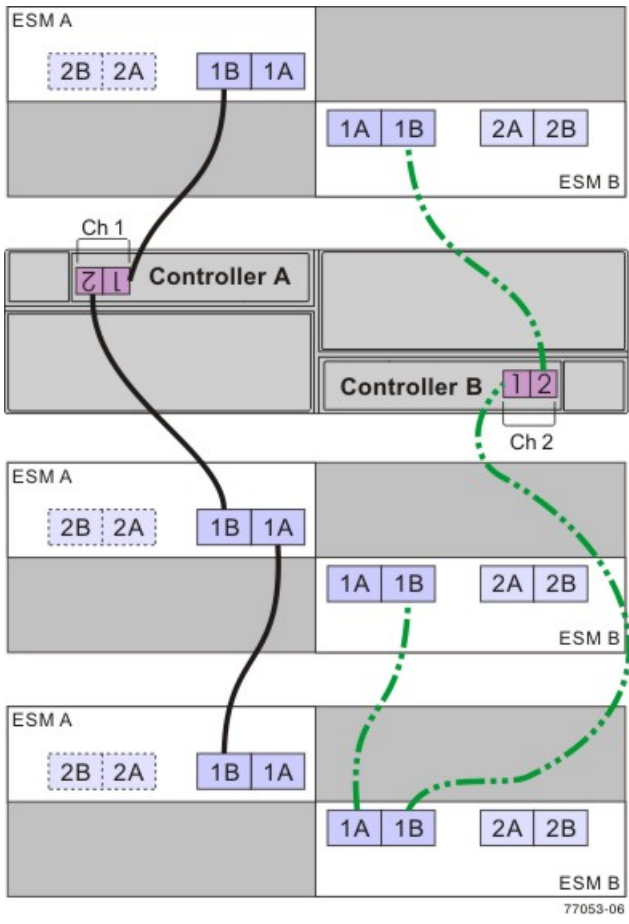

Drive Channel 1 (Ch 1)
 Drive Channel 2 (Ch 2)

One CE4900 Controller-Drive Tray and Four FC4600 Drive Trays

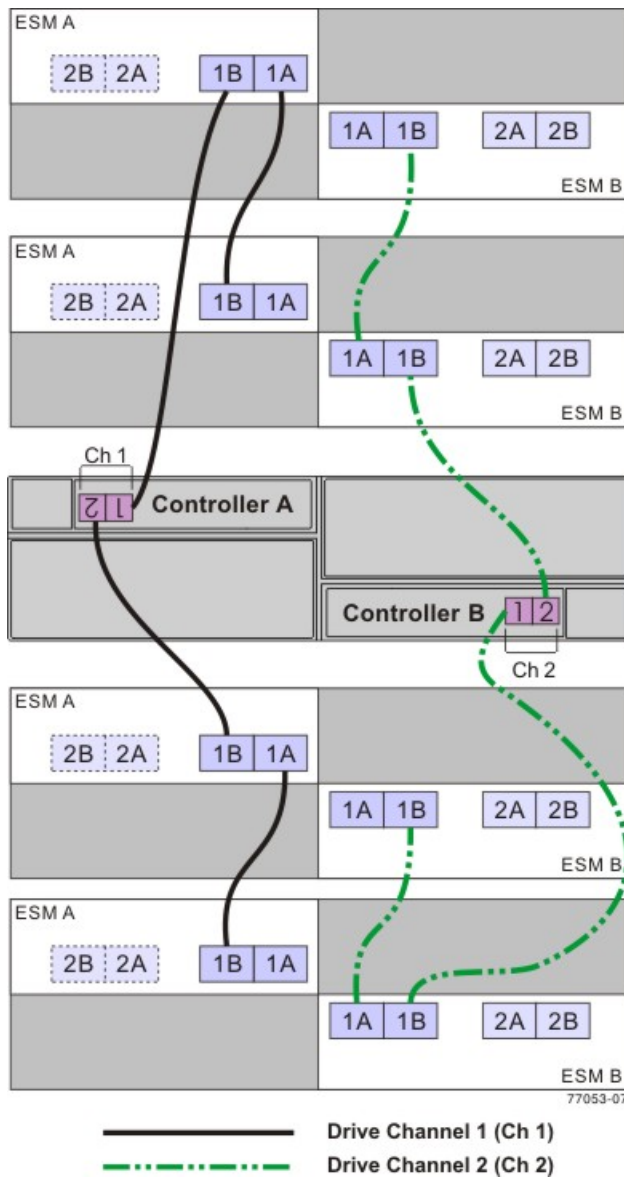

One CE4900 Controller-Drive Tray and Five FC4600 Drive Trays

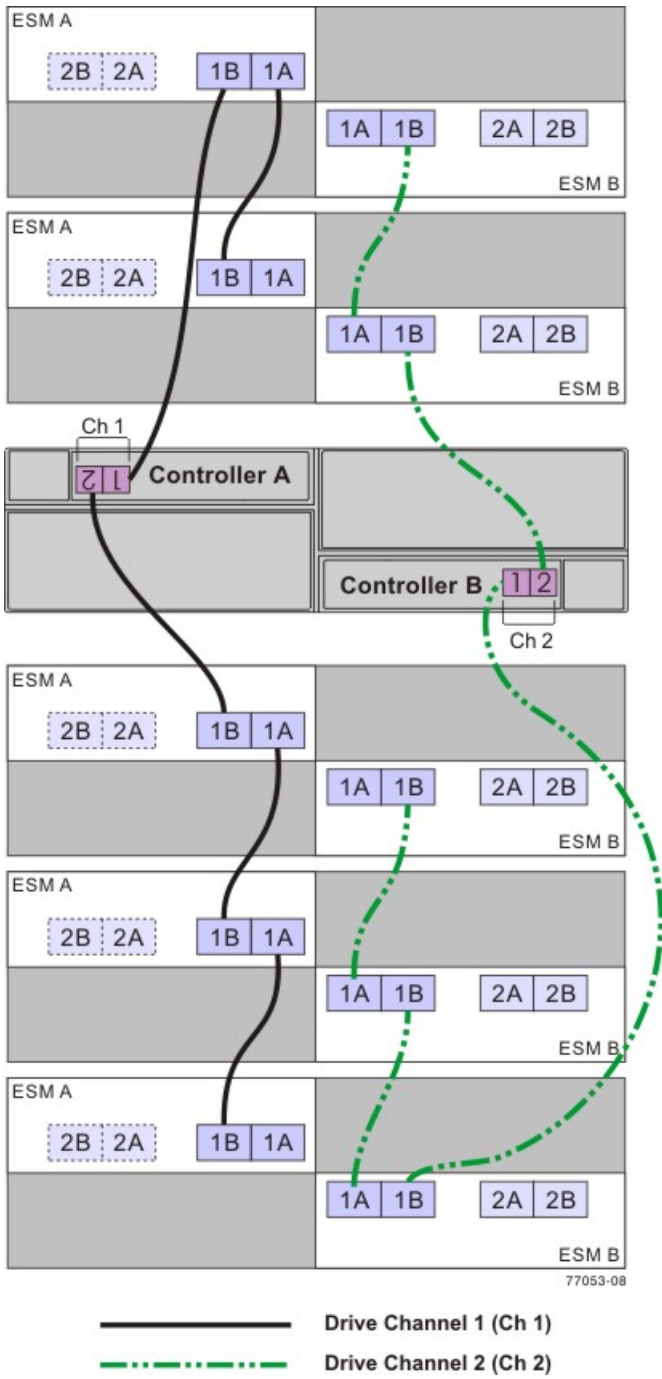

One CE4900 Controller-Drive Tray and Six FC4600 Drive Trays

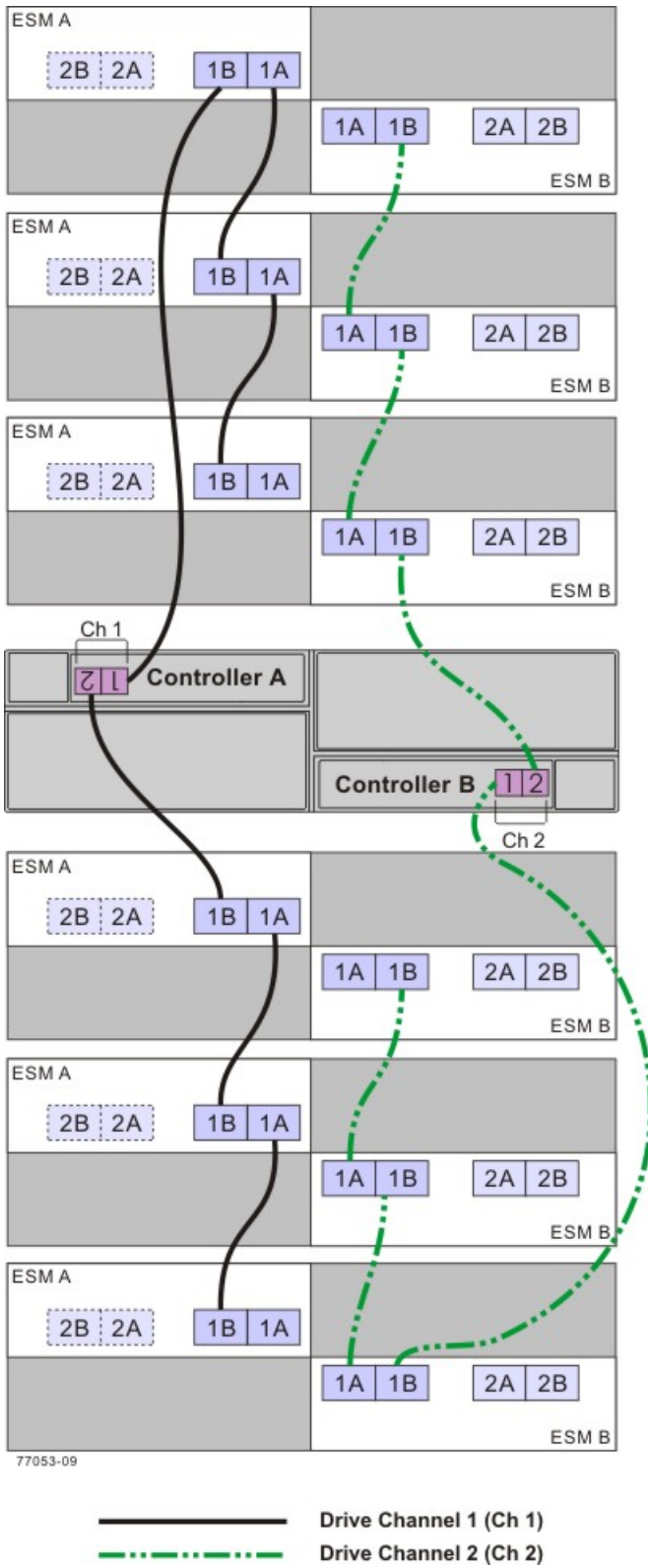

Drive Cabling Topologies for the CDE3994 Controller-Drive Tray and the CDE3992 Controller-Drive Tray

This section provides examples of drive cabling topologies that can be used for the CDE3994 controller-drive tray. The controllers on the lower-cost CDE3992 controller-drive tray have two host ports and two drive ports. The controllers on the higher-cost CDE3994 controller-drive tray have four host ports and two drive ports.

Each example provides redundant paths to the drives. If one of these examples is suitable for your hardware and application, complete the cabling connections as described by the tables. However you decide to implement your cabling, follow the recommendations in [Best Practices](#) to make sure that data has full availability.

One CDE3994 Controller-Drive Tray or CDE3992 Controller-Drive Tray and One Drive Tray

If you are cabling one CDE3994 controller-drive tray to one drive tray, and that drive tray has inverted ESM canisters, use the cabling topology described in the following table and figure.

One CDE3994 Controller-Drive Tray and One Drive Tray with Inverted ESMs

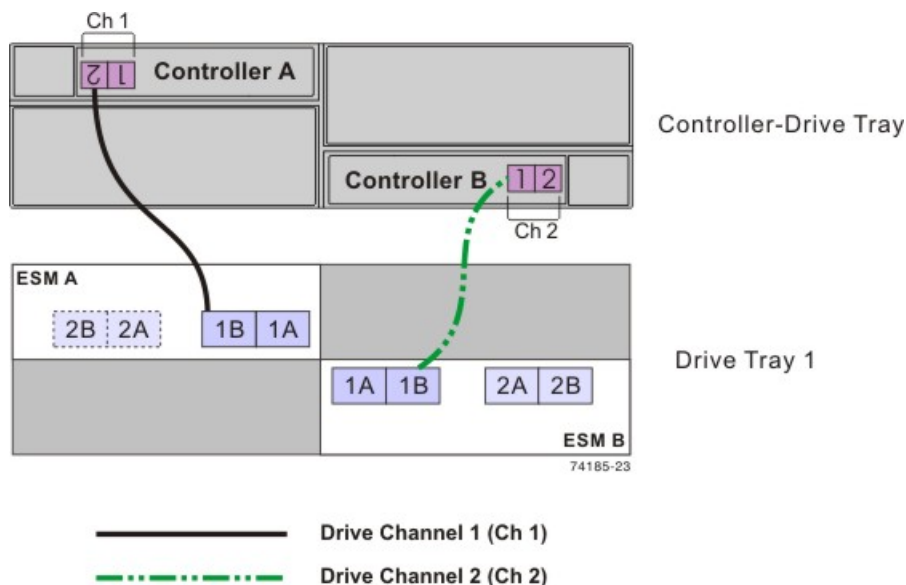

One CDE3994 Controller-Drive Tray and One Drive Tray with Inverted ESMs

| Drive Channel | Connection Point | | Connection Point | |
|---------------|-------------------|--------------------------|-------------------|--------------------------|
| | Tray or Component | Port Number and Location | Tray or Component | Port Number and Location |
| 1 | Controller A | 2 | Drive tray 1 | ESM A, port 1B |
| 2 | Controller B | 1 | Drive tray 1 | ESM B, port 1B |



NOTE If you have drive trays with inverted ESM canisters, see [ESM Canister Arrangements](#).

One CDE3994 Controller-Drive Tray or CDE3992 Controller-Drive Tray and Two Drive Trays

If you are cabling one CDE3994 controller-drive tray to two drive trays, and those drive trays have inverted ESM canisters, use the cabling topology shown in the following table and figure.

One CDE3994 Controller-Drive Tray and Two Drive Trays with Inverted ESMs

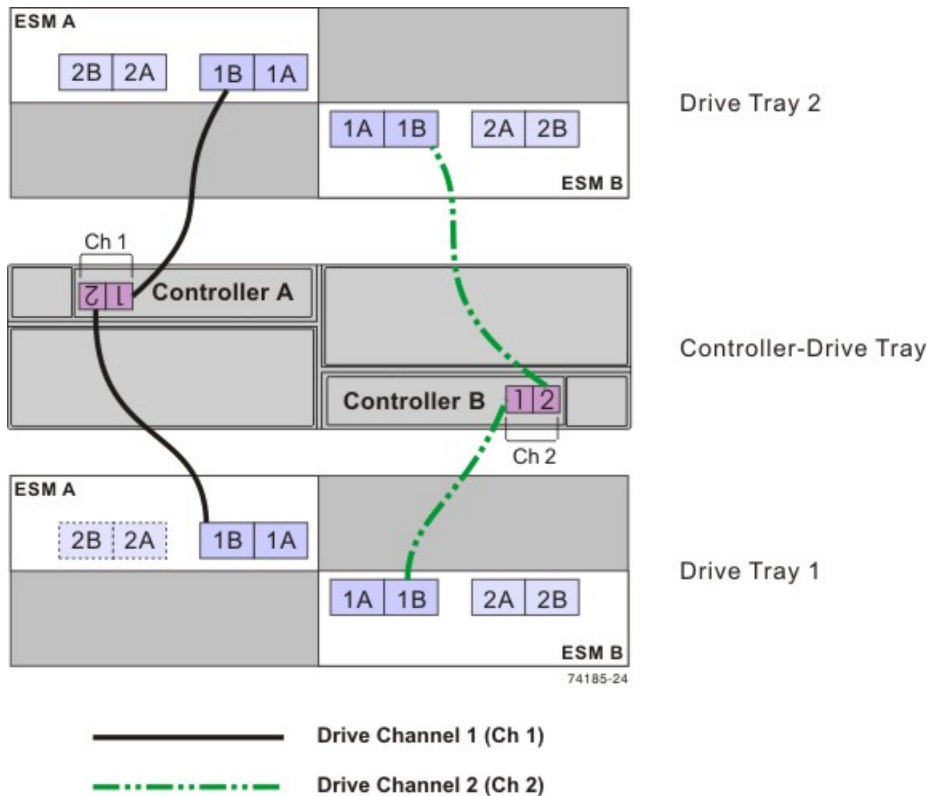

One CDE3994 Controller-Drive Tray and Two Drive Trays with Inverted ESMs

| Drive Channel | Connection Point | | Connection Point | |
|---------------|-------------------|--------------------------|-------------------|--------------------------|
| | Tray or Component | Port Number and Location | Tray or Component | Port Number and Location |
| 1 | Controller A | 1 | Drive tray 2 | ESM A, port 1B |
| | Controller A | 2 | Drive tray 1 | ESM A, port 1B |
| 2 | Controller B | 1 | Drive tray 1 | ESM B, port 1B |
| | Controller B | 2 | Drive tray 2 | ESM B, port 1B |

NOTE If you have drive trays with inverted ESM canisters, see [ESM Canister Arrangements](#).

One CDE3994 Controller-Drive Tray or CDE3992 Controller-Drive Tray and Three Drive Trays

If you are cabling one CDE3994 controller-drive tray to three drive trays, and those drive trays have inverted ESM canisters, use the cabling topology described in the following table and figure.

One CDE3994 Controller-Drive Tray and Three Drive Trays with Inverted ESMs

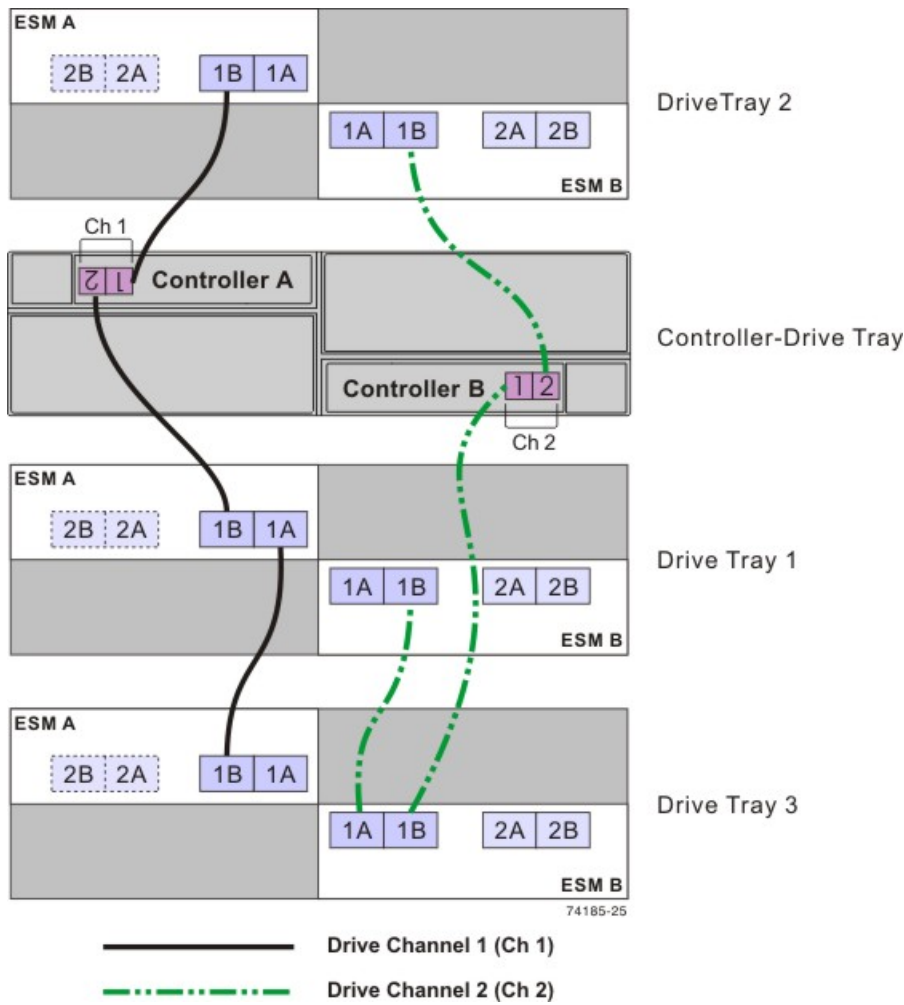

One CDE3994 Controller-Drive Tray and Three Drive Trays with Inverted ESMs

| Drive Channel | Connection Point | | Connection Point | |
|---------------|-------------------|--------------------------|-------------------|--------------------------|
| | Tray or Component | Port Number and Location | Tray or Component | Port Number and Location |
| 1 | Controller A | 1 | Drive tray 2 | ESM A, Port 1B |
| | Controller A | 2 | Drive tray 1 | ESM A, Port 1B |
| | Drive tray 1 | ESM B, Port 1A | Drive tray 3 | ESM A, Port 1B |
| 2 | Controller B | 1 | Drive tray 3 | ESM B, Port 1B |
| | Drive tray 3 | ESM B, Port 1A | Drive tray 1 | ESM B, Port 1B |
| | Controller B | 2 | Drive tray 2 | ESM B, Port 1B |

NOTE If you have drive trays with inverted ESM canisters, see [ESM Canister Arrangements](#).

One CDE3994 Controller-Drive Tray or CDE3992 Controller-Drive Tray and Four Drive Trays

If you are cabling one CDE3994 controller-drive tray to four drive trays, and those drive trays have inverted ESM canisters, use the cabling topology described in the following figure and table.

One CDE3994 Controller-Drive Tray and Four Drive Trays with Inverted ESMs

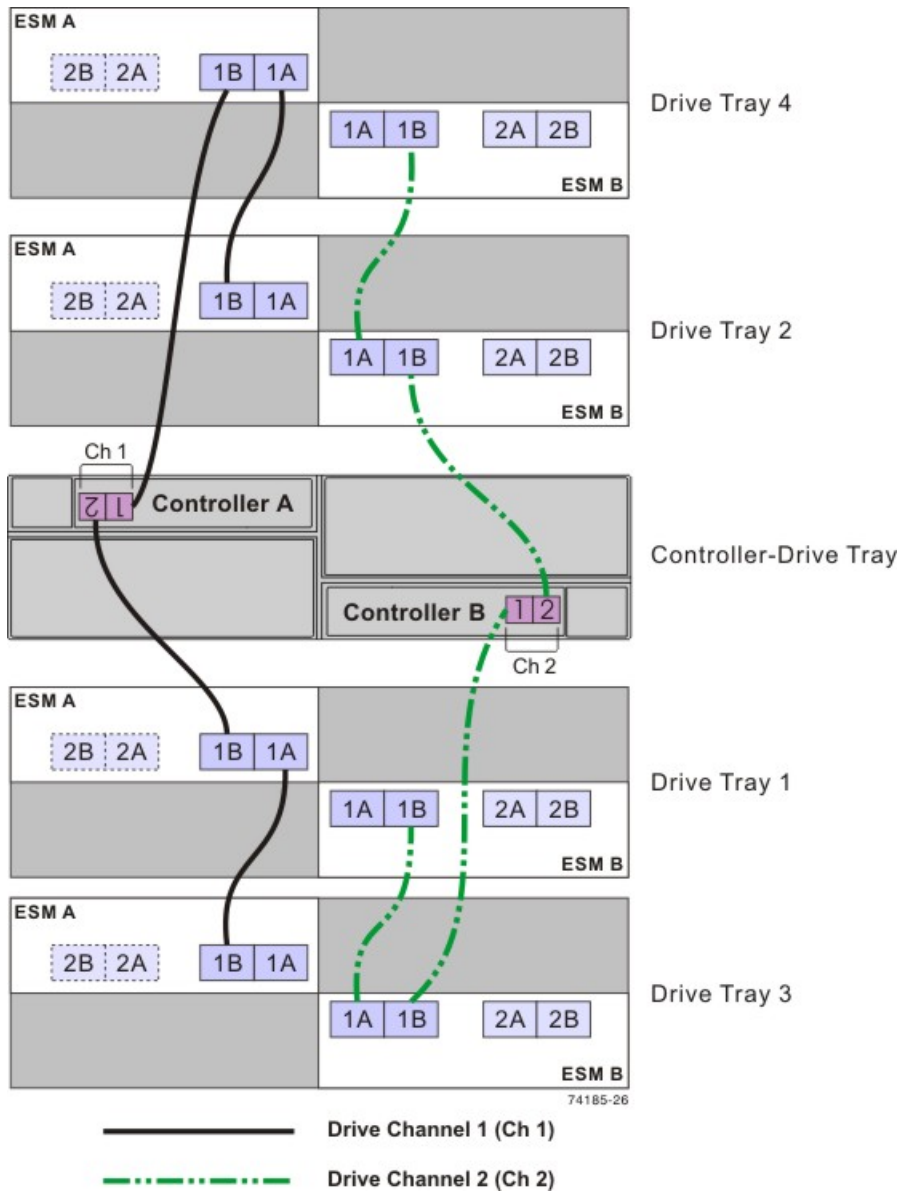

One CDE3994 Controller-Drive Tray and Four Drive Trays with Inverted ESMs

| Drive Channel | Connection Point | | Connection Point | |
|---------------|-------------------|--------------------------|-------------------|--------------------------|
| | Tray or Component | Port Number and Location | Tray or Component | Port Number and Location |
| 1 | Controller A | 1 | Drive tray 4* | ESM A, port 1B |
| | Drive tray 4* | ESM A, port 1A | Drive tray 2* | ESM A, port 1B |

| Drive Channel | Connection Point | | Connection Point | |
|--|-------------------|--------------------------|-------------------|--------------------------|
| | Tray or Component | Port Number and Location | Tray or Component | Port Number and Location |
| | Controller A | 2 | Drive tray 1* | ESM A, port 1B |
| | Drive tray 1* | ESM A, port 1A | Drive tray 3* | ESM A, port 1B |
| 2 | Controller B | 1 | Drive tray 3* | ESM B, port 1B |
| | Drive tray 3* | ESM B, port 1A | Drive tray 1* | ESM B, port 1B |
| | Controller B | 2 | Drive tray 2* | ESM B, port 1B |
| | Drive tray 2* | ESM B, port 1A | Drive tray 4* | ESM B, port 1B |
| *The firmware that controls the controller-drive tray automatically assigns drive tray tray IDs to the FC4600 drive trays that will usually not match the drive tray numbers shown in this table and preceding figure. The cabling is not affected by the assignment of drive tray tray IDs by the firmware. | | | | |



NOTE If you have drive trays with inverted ESM canisters, see [ESM Canister Arrangements](#).

One CDE3994 Controller-Drive Tray or CDE3992 Controller-Drive Tray and Five Drive Trays

If you are cabling one CDE3994 controller-drive tray to five drive trays, and those drive trays have inverted ESM canisters, use the cabling topology described in the following figure and table.

One CDE3994 Controller-Drive Tray and Five Drive Trays with Inverted ESMs

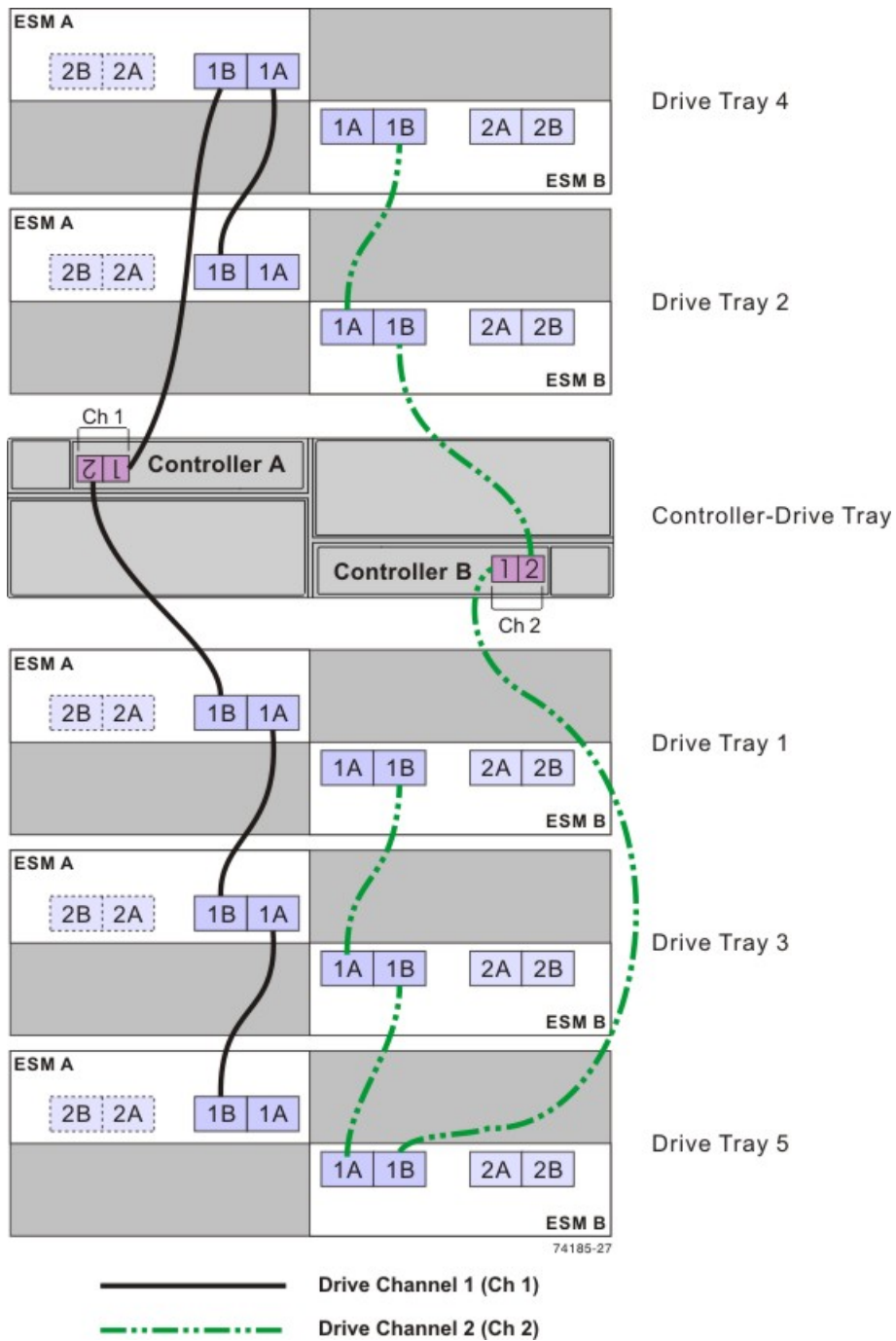

One CDE3994 Controller-Drive Tray and Five Drive Trays with Inverted ESMs

| Drive Channel | Connection Point | | Connection Point | |
|---------------|-------------------|--------------------------|-------------------|--------------------------|
| | Tray or Component | Port Number and Location | Tray or Component | Port Number and Location |
| 1 | Controller A | 1 | Drive tray 4 | ESM A, port 1B |

| Drive Channel | Connection Point | | Connection Point | |
|---------------|-------------------|--------------------------|-------------------|--------------------------|
| | Tray or Component | Port Number and Location | Tray or Component | Port Number and Location |
| | Drive tray 4 | ESM A, port 1A | Drive tray 2 | ESM A, port 1B |
| | Controller A | 2 | Drive tray 1 | ESM A, port 1B |
| | Drive tray 1 | ESM A, port 1A | Drive tray 3 | ESM A, port 1B |
| | Drive tray 3 | ESM A, port 1A | Drive tray 5 | ESM A, port 1B |
| 2 | Controller B | 1 | Drive tray 5 | ESM B, port 1B |
| | Drive tray 5 | ESM B, port 1A | Drive tray 3 | ESM B, port 1B |
| | Drive tray 3 | ESM B, port 1A | Drive tray 1 | ESM B, port 1B |
| | Controller B | 2 | Drive tray 2 | ESM B, port 1B |
| | Drive tray 2 | ESM B, port 1A | Drive tray 4 | ESM B, port 1B |

 **NOTE** If you have drive trays with inverted ESM canisters, see [ESM Canister Arrangements](#).

One CDE3994 Controller-Drive Tray or CDE3992 Controller-Drive Tray and Six Drive Trays

If you are cabling one CDE3994 controller-drive tray to six drive trays, and those drive trays have inverted ESM canisters, use the cabling topology shown in the following table and figure.

 **NOTE** The CDE3994 controller-drive tray supports a maximum of seven drive trays. However, if you are using the FC4600 drive tray in your configuration, plan for a limit of six FC4600 drive trays. Seven FC4600 drive trays fully populated with drives exceed the maximum number of drives supported on a single drive channel.

One CDE3994 Controller-Drive Tray and Six Drive Trays with Inverted ESMs

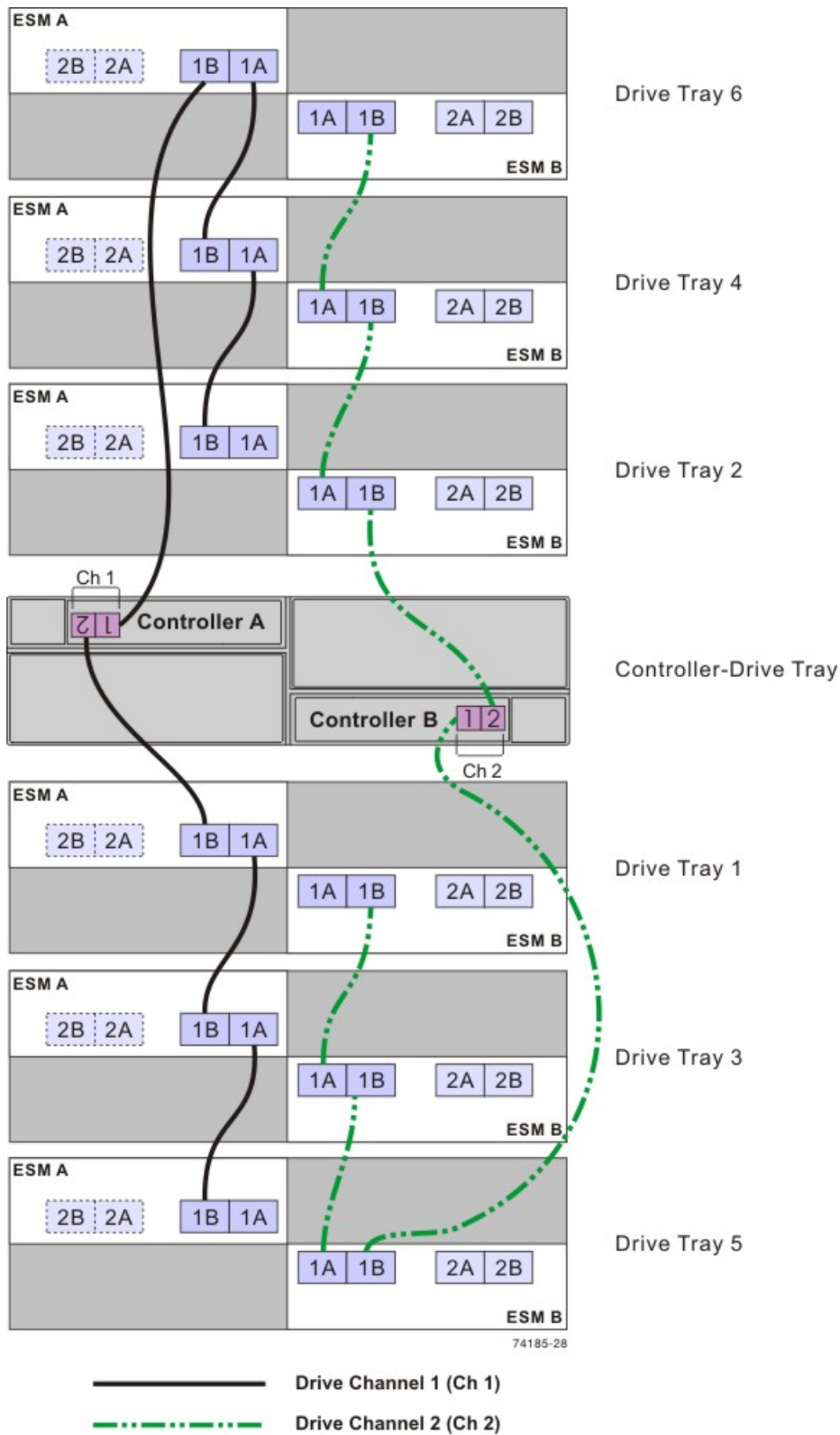

One CDE3994 Controller-Drive Tray and Six Drive Trays with Inverted ESMs

| Drive Channel | Connection Point | | Connection Point | |
|---|-------------------|--------------------------|-------------------|--------------------------|
| | Tray or Component | Port Number and Location | Tray or Component | Port Number and Location |
| 1 | Controller A | 1 | Drive tray 6* | ESM A, port 1B |
| | Drive tray 6* | ESM A, port 1A | Drive tray 4* | ESM A, port 1B |
| | Drive tray 4* | ESM A, port 1A | Drive tray 2* | ESM A, port 1B |
| | Controller A | 2 | Drive tray 1* | ESM A, port 1B |
| | Drive tray 1* | ESM A, port 1A | Drive tray 3* | ESM A, port 1B |
| | Drive tray 3* | ESM A, port 1A | Drive tray 5* | ESM A, port 1B |
| 2 | Controller B | 1 | Drive tray 5* | ESM B, port 1B |
| | Drive tray 5* | ESM B, port 1A | Drive tray 3* | ESM B, port 1B |
| | Drive tray 3* | ESM B, port 1A | Drive tray 1* | ESM B, port 1B |
| | Controller B | 2 | Drive tray 2* | ESM B, port 1B |
| | Drive tray 2* | ESM B, port 1A | Drive tray 4* | ESM B, port 1B |
| | Drive tray 4* | ESM B, port 1A | Drive tray 6* | ESM B, port 1B |
| *The firmware for the controller-drive tray automatically assigns tray IDs to the FC4600 drive trays. Those tray IDs usually will not match the drive tray numbers shown in this table and in the preceding figure. The cabling pattern is not affected by the assignment of drive tray tray IDs by the firmware. | | | | |



NOTE If you have drive trays with inverted ESM canisters, see [ESM Canister Arrangements](#).

One CDE3994 Controller-Drive Tray or CDE3992 Controller-Drive Tray and Multiple Types of Drive Trays

If you are cabling more than one type of drive tray to the CDE3994 controller-drive tray, be sure to read [Cabling for Drive Trays That Support Loop Switch Technology](#).

Follow these guidelines for cabling multiple types of drive trays to maximize performance and accessibility. (The first device on the drive channel is distinguished by the fact that the left ESM of the first device is cabled directly to controller A of the controller tray or controller-drive tray. Because an optimal redundant cabling topology requires that the redundant drive channel be cabled in the opposite order, this same device will be the last in the drive channel when cabled to controller B.)

The following figure provides an example of how flexible the cabling can be when you use a CDE3994 controller-drive tray as the controller. The firmware is able to detect, and correctly handle, combinations of drive trays with both side-by-side ESMs and inverted ESMs. This feature allows you to easily add new drive trays to your storage environment, while continuing to take advantage of pre-existing drive trays that you own.

If your storage array includes AT2655 drive trays, it is still advisable to cable the AT2655 drive trays so that they are the last devices on the drive channel (farthest from controller A).



NOTE When you mix different types of drive trays, you must consider the total number of drives that are available in the final configuration of the storage array. For example, if you mix FC4600 drive trays with FC2610 drive trays, the total number of drives might be more than the maximum number that each drive channel can support.

One CDE3994 Controller-Drive Tray and Multiple Types of Drive Trays

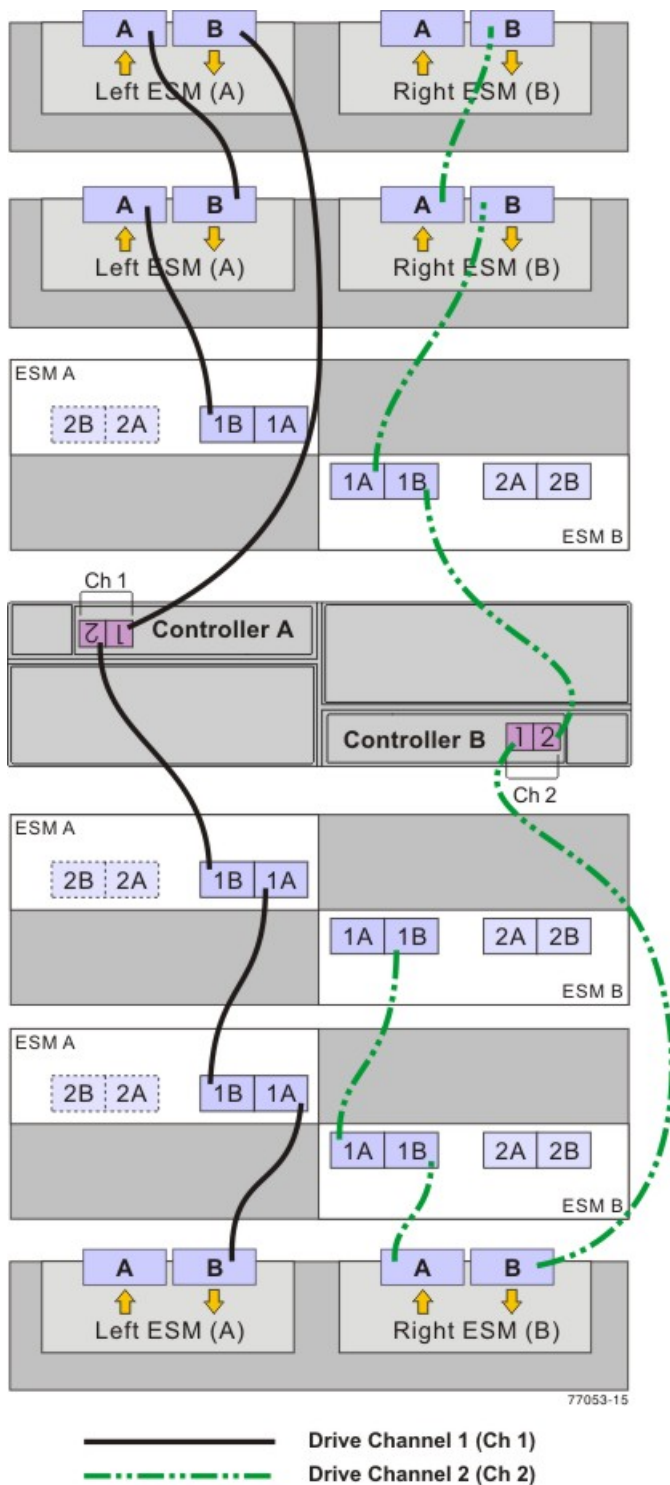

Drive Cabling Topologies for the CE2600 Controller-Drive Tray

This section provides examples of drive cabling topologies for the CE2600 controller-drive tray. The CE2600 controller-drive tray can be cabled to DE1600 drive trays, DE5600 drive trays, or combinations of these two drive trays. The total number of drives in the storage array, including the drives in the controller-drive tray and those in the drive trays, must not exceed 192.

NOTE Simplex systems do not provide redundant connections to drive trays. If a connection or an environmental services monitor (ESM) fails, all drive trays that connect to the controller-drive tray indirectly through the failed connection or drive tray will become inaccessible.

Drive Cabling Topologies for the CE2600 Controller-Drive Tray With DE1600 Drive Trays or DE5600 Drive Trays

Depending on the number of drive trays that you need to connect, see the applicable figure for a cabling topology. Each example shows a duplex controller-drive tray configuration with redundant paths to the drive trays. For a simplex controller-drive tray configuration, use the cabling topology shown for controller A in the applicable figure.

NOTE The following figures shows the SAS ports on a DE1600 drive tray or a DE5600 drive tray. You may connect either of the SAS ports labeled SAS 1 and SAS 2 to the SAS expansion port on another drive tray or on a controller-drive tray. You should not make connections to both the SAS 1 port and the SAS 2 port on the same ESM.

SAS Ports on a DE1600 Drive Tray or a DE5600 Drive Tray

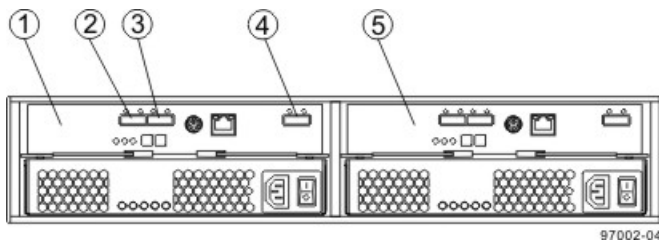

1. ESM A
2. SAS Port 1
3. SAS Port 2
4. SAS Expansion Port
5. ESM B

One CE2600 Controller-Drive Tray and One Drive Tray

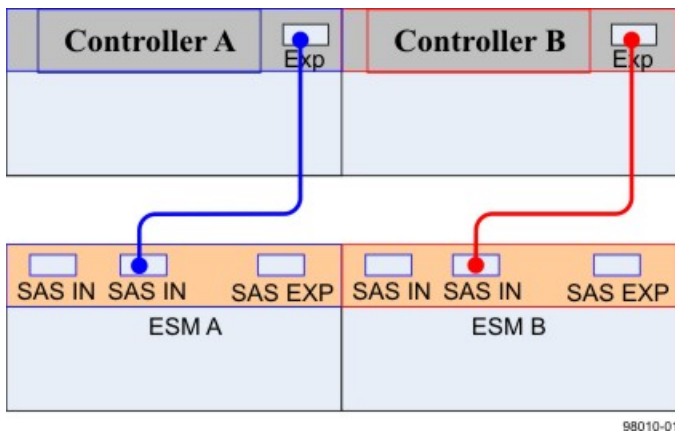

One CE2600 Controller-Drive Tray and Two Drive Trays

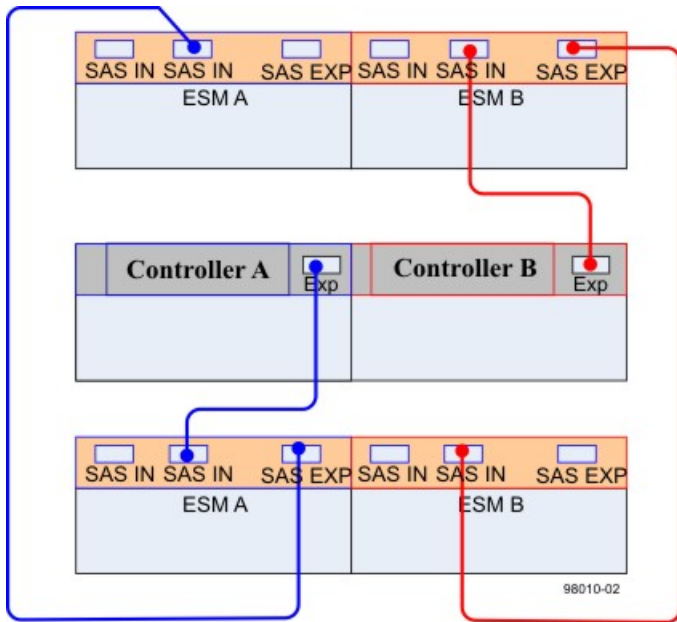

One CE2600 Controller-Drive Tray and Three Drive Trays

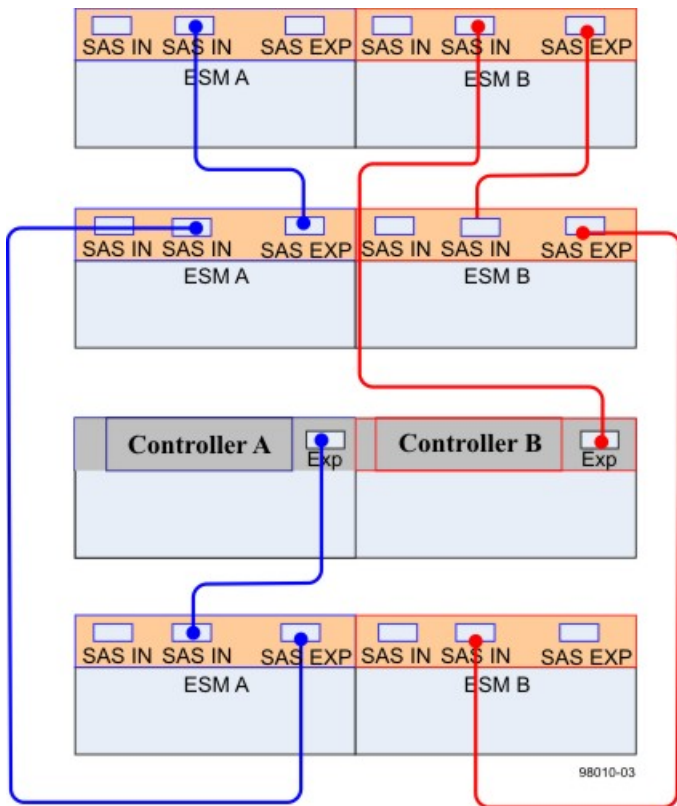

One CE2600 Controller-Drive Tray and Eight Drive Trays

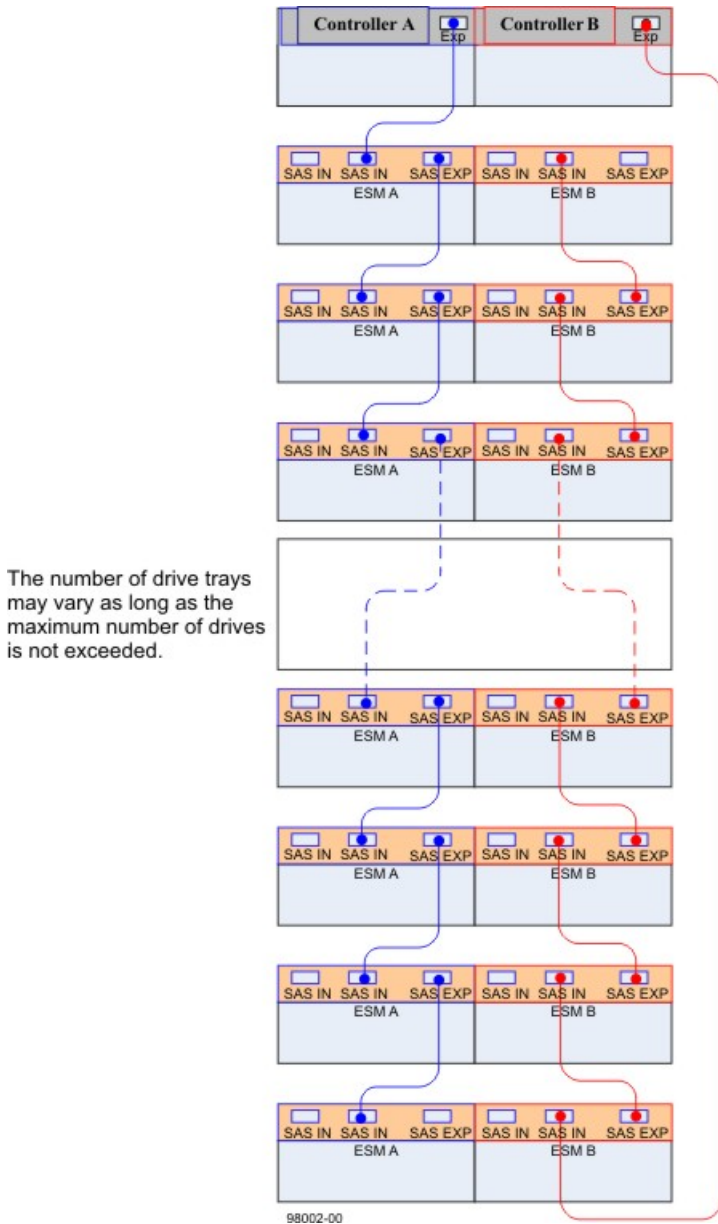

Drive Cabling Topologies for the CE2600-60 Controller-Drive Tray

This section provides examples of drive cabling topologies for the CE2600-60 controller-drive tray. The CE2600-60 controller-drive tray can be cabled only to DE6600 drive trays. The total number of drives in the storage array, including the drives in the controller-drive tray and those in the drive trays, must not exceed 192.

NOTE Simplex systems do not provide redundant connections to drive trays. If a connection or an environmental services monitor (ESM) fails, all drive trays that connect to the controller-drive tray indirectly through the failed connection or drive tray will become inaccessible.

Drive Cabling Topologies for the CE2600-60 Controller-Drive Tray With DE6600 Drive Trays

Depending on the number of drive trays that you need to connect, see the applicable figure for a cabling topology. Each example shows a duplex controller-drive tray configuration with redundant paths to the drive trays. For a simplex controller-drive tray configuration, use the cabling topology shown for controller A in the applicable figure.



WARNING (W15) Risk of bodily injury – An empty tray weighs approximately 56.7 kg (125 lb). Three persons are required to safely move an empty tray. If the tray is populated with components, a mechanized lift is required to safely move the tray.



NOTE Install trays beginning from the bottom of the cabinet so that the cabinet does not become top-heavy. A top-heavy cabinet has a greater risk of falling over.

The following figures show the SAS ports on a DE6600 drive tray. You may connect either of the SAS ports labeled SAS 1 and SAS 2 to the SAS expansion port on another drive tray or on a controller-drive tray. Do not make connections to both the SAS 1 port and the SAS 2 port on the same ESM.

SAS Ports on a DE6600 Drive Tray

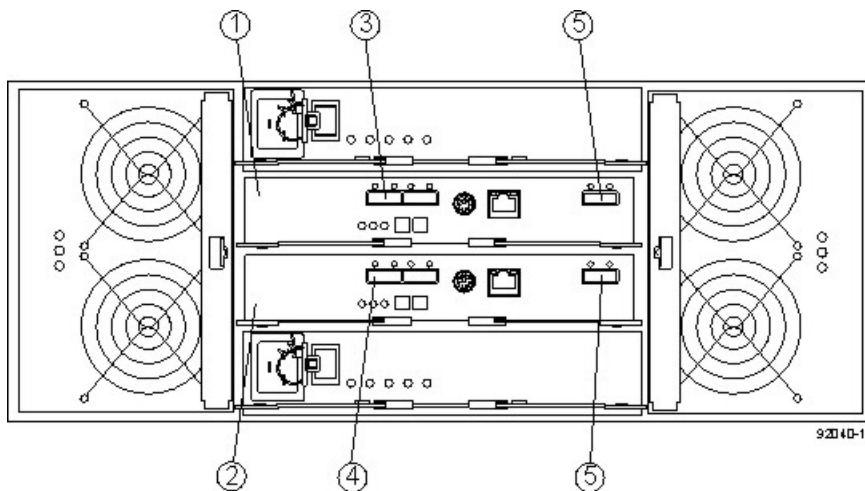

1. ESM A
2. ESM B
3. SAS In Port
4. SAS In Port
5. SAS Expansion Ports

One CE2600-60 Controller-Drive Tray and One Drive Tray

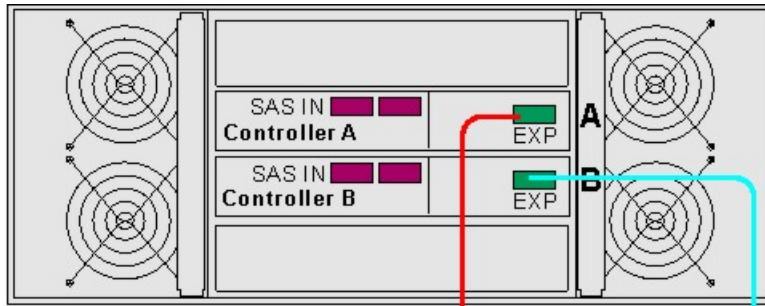

One CE2600-60 Controller-Drive Tray and Two Drive Trays

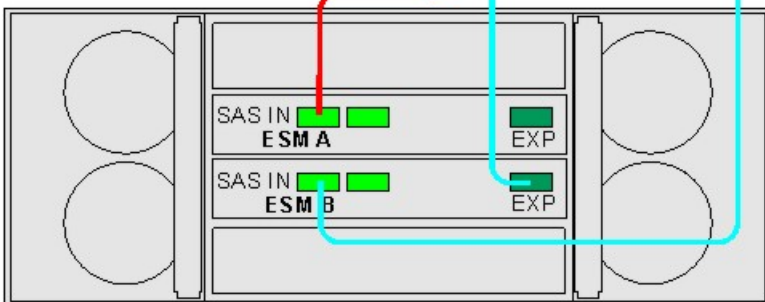
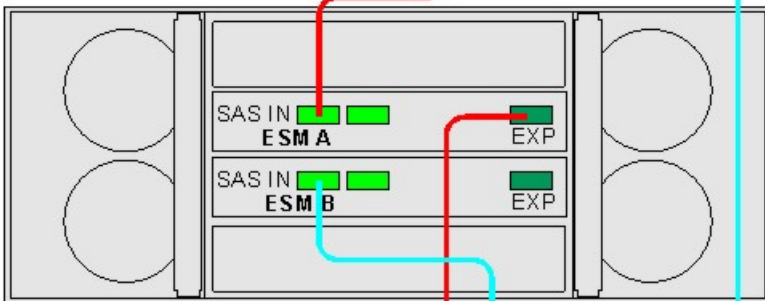
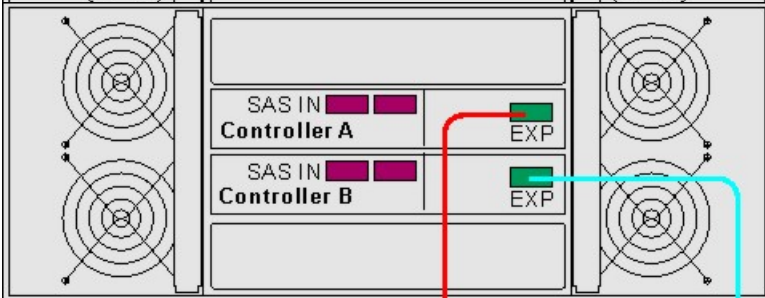
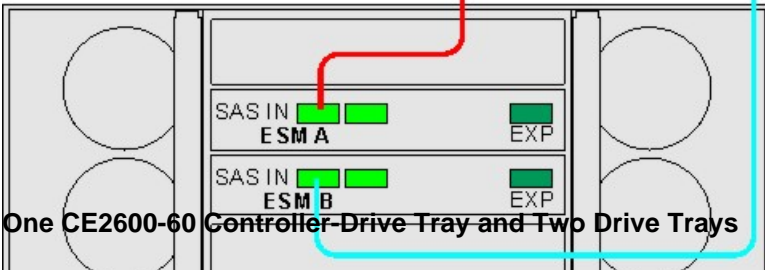

92031-06

Ethernet Cabling

This chapter provides examples of how to connect your storage array to an Ethernet network for out-of-band storage array management. If you plan to use in-band storage array management, Ethernet cabling might not be necessary for management connections.

For illustrations showing the Ethernet port locations on the specific controller tray model or controller-drive tray model that you are installing, see the topics under [Component Locations](#).

⚠ ATTENTION Possible loss of data access – If you use out-of-band management, connect the Ethernet ports on the controller tray or the controller-drive tray to a private network segment behind a firewall. If the Ethernet connection is not protected by a firewall, your storage array might be at risk of being accessed from outside of your network.

Direct Out-of-Band Ethernet Topology

The following figure shows storage array management connections from the controller tray or controller-drive tray to the Ethernet. In this topology, you must install a network interface card (NIC) in the storage management station in which the client software resides. For dual controllers, you must install two NICs in the storage management station.

📌 NOTE For more information about NICs, see [Network Interface Cards](#).

Network Out-of-Band Ethernet Topology

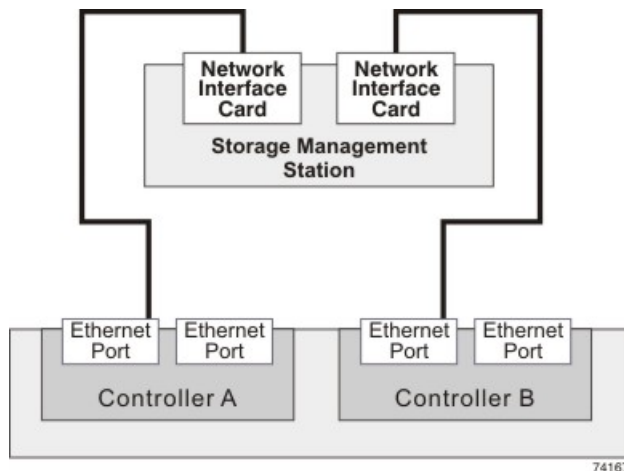

📌 NOTE In limited situations where the storage management station is connected directly to the controller tray or the controller-drive tray, you must use an Ethernet crossover cable to connect the storage management station to the Ethernet port. An Ethernet crossover cable is a special cable that reverses the pin contacts between the two ends of the cable.

Fabric Out-of-Band Ethernet Topology

The following figure shows two storage array management connections from the controller tray or the controller-drive tray to two ports on an Ethernet switch. In this topology, you must install a NIC in the storage management station where the client software resides. You must use Ethernet cables for all storage array management connections.

Fabric Redundant Out-of-Band Ethernet Topology

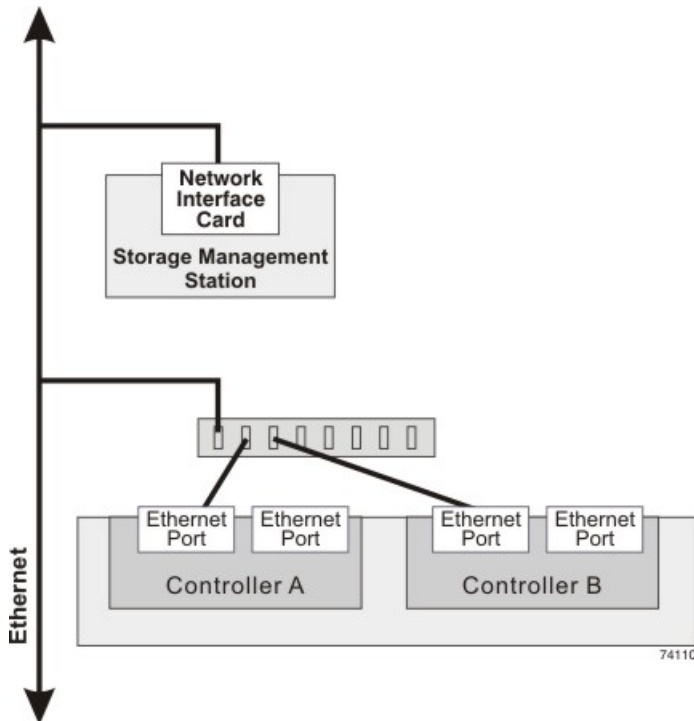

For more information, see [In-Band Management and Out-of-Band Management](#)



NOTE If you have two available Ethernet ports on each controller, reserve one port on each controller for access to the storage array by your Customer and Technical Support representative.

Component Locations

This chapter provides shows the rear of each controller tray, controller-drive tray, and drive tray. The figures identify the locations of controllers, environmental services monitors (ESMs), host ports, drive ports, and Ethernet ports. The figures also show port identifiers.

Use the figures in the following topics to make sure that you have correctly identified the cable connection for host cabling, drive cabling and Ethernet cabling.

Port Locations on the CE7922 Controller Tray and the CE7900 Controller Tray

The CE7922 controller tray and the CE7900 controller tray have host channels that you can attach to the hosts, and drive channels that you can attach to the drive trays. The examples in this section show the CE7900 controller tray. The port locations are the same for the CE7922 controller tray.

- Each of the two controllers in the CE7900 controller tray might have two host cards with four host ports on each card. This configuration is shown in the following figure. Some CE7900 controller trays might have controllers with only one host card each.
- Controller A is inverted from controller B, which means that its host channels are upside-down.

Host Channels on the CE7922 Controller Tray and the CE7900 Controller Tray – Rear View

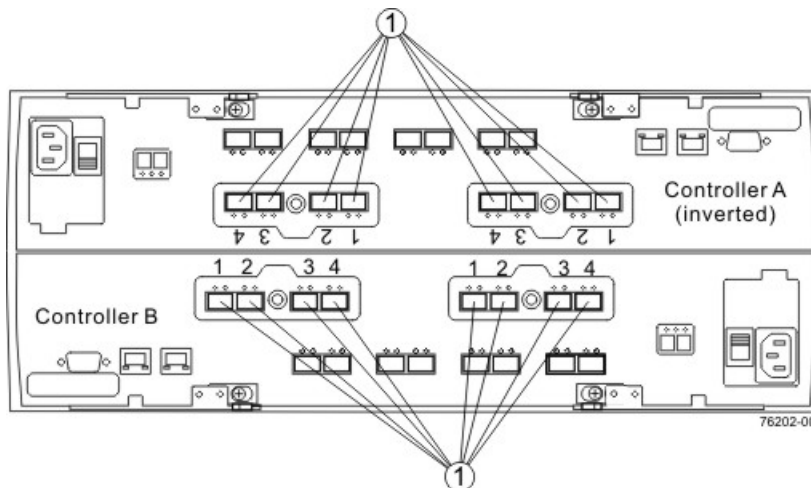

1. Host Channel Ports

- Each controller in the CE7922 controller tray and the CE7900 controller tray has four drive channels, and each drive channel has two ports, so each controller has eight drive ports.
- Controller A is inverted from controller B, which means that its drive channels are upside-down.

Drive Channel Ports on the CE7922 Controller Tray and the CE7900 Controller Tray – Rear View

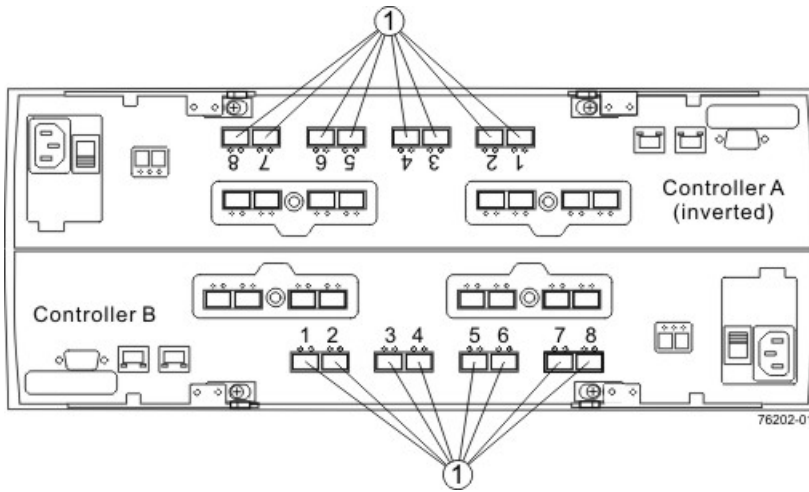

1. Drive Channel Ports

Component Locations on the CE6998 Controller Tray

Component Locations on the CE6998 Controller Tray – Rear View

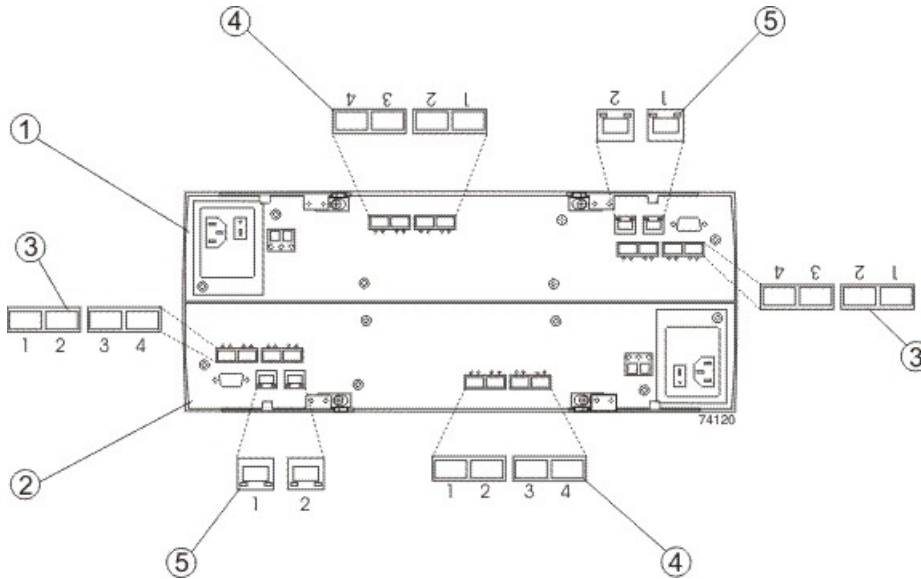

- 1. Controller A (Inverted)
- 2. Controller B
- 3. Host Ports
- 4. Drive Ports
- 5. Ethernet Ports

NOTE Host port 4 on each controller of the CE6998 controller tray is reserved for the Remote Volume Mirroring premium feature. If you are not using the Remote Volume Mirroring premium feature, these host ports are available for host connections.

Drive Ports and Drive Channels on the CE6998 Controller Tray

| Drive Channel Number | Controller | Drive Port Numbers |
|----------------------|------------|--------------------|
| 1 | A | 4 and 3 |
| 2 | A | 2 and 1 |
| 3 | B | 1 and 2 |
| 4 | B | 3 and 4 |



NOTE When you cable the CE6998 controller tray, it is important to note that drive channel 1 and drive channel 3 are a redundant pair, and drive channel 2 and drive channel 4 are a redundant pair. In other words, if a failure occurred in drive channel 1, drive channel 3 would allow communication with the drives. If a failure occurred in drive channel 2, drive channel 4 would allow communication with the drives.

Component Locations on the CE5400 Controller-Drive Trays

The CE5400 controller-drive trays include three models: the CE5400-60, the CE5400-24, and the CE5400-12. Keep these points in mind when you compare the figures in this section to your hardware.

- The top of the controller-drive tray is the side with the labels.
- The configuration of the host ports depends on which host interface card configuration is installed.
- The figures in this section show the AC power option.

CE5400-60 Controller-Drive Tray – Front View with Bezel Removed

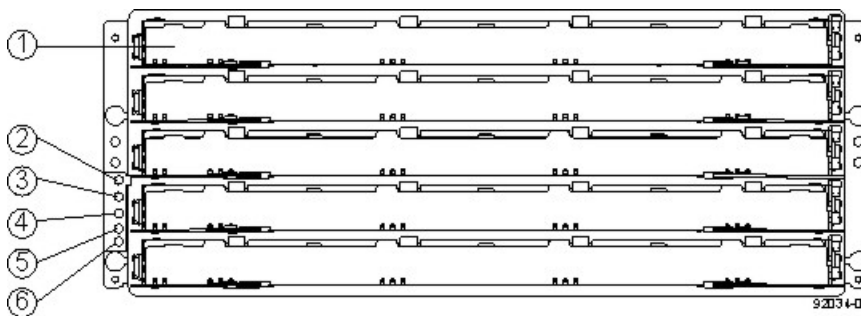

1. Drive Drawer
2. Locate LED
3. Service Action Required LED
4. Over-Temperature LED
5. Power LED
6. Standby Power LED

CE5400-60 Controller-Drive Tray – Rear View

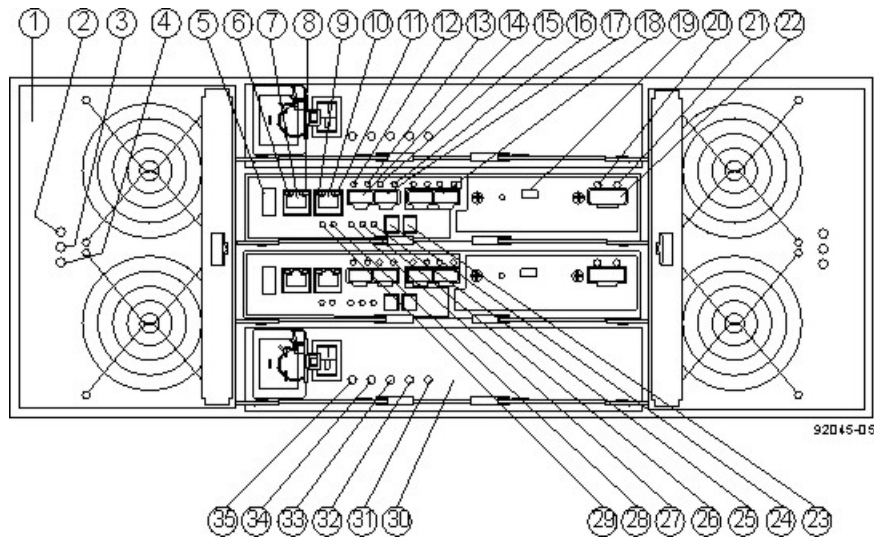

1. Fan Canister
2. Fan Power LED
3. Fan Service Action Required LED
4. Fan Service Action Allowed LED
5. USB Connector
6. Ethernet Link 1 Active LED
7. Ethernet Connector 1
8. Ethernet Link 1 Rate LED
9. Ethernet Link 2 Active LED
10. Ethernet Connector 2
11. Ethernet Link 2 Rate LED
12. Fibre Channel Link 1 Up LED
13. Fibre Channel Link 1 Active LED
14. Fibre Channel Connector 1
15. Fibre Channel Link 2 Up LED
16. Fibre Channel Link 2 Active LED
17. Fibre Channel Connector 2
18. Fibre Channel Connector 4
19. Mini USB Connector
20. Expansion Fault LED
21. Expansion Active LED
22. Expansion SFF-8088 Port Connector
23. Second Seven-Segment Display Field
24. First Seven-Segment Display Field
25. Cache Active LED
26. Controller A Service Action Required LED
27. Controller A Service Action Allowed LED
28. Battery Charging LED
29. Battery Service Action Required LED
30. Power Canister
31. Power Canister AC Power LED
32. Power Canister Service Required Allowed LED
33. Power Canister Service Action Allowed LED
34. Power Canister DC Power LED
35. Power Canister Standby Power LED

CE5400-24 Controller-Drive Tray – Front View

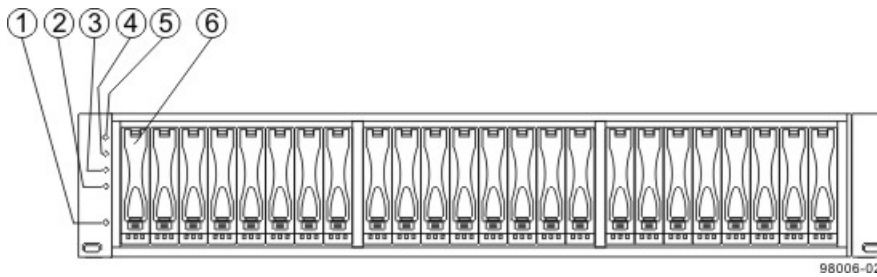

1. Standby Power LED
2. Power LED
3. Over-Temperature LED
4. Service Action Required LED
5. Locate LED
6. Drive Canister

CE5400-12 Controller-Drive Tray – Front View

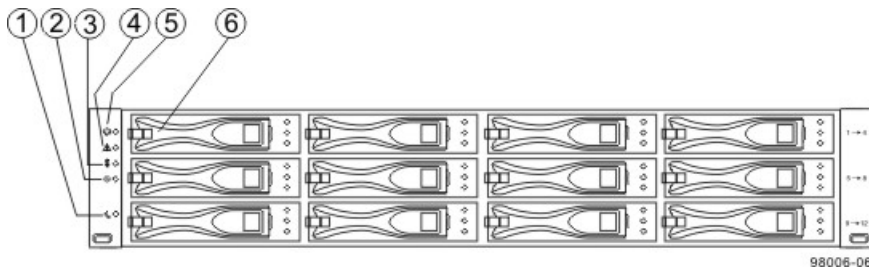

1. Standby Power LED
2. Power LED
3. Over-Temperature LED
4. Service Action Required LED
5. Locate LED
6. Drive Canister

CE5400-24 Controller-Drive Tray and CE5400-12 Controller-Drive Tray– Rear View

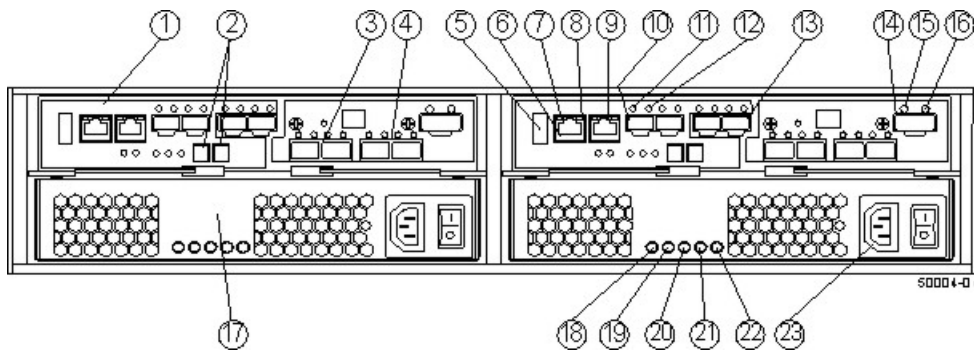

1. Controller A Canister
2. Seven-Segment Display
3. Host Interface Card Connector 1
4. Host Interface Card Connector 2
5. Serial Connector
6. Ethernet Connector 1
7. Ethernet Link Active LED
8. Ethernet Link Rate LED
9. Ethernet Connector 2
10. Host SFF-8088 Connector 2
11. Host Link 2 Fault LED
12. Host Link 2 Active LED
13. Base Host SFF-8088 Connector 1
14. ESM Expansion Fault LED
15. ESM Expansion Active LED
16. Expansion SFF-8088 Port Connector
17. Power-Fan Canister
18. Standby Power LED
19. Power-Fan DC Power LED
20. Power-Fan Service Action Allowed LED
21. Power-Fan Service Action Required LED
22. Power-Fan AC Power LED
23. AC Power Connector

CE5400 Right-Rear Subplate with No Host Interface Card

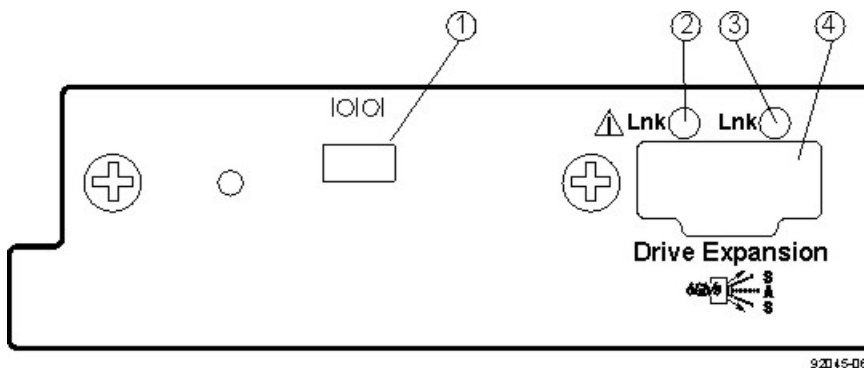

1. Mini USB Connector
2. ESM Expansion Fault LED
3. ESM Expansion Active LED
4. Expansion SFF-8088 Port Connector

CE5400 Right-Rear Subplate with an Fibre Channel Host Interface Card

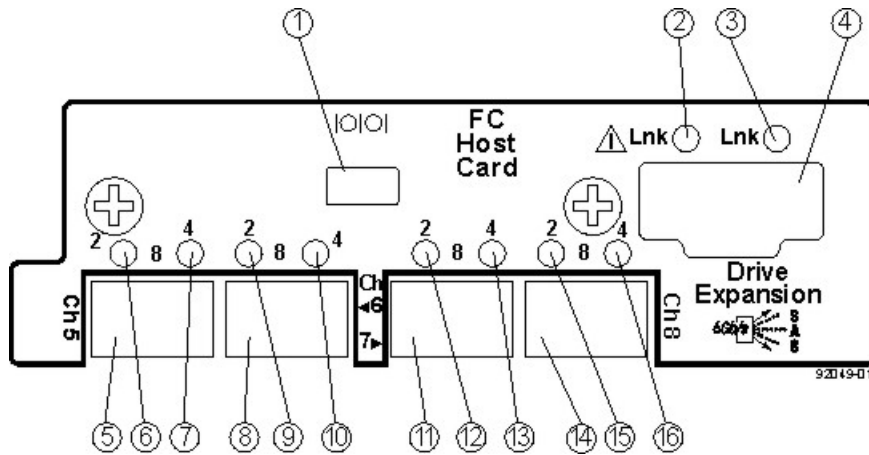

1. Mini USB Connector
2. SAS Expansion Fault LED
3. SAS Expansion Active LED
4. SAS Expansion SFF-8088 Port Connector
5. FC Host Interface Card Connector 5
6. Host Interface Card Link 5 LED 0
7. Host Interface Card Link 5 LED 1
8. FC Host Interface Card Connector 6
9. Host Interface Card Link 6 LED 0
10. Host Interface Card Link 6 LED 1
11. FC Host Interface Card Connector 7
12. Host Interface Card Link 7 LED 0
13. Host Interface Card Link 7 LED 1
14. FC Host Interface Card Connector 8
15. Host Interface Card Link 8 LED 0
16. Host Interface Card Link 8 LED 1

CE5400 Right-Rear Subplate with an InfiniBand Host Interface Card

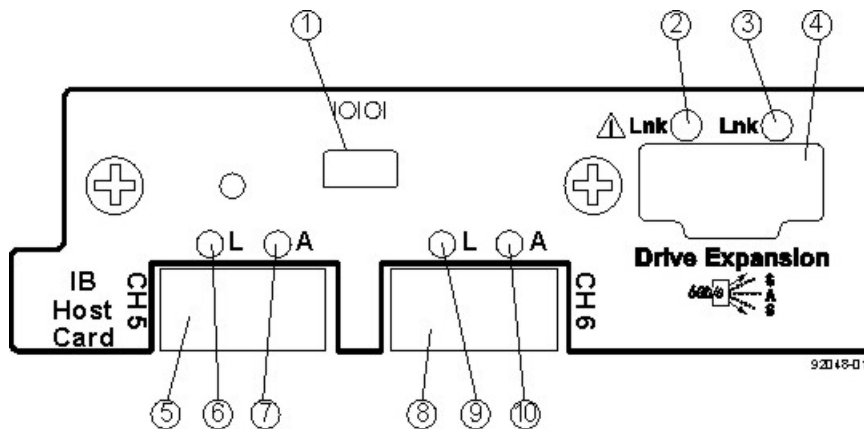

1. Mini USB Connector
2. SAS Expansion Fault LED
3. SAS Expansion Active LED
4. SAS Expansion SFF-8088 Port Connector
5. IB Host Interface Card Connector 1
6. IB Host Interface Card Physical Link 1 LED (Green)
7. IB Host Interface Card Logical Link 1 LED (Amber)
8. IB Host Interface Card Connector 2
9. IB Host Interface Card Physical Link 2 LED (Green)
10. IB Host Interface Card Logical Link 2 LED (Amber)

Component Locations on the CE4900 Controller-Drive Tray

- The top controller, controller A, is inverted from the bottom controller, controller B.
- The top of the controller-drive tray is the side with labels.
- The configuration of the host ports might appear different on your system depending on which host interface card configuration is installed.

CE4900 Controller-Drive Tray – Front View and Rear View

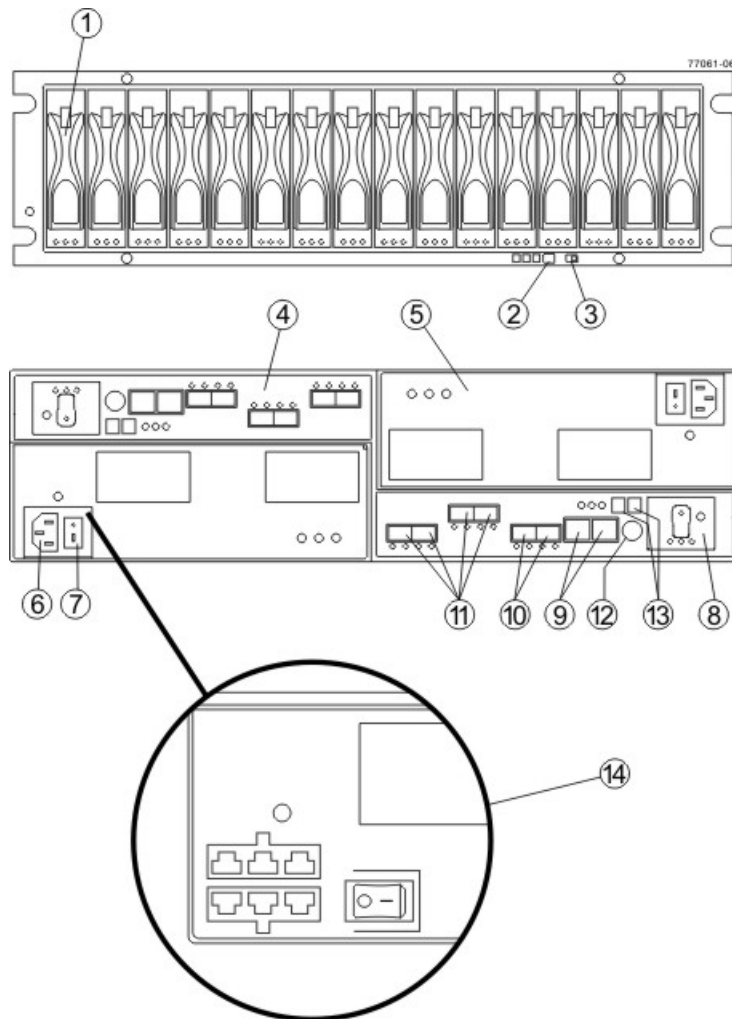

1. Drive Canister
2. Alarm Mute Switch
3. Link Rate Switch
4. Controller A (Inverted)
5. Power-Fan Canister
6. AC Power Connector
7. AC Power Switch
8. Battery Canister
9. Ethernet Ports
10. Drive Channels
11. Host Channels
12. Serial Port
13. Seven-Segment Display
14. Optional DC Power Connector and DC Power Switch

Component Locations on the CDE3994 Controller-Drive Tray and the CDE3992 Controller-Drive Tray

The following figure shows the AC power option.

Component Locations on the CDE3994 Controller-Drive Tray and the CDE3992 Controller-Drive Tray – Rear View

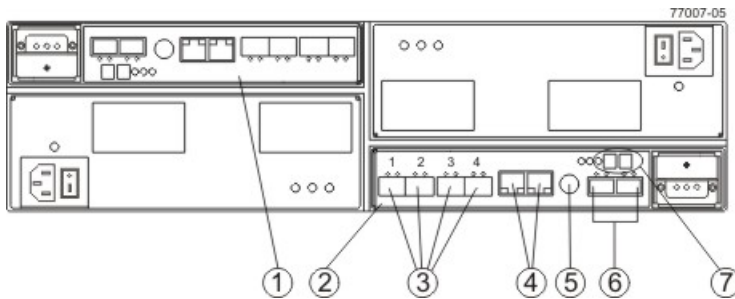

1. Controller A (Inverted)
2. Controller B
3. Host Ports (2 Ports for the CDE3992 Controller-Drive Tray or 4 Ports for the CDE3994 Controller-Drive Tray)
4. Ethernet Ports
5. Serial Port
6. Dual-Ported Drive Ports
7. Seven-Segment Display

Drive Ports and Drive Channels on the CDE3994 Controller-Drive Tray and the CDE3992 Controller-Drive Tray

| Drive Channel Number | Controller | Drive Port Identifier |
|----------------------|------------|-----------------------|
| 1 | A | 2 and 1 |
| 2 | B | 1 and 2 |

Component Locations on the CE2600 Controller-Drive Tray

The CE2600 controller-drive tray is available in two different drive configurations: one with up to twelve 3.5-in. drives and another with up to twenty-four 2.5-in. drives. With either drive configuration, the controller-drive tray is available in two different controller configurations: simplex and duplex.

Keep these points in mind when you compare the figures in this section to your hardware.

- The top of the controller-drive tray is the side with the labels.
- The configuration of the host ports depends on which host interface card configuration is installed.
- The figures in this section show the AC power option.



NOTE On the CE2600 controller-drive tray, each controller has a pair of levers with handles for removing the controller from the controller-drive tray. If a controller has a HIC installed, one of these handles on the controller is located next to a host port on the HIC. The close spacing between the handle and the host port might make it difficult to remove a cable that is attached to the host port. If this problem occurs, use a flat-blade screwdriver to compress the release on the cable connector.

CE2600 Controller-Drive Tray with 12 Drives – Front View

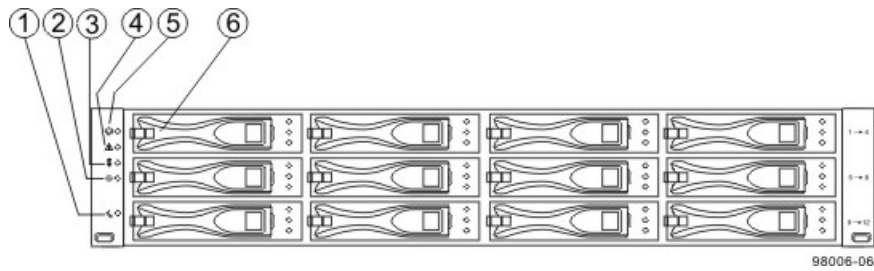

1. Standby Power LED
2. Power LED
3. Over-Temperature LED
4. Service Action Required LED
5. Locate LED
6. Drive Canister

CE2600 Controller-Drive Tray with 24 Drives – Front View

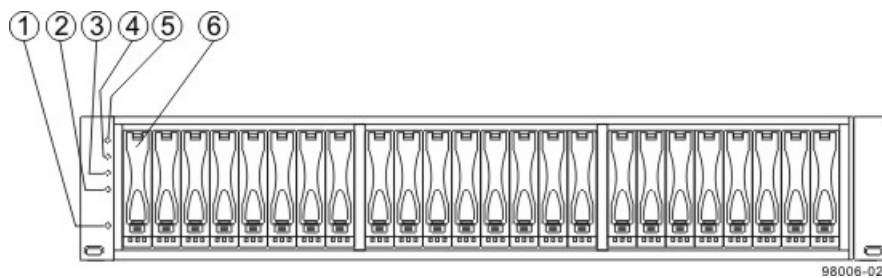

1. Standby Power LED
2. Power LED
3. Over-Temperature LED
4. Service Action Required LED
5. Locate LED
6. Drive Canister

CE2600 Controller-Drive Tray Duplex Configuration – Rear View

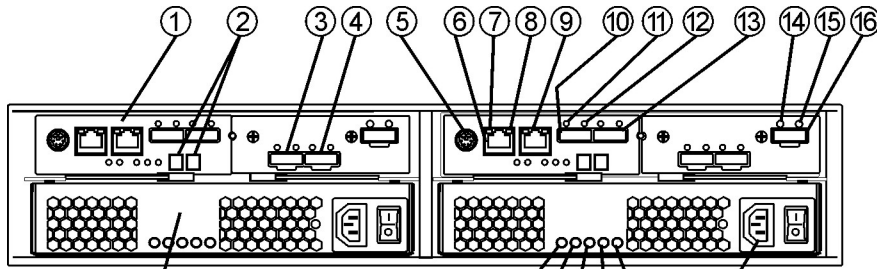

98006-03

- 1. Controller A Canister
- 2. Seven-Segment Display
- 3. Host Interface Card Connector 1
- 4. Host Interface Card Connector 2
- 5. Serial Connector
- 6. Ethernet Connector 1
- 7. Ethernet Link Active LED
- 8. Ethernet Link Rate LED
- 9. Ethernet Connector 2
- 10. Host SFF-8088 Connector 2
- 11. Host Link 2 Fault LED
- 12. Host Link 2 Active LED
- 13. Base Host SFF-8088 Connector 1
- 14. ESM Expansion Fault LED
- 15. ESM Expansion Active LED
- 16. Expansion SFF-8088 Port Connector
- 17. Power-Fan Canister
- 18. Standby Power LED
- 19. Power-Fan DC Power LED
- 20. Power-Fan Service Action Allowed LED
- 21. Power-Fan Service Action Required LED
- 22. Power-Fan AC Power LED
- 23. AC Power Connector

CE2600 Right-Rear Subplate with No Host Interface Card



98019-04

- 1. ESM Expansion Fault LED
- 2. ESM Expansion Active LED
- 3. Expansion SFF-8088 Port Connector

CE2600 Right-Rear Subplate with a SAS Host Interface Card

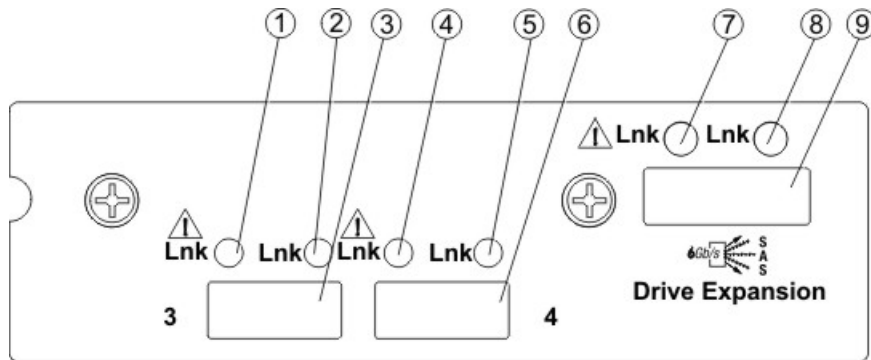

98019-03

1. Host Interface Card Link 3 Up LED
2. Host Interface Card Link 3 Active LED
3. SFF-8088 Host Interface Card Connector 3
4. Host Interface Card Link 4 Up LED
5. Host Interface Card Link 4 Active LED
6. SFF-8088 Host Interface Card Connector 4
7. ESM Expansion Fault LED
8. ESM Expansion Active LED
9. Expansion SFF-8088 Port Connector

CE2600 Right-Rear Subplate with an FC Host Interface Card

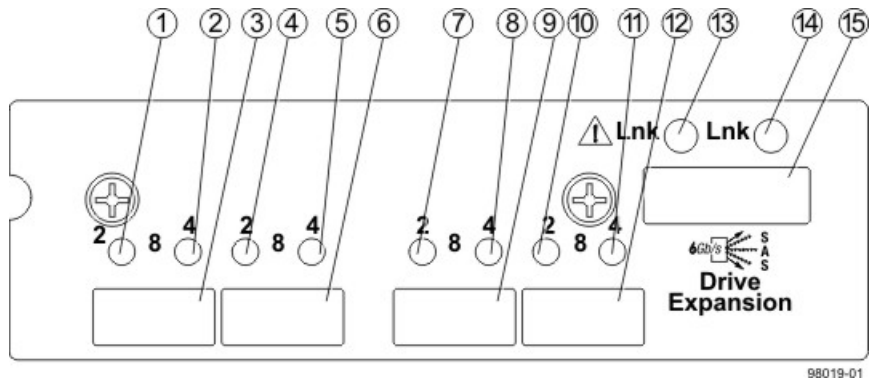

98019-01

1. Host Interface Card Link 3 Up LED
2. Host Interface Card Link 3 Active LED
3. FC Host Interface Card Connector 3
4. Host Interface Card Link 4 Up LED
5. Host Interface Card Link 4 Active LED
6. FC Host Interface Card Connector 4
7. Host Interface Card Link 5 Up LED
8. Host Interface Card Link 5 Active LED
9. FC Host Interface Card Connector 5
10. Host Interface Card Link 6 Up LED
11. Host Interface Card Link 6 Active LED
12. FC Host Interface Card Connector 6
13. ESM Expansion Fault LED
14. ESM Expansion Active LED
15. Expansion SFF-8088 Port Connector

CE2600 Right-Rear Subplate with an iSCSI Host Interface Card

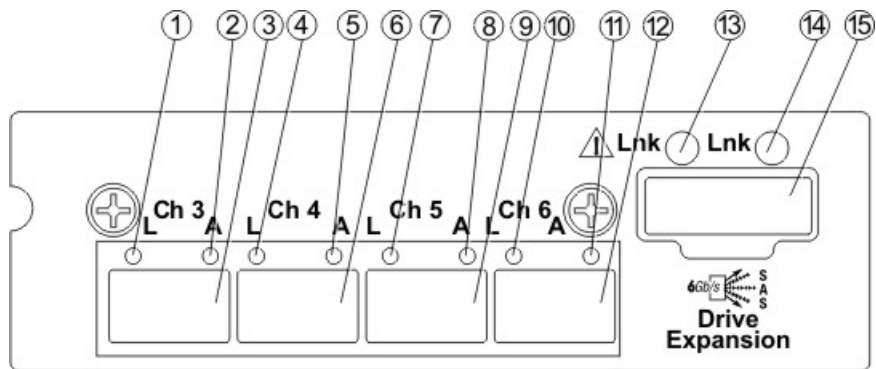

98019-02

1. Host Interface Card Link 3 Up LED
2. Host Interface Card Link 3 Active LED
3. iSCSI Host Interface Card Connector 3
4. Host Interface Card Link 4 Up LED
5. Host Interface Card Link 4 Active LED
6. iSCSI Host Interface Card Connector 4
7. Host Interface Card Link 5 Up LED
8. Host Interface Card Link 5 Active LED
9. iSCSI Host Interface Card Connector 5
10. Host Interface Card Link 6 Up LED
11. Host Interface Card Link 6 Active LED
12. iSCSI Host Interface Card Connector 6
13. ESM Expansion Fault LED
14. ESM Expansion Active LED
15. Expansion SFF-8088 Port Connector

CE2600 Controller-Drive Tray Simplex Configuration – Rear View

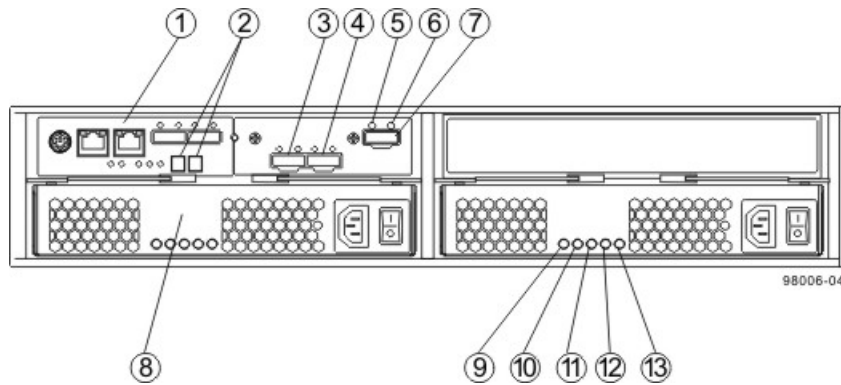

1. Controller A Canister
2. Seven-Segment Display
3. Host Interface Card Connector 1
4. Host Interface Card Connector 2
5. ESM Expansion Fault LED
6. ESM Expansion Active LED
7. Expansion Port SFF-8088 Connector
8. Power-Fan A Canister
9. Standby Power LED
10. Power-Fan DC Power LED
11. Power-Fan Service Action Allowed LED
12. Power-Fan Service Action Required LED
13. Power-Fan AC Power LED

Component Locations on the CE2600-60 Controller-Drive Tray

The CE2600-60 controller-drive tray is available in two different controller configurations: simplex and duplex.

Keep these points in mind when you compare the figures in this section to your hardware.

- The top of the controller-drive tray is the side with the labels.
- The configuration of the host ports depends on which host interface card configuration is installed.
- The figures in this section show the AC power option.

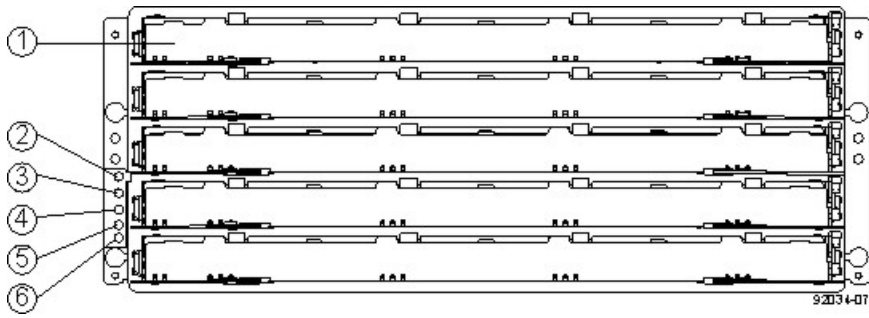

NOTE On the CE2600-60 controller-drive tray, each controller has a pair of levers with handles for removing the controller from the controller-drive tray. If a controller has a HIC installed, one of these handles on the controller is located next to a host port on the HIC. The close spacing between the handle and the host port might make it difficult to remove a cable that is attached to the host port. If this problem occurs, use a flat-blade screwdriver to compress the release on the cable connector.

CE2600-60 Controller-Drive Tray – Front View

1. Drive Drawer
2. Standby Power LED
3. Power LED
4. Over-Temperature LED
5. Service Action Required LED
6. Locate LED

CE2600-60 Controller-Drive Tray – Rear View

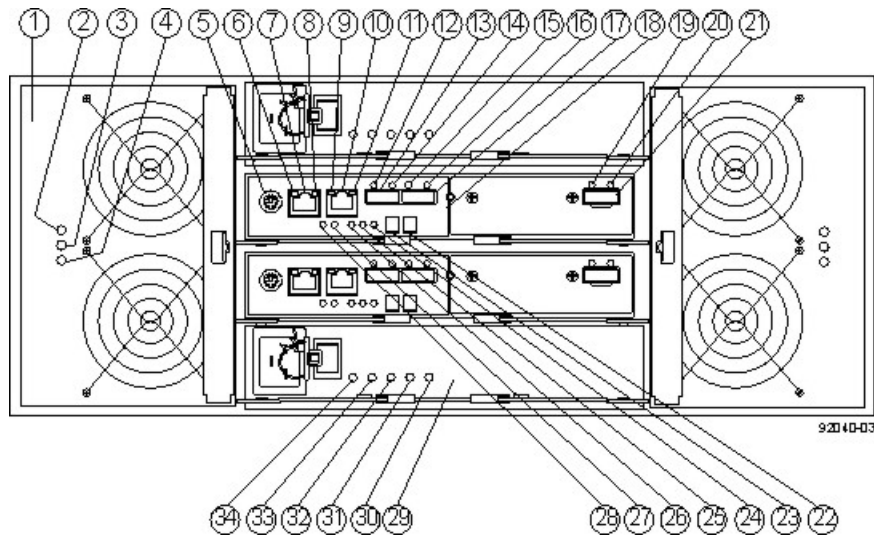

1. Fan Canister
2. Fan Power LED
3. Fan Service Action Required LED
4. Fan Service Action Allowed LED
5. Serial Connector
6. Ethernet Link 1 Active LED
7. Ethernet Connector 1
8. Ethernet Link 1 Rate LED
9. Ethernet Link 2 Active LED
10. Ethernet Connector 2
11. Ethernet Link 2 Rate LED
12. Host Link 2 Fault LED
13. Base Host SFF-8088 Connector 2
14. Host Link 2 Active LED
15. Host Link 1 Fault LED
16. Host Link 1 Active LED
17. Base Host SFF-8088 Connector 1
18. Controller A Canister
19. ESM Expansion Fault LED
20. ESM Expansion Active LED
21. Expansion SFF-8088 Port Connector
22. Second Seven-Segment Display
23. First Seven-Segment Display
24. Cache Active LED
25. Controller A Service Action Required LED
26. Controller A Service Action Allowed LED
27. Battery Service Action Required LED
28. Battery Charging LED
29. Power Canister
30. Power AC Power LED
31. Power Service Action Required LED
32. Power Service Action Allowed LED
33. Power DC Power LED
34. Power Standby Power LED

CE2600-60 Right-Rear Subplate with No Host Interface Card



98019-04

1. ESM Expansion Fault LED
2. ESM Expansion Active LED
3. Expansion SFF-8088 Port Connector

CE2600-60 Right-Rear Subplate with a SAS Host Interface Card

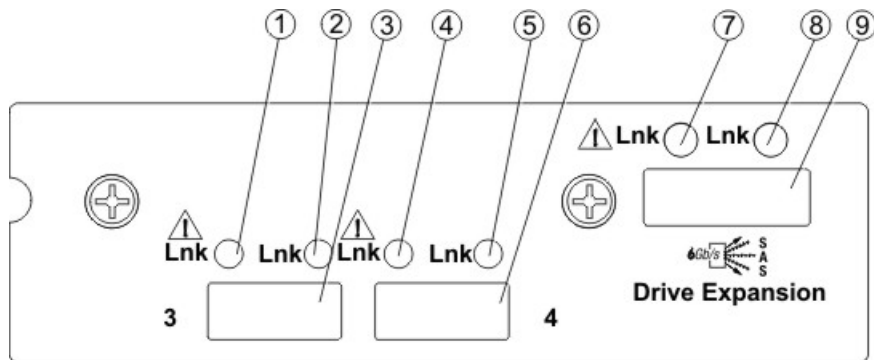

98019-03

1. Host Interface Card Link 3 Up LED
2. Host Interface Card Link 3 Active LED
3. SFF-8088 Host Interface Card Connector 3
4. Host Interface Card Link 4 Up LED
5. Host Interface Card Link 4 Active LED
6. SFF-8088 Host Interface Card Connector 4
7. ESM Expansion Fault LED
8. ESM Expansion Active LED
9. Expansion SFF-8088 Port Connector

Component Locations on the DE6900 Drive Tray

DE6900 Drive Tray – Front View with the Bezel

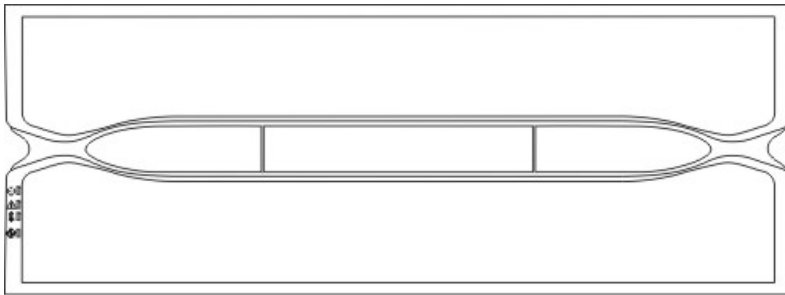

92013-00

DE6900 Drive Tray – Front View with the Bezel Removed

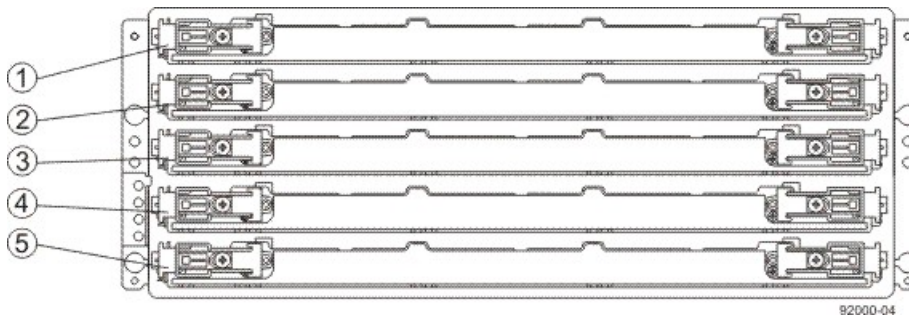

92000-04

1. Drive Drawer 1
2. Drive Drawer 2
3. Drive Drawer 3
4. Drive Drawer 4
5. Drive Drawer 5

DE6900 Drive Tray – Rear View

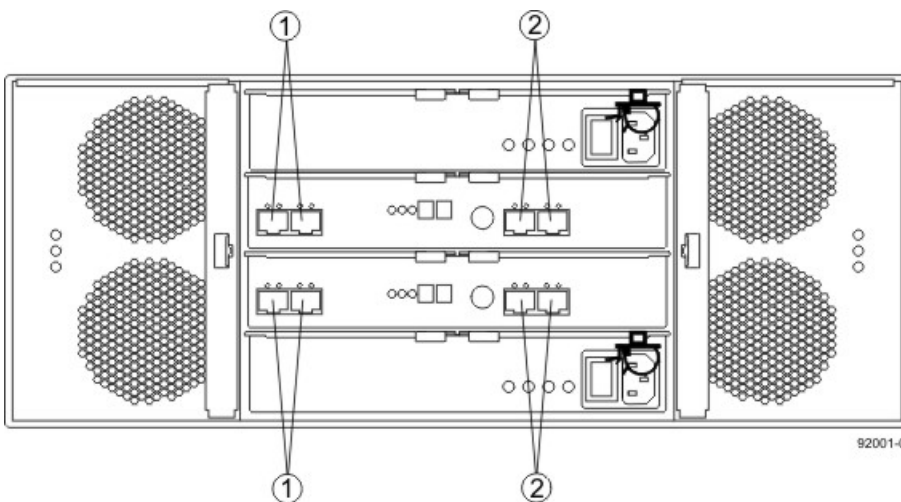

92001-03

1. Standard Expansion Connectors
2. Drive-Side Trunking Expansion Connectors

Component Locations on the DE6600 Drive Tray

DE6600 Drive Tray – Front View with the Bezel

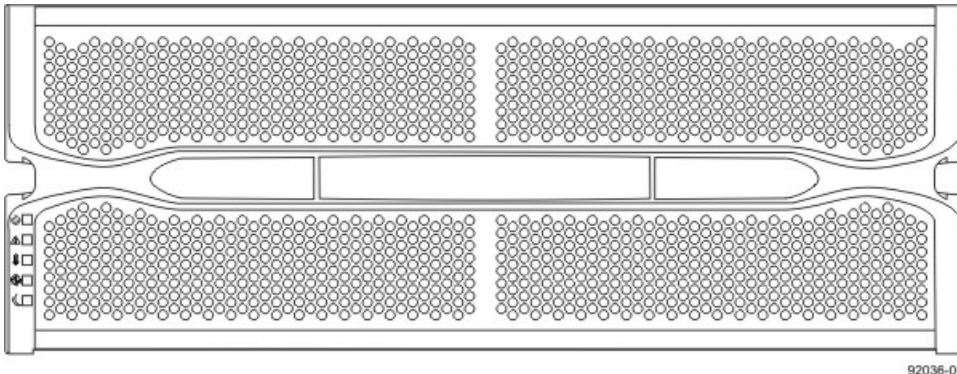

92036-01

DE6600 Drive Tray – Front View with the Bezel Removed

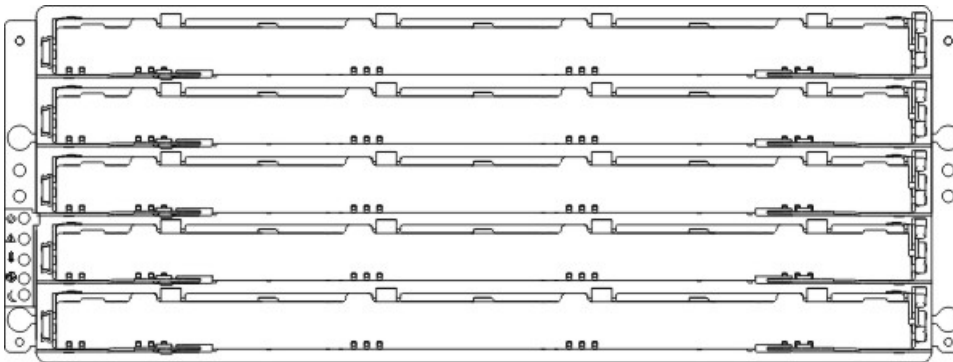

92034-04

DE6600 Drive Tray – Rear View

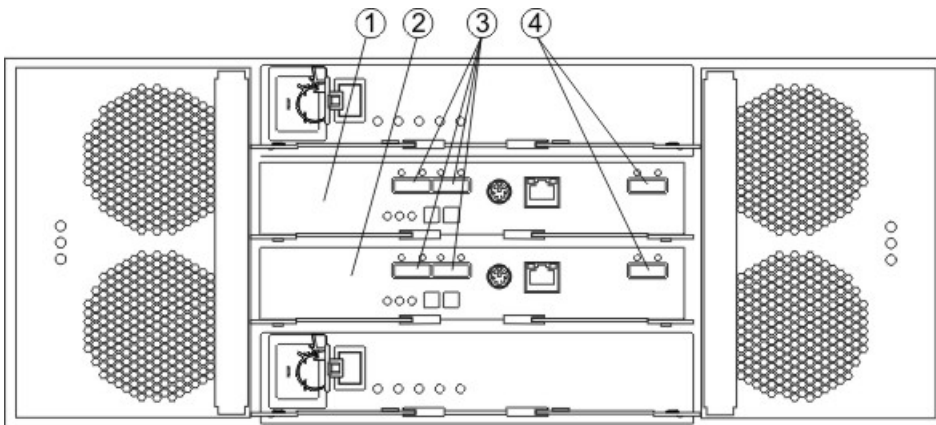

92033-01

1. ESM A
2. ESM B
3. SAS In Connectors
4. Expansion Connectors

Component Locations on the FC4600 Drive Tray

Component Locations on the FC4600 Drive Tray – Rear View

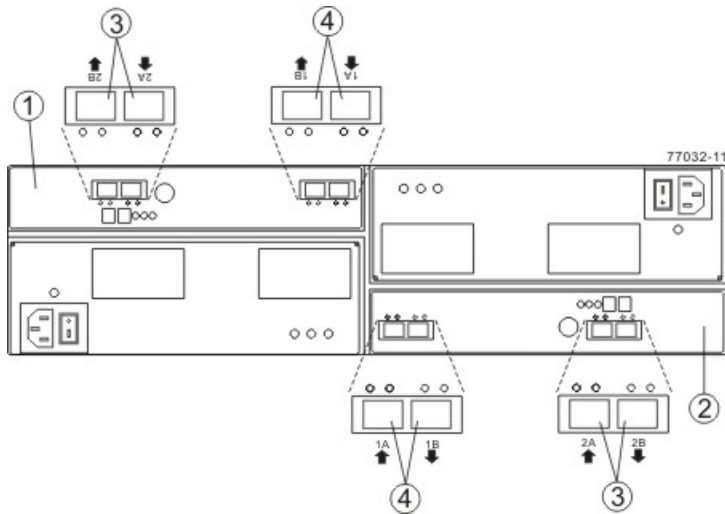

1. Left ESM
2. Right ESM
3. Secondary SFP Ports
4. Primary SFP Ports

The ESM on the FC4600 drive tray has four SFP ports. The two primary ports are active. The secondary ports are reserved for future use. If SFP transceivers are placed in the secondary ports, the SFP Port LEDs blink, as a reminder that these ports are not functioning.

Component Locations on the AT2655 Drive Tray

Component Locations on the AT2655 Drive Tray – Rear View

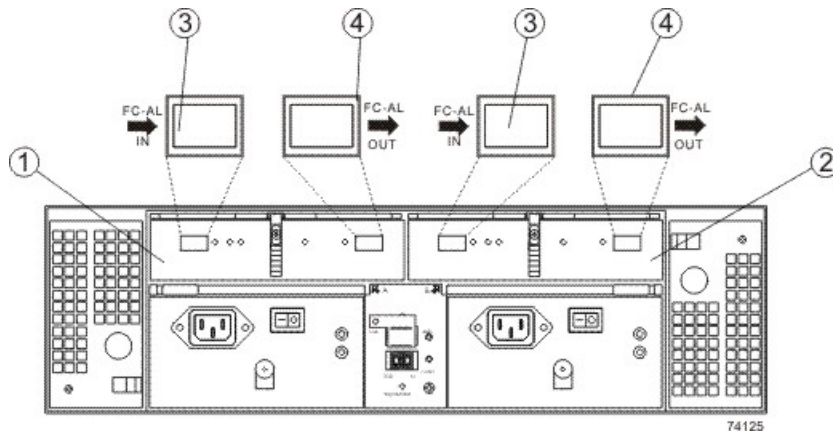

1. Left ESM
2. Right ESM
3. In Ports
4. Out Ports

Component Locations on the FC2610 Drive Tray

Component Locations on the FC2610 Drive Tray – Rear View

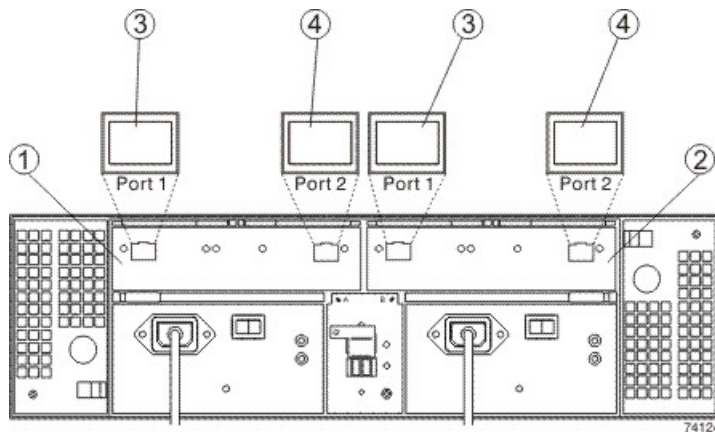

1. Left ESM
2. Right ESM
3. In Ports
4. Out Ports

Component Locations on the FC2600 Drive Tray

Component Locations on the FC2600 Drive Tray – Rear View

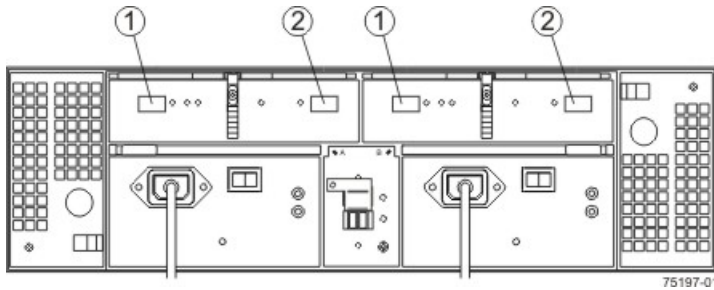

- 1. In Ports
- 2. Out Ports

Component Locations on the DE1600 Drive Tray and the DE5600 Drive Tray

The DE1600 drive tray can have two to twelve 3.5-in. drives. The DE5600 drive tray can have two to twenty-four 2.5-in. drives. The component locations on the rear of these drive trays are the same. The following figures show the AC power option.

DE1600 Drive Tray – Front View

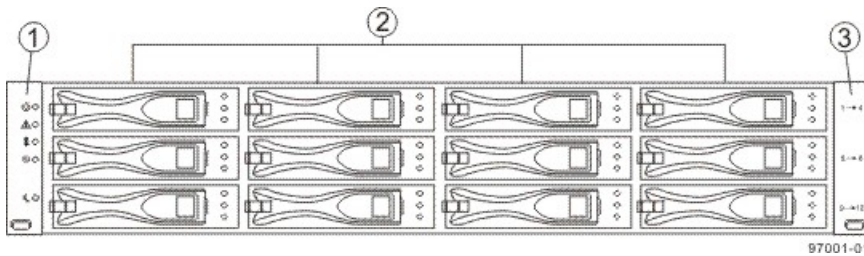

- 1. Left End Cap (Has the Drive Tray LEDs)
- 2. Drives
- 3. Right End Cap

DE5600 Drive Tray – Front View

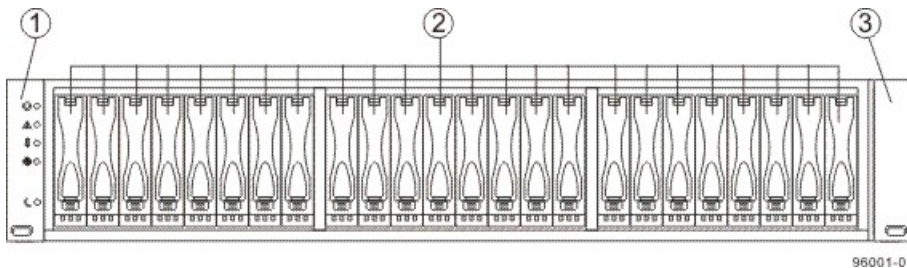

- 1. Left End Cap (Has the Drive Tray LEDs)
- 2. Drives
- 3. Right End Cap

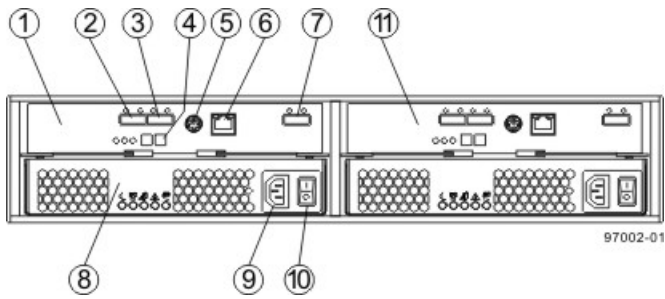
DE1600 Drive Tray or DE5600 Drive Tray – Rear View

1. ESM A Canister
2. Host Connector 1
3. Host Connector 2
4. Seven-Segment Display Indicators
5. Serial Connector
6. Ethernet Connector
7. Expansion Port SFF-8088 Connector
8. Power-Fan Canister
9. Power Connector
10. Power Switch
11. ESM B Canister

Adding a Drive Tray to an Existing System

This chapter provides information about adding a drive tray to an existing system.

Getting Ready

If you need to add another drive tray to an existing storage array, contact your Customer and Technical Support representative before proceeding. Your Customer and Technical Support representative might direct you to complete preparatory tasks before installing and cabling the new drive tray. Some of these tasks might include:

- Creating, saving, and printing a storage array profile for all of the storage arrays that will be affected by the upgrade
- Performing a complete backup of all of the drives in the storage array
- Making sure that the volume groups and associated volumes on the storage array have an Optimal status



ATTENTION Possible loss of data access – Contact your Customer and Technical Support representative if you plan to add a drive tray to an existing storage array under either of the following conditions: The power is not turned off to the controller tray or the controller-drive tray or data transfer continues to the storage array.

HotScale Technology

HotScale™ technology lets you configure, reconfigure, add, or relocate storage array capacity without interrupting user access to data.

Port bypass technology automatically opens ports and closes ports when drive trays are added to or removed from your storage array. Fibre Channel loops stay intact so that system integrity is maintained throughout the process of adding and reconfiguring your storage array.

For more information about using the HotScale technology, contact your Customer and Technical Support representative.

Adding Redundant Drive Channels

If you are working with a storage array that has redundant drive channels, it is easy to add drive trays. Make sure that you always maintain communication between a functioning controller and the existing drive trays by only interrupting the continuity of a single drive channel at any one point in time. This precaution avoids interruption of data availability.

Your Customer and Technical Support representative can provide assistance in maintaining access to data during the upgrade of your storage array.

Adding One Non-Redundant Drive Channel

If you are working with a storage array that has only one drive channel, add the drive tray to the end of the series of drive trays in the storage array. You do so while power is still applied to the other drive trays.



ATTENTION Risk of equipment damage – If your FC4600 drive tray, DE1600 drive tray, or DE5600 drive tray uses the optional DC power connection, a different procedure exists for turning on and turning off the power to a DC-powered drive tray. Refer to the topics under *Storage Array Installation* for the hardware you are installing or refer to the corresponding PDF document on the SANtricity ES Storage Manager Installation DVD.

1. Add the new drive tray to the end of the series of existing drive trays.
2. Install the additional cable.
3. Turn on the power to the new drive tray.

Hardware Installation for Remote Volume Mirroring

This appendix provides information about these topics:

- Site preparation
- Hardware requirements
- Cabling

Review this information and complete the steps before starting any hardware installation procedures. Refer to the online help system for background information on the Remote Volume Mirroring (RVM) premium feature and for software-related procedures to set the configuration of the feature and use it.

Site Preparation

The RVM premium feature can be used only with Fibre Channel host connections. You *must* have Fibre Channel switches to use RVM and to create a fabric environment for data replication. These switches require only minimal additional site preparation requirements beyond basic storage array operation.

For additional site preparation considerations for Fibre Channel switches, including power requirements and physical dimensions and requirements, refer to the documentation that is provided by the switch manufacturer.

Switch Zoning Overview

Because of possible restrictions at the host level, the supported Remote Volume Mirroring configurations contain Fibre Channel switches. These Fibre Channel switches are zoned so that a single host adapter can access only one controller per storage array. Additionally, all configurations use a separate zone for the ports that are reserved for the Remote Volume Mirroring premium feature.



NOTE Do not zone the uplink port (E_port) that connects (cascades) switches within a fabric.

Switch zoning configurations are typically set up by using the switch management software that is provided by the manufacturer of the Fibre Channel switch. This software should have been included with the materials that are provided when the switch was purchased.

When two or more Fibre Channel switches are cascaded together, the switch management software combines the ports for all of the switches that are linked. For example, if two 16-port Fibre Channel switches are cascaded with a physical connection using a Fibre Channel cable, the switch management software shows ports 0 through 31 participating in the fabric rather than two switches each with ports 0 through 15. Therefore, a zone that is created containing any of these ports can exist on multiple cascaded switches.

The following figure shows both cascaded and non-cascaded switches. The top-half of the figure shows a set of cascaded switches that are on the same network. Therefore, Zone 1 is the same zone on Switch 1A as Zone 1 is on Switch 1B. In a single-mode Fibre Channel environment, the two switches are connected by a single port on each switch that is designated as an E_port, which is not in a zone.

The set of switches in the bottom half of the following figure is on the same network but is not cascaded. Although both sets contain a Zone 1 (shown as Zone A in Switch 2), these zones are independent of each other.

Switch Zoning in Cascaded and non-Cascaded Fibre Channel Switches

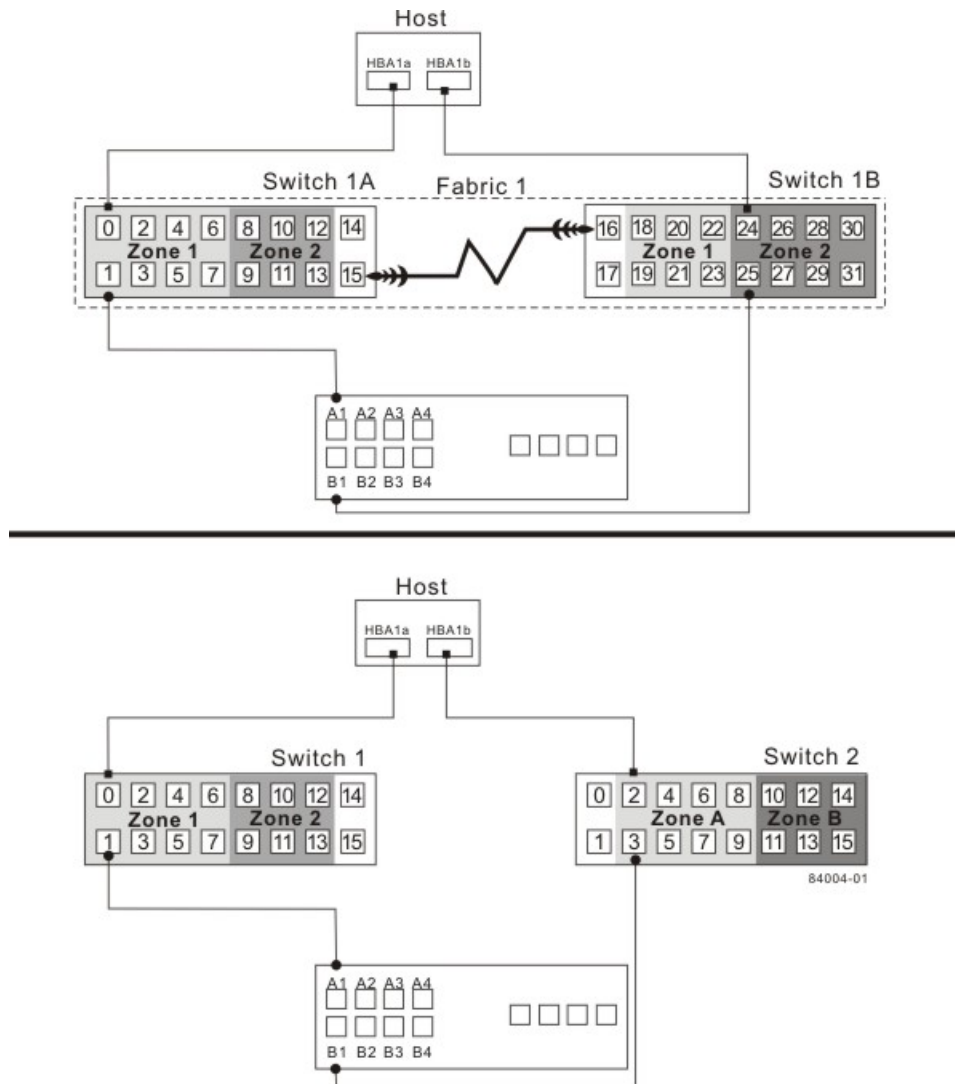

For more information about Fibre Channel switch zoning or setting up a zone configuration, refer to the manufacturer's documentation that is provided with the switch.

Because of the varying Remote Volume Mirroring configurations, the switch zone settings are presented preceding each configuration in this appendix.

Hardware Installation

Select one of the following configuration options to connect and configure one or more storage arrays for use with the Remote Volume Mirroring premium feature.

Configuration Options for Remote Volume Mirroring

| Configuration | Description |
|---|--|
| Highest availability campus configuration (recommended) | <p>This configuration has the greatest redundancy. It is the most stable of the three configurations.</p> <ul style="list-style-type: none"> ▪ Two Fibre Channel switches (for a total of four) at both the primary site and the secondary site provide for complete failover and redundancy in the Fibre Channel switches and fabrics, in addition to all storage array components and hosts. ▪ A single point of failure does not exist in this configuration, and it is the recommended configuration for the Remote Volume Mirroring premium feature. <p>Go to Highest Availability Campus Configuration – Recommended.</p> |
| Campus configuration | <p>The campus configuration is a lower-cost configuration than the highest availability campus configuration. Only one Fibre Channel switch at the primary site and one at the secondary site exist, for a total of two switches. This configuration essentially allows the minimum required components to successfully operate the Remote Volume Mirroring premium feature between two sites.</p> <ul style="list-style-type: none"> ▪ The number of Fibre Channel switches is reduced from four to two and the number of fabrics from two to one. ▪ This configuration is redundant for host bus adapters, controllers, and Remote Volume Mirroring ports, but it has a single point of failure for switches and fabric. ▪ A switch failure does not usually result in a loss of data, but it does affect data synchronization until the error is corrected. Therefore, the highest availability campus configuration is the recommended configuration, because data synchronization can continue for any single switch failure. <p>Go to Campus Configuration.</p> |
| Intra-site configuration | <p>The intra-site configuration is the lowest-cost configuration of all three configurations. It is used in environments where a long-distance fabric is not required because of the close proximity of the hosts and storage arrays.</p> <ul style="list-style-type: none"> ▪ Because the intra-site configuration only has two switches, it is similar to the campus configuration. However, multiple-switch fabrics do not exist in this configuration. ▪ The configuration is redundant for host bus adapters, controllers, Remote Volume Mirroring ports, and switches but is a single point of failure for the site because all of the equipment can be destroyed by the same disaster. ▪ The highest availability campus configuration is the recommended configuration, because it is fully redundant, which makes disaster recovery easier. <p>Go to Intra-Site Configuration.</p> |

Highest Availability Campus Configuration – Recommended



NOTE The highest availability campus configuration is the recommended configuration for the Remote Volume Mirroring premium feature.

This configuration has two Fibre Channel switches at the primary site and two Fibre Channel switches at the secondary site (four switches total), which provide for complete failover and redundancy. Failures could involve Fibre Channel switches, Fibre Channel cables, and any host or storage array. Two Fibre Channel switches at each site also provide redundancy to the local site in addition to a fully redundant remote configuration. No single point of failure exists in the hardware components.

The following figure shows the highest availability campus configuration. The controller trays are shown schematically with four host ports on each of two controllers in each controller tray. In this configuration, use the A4 connection and the B4 connection for remote mirroring traffic instead of the A2 connection and the B2 connection. You can use controller ports A2, A3, B2, and B3 for additional host access if needed.

Highest Availability Campus Configuration Using CE6994 Controller Trays

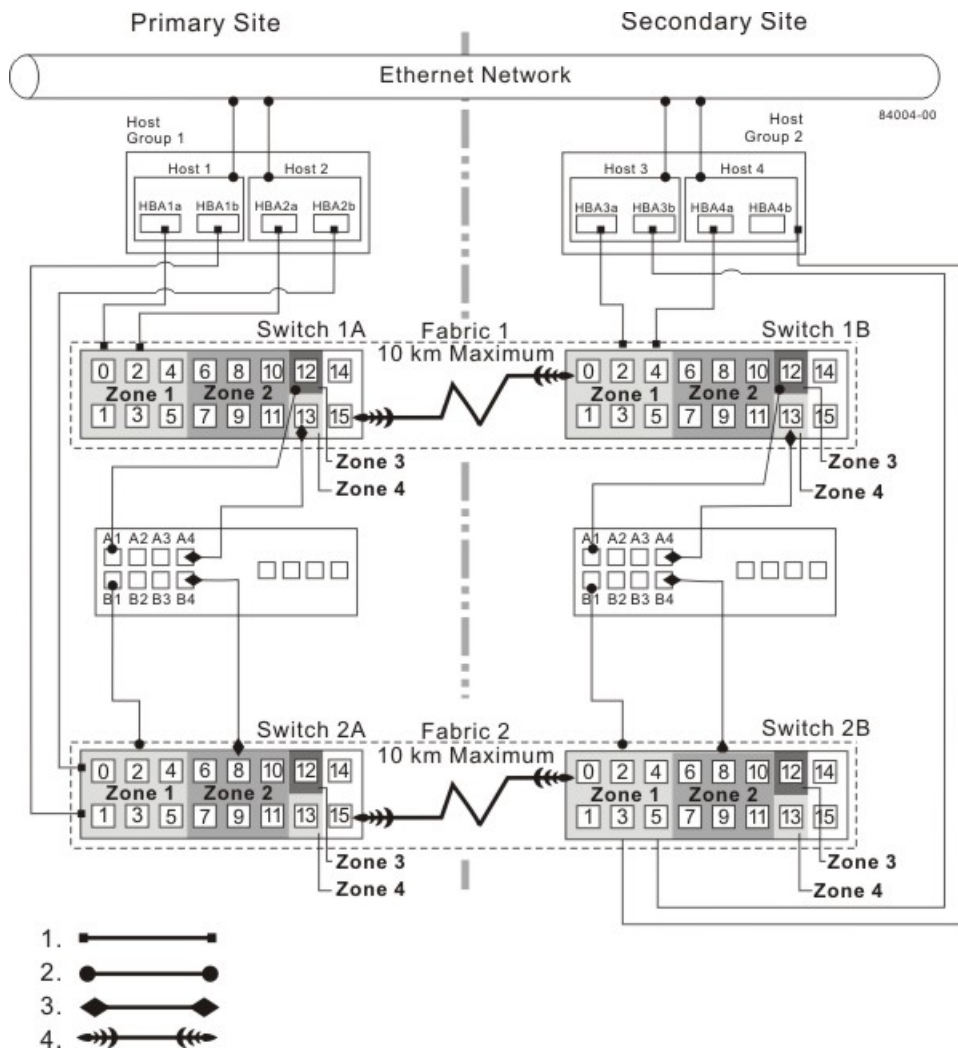

1. Host Fibre Channel Cable
2. Storage Array Fibre Channel Cable
3. Fibre Channel Cable Dedicated for the Remote Volume Mirroring Premium Feature
4. Fabric Uplink Cable

Switch Zoning for Highest Availability Campus Configuration

The highest availability campus configuration provides a separate zone for each reserved port for the Remote Volume Mirroring premium feature.

The switches do not need to be zoned exactly as presented in this configuration. However, you must meet the following requirements when zoning switches for the highest availability campus configuration.

There are a total of four zones in this configuration.

- Zone 1 and zone 3 are on fabric 1 (switch 1A at the primary site, and switch 1B at the secondary site).
- Zone 2 and zone 4 are on fabric 2 (switch 2A at the primary site, and switch 2B at the secondary site).

Configure the zones on the switch so that there is one port per zone for a storage array connection and one port per zone for each host. Switches are zoned so that a single host bus adapter port can access only one controller per storage array.

Switches are zoned so that a single host bus adapter port can access only one controller for each storage array.



NOTE Do not zone the uplink ports (E_ports) on any of the Fibre Channel switches.

The following figure shows how the four switches are zoned for the highest availability campus configuration.

The switches have 16 ports each, which leaves unused ports on each switch when following the preceding requirements. The remaining ports can be distributed among the other zones. It is recommended, however, that most of the remaining ports be assigned to the zones containing the host connections: zone 1 and zone 2. This port assignment allows easy setup for additional hosts to connect to the environment.

Switch Zoning for the Highest Availability Campus Configuration

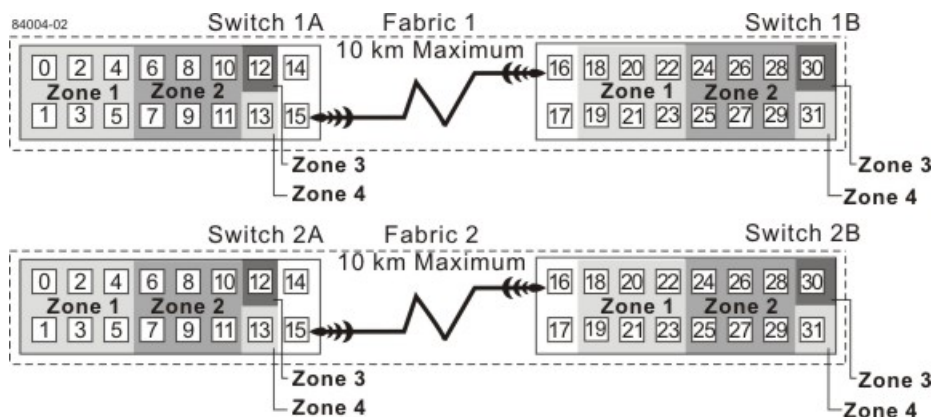

Before you proceed, review the requirements listed in this section and the zoning shown in the figure to make sure that all four switches are correctly zoned. For more information, see the [Switch Zoning Overview](#).

Cabling for the Highest Availability Campus Configuration



NOTE Start the installation at the primary site. Repeat these steps for the secondary site when instructed to do so.

After the four Fibre Channel switches are correctly zoned, complete this procedure to set up the highest availability campus configuration for the Remote Volume Mirroring premium feature.



NOTE Complete all connections by using Fibre Channel cables of the correct length.

- Are you adding equipment for the Remote Volume Mirroring premium feature to an existing storage array environment?
 - Yes** – Stop I/O activity from all hosts before proceeding. Go to step 2.
 - No** – The storage array installation is new. Go to step 3.



ATTENTION Possible hardware damage – DC-powered controller-drive trays and drive trays have special power procedures that you *must* follow beyond the procedures for AC-powered trays. To get specific power-off and power-on procedures, refer to the topics under the storage array installation for the hardware that you are installing or to the corresponding PDF document on the SANtricity ES Storage Manager Installation DVD.

2. Turn off the power to all storage arrays, hosts, Fibre Channel switches, and any other equipment in the storage array environment.
3. Make sure that cabling between all of the controller trays or controller-drive trays and the drive trays is complete.



NOTE Depending on which site is being configured, switch 1 represents switch 1A for the primary site and switch 1B for the secondary site. This representation applies to switch 2 as well.

4. Connect the primary host bus adapter for each local host to an available port in zone 1 of switch 1.
The following figure shows the cabling that is described in step 4 and step 5.

Host Bus Adapter Connections to Fibre Channel Switches

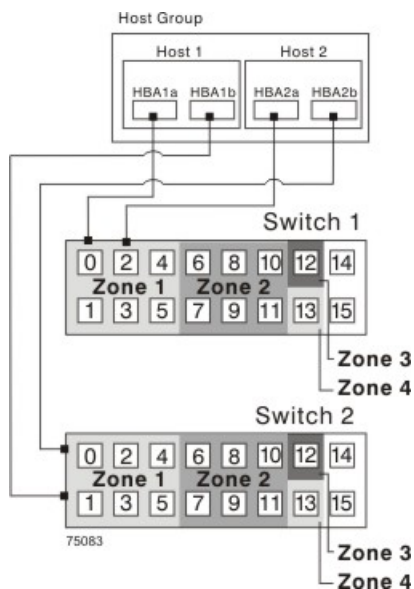

NOTE You can connect the cables to *any* port in the correct zone of the switch for all of the controller trays except the CE6998 controller tray. Host port 4 on each controller of the CE6998 controller trays is reserved for using the Remote Volume Mirroring premium feature. If you are not using the Remote Volume Mirroring premium feature, host port 4 on a CE6998 controller tray is available for host connections.

5. Connect the secondary host bus adapter for each host at this site to an available port in zone 1 of switch 2.
6. Connect controller port A1 of the storage array to an available port in zone 1 of switch 1.
The figure following step 9 shows the cabling for CE6998 controller trays.
7. Connect controller port B1 of the storage array to an available port in zone 1 of switch 2.
8. Connect controller port A2 of the storage array to an available port in zone 2 of switch 1. In a four-host-port system, connect controller port A4 to an available port in zone 2 of switch 1.

9. Connect controller port B2 of the storage array to an available port in zone 2 of switch 2. In a four-host-port system, connect controller port B4 to an available port in zone 2 of switch 2.

Storage Array Connections to Fibre Channel Switches in the CE6998 Controller Tray

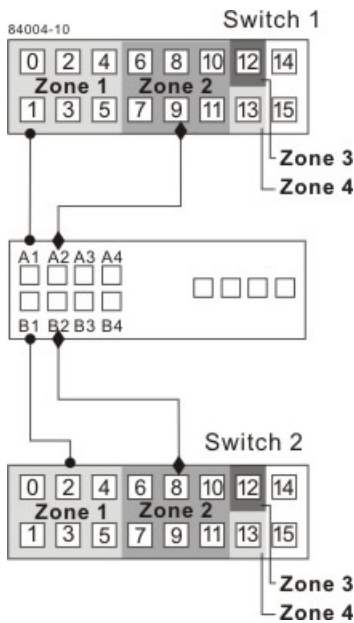

NOTE Controller port A2 and controller port B2 are reserved for mirror relationship synchronization upon activation of the Remote Volume Mirroring premium feature. In a four-host-port system, controller port A4 and controller port B4 are reserved.

10. The primary site cabling is now complete. Is the secondary site cabling complete?
 - **No** – Repeat step 1 through step 9 for the secondary site.
 - **Yes** – Go to step 11.
11. Complete the fabric environment for switch 1 by connecting switch 1A to switch 1B.
The following figure shows the cabling that is described in step 11 and step 12.

Connecting Remote Switches to Complete Fabric Environments

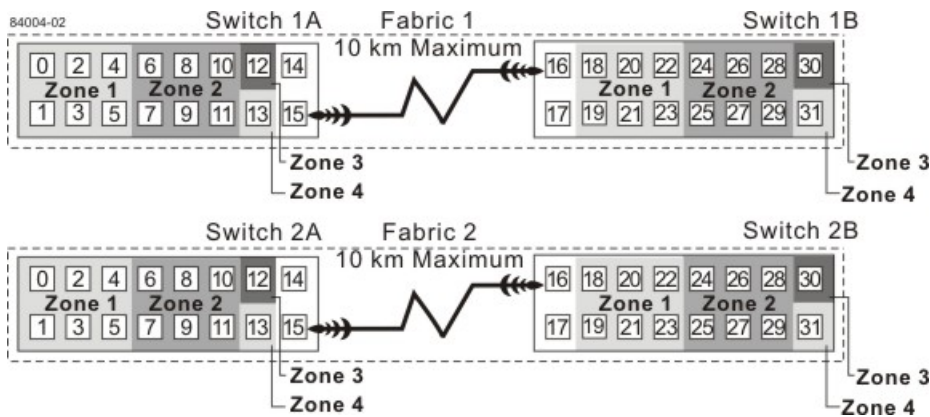

12. Repeat step 11 for switch 2A and switch 2B to complete the fabric environment for switch 2.

13. Cabling for the highest availability campus configuration is complete. Repeat step 4 through step 10 for other storage arrays that exist in the same cabinet that use the Remote Volume Mirroring premium feature.



ATTENTION Possible hardware damage – DC-powered controller-drive trays and drive trays have special power procedures that you *must* follow beyond the procedures for AC-powered trays. To get specific power-off and power-on procedures, refer to the topics under the storage array installation for the hardware that you are installing or to the corresponding PDF document on the SANtricity ES Storage Manager Installation DVD.

14. Turn on the power to all of the storage array hosts, Fibre Channel switches, and any other hardware at both sites where the power was turned off.

The hardware installation is complete. To configure the storage management software to support mirror relationships, refer to the online help topics.

Campus Configuration

The campus configuration offers the same functionality as the highest availability campus configuration, but the campus configuration contains only one switch at each site, rather than two. The configuration is still redundant for host bus adapters, controllers, and remote mirroring ports, but the configuration has a single point of failure for switches. If a switch at either site fails, the Remote Volume Mirroring premium feature cannot operate. For this reason, the highest availability campus configuration is highly recommended for total environment redundancy.

The following figure shows a complete campus configuration. The controller trays are shown schematically with four host ports on each of two controllers in each controller tray.

Campus Configuration

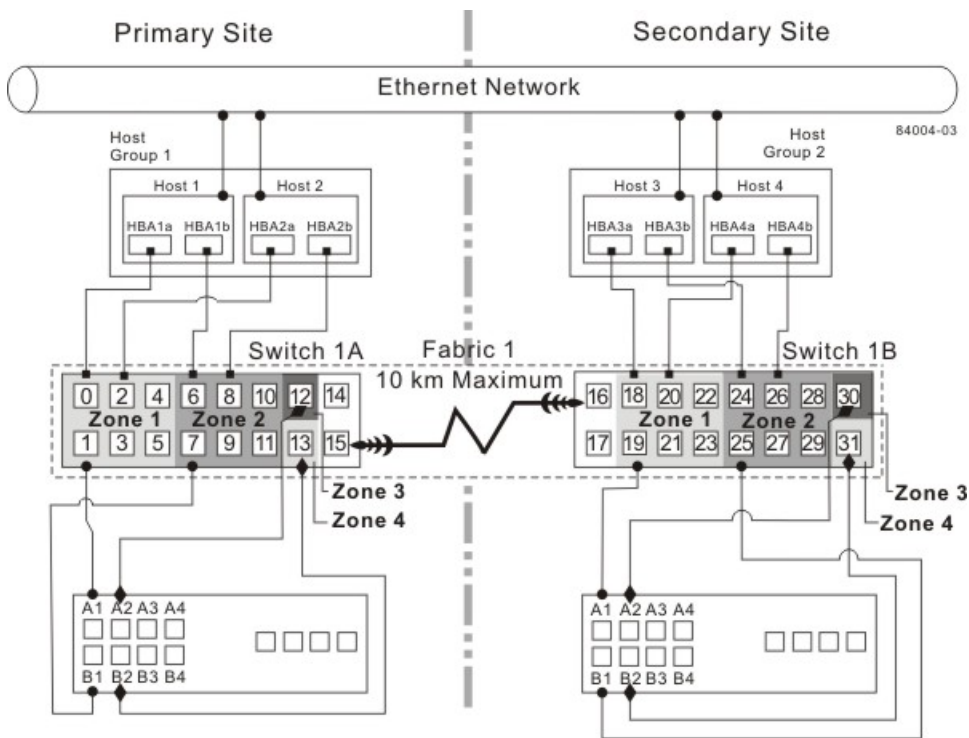

- 1.
- 2.
- 3.
- 4.

1. Host Fibre Channel Cable
2. Storage Array Fibre Channel Cable
3. Fibre Channel Cable Dedicated for the Remote Volume Mirroring Premium Feature
4. Fabric Uplink Cable

Switch Zoning for the Campus Configuration

The campus configuration allows for a separate zone for each reserved port for the Remote Volume Mirroring premium feature.

The switches do not need to be zoned exactly as presented in this configuration. However, you must meet the following requirements when you zone switches for the campus configuration.



NOTE Do not zone the uplink ports (E_ports) on any of the Fibre Channel switches.

You must have a total of four zones in this configuration.

- All zones exist on fabric 1 (switch 1A at the primary site, and switch 1B at the secondary site).
- Zone 3 and zone 4 are reserved for the dedicated Remote Volume Mirroring premium feature connections.

You must configure the zones on the switches so that there is one port per zone for a storage array connection and one port per zone for each host.

You must zone the switches so that a single host adapter can access only one controller per storage array.

The switches in the following figure contain 16 ports each, which leaves many unused ports per switch. The remaining ports can be distributed among the other zones. However, it is recommended that most remaining ports be assigned to the zones that contain the host connections (zone 1). This setup allows connections for additional hosts.

The following figure shows how the two switches are zoned for the campus configuration.

Switch Zoning for the Campus Configuration

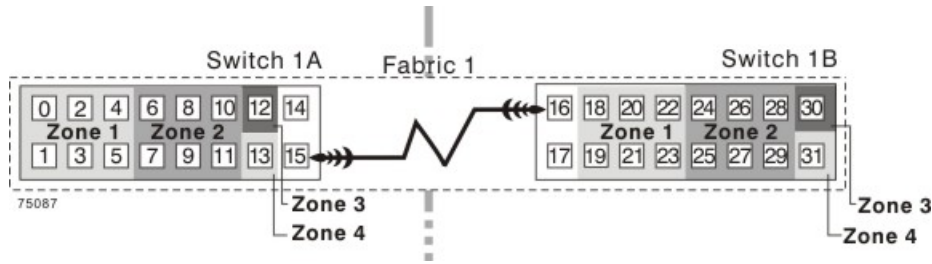

Review the requirements in this section and the zoning example in the figure above to make sure that both switches are correctly zoned before proceeding. For more information, see [Switch Zoning Overview](#).

Cabling for the Campus Configuration

NOTE Start the installation at the primary site. Repeat these steps for the secondary site when instructed to do so.

After both Fibre Channel switches are correctly zoned, complete this procedure to set up the campus configuration for the Remote Volume Mirroring premium feature.

NOTE Complete all connections by using Fibre Channel cables of the correct length.

- Are you adding equipment for the Remote Volume Mirroring premium feature to an existing storage array environment?
 - Yes** – Stop I/O activity from all hosts before proceeding. Go to step 2.
 - No** – This is a new storage array installation. Go to step 3.

ATTENTION Possible hardware damage – DC-powered controller-drive trays and drive trays have special power procedures that you *must* follow beyond the procedures for AC-powered trays. To get specific power-off and power-on procedures, refer to the topics under the storage array installation for the hardware that you are installing or to the corresponding PDF document on the SANtricity ES Storage Manager Installation DVD.

- Turn off the power to all storage arrays, hosts, Fibre Channel switches, and any other equipment in the storage array environment.
- Make sure that basic cabling between all of the controller trays or controller-drive trays and the drive trays on both storage arrays is complete.

NOTE Depending on which site is being configured, switch 1 represents switch 1A for the primary site and switch 1B for the secondary site.



NOTE You can connect the cables to any port in the correct zone of the switch.

4. Connect the primary host bus adapter for each host at this site to an available port in zone 1 of switch 1A.
The following figure shows the cabling that is described in step 4 and step 5.
5. Connect the secondary host bus adapter for each host at this site to an available port in zone 2 of switch 1A.

Host Bus Adapter Connections to Fibre Channel Switches

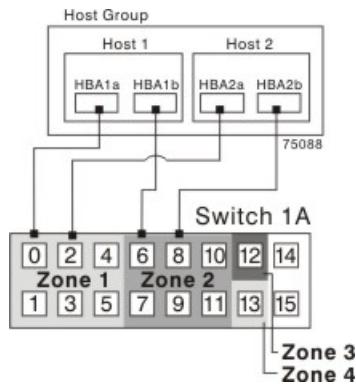

6. Connect controller port A1 of the storage array to an available port in zone 1 of switch 1A.
The first figure following step 9 shows the storage array connected to Fibre Channel switches that is described in step 6 through step 9. The second figure following step 9 shows the cabling configuration schematically with four host ports on each of two controllers in each controller tray.
7. Connect controller port B1 of the storage array to an available port in zone 2 of switch 1A.
8. Connect controller port A2 of the storage array to an available port in zone 3 of switch 1A. In a four-host-port system, connect controller port A4.
9. Connect controller port B2 of the storage array to an available port in zone 4 of switch 1A. In a four-host-port system, connect controller port B4.



NOTE Controller ports A2 and B2 are reserved for mirror relationship synchronization upon activation of the Remote Volume Mirroring premium feature. In a four-host-port system, controller port A4 and controller port B4 are reserved.

Storage Array Connections to Fibre Channel Switches

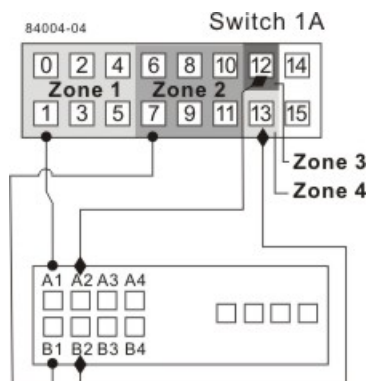

Storage Array Connections to Fibre Channel Switches

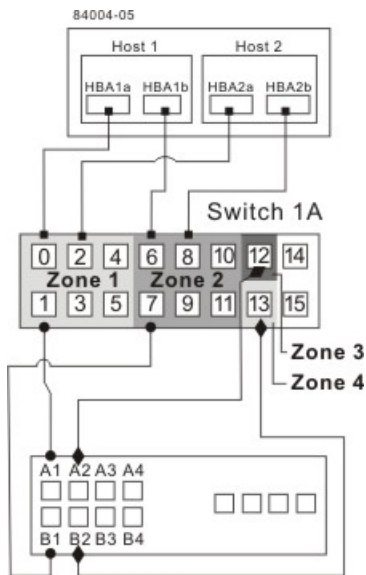

10. The primary site cabling is now complete. Is the secondary site cabling complete?

- **No** – Repeat step 1 through step 9 for the secondary site.
- **Yes** – Go to step 11.

11. Complete fabric 1 by connecting switch 1A to switch 1B.

The following figure shows the cabling that is described in this step.

Connecting Remote Switches to Complete the Fabric Environment

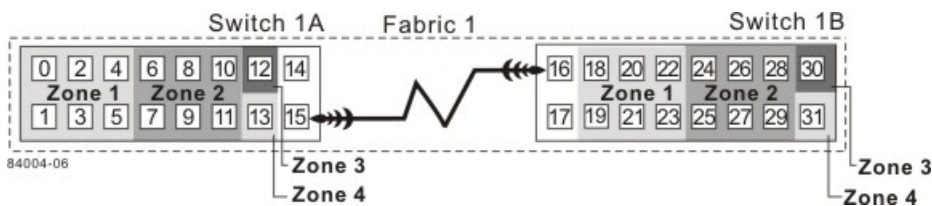

12. Cabling for the campus configuration is complete. Repeat step 4 through step 10 for any additional storage arrays that exist in the same cabinet that will use the Remote Volume Mirroring premium feature.



ATTENTION Possible hardware damage – DC-powered controller-drive trays and drive trays have special power procedures that you *must* follow beyond the procedures for AC-powered trays. To get specific power-off and power-on procedures, refer to the topics under the storage array installation for the hardware that you are installing or to the corresponding PDF document on the SANtricity ES Storage Manager Installation DVD.

13. Turn on the power to all storage arrays, hosts, Fibre Channel switches, and any other hardware at both sites where the power was turned off.
14. Hardware installation is complete. Refer to the online help topics for procedures to configure the storage management software to support mirror relationships.

Intra-Site Configuration

The intra-site configuration is used in environments where a long-distance fabric is not required because of the close proximity of the hosts and storage arrays. The configuration is still redundant for host bus adapters, controllers, remote mirroring ports, and switches, but the configuration is a single point of failure for the site because all of the equipment can be destroyed by the same disaster. For this reason, the highest availability campus configuration is highly recommended for total environment redundancy.

The following figure shows a complete installation of the intra-site configuration.

NOTE A switch failure in this configuration does not affect data access; however, as a result, an Unsynchronized state might occur for all of the mirror relationships on both the primary storage arrays and the secondary storage arrays.

Intra-Site Configuration Following a Complete Installation

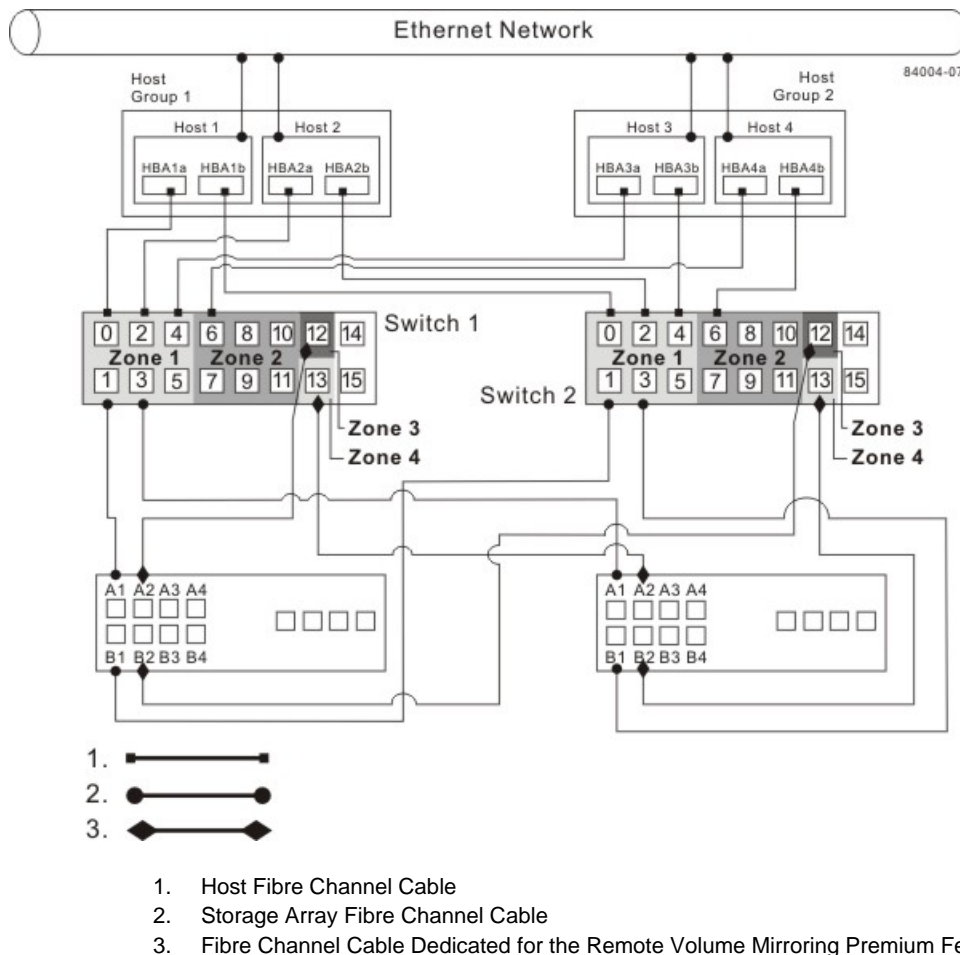

Switch Zoning for the Intra-Site Configuration

The intra-site configuration provides switch redundancy, but the switches are not cascaded and are independent of each other.

NOTE The switches do not need to be zoned exactly as presented in this configuration. However, you must meet the following requirements when zoning switches for the intra-site configuration.

You must have a total of four zones on each controller in this configuration.

You must configure the zones on the switch so that there is one port per zone for a storage array connection and one port per zone for each host.

You must zone the switches so that a single host adapter can only access one controller per storage array.

The switches in the following figure contain 16 ports each, which leaves many unused ports per switch. The remaining ports can be distributed among the other zones. However, it is recommended that most of the remaining ports be assigned to the zones that contain the host connections: zone 1 and zone 2. This assignment allows for easy setup for connecting additional hosts.

For simplicity, in this example, the switches use one-half of the ports for each zone, although zone 3 and zone 4 require fewer ports.

Switch Zoning for the Intra-Site Configuration

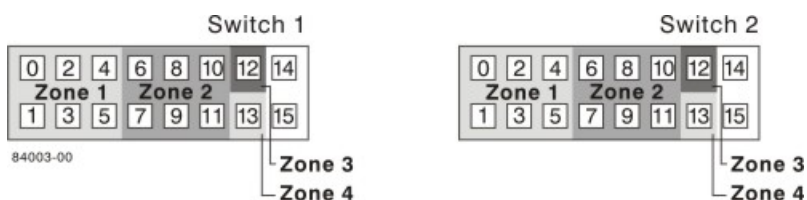

Before proceeding, review the requirements in this section and the zoning example in the figures to make sure that both switches are correctly zoned. For more information, see [Switch Zoning Overview](#).

Cabling for the Intra-Site Configuration

After both Fibre Channel switches are correctly zoned, complete this procedure to set up the intra-site configuration for the Remote Volume Mirroring premium feature.

 **NOTE** Complete all connections by using Fibre Channel cables of the correct length.

1. Are you adding equipment for the Remote Volume Mirroring premium feature to an existing storage array environment?
 - **Yes** – Stop I/O activity from all hosts before proceeding. Go to step 2.
 - **No** – This is a new storage array installation. Go to step 3.

 **ATTENTION Possible hardware damage** – DC-powered controller-drive trays and drive trays have special power procedures that you *must* follow beyond the procedures for AC-powered trays. To get specific power-off and power-on procedures, refer to the topics under the storage array installation for the hardware that you are installing or to the corresponding PDF document on the SANtricity ES Storage Manager Installation DVD.

2. Turn off the power to all storage arrays, hosts, Fibre Channel switches, and any other equipment in the storage array environment.
3. Make sure that basic cabling between all of the controller trays or controller-drive trays and the drive trays is complete on both storage arrays as described in this document.
4. Connect the primary host bus adapter for each host to an available port in zone 1 of switch 1.

The following figure shows the cabling that is described in step 4.



NOTE You can connect the cables to any port in the correct zone of the switch.

Primary Host Bus Adapter Connections to Fibre Channel Switches

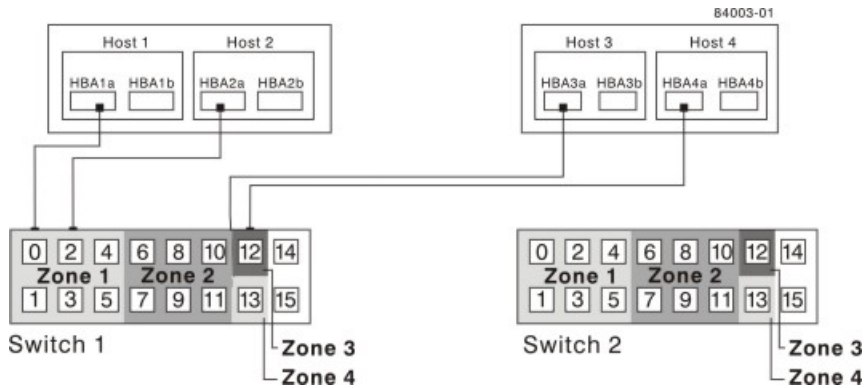

5. Connect the secondary host bus adapter for each host to an available port in zone 1 of switch 2. The following figure shows the cabling that is described in this step.

Secondary Host Bus Adapter Connections to Fibre Channel Switches

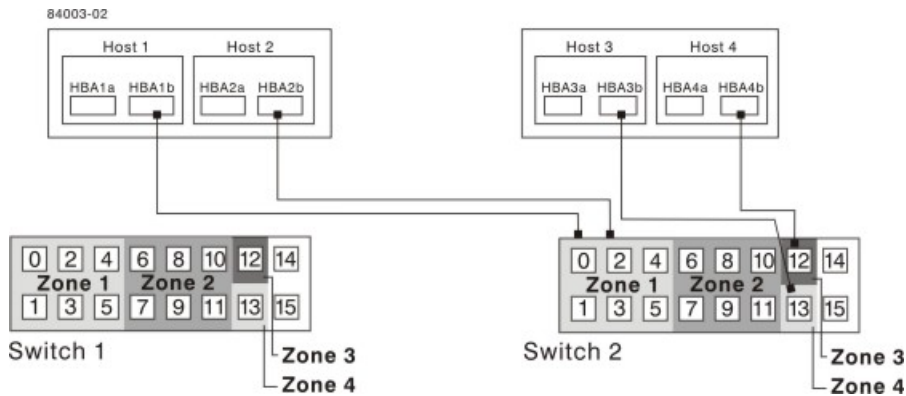

6. Connect controller port A1 of the primary storage array to an available port in zone 1 of switch 1. The following figure shows the cabling that is described in step 6 through step 9.

Primary Storage Array Connections to Fibre Channel Switches

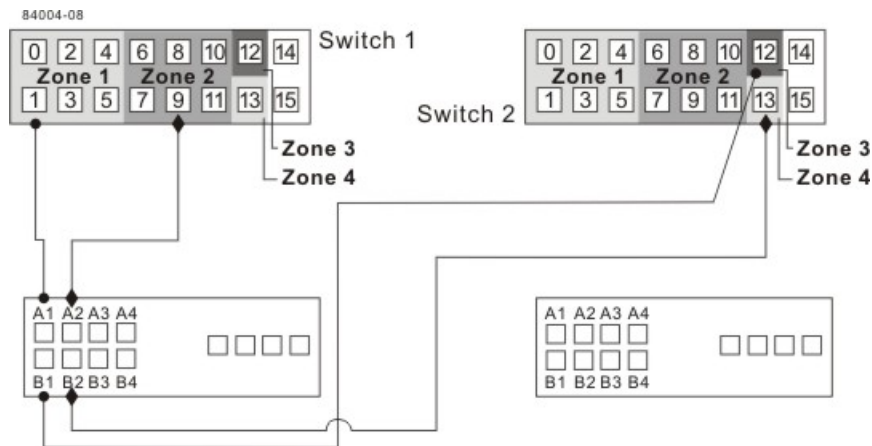

7. Connect controller port B1 of the primary storage array to an available port in zone 3 of switch 2.
8. Connect controller port A2 of the primary storage array to an available port in zone 2 of switch 1. In a four-host-port system, connect controller port A4 to an available port in zone 2 of switch 1.
9. Connect controller port B2 of the primary storage array to an available port in zone 4 of switch 2. In a four-host-port system, connect controller port B4 to an available port in zone 4 of switch 2.



NOTE Upon activation of the Remote Volume Mirroring premium feature, controller port A2 and controller port B2 are reserved for mirror relationship synchronization. In a four-host-port system, controller port A4 and controller port B4 are reserved.

10. Connect controller port A1 of the secondary storage array to an available port in zone 1 of switch 1.
The figure following step 13 shows the cabling described in step 10 through step 13.
11. Connect controller port B1 of the secondary storage array to an available port in zone 3 of switch 2.
12. Connect controller port A2 of the secondary storage array to an available port in zone 2 of switch 1. In a four-host-port system, connect controller port A4 to an available port in zone 2 of switch 1.
13. Connect controller port B2 of the secondary storage array to an available port in zone 4 of switch 2. In a four-host-port system, connect controller port B4 to an available port in zone 4 of switch 2.

Secondary Storage Array Connections to Fibre Channel Switches

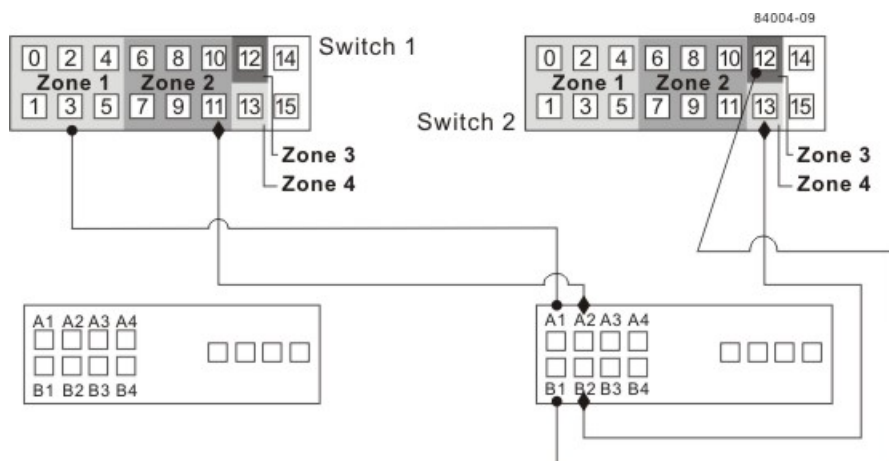

14. Cabling for the intra-site configuration is complete. Repeat step 4 through step 13 for any additional storage arrays that exist in the same cabinet that will use the Remote Volume Mirroring premium feature.



ATTENTION Possible hardware damage – DC-powered controller-drive trays and drive trays have special power procedures that you *must* follow beyond the procedures for AC-powered trays. To get specific power-off and power-on procedures, refer to the topics under the storage array installation for the hardware that you are installing or to the corresponding PDF document on the SANtricity ES Storage Manager Installation DVD.

15. Turn on the power to all storage arrays, hosts, Fibre Channel switches, and any other hardware where power was turned off.
16. The hardware installation is complete. Refer to the online help topics for procedures to configure the storage management software to support mirror relationships.

Installing and Using Remote Volume Mirroring with a Wide Area Network

When installing and using the Remote Volume Mirroring premium feature over a wide area network (WAN), keep these guidelines in mind:

- If you are setting up an FCIP router to perform asynchronous Remote Volume Mirroring, go to the Compatibility Matrix. Select **Router-FCIP** in the **Product** field, and select the release of the storage management software that you use in the **Software Release** field. Verify that the maximum latency and distance are supported by referring to the vendor specifications for your router and by checking the Compatibility Matrix. The Compatibility Matrix is found at <http://www.lsi.com/compatibilitymatrix/>.
- FCIP router vendors and telecommunication vendors are responsible for setting up routing.
- The smaller the bandwidth on the WAN, the longer it takes an asynchronous mirror to synchronize.
- If the bandwidth does not exceed the average rate, you might not be able to synchronize the data at all. For example, if the system writes at 1 Mb/s, it needs 2 Mb/s of bandwidth available.
- If the mirroring is lagging far behind during production hours, suspend the mirror. During off-peak hours, resume the mirror.
- If you need to keep the Remote Volume Mirroring on at all times, keep the mirror physically as close as possible to the production site.
- To determine the average write rate, you should use the available system utilities and should take measurements during peak times.
- If you anticipate adding any applications, determine the bandwidth needs for any future applications.
- Acceptable lag times vary depending on the environment and should be determined on an individual basis.

Line Capacities

Line Capacities and Line Speeds

| Line Type | Capacity in Mb/s | Speed in MB/s |
|-----------|------------------|---------------|
| T-1 | 1.544 | 0.193 |
| T-3 | 43.232 | 5.404 |
| OC-3 | 155.6352 | 19.454 |

| Line Type | Capacity in Mb/s | Speed in MB/s |
|-----------|------------------|---------------|
| OC-12 | 622.5408 | 77.8176 |
| OC-48 | 2490.1632 | 311.27 |
| OC-192 | 9960.6528 | 1245.085 |

The following table shows average write operations in Mb/s with corresponding line capacity calculations. When the line capacity calculation is below 50 percent, the result is an adequate response-time performance and a limited need for delta logging (when the mirror lags behind the data). When the line capacity calculation is above 50 percent, the mirror can never catch up. Any transfers above 50 percent will start to lag.

Line Capacity Calculation for Various Write I/O Rates

| Average Write Time in Mb/s | T-1 | T-3 | OC-3 | OC-12 | OC-18 | OC-192 |
|----------------------------|---------|--------|-------|-------|-------|--------|
| 0.01 | 5.2% | 0.2% | 0.1% | 0.0% | 0.0% | 0.0% |
| 0.1 | 51.8% | 1.9% | 0.5% | 0.1% | 0.0% | 0.0% |
| 1 | 518.1% | 18.5% | 5.1% | 1.3% | 0.3% | 0.1% |
| 10 | 5181.3% | 185.3% | 51.4% | 12.9% | 3.2% | 0.8% |

Initial Configuration and Software Installation

This document describes the tasks necessary for installing and starting SANtricity ES Storage Manager for Version 10.80, and then performing initial configuration on your storage array. Consult this topic after configuring and cabling the storage array through one of the hardware configuration guides for the CE7900 controller tray, the CE2600 controller-drive tray, the CE2600-60 controller-drive tray, the CE4900 controller-drive tray, the CE5400 controller-drive tray, or the CE5400-60 controller-drive tray.

Step 1 – Deciding on the Management Method

You can manage a storage array using the in-band method, the out-of-band method, or both.



NOTE You need to know the storage management method that you plan to use before you install the SANtricity ES Storage Manager software and use the storage management software.

Key Terms

access volume

A special volume that is used by the host-agent software to communicate management requests and event information between the management station and the storage array. An access volume is required only for in-band management.

Dynamic Host Configuration Protocol (DHCP)

CONTEXT [Network] An Internet protocol that allows nodes to dynamically acquire ('lease') network addresses for periods of time rather than having to pre-configure them. DHCP greatly simplifies the administration of large networks, and networks in which nodes frequently join and depart. (The Dictionary of Storage Networking Terminology)

in-band management

A method to manage a storage array in which a storage management station sends commands to the storage array through the host input/output (I/O) connection to the controller.

out-of-band management

A method to manage a storage array in which a storage management station sends commands to the storage array through the Ethernet connections on the controller.

stateless address autoconfiguration

A method for setting the Internet Protocol (IP) address of an Ethernet port automatically. This method is applicable only for IPv6 networks.

World Wide Identifier (WWID)

CONTEXT [Fibre Channel] A unique 64-bit number assigned by a recognized naming authority (often using a block assignment to a manufacturer) that identifies a node process or node port. A WWID is assigned for the life of a connection (device). Most networking physical transport network technologies use a world wide unique identifier convention. For example, the Ethernet Media Access Control Identifier is often referred to as the MAC address. (The Dictionary of Storage Networking Terminology)

Procedure – Management Method



NOTE If you use the out-of-band management method but do not have a DHCP server, you must manually configure your controllers. See [“Step 10 – Manually Configuring the Controllers”](#) for details.

1. Use the key terms and the following figures to determine the management method that you will use.
2. After reading the information in this section, add a check mark next to the management method that you will use.

- ___ In-band management method
- ___ Out-of-band management method
- ___ In-band management method and out-of-band management method



NOTE A host system with a host bus adapter (HBA) can run the storage management software; you do not need to install the management client on a separate client system

In-Band Management Topology

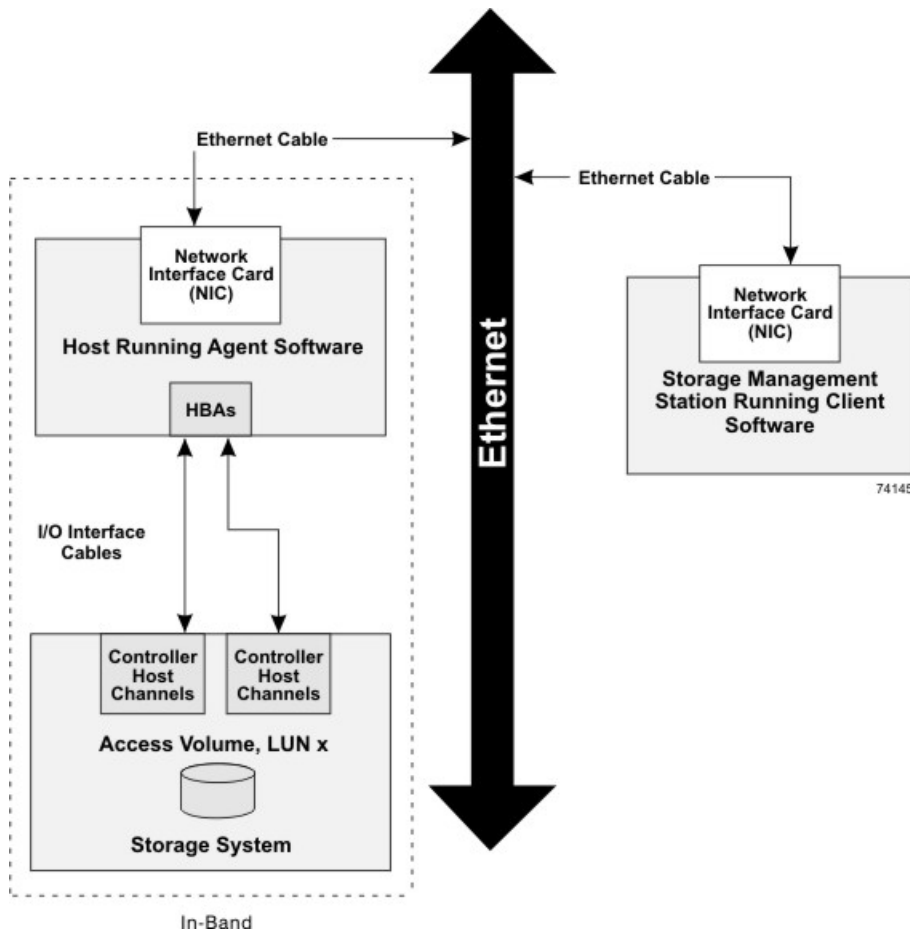

Out-of-Band Management Topology

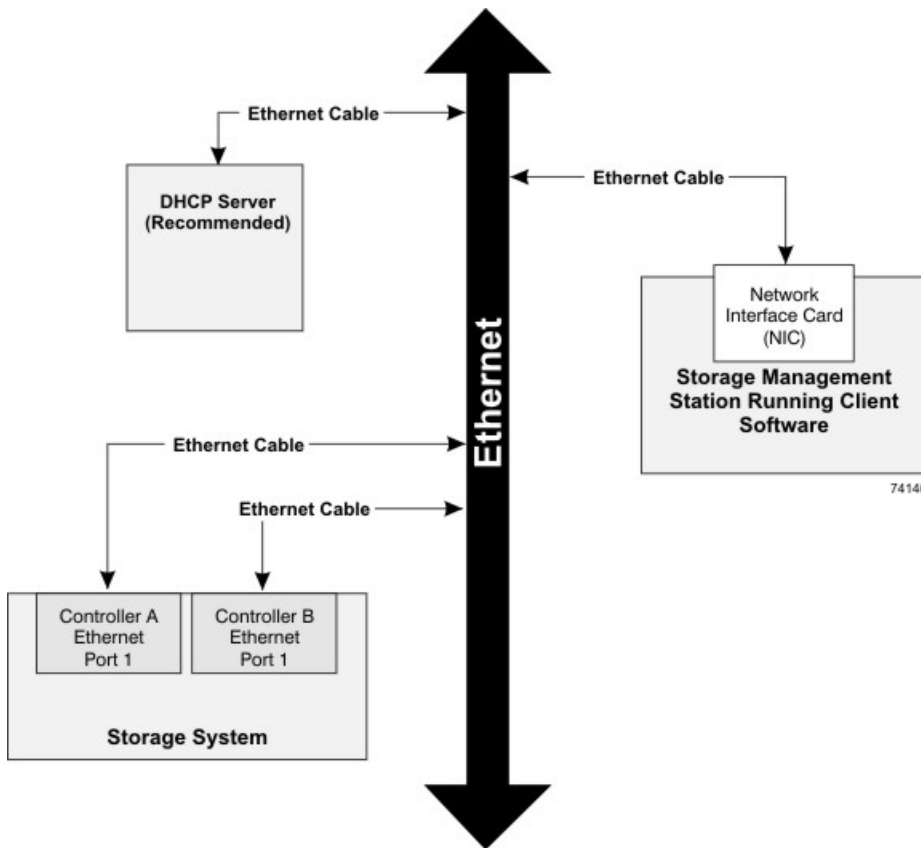

Things to Know – In-Band and Out-of-Band Requirements

Out-of-Band and In-Band Management Requirements

| Management Method | Requirements | Advantages | Disadvantages |
|--|---|---|--|
| Out-of-band <i>without</i> a DHCP server | Connect separate Ethernet cables to each controller. Manually configure the network settings on the controllers. See "Manually Configuring the Controllers" for more information. | This method does not use a logical unit number (LUN) on the host. You do not need to install the host-agent software. This method does not use the SAS, Fibre Channel, or iSCSI bandwidth for storage array management functions. | You must manually configure the network settings on the controllers. Ethernet cables are required. |

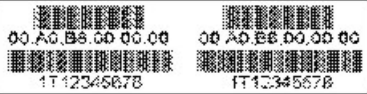
| Management Method | Requirements | Advantages | Disadvantages |
|--|--|--|--------------------------------------|
| <p>Out-of-band – IPv6 stateless address auto-configuration <i>without</i> a DHCP server (IPv6 networks only)</p> | <p>Connect separate Ethernet cables to each controller. Connect at least one router for sending the IPv6 network address prefix in the form of router advertisements.</p> | <p>No additional manual network configuration is required on the controllers. By default, the controllers automatically obtain their IP addresses by combining the auto-generated link local address and the IPv6 network address prefix after you turn on the power to the controller-drive tray. You do not need to install host-agent software. This method does not use a LUN on the host. This method does not use the Fibre Channel or iSCSI bandwidth for storage array management functions.</p> | <p>Ethernet cables are required.</p> |
| <p>Out-of-band <i>with</i> a DHCP server (IPv4 networks only)</p> | <p>Connect separate Ethernet cables to each controller. Assign either static IP addresses or dynamic IP addresses to the controllers. It is recommended that you assign static IP addresses. Check your DHCP server for the IP addresses that are associated with the media access control (MAC) addresses of the controllers. The MAC address appears on a label on each controller in the form: <i>xx.xx.xx.xx.xx.xx</i>.</p> <div data-bbox="516 1627 906 1726" style="border: 1px solid black; padding: 5px; text-align: center;">  <p>00:AD:B5:00:00:00 00:AD:B5:00:00:00 1T12345678 1T12345678</p> </div> | <p>No additional manual network configuration is required on the controllers. By default, the controllers automatically obtain their IP addresses from the DHCP server after you turn on the power to the controller-drive tray. You do not need to install host-agent software. This method does not use a LUN on the host. This method does not use the Fibre Channel or iSCSI bandwidth for storage array management functions.</p> | <p>Ethernet cables are required.</p> |

| Management Method | Requirements | Advantages | Disadvantages |
|--------------------------|---|---|---|
| In-band | Install host-agent software on at least one of the network-attached hosts. The host-agent software is included with the storage management software. This method requires a special access volume to communicate. This volume is created automatically. | No additional manual network configuration is required on the controller. | This method uses both a LUN on the host and the Fibre Channel bandwidth for storage array management functions. |

Step 2 – Setting Up the Storage Array for Windows Server 2008 Server Core

If your host is running Windows Server 2008 Server Core, use the procedures in this section to configure your storage array. Before you perform the procedures in this section, make sure that you have completed the relevant hardware configuration.

- If your host is not running Windows Server 2008 Core, go to "[Step 3 – Installing the SANtricity ES Storage Manager Software](#)" to continue the installation.
- If your host is running Windows Server 2008 Server Core, you must use the command line and the procedures in this topic to install and configure your storage array.

If you are using iSCSI host connections, perform the procedures in this section to configure the iSCSI initiator and to install the storage management software:

1. Configure the network interfaces.
2. Set the iSCSI initiator services.
3. Install the storage management software (in lieu of completing the task from [Step 3 – Installing the SANtricity ES Storage Manager Software](#)).
4. Configure the iSCSI ports.
5. Configure and view the targets.
6. Establish a persistent login to a target.
7. Verify your iSCSI configuration.
8. Review other useful iSCSI commands.
9. Configure your storage array.

Refer to the *Microsoft iSCSI Software Initiator 2.x Users Guide* for more information about the commands used in these steps. Refer to the Microsoft Developers Network (MSDN) for more information about Windows Server 2008 Server Core. You can access these resources from www.microsoft.com.

If you are using either Fibre Channel or SAS host connections, you must also perform these additional procedures:

1. Install the storage management software using [Step 3 – Installing the SANtricity ES Storage Manager Software](#).
2. Configure your storage array using [Step 17 – Configuring the Storage](#).

Procedure – Configuring the Network Interfaces

1. Find the index for the iSCSI initiator by typing one of these commands and pressing **Enter**:

- C:\>netsh interface ipv4 show interfaces
- C:\>netsh interface ipv6 show interfaces

A list of all found interfaces appears:

| Idx | Met | MTU | State | Name |
|-----|-----|------------|-----------|-----------------------------|
| 2 | 10 | 1500 | connected | Local Area Connection |
| 1 | 50 | 4294967295 | connected | Loopback Pseudo-Interface 1 |

| | | | | |
|---|----|------|-----------|-------------------------|
| 3 | 20 | 1500 | connected | Local Area Connection 2 |
| 4 | 20 | 1500 | connected | Local Area Connection 3 |

2. Set the IP address for the initiators.

For IPv4 initiators, type these commands from the command line:

- C:\Users\administrator>netsh interface ipv4 set address name=3 source=static address=192.168.0.1 mask=255.255.255.0
- C:\Users\administrator>netsh interface ipv4 set address name=4 source=static address=192.168.1.1 mask=255.255.255.0

For IPv6 initiators, type these commands from the command line:

- C:\Users\administrator>netsh interface ipv6 set address name=3 source=static address=<IPv6 address> mask=255.255.255.0
- C:\Users\administrator>netsh interface ipv6 set address name=4 source=static address=<IPv6 address> mask=255.255.255.0

In the previous two commands, <IPv6 address> is the IPv6 address for the iSCSI initiator.

Procedure – Setting the iSCSI Initiator Services

Set the iSCSI initiator services to start automatically. From the command line, type this command:

```
sc\server_name config msiscsi start=auto
```

In this command, *server_name* is the name of the host.

Procedure – Installing the Storage Management Software

The SANtricity ES Storage Manager executable is located on the SANtricity ES Storage Manager Installation DVD.

1. Insert the DVD into the host DVD drive.
2. Locate the installation package that you want to install. From the command line, type one of these commands:

```
<hsw executable.exe> -i console
```

```
<hsw executable.exe> -i silent
```

In these commands, <hsw executable.exe> is the file name for the storage management software installation package.

When you specify the `console` parameter during the installation, questions appear on the console that enable you to choose installation variables. This installation does not use a graphical user interface (GUI). Contact your Customer and Technical Support representative if you need to change the installation options.

When you specify the `silent` parameter during the installation, the command installs the storage management software using all of the defaults. A silent installation uses a resource file that contains all of the required information, and it does not return any windows until the installation is complete. This installation does not use a graphical user interface (GUI). Contact your Customer and Technical Support representative if you need to change the installation options.

3. Make sure that the appropriate files are listed in the installation directory.

A full installation should include these directories:

- util (SMutil)
- client (SMclient)
- agent (SMagent)

4. Type this SMcli command without options to make sure that SMcli was installed correctly.

```
SMcli <controller_A_IP_address> <controller_B_IP_address>
```



NOTE In the Windows operating system, you must perform this command from the `client` directory.

5. Make sure that an Incorrect Usage message is returned with a list of allowable SMcli options.



NOTE To make sure that your configuration settings take effect, you must reboot the host before starting the storage management software.

Procedure – Configuring the iSCSI Ports

Use the command line interface that is included in the storage management software to configure the iSCSI ports. Refer to either the *Command Line Interface and Script Commands for Version 10.77* electronic document topics or the PDF on the SANtricity ES Storage Manager Installation DVD for instructions on how to configure the iSCSI ports. The information in the programming guide applies to the SANtricity ES Storage Manager software. You must complete these tasks:

1. Show a list of unconfigured iSCSI initiators.
2. Create an iSCSI initiator.
3. Set the iSCSI initiator.
4. Set the iSCSI target properties.
5. Show the current iSCSI sessions.

Procedure – Configuring and Viewing the Targets

Configure a target and, optionally, persist that target. You must configure each port on the target one time. If you are using Challenge-Handshake Authentication Protocol (CHAP), you can also establish a CHAP user name and password when you configure the target.

1. Are you using CHAP?
 - If yes, go to [step 3](#).
 - If no, go to [step 2](#).
2. If you are *not* using CHAP, type this command for each port on the target from the command line. When you are finished, go to [step 4](#).

```
iscsicli QAddTargetPortal <IP Address Target Controller>
```

In this command, *<IP Address Target Controller>* is the IP address for the target port that you are configuring.

3. If you *are* using CHAP, type this command for each port on the target from the command line. When you are finished, go to [step 4](#).

```
iscsicli QAddTargetPortal <IP Address Target Controller> <CHAP Username> <CHAP Password>
```

In this command:

- *<IP Address Target Controller>* is the IP address for the target port that you are configuring.
 - *<CHAP Username>* and *<CHAP Password>* are the optional user name and password for the target port that you are configuring.
4. After you have configured all of the ports on the target, you can show a list of all configured targets. From the command line, type this command:

```
iscsicli ListTargets
```

A list of all found targets appears.

Procedure – Establishing a Persistent Login to a Target

You can establish a persistent login to a target. A persistent login is the set of information required by an initiator to log in to the target each time the initiator device is started. The login usually occurs when you start the host. You cannot initiate a login to the target until after the host has finished rebooting. You must establish a persistent login for each initiator-target combination or initiator-target path. This command requires 18 parameters. Several of the parameters use the default values and are indicated with *. Refer to the *Microsoft iSCSI Software Initiator 2.x Users Guide* for a description of this command and the parameters.

From the command line, type this command:

```
iscsicli PersistentLoginTarget <Target Name> <ReportToPNP> <TargetPortalAddress>  
<TCPPortNumberofTargetPortal> * * * <Login Flags> * * * * * * * * * <MappingCount>
```

In this command:

- *<Target Name>* is the name of your target port as shown in the targets list.
- *<ReportToPNP>* is set to **T**, which exposes the LUN to the operating system as a storage device.
- *<TargetPortalAddress>* is the IP address for the target port.
- *<TCPPortNumberofTargetPortal>* is set to **3260**, which is the port number defined for use by iSCSI.
- *<Login Flags>* is set to **0x2**, which allows more than one session to be logged into a target at one time.
- *<MappingCount>* is set to **0**, which indicates that no mappings are specified and no further parameters are required.
- * uses the default value for that parameter.



NOTE To make sure that your configuration settings take effect, you must reboot the host before continuing with these tasks.

Procedure – Verifying Your iSCSI Configuration

After you reboot the host, you can verify your configuration.

From the command line, type this command:

```
iscsici ListPersistentTargets
```

A list of persistent targets configured for all iSCSI initiators appears. Make sure that “Multipath Enabled” appears in the output under Login Flags.

Procedure – Reviewing Other Useful iSCSI Commands

The commands listed in this section are useful for managing the iSCSI targets and iSCSI initiators.

This command shows the set of target mappings assigned to all of the LUNs to which all of the iSCSI initiators are logged in.

```
iscsicli ReportTargetMappings
```

This command shows a list of active sessions for all iSCSI initiators.

```
iscsicli sessionlist
```

This command sends a **SCSI REPORT LUNS** command to a target.

```
iscsicli ReportLUNS <SessionId>
```

This command removes a target from the list of persistent targets.

```
iscsicli RemovePersistentTarget <Initiator Name> <TargetName>  
<Initiator Port Number> <Target Portal Address> <Target Portal Socket>
```

These commands and others are described in the *Microsoft iSCSI Software Initiator 2.x Users Guide*.

Procedure – Configuring Your Storage Array

You have these methods for configuring your storage array:

- You can configure the storage array from a storage management station that is on the same network as the storage array. This method is preferred. Continue to Go to [Step 4 – Configuring the Host Bus Adapters](#), and then make sure that you complete the “[Step 17 – Configuring the Storage](#)” to finish configuring your storage array.
- You also can configure the storage array using the command line interface. Refer to “Configuring a Storage Array” in the *Configuring and Maintaining a Storage Array Using the Command Line* electronic document topic or on the PDF on the SANtricity ES Storage Manager Installation DVD for information that will help you configure your storage array.

Step 3 – Installing the SANtricity ES Storage Manager Software

If you are running Windows Server 2008 Server Core, make sure that you have performed the tasks in [Step 2 – Setting Up the Storage Array for Windows Server 2008 Server Core](#). If you are not running Windows Server 2008u Server Core, start with the tasks in this step.

Key Terms

host

A computer that is attached to a storage array. A host accesses volumes assigned to it on the storage array. The access is through the HBA host ports or through the iSCSI host ports on the storage array.

monitor

A software package that monitors the storage array and reports critical events.

multi-path driver

A driver that manages the input/output (I/O) data connection for storage arrays with redundant controllers. If a component (cable, controller, host adapter, and so on) fails along with the I/O data connection, the multi-path driver automatically reroutes all I/O operations to the other controller.

Redundant Dual Active Controller (RDAC) multi-path driver

A driver that manages the I/O data connection for storage arrays with dual controllers in a redundant configuration. If a component fails along the connections, causing the host to lose communication with a controller, the driver automatically reroutes all I/O operations to the other controller.

storage management station

A computer running storage management software that adds, monitors, and manages the storage arrays on a network.

Things to Know – All Operating Systems

This section describes how to use the installation wizard to install the SANtricity ES Storage Manager software (hereinafter referred to as the storage management software). The separate native installation packages are supplied on the SANtricity ES Storage Manager Installation DVD in the `native` directory.

For the Windows Server 2003 operating system (OS), the Windows Server 2008 OS, the Linux OS, the Solaris OS, and VMware, the storage management software supports using the storage array as a boot device. For assistance with setting up this configuration, contact your Customer and Technical Support representative.



NOTE If the Windows Server 2003 OS, the Windows Server 2008 OS, or the Linux OS is installed on a computer with an Intel Itanium 2 (IA64) processor, you cannot use the storage array as a boot device.

Things to Know – Specific Operating Systems

Solaris OS:

- The Solaris OS supports the use of the Multiplexed I/O (MPxIO) driver.

- The Solaris OS supports the use of the Sun Cluster software for clustering.

Windows XP OS and Windows Vista OS:

- These operating systems support the SANtricity ES Storage Manager Client package only.
- Other storage management software packages are not available on the Window XP OS and the Windows Vista OS, including the failover driver.
- Systems running these operating systems can be used only as storage management stations.
- Providers for Microsoft Virtual Disk Service (DVDS), Microsoft Volume Shadow Copy Service (VSS), and Storage Networking Industry Association (SNIA) are not supported on these operating systems.

Windows Server 2003 OS SP2 R2 and Windows Server 2008 OS R2 SP1:

- When the RDAC multi-path driver is not installed, the **Install Complete** window shows an error message that states that the installation is finished and that some warnings exist. The message suggests looking at the installation log for details. The installation log contains a warning that a Win32 exception can be found. This behavior is normal and expected. The installation was successful.
- These operating systems support the use of the Microsoft Multi-Path I/O (MPIO) driver for failover.

Linux Red Hat 5.6 Client OS, Linux Red Hat 6 Client OS, SUSE Desktop 10 OS, and SUSE Desktop 11.1 OS:

- These operating systems support only the SANtricity ES Storage Manager Client package.
- Other storage management software packages are not available on the Linux Red Hat 5 Client OS and the SUSE Desktop 11.1 OS, including the failover driver.
- Systems running these operating systems can be used only as storage management stations.

Red Hat Enterprise Linux OS and SUSE Linux Enterprise Server OS:

- These operating systems support the use of the LSI RDAC multi-path driver for failover.
- Both the Linux Red Hat 6 Client OS and the SUSE Desktop 11.1 OS also support the native device mapper application.
- These operating systems support the use of the SteelEye® LifeKeeper and Native Red Hat Clustering software for clustering.

Things to Know – System Requirements

The following tables describe the operating system specifications, memory requirements, and disk space requirements.

Operating System Version or Edition Requirements

| Operating System | System and Version or Edition |
|----------------------------|--|
| Windows XP | x86-based system (32-bit and 64-bit) Pentium or greater CPU or equivalent (233 MHz minimum) Professional Service Pack 3 (SP3) or later NOTE – Storage management station only. |
| Windows Server 2003 SP2 R2 | Standard Server Edition system (32-bit and 64-bit) Enterprise Edition, (32-bit and 64-bit) Datacenter Edition, (32-bit and 64-bit) |

| Operating System | System and Version or Edition |
|--|---|
| | x64 Edition (AMD and EM64T support) x86-based system (AMD64 and EM64T) Web Edition (client only version with no failover support) |
| Windows Vista | SP1 x86-based system (32-bit and 64-bit) Pentium or greater CPU or equivalent (800 MHz minimum) NOTE – Storage management station only. |
| Windows Server 2008 R2 SP1 | x86-based system (64-bit only: AMD64 and EM64T) Standard Server and Core Edition Enterprise Server and Core Edition Datacenter Server and Core Edition Foundation Server and Core Edition Web Edition (client only version with no failover support) |
| Windows Hyper-V Server 2008 R2 SP1(standalone) | x86-based system (64-bit only: AMD64 and EM64T) |
| VMware | 3.5u5+P20 ^a 4.1 AMD64 and EM64T |
| Macintosh OS X | 10.5.8 10.6.3 Intel Xeon x86 64-bit support only |
| Linux | Intel Xeon EM64T and AMD Opteron 32-bit and 64-bit processors Red Hat Enterprise Linux 5.5 Red Hat Enterprise Linux 6.0 SUSE Linux Enterprise Server 10 SP 3 SUSE Linux Enterprise Server 11 SP1 Client only versions (all 32-bit only with no I/O attach): <ul style="list-style-type: none"> ▪ Red Hat Enterprise Linux 5.0 client ▪ Red Hat Enterprise Linux 6.0 client ▪ SUSE Linux Enterprise Server 10 client ▪ SUSE Linux Enterprise Server 11 client |
| Linux (Infiniband) | Red Hat Enterprise Linux 6.0 (Mellanox driver) SUSE Linux Enterprise Server 11 SP1 (Mellanox driver) Support only for 64-bit versions of the operating systems (EM64T and AMDx86) Client only versions: <ul style="list-style-type: none"> ▪ Red Hat Enterprise Linux 5.0 client ▪ Red Hat Enterprise Linux 6.0 client ▪ SUSE Linux Enterprise Server 10 client ▪ SUSE Linux Enterprise Server 11 client |
| HP-UX | 11.31 March 2010 (IA64 and PA-RISC) Fibre Channel only (direct connection) |

| Operating System | System and Version or Edition |
|---|--|
| Solaris | SPARC-based system x86-based system (Intel Xeon, and 32-bit AMD Opteron or 64-bit AMD Opteron) Solaris 10 Update 9 |
| ^a The VMware 3.5 OS does not support configurations with any versions of the CE5400 controller-drive tray. | |

Temporary Disk Space Requirements

| Operating System | Available Temporary Disk Space | Other Requirements |
|---------------------|--------------------------------|--------------------|
| Windows XP | 255 MB | — |
| Windows Server 2003 | 291 MB | — |
| Windows Vista | 291 MB | — |
| Windows Server 2008 | 291 MB | — |
| Linux | 390 MB | — |
| HP-UX | 582 MB | — |
| Solaris | 540 MB | — |

 **NOTE** The minimum RAM requirement is 512 MB.

Procedure – Installing the SANtricity ES Storage Manager Software

 **NOTE** Make sure that you have the correct administrator or superuser privileges to install the software.

1. Insert the SANtricity ES Storage Manager Installation DVD in the DVD drive.
Depending on your operating system, a program autoplays and shows a menu with installation selections. If the menu does not appear, you must perform these tasks:
 - a. Manually open the `install` folder.
 - b. Locate the installation package that you want to install.
2. Install the software installation packages that are required for your storage configuration.
You might be required to open a window or terminal to run one of these commands.
 - `hsw_executable.exe -i console`
 - `hsw_executable.exe -i silent`
 In the commands, `hsw_executable.exe` is the file name for the storage management software installation package.
 - When using the `console` parameter during the installation, questions appear on the console that enable you to choose installation variables. This installation does not use a graphical user interface (GUI). Contact your Customer and Technical Support representative if you need to change the installation options.

- When using the `silent` parameter during the installation, the command installs the storage management software using all of the defaults. A silent installation uses a resource file that contains all of the required information, and it does not return any windows until the installation is complete. This installation does not use a GUI. Contact your Customer and Technical Support representative if you need to change the installation options.

Example: These examples show the actual command used to launch the installation wizard for a particular operating system.

- **Windows operating systems** – Double-click the executable file. In general, the executable file begins with SMIA followed by the operating system name, such as `SMIA-WS32.exe`.
- **UNIX operating systems** – At the command prompt, type the applicable command to start the installer, and press Enter. For example, type a command that is similar to this command: `sh DVD_name.bin`. In this command, `DVD_name.bin` is the name of the installation DVD, such as `SMIA-LINUX.bin`.



NOTE If necessary, set the display environment to issue the command.

Example: Use the information in the on-screen instructions to install the software.

Things to Know – Software Packages

Client – This package contains the graphical user interface for managing the storage array. This package also contains a monitor service that sends alerts when a critical problem exists with the storage array.



NOTE You can add from one to eight clients to your storage configuration.

Utilities – This package contains utilities that let the operating system recognize the volumes that you create on the storage array and to view the operating system-specific device names for each volume.

Agent – This package contains software that allows a management station to communicate with the controllers in the storage array over the I/O path of a host (see [Things to Know – In-Band and Out-of-Band Requirements](#)).

Failover driver – This package contains the multi-path driver that manages the I/O paths into the controllers in the storage array. If a problem exists on the path or a failure occurs on one of the controllers, the driver automatically reroutes the request from the hosts to the other controller in the storage array.

Java Access Bridge (JAB) – This package contains accessibility software that enables Windows-based assistive technology to access and interact with the client application.



NOTE The Microsoft Virtual Disk Service (VDS) and Volume Shadow Copy Service (VSS) providers are a part of the SANtricity ES Storage Manager package for the Windows Server 2003 OS and the Windows Server 2008 OS.

Use the figures and tables that follow to determine the software packages that should be installed on each machine. You must install the utilities and the failover driver on each host that is attached to the storage array.



NOTE If you choose not to automatically enable the event monitor during installation, you will not receive critical alert notifications.

NOTE During the client installation, you are asked whether you want to start the monitor. Start the monitor on only one host that runs continuously. If you start the monitor on more than one host, you receive duplicate alert notifications about problems with the storage array.

Software Configurations

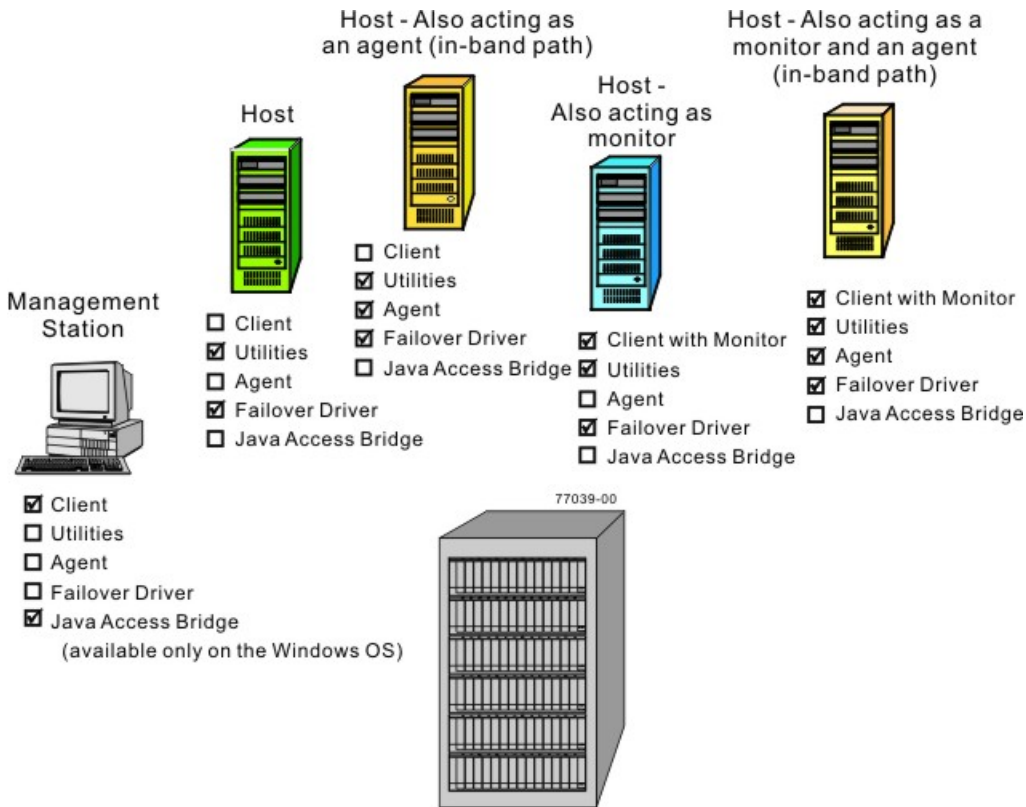

The storage array is the box at the bottom of this figure.

Different Machines and Required Software

| Machine | Minimum Software Required | Installation Package (Choose One) (See the tables that follow) | Notes |
|--------------------|--|--|--|
| Management station | Client | <ul style="list-style-type: none"> Typical Installation Management Station Custom | <ul style="list-style-type: none"> Click No to the prompt, Automatically start Monitor? You must choose Custom if you want to install the Java Access Bridge software. |
| Host | <ul style="list-style-type: none"> Utilities Failover driver | <ul style="list-style-type: none"> Typical Installation Host Custom | <ul style="list-style-type: none"> Click No to the prompt, Automatically start Monitor? |

| Machine | Minimum Software Required | Installation Package (Choose One) (See the tables that follow) | Notes |
|--|---|--|--|
| | | | <ul style="list-style-type: none"> Be aware that some operating systems require the manual installation of the RDAC failover driver. |
| Host – Also acting as an agent for the in-band management method | <ul style="list-style-type: none"> Utilities Agent Failover driver | <ul style="list-style-type: none"> Typical Installation Host Custom | Click No to the prompt, Automatically start Monitor? |
| Host – Also acting as a monitor for sending critical alerts | <ul style="list-style-type: none"> Client Utilities Failover driver | <ul style="list-style-type: none"> Typical Installation Custom | <ul style="list-style-type: none"> Click Yes to the prompt, Automatically start Monitor? Start the monitor on only one host that will run continuously. |
| Host – Also acting as an agent for the in-band management method and a monitor for sending critical alerts | <ul style="list-style-type: none"> Client Utilities Agent Failover driver | <ul style="list-style-type: none"> Typical Installation Custom | <ul style="list-style-type: none"> Click Yes to the prompt, Automatically start Monitor? Start the monitor on only one host that will run continuously. |

Installation Wizard Selections

| Type of Installation | Client | Utilities | Agent | Failover | JAB ^a |
|----------------------------------|--------|-----------|-------|----------|------------------|
| Typical Installation | X | X | X | X | — |
| Management Station | X | — | — | — | — |
| Host Station | — | X | X | X | — |
| Custom (you select the packages) | X | X | X | X | X |

^a Java Access Bridge – Enables Windows OS-based assistive technology to access and interact with the application.

Software Packages That Are Supported on Each Operating System

| Operating System | Client | Utilities | Agent | Failover | JAB |
|---|--------|-----------|-------|----------|-----|
| Windows XP Professional SP3 and Windows Vista | X | — | — | — | X |

| Operating System | Client | Utilities | Agent | Failover | JAB |
|--|----------------|----------------|-------|---------------------|----------------|
| Windows Server 2003 and Windows Server 2008 | X | X | X | X | X |
| VMware 3.5 and 4.1 | X | X ^a | X | X | — |
| Red Hat 5.0 Client and SUSE Linux Enterprise Desktop 10 | X | — | — | X | — |
| Red Hat 6.0 Client and SUSE Linux Enterprise Desktop 11.1 | X | — | — | X | — |
| Red Hat Enterprise Linux and SUSE Linux Enterprise Server | X | X | X | Manual ^b | — |
| Solaris | X | X | X | X | — |
| Macintosh 10.5.8 and 10.6.3 | — | X | X | X | X ^d |
| HP-UX 11.31 (FC only) | X ^c | X | X | X | — |
| <p>^aIf the Management client is run on a guest operating system, the only supported utility is SMdevices on an iSCSI HBA when the storage is directly attached to the guest operating system.</p> <p>^b Refer to <i>Failover Drivers</i> and the "Making Sure that RDAC is Installed Correctly on the Linux OS" topic.</p> <p>^c Both the Windows client and the Linux client are supported as well.</p> <p>^d I/O attach only.</p> | | | | | |

Procedure – Manually Installing RDAC on the Linux OS

1. To change to the directory where the RDAC source was untarred, type this command, and press Enter:

```
cd linuxrdac
```



NOTE For more information about installing RDAC, refer to the `Readme.txt` file in the `linuxrdac` directory.

2. To clean the directory, type this command, and press Enter:

```
make clean
```

3. To compile the trays, type this command, and press Enter:

make

4. To install RDAC, type this command, and press Enter:

```
make install
```

5. After the make installation is completed, modify your bootloader configuration file.

For more information about modifying the bootloader configuration, refer to the output from the **make install** command for Linux RDAC.

6. Read the `Readme.txt` file in the `linuxrdac` directory to complete the RDAC installation process.
7. Reboot or start your host.

Step 4 – Configuring the Host Bus Adapters

A host bus adapter (HBA) is an adapter on the information bus of the host computer. This adapter acts as a bridge and provides connectivity between both the host computer and the storage. Host bus adapters free up critical server processing time. Depending on the configuration of your storage array, you must set up the HBA to enable storage access using Fibre Channel (FC), iSCSI, SAS, or Infiniband connections. In addition, some operating system (OS) and failover driver settings may be necessary to make sure that your storage array runs properly.

Procedure – Configuring the HBAs

This section provides information about configuring your operating systems, failover drivers, and HBA settings for Fibre Channel (FC), iSCSI, and SAS protocols.

Use the following table to determine whether you need to make operating system, failover driver, or software initiator changes for your configuration. You will first need to make any operating systems changes, then alter failover driver settings, and finally make changes to the appropriate HBA, so work from left to right, using the appropriate settings for your particular configuration.



NOTE 'No Change' indicates that you do not need to modify the default settings, while 'Not applicable' indicates that the failover driver or software initiator does not apply to that particular operating system.

Configuration Changes for Operating Systems, Failover Drivers, and HBAs

| Operating Systems | Failover Drivers | FC Host Adapter | SAS Host Adapter Protocol | iSCSI Host Adapter or Software Initiator Protocol |
|----------------------------------|--|---|---------------------------|---|
| Linux with MPP Failover Drivers | MPP Failover Driver Configuration Changes | <ul style="list-style-type: none"> ▪ Linux OS FC Brocade HBA Changes for the MPP Failover Driver ▪ Linux FC Emulex HBA Changes for MPP Failover Driver ▪ Linux FC QLogic HBA Changes for MPP Failover Driver | SAS HBA Setting Changes | Linux iSCSI Protocol Settings for the HBAs with the MPP Failover Driver |
| Linux with DMMP Failover Drivers | Configuration Changes for Linux OS using DMMP Driver | <ul style="list-style-type: none"> ▪ Linux OS FC Brocade HBA Changes for DMMP Failover Driver | SAS HBA Setting Changes | Linux OS DMMP Failover Driver Configuration Changes |

| Operating Systems | Failover Drivers | FC Host Adapter | SAS Host Adapter Protocol | iSCSI Host Adapter or Software Initiator Protocol |
|-----------------------------------|---|--|-----------------------------------|--|
| | | <ul style="list-style-type: none"> ▪ Linux OS FC Emulex HBA Changes for DMMP Failover Driver ▪ Linux OS FC QLogic HBA Changes for DMMP Failover Driver | | |
| Windows | Configuration Changes for Windows using DMMP Driver | <ul style="list-style-type: none"> ▪ FC Brocade Changes for Windows ▪ FC Emulex Changes for Windows ▪ FC QLogic Changes for Windows | SAS HBA Setting Changes | iSCSI HBA Settings for the Windows OS |
| VMware with ESX 3.5 or ESX 4.1 | No change is required to any of the failover driver settings. | QLogic FC HBA Settings on the VMware OS No change is required to any of the Emulex FC HBA settings. | SAS HBA Changes for the VMware OS | No change is required to the iSCSI HBA with ESX 3.5. iSCSI Host Adapter Changes for the VMware OS |
| HP-UX HP-UX OS Changes for HBA | Not applicable | No changes are required to the HP-UX FC HBA settings. | Not applicable | Not applicable |
| Sun Solaris | Sun Solaris systems use the MPXIO failover driver, which requires no changes. | No changes are required to either the QLogic or the Emulex HBA settings. | Not applicable | Not applicable |

Things to Know – Changing to Linux Operating System Settings, Failover Driver Settings, and HBA Settings for DMMP

Use the following table to determine the changes required by the Linux operating systems to either failover drivers or HBA settings when using the DMMP failover driver.

Linux OS DMMP Failover Driver Configuration Changes

| Linux OS DMMP Failover Driver Configuration Changes |
|--|
| <p>Setting name: <code>dev_loss_tmo</code> Default value: 10 Recommended value: 15 Setting location: <code>/etc/multipath.conf</code> Comments: Driver time-out value.</p> |
| <p>Setting name: <code>failback</code> Default value: manual failback Recommended value: 10 Setting location: <code>/etc/multipath.conf</code> Comments: This change applies to non-cluster configurations only. For cluster configurations, do not change this value from the default.</p> |
| <p>Setting name: <code>fast_io_fail_tmo</code> Default value: 5 Recommended value: 10 Setting location: <code>/etc/multipath.conf</code> Comments: The midlayer uses either this value or the <code>dev_loss_tmo</code>, whichever is set to a lower value. If fast failover is set, some errors normally retried by the driver are immediately transferred to the alternate path.</p> |
| <p>Setting name: <code>features</code> Recommended value: <code>2 pg_init_retries 50</code> Setting location: <code>/etc/multipath.conf</code> Comments: This parameter allows for a higher number of mode-select retries, because the SLES 11.0 OS transfers only one LUN at a time.</p> |
| <p>Setting name: <code>getuid_callout</code> Default value: <code>"/lib/udev/scsi_id -- whitelisted -- device=/dev/%n"</code> Recommended value: <code>"/lib/udev/scsi_id -g -u -d/dev/%n"</code> Setting location: <code>/etc/multipath.conf</code></p> |
| <p>Setting name: <code>hardware_handler</code> Recommended value: <code>1 rdac</code> Setting location: <code>/etc/multipath.conf</code> Comments: This parameter sets the rdac device handler.</p> |
| <p>Setting name: <code>no_path_retry</code> Default value: 0 Recommended value: 30 Setting location: <code>/etc/multipath.conf</code> Comments: This midlayer uses either this setting or the <code>dev_loss_tmo</code> (whichever value is lower). If a fast failover is set, some errors that are normally retried by the driver are transferred to the alternate path.</p> |
| <p>Setting name: <code>path_checker</code> Default value: <code>directio</code> Recommended value: <code>rdac</code> Setting location: <code>/etc/multipath.conf</code></p> |
| <p>Setting name: <code>path_grouping_policy</code> Default value: <code>multibus</code></p> |

| Linux OS DMMP Failover Driver Configuration Changes |
|--|
| Recommended value: <code>group_by_prio</code> Setting location: <code>/etc/multipath.conf</code> |
| Setting name: <code>path_selector</code> Default value: <code>round-robin 0</code> Recommended value: <code>round-robin 0</code> Setting location: <code>/etc/multipath.conf</code> |
| Setting name: <code>polling_interval</code> Default value: <code>5</code> Recommended value: <code>5</code> Setting location: <code>/etc/multipath.conf</code> |
| Setting name: <code>prio</code> Recommended value: <code>rdac</code> Setting location: <code>/etc/multipath.conf</code> |
| Setting name: <code>rr_min_io</code> Default value: <code>1000</code> Recommended value: <code>100</code> Setting location: <code>/etc/multipath.conf</code> |
| Setting name: <code>rr_weight</code> Default value: <code>uniform</code> Recommended value: <code>priorities</code> Setting location: <code>/etc/multipath.conf</code> |

Linux OS FC Brocade HBA Changes for DMMP Failover Driver

| Setting Changes |
|--|
| Setting name: <code>path_tov</code> Default value: <code>0x1E</code> Recommended value: <code>0xA</code> |

Linux OS FC Emulex HBA Changes for DMMP Failover Driver

| Setting Changes |
|--|
| Setting name: <code>lpfc_devloss_tmo</code> Recommended value: <code>10</code> Setting location: <ul style="list-style-type: none"> ▪ For the SLES11.0 OS and all subsequent releases: <code>/etc/modprobe.conf.local</code> ▪ For the RHEL6 OS: <code>/etc/modprobe.d/</code> with <code>"options lpfc_devloss_tmo=10"</code> |

Linux OS FC QLogic HBA Changes for DMMP Failover Driver

| Setting Changes |
|--|
| Setting name: <code>qlport_down_retry</code> |

| Setting Changes |
|---|
| Recommended value: 10 Setting location: <ul style="list-style-type: none"> ▪ For SLES11.0 and all subsequent releases: <code>/etc/modprobe.conf.local</code> ▪ For RHEL6: <code>/etc/modprobe.d/</code> with <code>"options qla2xxx qlport_down_retry=10"</code> |

Linux OS iSCSI HBA Changes for DMMP Failover Driver

| Setting Changes |
|---|
| Setting name: <code>node.session.timeo.replacement_timeout</code> Default value: 120 Recommended value: 20 Setting location: <code>/etc/iscsi/iscsid.conf</code> |
| Setting name: <code>node.startup</code> Recommended value: <code>automatic</code> Setting location: <code>/etc/iscsi/iscsid.conf</code> |
| Setting name: <code>noop_out_interval</code> Recommended value: 5 Setting location: <code>/etc/iscsi/iscsid.conf</code> |
| Setting name: <code>noop_out_timeout</code> Recommended value: 5 Setting location: <code>/etc/iscsi/iscsid.conf</code> |

Things to Know – Changing the Linux Failover Driver and HBA Settings for MPP

Use the following table to determine the changes required by the Linux MPP failover driver and the HBAs.

MPP Failover Driver Configuration Changes

| Setting Changes |
|--|
| Setting name: <code>DisableLunRebalance</code> Default value: <code>0x0</code> Recommended value: <code>0x3</code> Setting location: <code>/etc/mpp.conf</code> Comments: This setting applies only to cluster configurations. |

Linux OS FC Brocade HBA Changes for the MPP Failover Driver

| Setting Changes |
|--|
| Setting name: <code>rport_del_timeout</code> Default value: <code>0x5a</code> Recommended value: 60 Setting location: <code>/etc/modprobe.conf</code> |

Linux FC Emulex HBA Changes for MPP Failover Driver

| Setting Changes |
|--|
| Setting name: <code>LinkTimeOut</code> Default value: 30 Recommended value: 60 Setting location: Use the Emulex HBAnyware application to change the location setting. |
| Setting name: <code>NodeTimeOut</code> Default value: <code>0x1E</code> Recommended value: <code>0X3c</code> Setting location: Use the Emulex HBAnyware application to change the location setting. |

Linux FC QLogic HBA Changes for MPP Failover Driver

| Setting Changes |
|--|
| Setting name: <code>ExecutionThrottle</code> Default value: 0 Recommended value: 256 Setting location: Change this setting with both the QLogic BIOS for the in-the-box driver. Use the QLogic SANsurfer application for the standard driver. |
| Setting name: <code>qlport_down_retry</code> Default value: 30 Recommended value: 70 Setting location: <code>/etc/modprobe.conf</code> . Comments: Add " <code>options qlport_down_retry=70</code> " to the setting. |

Linux iSCSI Protocol Settings for the HBAs with the MPP Failover Driver

| Setting Changes |
|---|
| Setting name: <code>node.session.timeo.replacement_timeout</code> Default value: 120 Recommended value: 144 Setting location: <ul style="list-style-type: none"> ▪ For the SLES 11.0, the RHEL5 OS, and the RHEL6 OS: <code>/etc/iscsi/iscsid.conf</code> ▪ For SLES 10.0: <code>/etc/iscsid.conf</code> |
| Setting name: <code>node.startup</code> Recommended value: <code>automatic</code> Setting location: <ul style="list-style-type: none"> ▪ For the SLES 11.0 OS, the RHEL5 OS, and the RHEL6 OS: <code>/etc/iscsi/iscsid.conf</code> ▪ For the SLES 10.0 OS: <code>/etc/iscsid.conf</code> |

Things to Know – Changing Windows FC and iSCSI HBA Settings

Use the following tables to determine the changes required by the Windows OS to either failover drivers or HBA settings.

Windows OS Configuration Changes for FC and iSCSI HBAs

| Component | Setting Changes |
|---------------------------------|---|
| Windows Server 2003 OS settings | Setting name: IO Timeout Value Default value: 0x14 Recommended value: 0x78 Recommended value when using iSCSI HBA: 0xA0 Setting location: HKEY_LOCAL_MACHINE\SYSTEM\CurrentControlSet\Services\disk |
| Windows Server 2008 OS settings | Setting name: IO Timeout Value Default value: 0x14 Recommended value: 0x3c Setting location: HKEY_LOCAL_MACHINE\SYSTEM\CurrentControlSet\Services\disk |

Windows Server 2003 OS and Windows Server 2008 OS MPIO/DSM Failover Driver Settings

| Component | Setting Changes |
|---|---|
| MPIO/DSM failover driver settings for the Windows Server 2003 OS and the Windows Server 2008 OS | Setting name: DisableLunRebalance Default value: 0x0 Recommended value: 0x3 Setting location: HKEY_LOCAL_MACHINE\SYSTEM\CurrentControlSet\Services\mppdsm Comments: This setting only applies to MSCS cluster configurations. |

Brocade Fibre Channel HBA Settings for Windows

| Component | Setting Changes |
|---|--|
| Brocade Fibre Channel HBA settings for the Windows Server 2008 OS | Setting name: path_tov Default value: 0x1E Recommended value: 0xA Comments: Use the Brocade BCU command line application to change the setting location. |
| Brocade Fibre Channel HBA settings for the Windows Server 2003 OS | Setting name: path_tov Default value: 0x1E Recommended value: 0x3C Comments: Use the Brocade BCU command line application to change the setting location. |

Emulex Fibre Channel HBA Settings for Windows

| Component | Setting Changes |
|--|---|
| Emulex Fibre Channel HBA settings for the Windows Server 2008 OS | Setting name: LinkTimeOut Default value: 0x1E Recommended value: 0xA Comments: Use the Emulex HBAnywhere application to change the setting location. |
| | Setting name: NodeTimeOut Default value: 0x1E Recommended value: 0xA Comments: Use the Emulex HBAnywhere application to change the setting location. |
| Emulex Fibre Channel HBA settings for the Windows Server 2003 OS | Setting name: LinkTimeOut Default value: 30 Recommended value: 60 |
| | Setting name: NodeTimeOut Default value: 0x1E Recommended value: 0x3C |

QLogic HBA Settings for Windows

| Component | Setting Changes |
|--|---|
| Windows Server 2008 OS Fibre Channel Qlogic settings | Setting name: ExecutionThrottle Default value: 8 Recommended value: 255 Comments: Use the QLogic SANsurfer application to change the setting location. |
| | Setting name: LinkDownTimeOut Default value: 30 Recommended value: 10 Comments: Use the QLogic SANsurfer application to change the setting location. |
| | Setting name: LunsPerTarget Default value: 8 |

| Component | Setting Changes |
|---|--|
| | <p>Recommended value: 0 Comments: Use the QLogic SANsurfer application to change the setting location.</p> <p>Setting name: PortDownRetryCount Default value: 30 Recommended value: 10 Comments: Use the QLogic SANsurfer application to change the setting location.</p> |
| <p>Windows Server 2003 OS Fibre Channel Emulex settings</p> | <p>Setting name: ExecutionThrottle Default value: 8 Recommended value: 255 Comments: Use the Emulex HBAnywhere application to change the setting location.</p> <p>Setting name: LinkDownTimeOut Default value: 30 Recommended value: 60 Comments: Use the Emulex HBAnywhere application to change the setting location.</p> <p>Setting name: LoginRetryCount Default value: 8 Recommended value: 30 Comments: Use the Emulex HBAnywhere application to change the setting location.</p> <p>Setting name: LunsPerTarget Default value: 8 Recommended value: 0</p> |

| Component | Setting Changes |
|-----------|---|
| | Comments: Use the Emulex HBAnywhere application to change the setting location. |
| | Setting name: PortDownRetryCount Default value: 30 Recommended value: 70 Comments: Use the Emulex HBAnywhere application to change the setting location. |

iSCSI HBA Settings for the Windows OS

| Component | Setting Changes |
|------------------------|---|
| Windows Server 2008 OS | Setting name: LinkDownTime Default value: 0x3C Recommended value: 0x1E Setting location: HKEY_LOCAL_MACHINE\SYSTEM\CurrentControlSet\Control\Class\{4D36E97B-E325-11CE-BFC1-08002BE10318}\XXX\parameters, where XXX is the only expandable folder. |
| Windows Server 2003 OS | Setting name: LinkDownTime Default value: 0x3C Recommended value: 0x90 Setting location: HKEY_LOCAL_MACHINE\SYSTEM\CurrentControlSet\Control\Class\{4D36E97B-E325-11CE-BFC1-08002BE10318}\XXX\parameters, where XXX is the only expandable folder. |

Things to Know – Changing the SAS Host Adapters

Use the following table to see the changes required by the SAS HBA settings.

SAS HBA Setting Changes

| Component | Setting Changes |
|--|--|
| | For the Windows Server 2008 OS and the Linux OS using DMMP failover drivers, obtain the latest LSI SAS HBA firmware required settings from http://kb.lsi.com/DownloadsCategory339.aspx . |
| | For the Windows Server 2003 OS and the Linux OS using MPP failover drivers, obtain the latest LSI SAS HBA firmware required settings from http://kb.lsi.com/DownloadsCategory339.aspx . 1. Load the HBA firmware. 2. Change the settings that follow through the HBA BIOS. |
| SAS HBA settings for both the Windows 2003 | Setting name: IODeviceMissingDelay Default value: 5 (the new default value with the customer firmware) Recommended value: 8 Comments: Use the HBA BIOS to change the setting location. |

| Component | Setting Changes |
|--|--|
| OS and the Linux OSs with MPP failover drivers | Setting name: ReportDeviceMissingDelay Default value: 10 (the new default value with the customer firmware) Recommended value: 144 Comments: Use the HBA BIOS to change the setting location. |

Things to Know – Changing the VMware OS HBA Settings

Use the following table to determine the changes required by the HBA settings when running on the VMware OS.

QLogic FC HBA Settings on the VMware OS

| Component | Setting Changes |
|--------------------------------|---|
| QLogic FC host adapter changes | Setting name: qlink_down_timeout Default value: 30 Recommended value: 10 Comments: Change this setting through the QLogic SANsurfer application. |
| | Setting name: qlport_down_retry Default value: 15 Recommended value: 5 Comments: Change this setting through the QLogic SANsurfer application. |

SAS HBA Changes for the VMware OS

| Component | Setting Changes |
|--|---|
| You can obtain LSI SAS HBA firmware required settings from http://kb.lsi.com/DownloadsCategory339.aspx . | |
| NOTE Make sure you load the HBA firmware first, then access the HBA BIOS to change the following settings. | |
| SAS host adapter changes | Setting name: IODeviceMissingDelay Default value: 5 (new default with custom firmware) Recommended value: 0 Setting locations: You can alter the setting location in the HBA BIOS. |
| | Setting name: ReportDeviceMissingDelay Default value: 10 (new default with custom firmware) |

| Component | Setting Changes |
|-----------|--|
| | Recommended value: 0 Setting locations: You can alter the setting location in the HBA BIOS. |

iSCSI Host Adapter Changes for the VMware OS

| Setting Changes |
|--|
| Setting name: <code>noop_out_interval</code> Default value: 40 Recommended value: 15 Setting locations: <code>vmkiscsi-tool -W -a "noop_out_interval=15" vmhba#</code> (where # is the iSCSI adapter number) |
| Setting name: <code>noop_out_timeout</code> Recommended value: 10 Setting locations: <code>vmkiscsi-tool -W -a "noop_out_timeout=10" vmhba#</code> (where # is the iSCSI adapter number) |

Things to Know – Changing the HP-UX OS for HBAs

Use the following table to determine the changes required by the HP-UX OS for the use of HBAs.



NOTE Make sure you make these changes after LUNs are visible to the OS.

HP-UX OS Changes for HBA

| Setting Changes |
|--|
| Setting name: <code>Disk Timeout Value</code> Default value: 30 Recommended value: 120 Setting locations: <ul style="list-style-type: none"> ▪ For the HP-UX 11iv2 OS and previous versions that use legacy device node – <code>#pvchange-t120/dev/dsk/c6t0d0</code> ▪ For the HP-UX 11iv3 OS that uses the persistent DSF device node – <code>#pvchange-t120/dev/disk/disk_number</code> |
| Setting name: <code>IO Timeout Value</code> Recommended value: 240 Setting location: <code>#lvchange -t 240/dev/vg01/lvol1.</code> |

Step 5 – Starting SANtricity ES Storage Manager

For Additional Information

For information about specific topics related to the SANtricity ES Storage Manager, refer to the following resources:

- *SANtricity ES Storage Manager Concepts for Version 10.80* electronic document topics or to the PDF on the SANtricity ES Storage Manager Installation DVD.
- Online help topics in the Enterprise Management Window and the Array Management Window in SANtricity ES Storage Manager.

Procedure – Starting SANtricity ES Storage Manager

1. At the prompt, type `SMclient`, and press Enter.
2. Do the storage arrays appear in the Enterprise Management Window?
 - **Yes** – You are finished with this procedure.
 - **No** – A dialog asks whether to add the storage arrays automatically or manually. For the steps to add the storage arrays, see “[Step 6 – Adding the Storage Array.](#)”



NOTE The Enterprise Management Window and the Array Management Window are the two main windows that you use to manage your storage array. The title at the top of each window identifies its type.

Things to Know – Enterprise Management Window and Array Management Window

Overview of the Enterprise Management Window and the Array Management Window

| User Interface | Description |
|------------------------------|---|
| Enterprise Management Window | <p>It is the main window that you see when you first start SANtricity ES Storage Manager.</p> <p>It provides you with a view of all of the storage arrays, including the partially managed storage arrays, in your management domain.</p> <p>It allows you to automatically or manually add and remove storage arrays, set alert notifications (email and SNMP), and perform other high-level configuration functions.</p> <p>It provides a high-level status of the health of each storage array.</p> <p>It allows you to manage and configure an individual storage array by launching the Array Management Window.</p> |
| Array Management Window | <p>It provides you with all of the functions to configure, maintain, and troubleshoot an individual storage array.</p> <p>You launch the Array Management Window from the Enterprise Management Window to manage an individual storage array.</p> <p>Multiple Array Management Windows can appear at the same time (one for each storage array you want to manage).</p> |

| User Interface | Description |
|--|--|
| Enterprise Management Window Setup Tab and Array Management Window Setup Tab | When you first start either the Enterprise Management Window or the Array Management Window, a Setup tab is selected by default. The Setup tab provides quick access to common setup tasks. The tasks shown are different, depending on the window from which the Setup tab was launched. |

Enterprise Management Window with the Setup Tab Selected

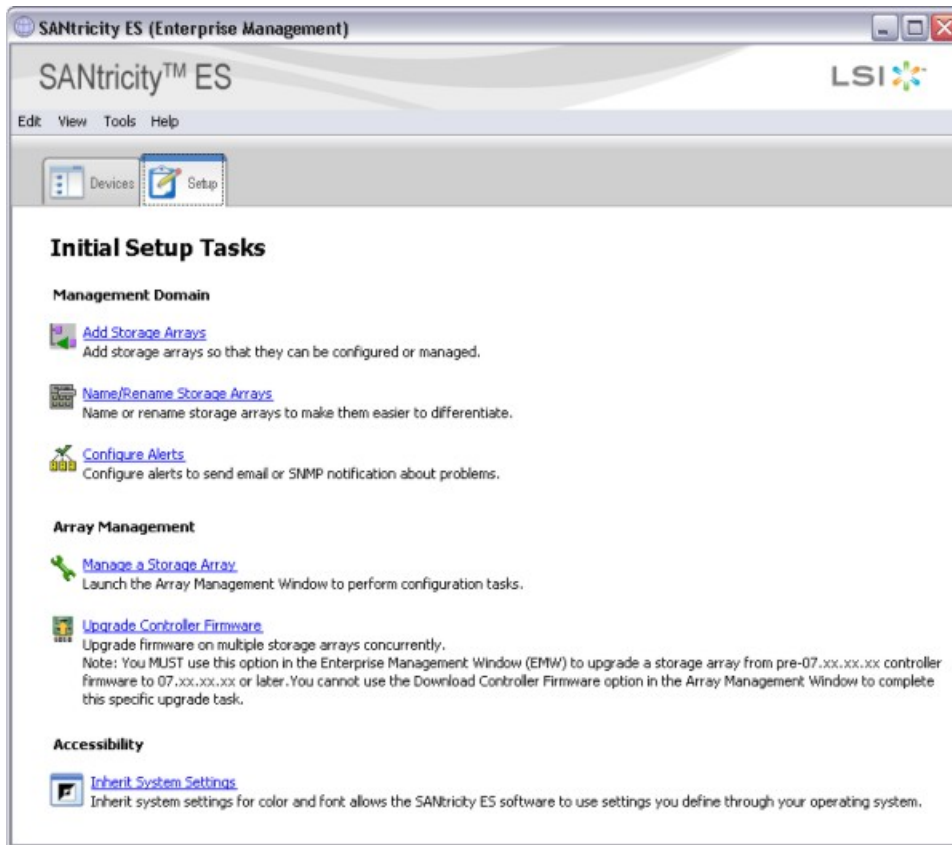

82005-01

Array Management Window with the Setup Tab Selected

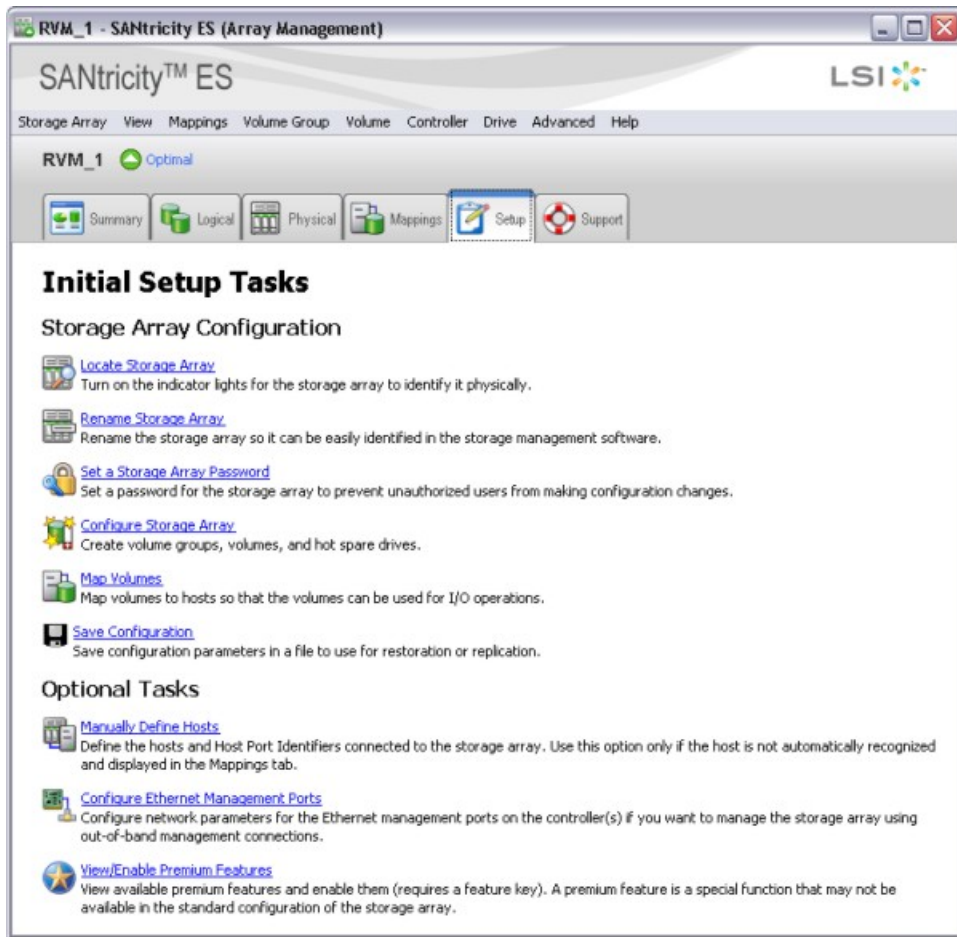

The screenshot shows the SANtricity ES Array Management interface. The window title is "RVM_1 - SANtricity ES (Array Management)". The main header displays "SANtricity™ ES" and the LSI logo. A menu bar includes "Storage Array", "View", "Mappings", "Volume Group", "Volume", "Controller", "Drive", "Advanced", and "Help". Below the menu bar, the status "RVM_1" is shown with a green "Optimal" indicator. A navigation bar contains icons for "Summary", "Logical", "Physical", "Mappings", "Setup" (which is highlighted with a dashed border), and "Support".

Initial Setup Tasks

Storage Array Configuration

- [Locate Storage Array](#)
Turn on the indicator lights for the storage array to identify it physically.
- [Rename Storage Array](#)
Rename the storage array so it can be easily identified in the storage management software.
- [Set a Storage Array Password](#)
Set a password for the storage array to prevent unauthorized users from making configuration changes.
- [Configure Storage Array](#)
Create volume groups, volumes, and hot spare drives.
- [Map Volumes](#)
Map volumes to hosts so that the volumes can be used for I/O operations.
- [Save Configuration](#)
Save configuration parameters in a file to use for restoration or replication.

Optional Tasks

- [Manually Define Hosts](#)
Define the hosts and Host Port Identifiers connected to the storage array. Use this option only if the host is not automatically recognized and displayed in the Mappings tab.
- [Configure Ethernet Management Ports](#)
Configure network parameters for the Ethernet management ports on the controller(s) if you want to manage the storage array using out-of-band management connections.
- [View/Enable Premium Features](#)
View available premium features and enable them (requires a feature key). A premium feature is a special function that may not be available in the standard configuration of the storage array.

82005-00

Step 6 – Adding the Storage Array

Things to Know – Storage Array

- Make sure that you have connected all of the applicable cables.
- Make sure that you have turned on the power to the storage array (attached drive trays first, and then the controller-drive tray or controller tray).
- Make sure that you have installed the applicable storage management software.

Procedure – Automatically Adding a Storage Array

1. From the Enterprise Management Window, select **Tools** > **Automatic Discovery**.
2. In the confirmation dialog, click **OK** to start the automatic discovery.
This process finds all of the storage arrays on the local sub-network. Several minutes might elapse to complete the process.
3. Do you see the storage array in the **Devices** tab of the Enterprise Management Window?
 - **Yes** – Go to [Step 7 – Naming the Storage Array](#).
 - **No** – Go to [Procedure – Manually Adding a Storage Array](#) (the storage array might reside outside the local sub-network).



NOTE After adding the storage array, you can view or change the cache memory settings of the storage array. See [Step 14 – Changing the Cache Memory Settings](#).

Procedure – Manually Adding a Storage Array

1. From the Enterprise Management Window, click the **Add Storage Arrays** link.
The **Add New Storage Array – Manual** dialog appears. By default, the **Out-of-band management** radio button is selected.

Add New Storage Array – Manual Dialog

82004-03

2. Select one of the following radio buttons, depending on the type of management you are using:
 - Out-of-band – Select the **Out-of-band management** radio button.
 - In-band – Select the **In-band management** radio button.
3. Manually enter the host names or the IP addresses of the controllers (out-of-band management method) or the host name or IP address of the host that is running the host-agent software (in-band management method), and click **Add**.

The storage array appears in the Enterprise Management Window.



NOTE You can enter the IP addresses in either the IPv4 format or the IPv6 format.



NOTE After adding the storage array, you can view or change the cache memory settings of the storage array. See [Step 14 – Changing the Cache Memory Settings](#).

Things to Know – Rescanning the Host for a New Storage Array

You can rescan your host to perform these actions:

- Add new storage arrays that are connected to the host but are not shown in the Enterprise Management Window.
- Check the current status of storage arrays that are connected to the host.

 **NOTE** When you rescan your host for new storage arrays, you must stop and restart the host agent before selecting the rescan option.

Procedure – Rescanning the Host for a New Storage Array

1. From the **Devices** tab in the Enterprise Management Window, select the host that you want to rescan.

 **NOTE** If automatic discovery, rescan, add, or remove operations are in progress, you cannot rescan for a storage array.

2. Select **Tools > Rescan**.
3. In the confirmation dialog, click **OK** to start scanning the selected host for storage arrays.

This process adds new storage arrays and updates the status of the old storage arrays that are connected to the selected host. Several minutes might elapse to complete the process.

Step 7 – Naming the Storage Array

Things to Know – Naming the Storage Array

- A storage array name can consist of letters, numbers, and the special characters underscore (_), hyphen (-), and pound sign (#). No other special characters are permitted.
- When you have named a storage array, the prefix "Storage Array" is automatically added to the name. For example, if you named the storage array "Engineering," it appears as "Storage Array Engineering."
- When you first discover a storage array or manually add it, the storage array will have a default name of "unnamed."

Procedure – Naming a Storage Array

1. From the **Setup** tab on the Enterprise Management Window, click **Name/Rename Storage Arrays**.
The **Name/Rename** dialog appears.
2. Perform one of these actions, depending on the number of unnamed storage arrays:
 - **More than one storage array is unnamed** – Go to step 3.
 - **One storage array is unnamed** – Go to step 6.
3. Select one of the unnamed storage arrays, and then select **Tools > Locate Storage Array**.
4. Find the physical storage array to make sure that you correlated it to the particular storage array listed.
5. Repeat step 3 through step 4 for each unnamed storage array.
6. Select an unnamed storage array in the top portion of the dialog.
The current name and any comment for the storage array appear at the bottom of the dialog.
7. Change the name of the storage array, add a comment (such as its location), and click **OK**.
The **Warning** dialog appears.
8. Perform one of these actions:
 - **The host is not running any path failover drivers** – Click **Yes** to change the name of the storage array. Go to step 9.
 - **The host is running a path failover driver** – Click **No**. Go to step 9.
9. Do you need to name other storage arrays?
 - **Yes** – Click **Apply** to make the change and to keep the dialog open. Go to step 3.
 - **No** – Click **OK** to make the change and to close the dialog.

Step 8 – Resolving Problems

If you noted any amber LEDs during Turning on the Power and Checking for Problems in the hardware installation documents, the Enterprise Management Window should show a corresponding indication.

Procedure – Resolving Problems

1. Click the **Devices** tab of the Enterprise Management Window to check the status of the storage arrays.
2. Double-click the storage array with the Needs Attention condition.
The associated Array Management Window (AMW) is launched.
3. Click the **Physical** tab of the AMW to see the configuration.
4. Perform one of these actions, depending on the status shown:
 - **Optimal** – No problems need to be resolved. Go to [Step 9 – Adding Controller Information for the Partially Managed Storage Array](#).
 - **Needs Attention** – Go to step 5.
 - **Unresponsive** – Refer to the online help topics in the Enterprise Management Window for the procedure.
5. Select **Storage Array**, and click **Recovery Guru** to launch the Recovery Guru. Follow the steps in the Recovery Guru.

Retrieving Trace Buffers

Use the **Advanced >>Troubleshooting >> Support Data >> Retrieve Trace Buffers** option to save trace information to a compressed file. The firmware uses the trace buffers to record processing, including exception conditions, that might be useful for debugging. Trace information is stored in the current buffer. You have the option to move the trace information to the flushed buffer after you retrieve the information. (The option to move the trace information to the flushed buffer is not available if you select **Flushed buffer** from the **Trace Buffers** list.) Because each controller has its own buffer, there might be more than one flushed buffer. You can retrieve trace buffers without interrupting the operation of the storage array and with minimal effect on performance.



NOTE Use this option only under the guidance of your Customer and Technical Support representative.

A zip-compressed archive file is stored at the location you specify on the host. The archive contains trace files from one or both of the controllers in the storage array along with a descriptor file named `trace_description.xml`. Each trace file includes a header that identifies the file format to the analysis software used by the Customer and Technical Support representative. The descriptor file has the following information:

- The World Wide Identifier (WWID) for the storage array.
- The serial number of each controller.
- A time stamp.
- The version number for the controller firmware.
- The version number for the management application programming interface (API).
- The model ID for the controller board.
- The collection status (success or failure) for each controller. (If the status is Failed, the reason for failure is noted, and no trace file exists for the failed controller.)

1. From the Array Management Window, select **Advanced > Troubleshooting > Support Data > Retrieve Trace Buffers**.
2. Select the **Controller A** check box, the **Controller B** check box, or both check boxes.
If the controller status message to the right of a check box is **Failed** or **Disabled**, the check box is disabled.
3. From the **Trace Buffers** drop-down list, select **Current buffer**, **Flushed buffer**, **Current and flushed buffers**, or **Current, flushed, and platform buffers**.
4. If you choose to move the buffer, select the **Move current trace buffer to the flushed buffer after retrieval** option.
The **Move current trace buffer to the flushed buffer after retrieval** option is not available if you selected **Flushed buffer** in step 3.
5. In the **Specify filename** text box, either enter a name for the file to be saved (for example, C:\filename.zip), or browse to a previously saved file if you want to overwrite that file.
6. Click **Start**.
The trace buffer information is archived to the file that you specified in step 5. If you click **Cancel** while the retrieval process is in progress, and then click **OK** in the cancellation dialog that appears, the trace buffer information is not archived, and the **Retrieve Trace Buffers** dialog remains open.
7. When the retrieval process is finished, the label on the **Cancel** button changes to **Close**. Choose one of the following options:
 - To retrieve trace buffers again using different parameters, repeat step 2 through step 6.
 - To close the dialog and return to the Array Management Window, click **Close**.

Step 9 – Adding Controller Information for the Partially Managed Storage Array



NOTE You only need to perform this step if you have partially managed storage arrays.

Key Terms

partially managed storage array

A condition that occurs when only one controller is defined or can be reached when the storage array is added to or found by the storage management software. In this case, volume management operations can be done only on volumes owned by the reachable controller. Many other management operations that require access to both controllers are not available.

Things to Know – Partially Managed Storage Arrays

You can identify a storage array as a partially managed storage array if you see these indications for the storage array:

- When you close the **Add New Storage Array – Manual** dialog after adding the storage array, a **Partially Managed Storage Arrays** dialog appears.
 - When you try to manage the storage array using the Array Management Window, a **Partially Managed Storage Arrays** dialog appears.
 - When you select **View > Partially Managed Storage Arrays**, the storage array is listed in the **Partially Managed Storage Arrays** dialog.
 - When you place the cursor on the storage array, “partially managed” appears in the tooltip.
-



NOTE The tooltip indication appears only for out-of-band storage arrays.

Procedure – Automatically Adding a Partially Managed Storage Array



NOTE These steps are for out-of-band partially managed storage arrays only. For in-band partially managed storage arrays, verify the connection, and perform the steps in [Procedure – Rescanning the Host for a New Storage Array](#) to rescan the host.

1. From the Enterprise Management Window, select **View > Partially Managed Storage Arrays**.
2. Select the required partially managed storage array from the list of storage arrays.
3. Click **Add More** to add the information about the second controller.
The **Add New Storage Array – Manual** dialog appears.
4. Manually enter the host names or the IP addresses of the controllers (out-of-band management method) or the host name or IP address of the host running the host-agent software (in-band management method), and click **Add**.

The storage array appears in the Enterprise Management Window.



NOTE You can enter IP addresses in either the IPv4 format or the IPv6 format.



NOTE After adding the storage array, you can view or change the cache memory settings of the storage array. See [Step 14 – Changing the Cache Memory Settings](#).

Step 10 – Manually Configuring the Controllers

This topic describes how you can manually configure the controllers in the storage array for out-of-band management.

Things to Know – Manually Configuring the Controllers

 **NOTE** You need to perform this step only if you want to use the out-of-band management method *and* you do not have a DHCP server to automatically assign IP addresses for the controllers.

- See [Step 1 – Deciding on the Management Method](#) to determine if you need to make any configuration changes to the controller.
- In general, Ethernet port 1 on each controller is used for storage management, and Ethernet port 2 on each controller is used by the Customer and Technical Support representative.
- You should configure Ethernet port 2 only if your Customer and Technical Support representative asks you to do so.
- You can configure a gateway on only one of the Ethernet ports on each controller.
- Ethernet port 1 and Ethernet port 2 must be on different sub-networks.
- You can select one of the following speed and duplex mode combinations for your Ethernet ports. If you select the auto-negotiate option, the controller will use the highest speed supported by the Ethernet connection.

Supported Speed and Duplex Mode Combinations

| Speed | Duplex Mode |
|----------------|-------------|
| 1000BASE-T | Duplex |
| 1000BASE-T | Half-Duplex |
| 100BASE-T | Duplex |
| 100BASE-T | Half-Duplex |
| 10BASE-T | Duplex |
| 10BASE-T | Half-Duplex |
| Auto-negotiate | |

 **NOTE** Your controller might not support some of the speed and duplex mode combinations. You can see the list of speed and duplex mode combinations that are supported on your controller when you change your network configuration. (For the procedure to change your network configuration, see [Procedure – Configuring the Controllers](#).)

Things to Know – Options for Manually Configuring the Controllers

If you will use the out-of-band method and do not have a DHCP server, you have two options for manually configuring your controllers.

Option 1 – Use the In-Band Management Method Initially (Recommended)

This option requires that you install the host-agent software on one of the hosts that is attached to the storage array and then use the in-band management method to initially discover the storage array and to manually configure the controllers.

To discover the storage array and to manually configure the controllers, perform the procedure in [Procedure – Configuring the Controllers](#).

Option 2 – Set Up a Private Network

 **NOTE** This option is recommended only if the host on which you will use the in-band management method does not support the host-agent software.

This option requires that you install the storage management software on a management station (such as a laptop computer) and then set up a private network to initially discover the storage array and manually configure the controllers.

You can either connect your management station directly into Ethernet port 1 on each controller or use a hub (Ethernet switches or routers are not permitted).

To configure the management station, perform the procedure in [Procedure – Configuring the Management Station](#).

 **NOTE** If you connect the management station directly to the Ethernet ports on the controller-drive tray other than a CE5400 controller-drive tray, you must use an Ethernet crossover cable. The Ethernet crossover cable is a special cable that reverses the pin contacts between the two ends of the cable.

 **NOTE** The CE5400 controller-drive trays use Auto-MDIX (automatic medium-dependent interface crossover) technology to detect the cable type and configure the connection to the management station accordingly.

Procedure – Configuring the Management Station

1. Change the IP address on the TCP/IP port on the management station from an automatic assignment to a manual assignment by using the default IP address subnet of the controllers.
 - Make note of the current IP address of the management station so that you can revert back to it after you have completed the procedure.
 - You must set the IP address for the management station to something other than the controller IP addresses (for example, use 192.168.128.100 for an IPv4 network, or use FE80:0000:0000:0000:02A0:B8FF:FE29:1D7C for an IPv6 network).

 **NOTE** In an IPv4 network, the default IP addresses for Ethernet port 1 on controller A and controller B are 192.168.128.101 and 192.168.128.102, respectively.

- If your network is an IPv4 network, check the subnet mask to verify that it is set to 255.255.255.0, which is the default setting.
 - Refer to your operating system documentation for instructions about how to change the network settings on the management station and how to verify that the address has changed.
2. After you have configured your management station, perform the procedure in [Procedure – Configuring the Controllers](#).

Procedure – Configuring the Controllers

1. In the **Devices** tab on the Enterprise Management Window, double-click the storage array for which you want to configure the controller network settings.

The associated Array Management Window is launched.

2. Click the **Physical** tab.
3. Highlight controller A in the Physical pane of the Array Management Window, and select **Controller > Configure > Ethernet Management Ports**.

Change Network Configuration Dialog with IPv4 Settings

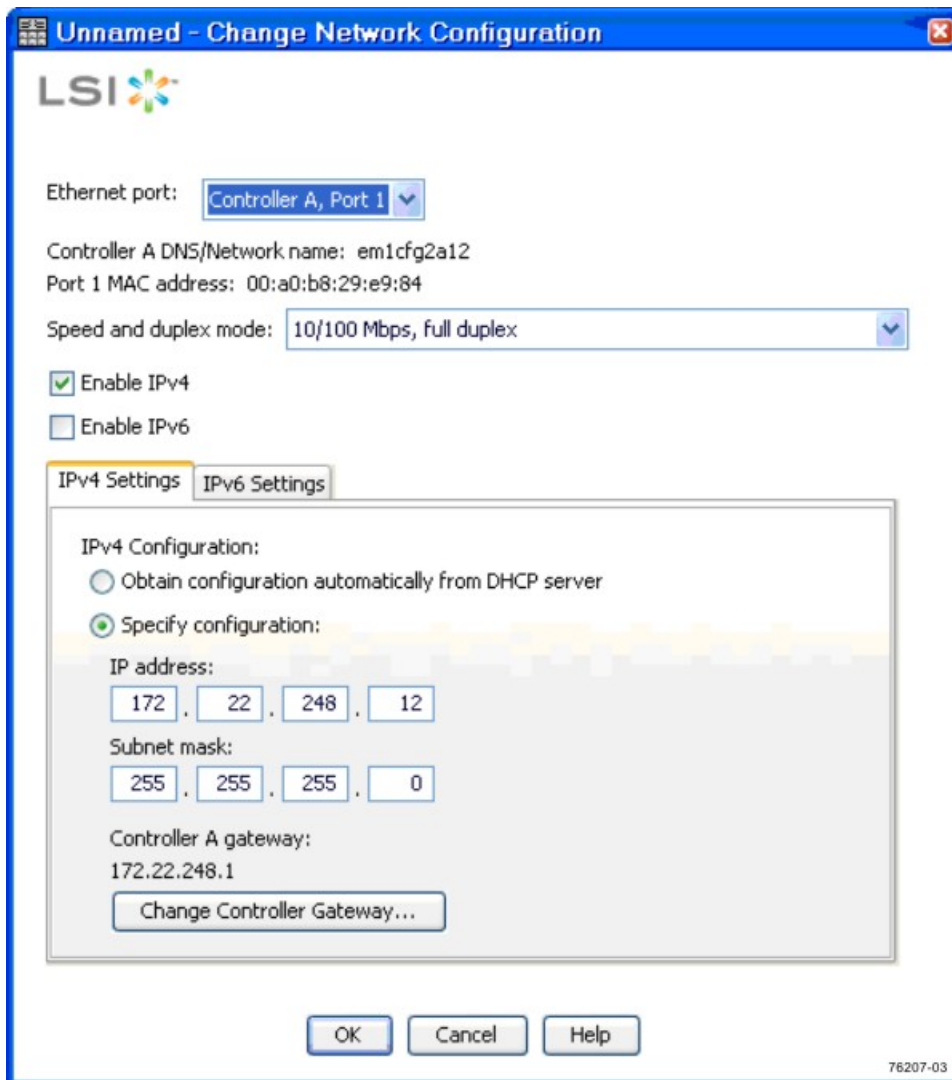

The screenshot shows a dialog box titled "Unnamed - Change Network Configuration" with the LSI logo. The "Ethernet port" is set to "Controller A, Port 1". The "Controller A DNS/Network name" is "em1cfg2a12" and the "Port 1 MAC address" is "00:a0:b8:29:e9:84". The "Speed and duplex mode" is "10/100 Mbps, full duplex". The "Enable IPv4" checkbox is checked, and "Enable IPv6" is unchecked. The "IPv4 Settings" tab is active, showing "IPv4 Configuration" with "Obtain configuration automatically from DHCP server" unselected and "Specify configuration:" selected. The "IP address" is "172.22.248.12", the "Subnet mask" is "255.255.255.0", and the "Controller A gateway" is "172.22.248.1". There is a "Change Controller Gateway..." button. At the bottom are "OK", "Cancel", and "Help" buttons. The version number "76207-03" is in the bottom right corner.

Change Network Configuration Dialog with IPv6 Settings

4. Select **Controller A, Port 1** in the **Ethernet port** drop-down list.
5. From the **Speed and duplex mode** drop-down list, select **Auto-negotiate**.



ATTENTION Possible connectivity issues – After you select Auto-negotiate, make sure that your Ethernet switch also is set to **Auto-negotiate**. Connectivity issues might occur if **Auto-negotiate** is not selected in SANtricity ES Storage Manager and is not set for the Ethernet switch.

6. Depending on the format of your network configuration information, select the **Enable IPv4** check box, the **Enable IPv6** check box, or both check boxes.
7. Depending on the format that you have selected, enter the network configuration information (IP address, subnet mask, and gateway or IP address and routable IP address) in the **IPv4 Settings** tab or the **IPv6 Settings** tab.



NOTE You must obtain the network configuration information from your network administrator.

8. Select **Controller B, Port 1** in the **Ethernet port** drop-down list, and repeat step 5 through step 7 for controller B.

9. Click **OK**.
10. If you are manually configuring the controllers using a private network, perform these actions after configuring the controllers:
 - a. Disconnect the Ethernet cable from your management station, and reconnect the Ethernet cables from the controllers into your regular network.
 - b. Complete the steps necessary to change the management station's IP address back to what it was originally.

Step 11 – Setting a Password

Things to Know – Passwords

- You need to set a password for your storage array to protect it from serious damage, such as security breaches.
- When you set a password, only authorized personnel are allowed to run the commands that change the state of the storage array, such as commands to create volumes and the commands to modify the cache settings.
- For increased protection, use a long password with at least 15 alphanumeric characters. The maximum password length is 30 characters.
- Passwords are case sensitive.
- You will be asked for a password only when you *first* attempt to change the configuration (such as creating a volume) or when you *first* perform a destructive operation (such as deleting a volume). You must exit both the Array Management Window and the Enterprise Management Window to be asked for the password again.
- Any type of view operation does not require a password at any time.
- If you no longer want to have the storage array password-protected, enter the current password, and then leave the **New password** text box and the **Confirm password** text box blank.



NOTE The storage array password is different from the pass phrase used for SafeStore Drive Security.



NOTE If you forget your password, you must contact your Customer and Technical Support representative for help to reset it.

Procedure – Setting a Password

1. From the **Setup** tab on the Enterprise Management Window, click **Manage a Storage Array**.
The Select Storage Array dialog appears.
2. Highlight the storage array for which you want to set a password, and click **OK**.
The associated Array Management Window is launched.
3. From the **Setup** tab on the Array Management Window, click **Set a Storage Array Password**.
4. Follow the on-screen instructions. Click **Help** for more information.
5. Click **OK**.

Step 12 – Removing a Storage Array

Things to Know – Removing Storage Arrays

- When you remove a storage array, multiple storage arrays, or a host, they are removed from the Enterprise Management Window of your storage management station. They can be viewed from other storage management stations.
- You can delete the storage arrays and hosts from the Tree view or the Table view. These views are located on the **Devices** tab on the Enterprise Management Window. However, you can delete only one storage array at a time from the Tree view.

Procedure – Removing a Storage Array

Use these steps to remove a storage array, multiple storage arrays, or a host to which multiple storage arrays are connected.

1. From the Tree view or the Table view in the Enterprise Management Window **Devices** tab, select the storage array, the storage arrays, or the host that you want to remove.



NOTE Before you try to remove a storage array, multiple storage arrays, or a host, you must close all of the Array Management Windows and the **Script Editor** dialogs that are associated with the selected storage arrays. If the Array Management Window or the **Script Editor** dialog is open for a storage array, that storage array is not removed. All of the other storage arrays are removed.

2. Select **Edit > Remove**.
3. In the confirmation dialog, click **Yes** to remove the storage array.



NOTE While removing multiple storage arrays, multiple confirmation dialogs, one for each storage array, appear.

Depending on what you have selected to be removed, one of these actions occurs:

- If you have selected a storage array, the storage array is removed from the Enterprise Management Window.
- If you have selected multiple storage arrays, the storage arrays are removed from the Enterprise Management Window.
- If you have selected a host, the host and its associated storage arrays are removed from the Enterprise Management Window.

Step 13 – Configuring Email Alerts and SNMP Alerts

This topic describes how you can make sure that SANtricity ES Storage Manager sends critical issues with the storage array to the correct email address.

Key Terms

Management Information Base (MIB)

CONTEXT [Management] The specification and formal description of a set of objects and variables that can be read and possibly written using the Simple Network Management Protocol (SNMP). (The Dictionary of Storage Networking Terminology, 2004)

Simple Network Management Protocol (SNMP)

CONTEXT [Network] [Standards] An IETF protocol for monitoring and managing systems and devices in a network. The data being monitored and managed is defined by a Management Information Base (MIB). The functions supported by the protocol are the request and retrieval of data, the setting or writing of data, and traps that signal the occurrence of events. (The Dictionary of Storage Networking Terminology)

Things to Know – Alert Notifications

- Setting alert destinations lets you specify addresses for the delivery of email messages and SNMP trap messages whenever a critical problem exists with the storage array.
- You must have the Event Monitor running on a machine (a management station or a host) to receive alerts. The machine should be one that runs continuously.



NOTE If you choose not to automatically enable the event monitor during installation, you do not receive critical alert notifications.

Procedure – Setting Alert Notifications

1. From the **Setup** tab on the Enterprise Management Window, click **Configure Alerts**.
The **Select Storage Array** dialog appears.
2. Indicate on which storage arrays you want the alerts to be set, and click **OK**.
 - If you selected the **All Storage Arrays** choice, the main **Alerts** dialog appears.
 - If you selected the **Individual Storage Array** choice, you must first select the specific storage array and click **OK** before the main **Alerts** dialog appears.
 - If you selected the **Specific Host** choice, you must first select a host and click **OK** before the main **Alerts** dialog appears.
3. Specify the alerts that you want by using the tabs on the dialog. Use this information, and click **OK** when you are finished setting the alerts.

Mail Server Tab

- You must specify a mail server and an email sender address if you want to set email alerts. The mail server and sender address are not required if you are setting SNMP alerts.
- The Sender Contact Information is optional. Include the information if you plan to send alerts to your Customer and Technical Support representative; otherwise, delete the fields.

Email Tab

- Enter the email addresses in standard format, such as xxx@company.com.

- If one of the email alerts that you configure is for your Customer and Technical Support representative, make sure that you select the **Event + Profile** or **Event + Support** choice in the Information to Send column. This additional information aids in troubleshooting your storage array. The **Event + Support** choice includes the profile.

SNMP Tab

- To set up alert notifications using SNMP traps, you must copy and compile a Management Information Base (MIB) file on the designated network management station.
- The SNMP trap destination is the IP address or the host name of a station running an SNMP service. At a minimum, this destination will be the network management station.

Step 14 – Changing the Cache Memory Settings

This topic provides information about modifying cache memory settings in your storage array through the SANtricity ES Storage Manager to enhance system performance.

Key Terms

cache memory

An area of random access memory (RAM) on the controller. This memory is dedicated to collecting and holding related data until a drive tray or a storage tray is ready to process the data. Cache memory has a faster access time than the actual drive media.

Things to Know – Cache Memory Settings

- If the data requested from the host for a read exists in the cache memory from a previous operation, the drive is not accessed. The requested data is read from the cache memory.
- Write data is written initially to the cache memory. When a percentage of unwritten data is reached, the data is flushed from or written to the drives.
- During a controller failure, the data in the cache memory of the controller might be lost.
- To protect data in the cache memory, you can set a low percentage of unwritten data in the cache memory to trigger a flush to the drives. However, as the number of drive reads and drive writes increases, this setting decreases performance.
- When cache mirroring is enabled, if one controller in a controller tray or controller-drive tray fails, the second controller takes over. The surviving controller uses its mirrored version of the failed controller's cache data to continue reading from and writing to the volumes previously managed by the failed controller.

Procedure – Viewing the Cache Memory Size Information

1. From the **Setup** tab on the Enterprise Management Window, click **Manage a Storage Array**.
The **Select Storage Array** dialog appears.
2. Select the storage array that you want to manage, and click **OK**.
The associated Array Management Window is launched.
3. Click the **Physical** tab.
4. Select controller A in the Physical pane of the Array Management Window, and the **Properties** view appears in the left pane.
5. Scroll through the **Base** tab until you find the cache information and the cache backup device information.

Procedure – Changing the Cache Memory Settings

1. From the **Setup** tab on the Enterprise Management Window, click **Manage a Storage Array**.
The **Select Storage Array** dialog appears.
2. Select the storage array that you want to manage, and click **OK**.
The associated Array Management Window is launched.
3. Select **Storage Array > Change > Cache Settings**.
The associated **Change Cache Settings** dialog appears.

4. Select the percentage of unwritten data in the cache to trigger a cache flush in the **Start flushing** text box.
5. Select the percentage of unwritten data in the cache to stop a cache flush in progress in the **Stop flushing** text box.
6. Select the required cache block size, and click **OK**.

Procedure – Changing the Volume Cache Memory Settings

1. From the **Setup** tab on the Enterprise Management Window, click **Manage a Storage Array**.
The **Select Storage Array** dialog appears.
2. Select the storage array you want to manage, and click **OK**.
The associated Array Management Window is launched.
3. Select **Volume > Change > Cache Settings**.
The associated **Change Cache Settings** dialog appears.
4. To allow read operations from the host to be stored in the cache memory, select the **Enable read caching** check box.
5. To allow write operations from the host to be stored in the cache memory, select the **Enable write caching** check box.
6. Select the enable write caching options by using the information in this list:
 - **Enable write caching without batteries** – Allows data from the drives to be written to the cache memory even when the controller batteries are discharged completely, not fully charged, or not present.
 - **Enable write caching with mirroring** – Mirrors data in the cache memory across two redundant controllers that have the same cache memory size.
7. To enable copying of additional data while copying read operations data from the drives, select the **Dynamic cache read prefetch** check box.
8. Click **OK**.

Step 15 – Enabling the Premium Features



NOTE If you did not obtain any premium feature key files from your storage vendor, skip this step.

Key Terms

premium feature

A feature that is not available in the standard configuration of the storage management software.

Things to Know – Premium Features

You enable a premium feature through a feature key file that you obtain from your storage vendor. The premium feature is either enabled or disabled. When a premium feature is disabled, it does not appear in the graphical user interface (GUI).

If your system is a low-tier performance configuration and you want to upgrade to a high-tier performance configuration, use the following procedure to obtain enhanced performance.

Procedure – Enabling the Premium Features

1. From the **Setup** tab on the Enterprise Management Window, click **Manage a Storage Array**.
The **Select Storage Array** dialog appears.
2. Highlight the storage array on which you want to enable a premium feature, and click **OK**.
The associated Array Management Window appears.
3. Select **Storage Array > Premium Features**.
The associated **Premium Features and Feature Pack Information** dialog appears.
4. Select a feature from the **Premium Feature** list.
5. Click **Enable**.
The associated **Select Feature Key File** dialog appears.
6. Enter the file name of the feature key file for the particular premium feature that you want to enable.
7. Click **OK** to close the **Select Feature Key File** dialog.
The **Premium Features installed on storage array** drop-down list shows the name and the status of the premium feature that you have enabled.
8. Repeat step 4 through step 7 for each premium feature that you want to enable.

Step 16 – Defining the Hosts

 **NOTE** You must know the world wide port names of each HBA host port. If you have not already recorded them, see [Installing Host Bus Adapters](#) for your particular configuration (CE2600 Controller-Drive Tray, CE2600-60 controller-drive tray, CE4900 controller-drive tray, CE5400 controller-drive tray, or CE7900 controller tray) for instructions to obtain these world wide port names.

 **NOTE** If you will not use storage partitions or you do not have the SANshare Storage Partitioning premium feature enabled on your storage array, you can skip the information about [Things to Know – Host Groups](#) and [Things to Know – Storage Partitions](#), and go to either [Procedure – Defining the Hosts](#) or [Procedure – Defining the iSCSI Hosts](#).

Things to Know – Hosts

The host adapters in the hosts that are attached to the storage array are known to the storage management software. However, the storage management software does not know which host adapters are associated with which hosts. Use these steps to associate each host with its specific host adapters.

Things to Know – Host Groups

- A host group is a group (cluster) of two or more hosts that share access, in a storage partition, to specific volumes on the storage array. You can create an optional logical entity in the storage management software. You must create a host group only if you will use storage partitions.
- If you must define a host group, you can define it through the Define Hosts Wizard described in [Procedure – Defining the Hosts](#).

Things to Know – Storage Partitions

- A storage partition is a logical entity that consists of one or more volumes that can be accessed by a single host or can be shared among hosts that are part of a host group. You can think of a storage partition as a virtual storage array. That is, take the physical storage array and divide it up into multiple virtual storage arrays that you can then restrict to be accessible only by certain hosts.
- SANshare Storage Partitioning is a premium feature. This premium feature was either already enabled on your storage array at the factory, or you must purchase a feature key file from your storage vendor to enable it.
- You do not create storage partitions in this step, but you must understand them to define your hosts.
- You *do not* need to create storage partitions if these conditions exist (see the first image below):
 - You have only one attached host that accesses all of the volumes on the storage array.
 - You plan to have all of the attached hosts share access to all of the volumes in the storage array.

 **NOTE** All of the attached hosts must have the same operating system (homogeneous), and you must have special software on the hosts (such as clustering software) to manage volume sharing and accessibility. This qualification does not, however, exclude the use of heterogeneous hosts (see [Additional Storage Partitions Required](#)).

- You *do* need to create storage partitions if these conditions exist (see the two images that display with no partition required below):
 - You want certain hosts to access only certain volumes.
 - You have hosts with different operating systems (heterogeneous) attached in the same storage array. You must create a storage partition for each type of host.

Example of No Additional Storage Partitions Required

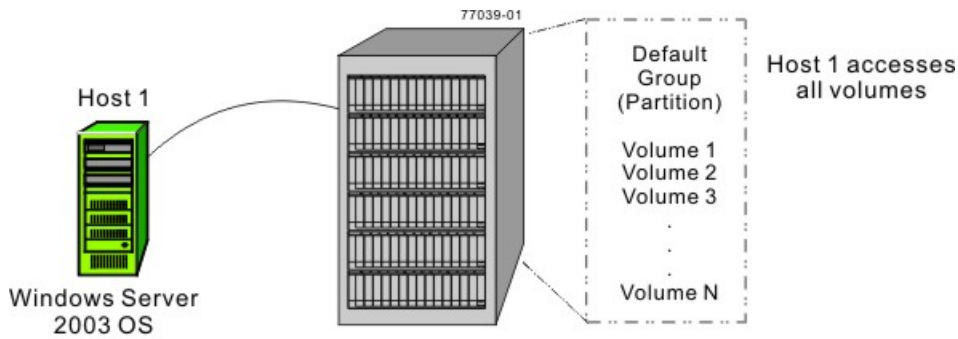

A single host accesses **all** volumes;
no additional storage partitions are needed.

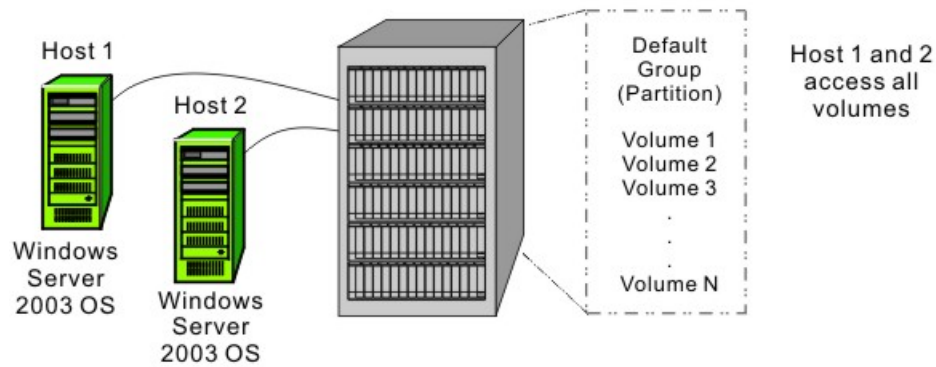

Multiple homogeneous hosts share access to **all** volumes;
no additional storage partitions are needed and
no specific host group is needed.

Example of Additional Storage Partitions Required (Homogeneous Host)

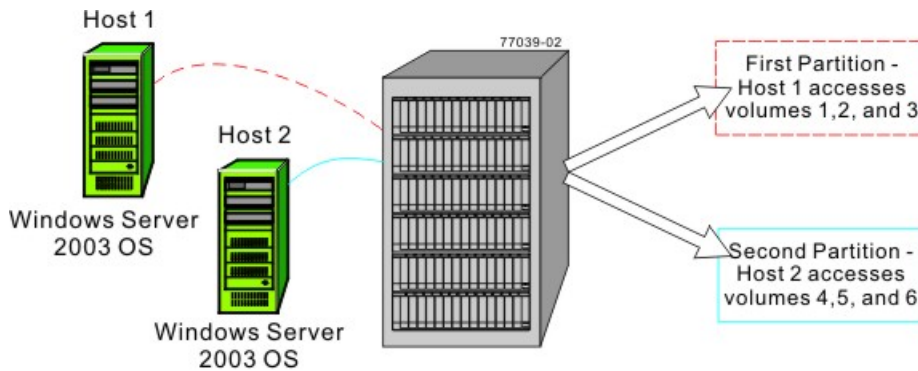

- Each host needs access to specific volumes.
- Both hosts use the same operating system (homogeneous).
- Storage divided into two logical storage partitions.
- A Default Group (partition) is not used.

Example of Additional Storage Partitions Required (Heterogeneous Hosts)

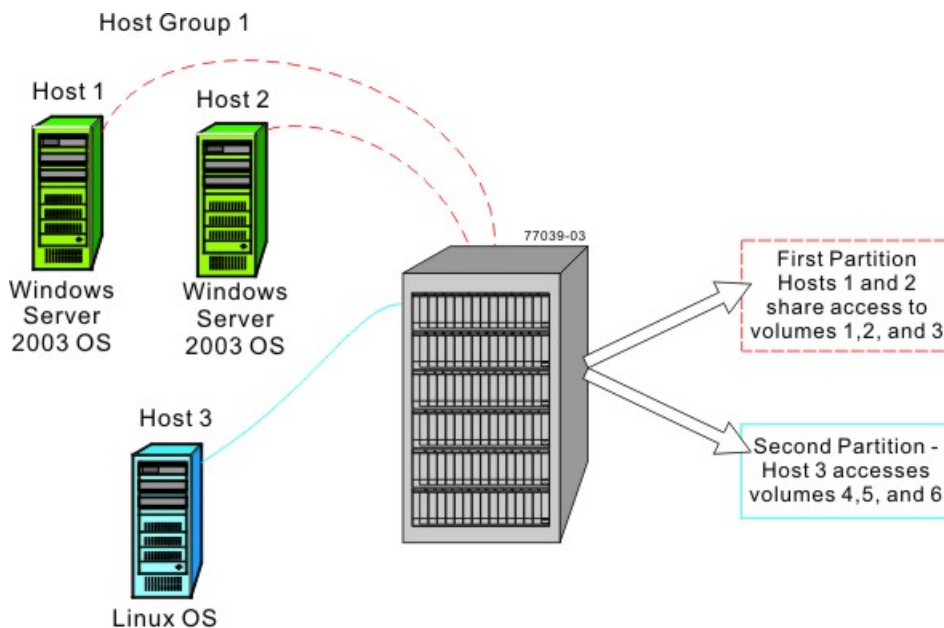

- Host 1 and host 2 (Windows Server 2003 OS) share access to specific volumes through host group 1.
- Two heterogeneous hosts (Linux OS and Windows Server 2003 OS) exist.
- Host 3 (Linux) accesses specific volumes.
- Storage is divided into two logical storage partitions.
- A Default Group (partition) is not used.

Procedure – Defining the Hosts

1. From the **Setup** tab on the Enterprise Management Window, click **Manage a Storage Array**.
The **Select Storage Array** dialog appears.
2. Highlight the storage array on which you want to define a host, and click **OK**.
The associated Array Management Window is launched.
3. From the **Setup** tab on the Array Management Window, click **Manually Define Hosts**.
4. Use the on-screen instructions and the online help topics to define your hosts and associate the HBA host ports. This procedure also allows you to define a host group.

Procedure – Defining the iSCSI Hosts

1. From the **Setup** tab on the Enterprise Management Window, click **Manage a Storage Array**.
The **Select Storage Array** dialog appears.
2. Highlight the storage array on which you want to define a host, and click **OK**.
The associated Array Management Window is launched.
3. From the **Setup** tab on the Array Management Window, click **Configure iSCSI Host Ports**.
4. On the **Configure Ethernet port speed** drop-down list, select either **10 Gbps** or **1 Gbps** to set the port speed to either 10 Gb/s or 1 Gb/s. By default, this value is set to **10 Gbps**.
5. Use the on-screen instructions and the online help topics to further define your hosts and associate the HBA host ports. This procedure also allows you to define a host group.

Step 17 – Configuring the Storage

This topic describes how you can group and manage your storage within the storage array for maximum efficiency.

Key Terms

Default Group

A standard node to which all host groups, hosts, and host ports that do not have any specific mappings are assigned. The standard node shares access to any volumes that were automatically assigned default logical unit numbers (LUNs) by the controller firmware during volume creation.

free capacity

Unassigned space in a volume group that can be used to make a volume.

full disk encryption (FDE)

A type of drive technology that can encrypt all data being written to its disk media.

hot spare drive

A spare drive that contains no data and that acts as a standby in case a drive fails in a RAID Level 1, RAID Level 3, RAID Level 5, or RAID Level 6 volume. The hot spare drive can replace the failed drive in the volume.

Redundant Array of Independent Disks (RAID)

CONTEXT [Storage System] A disk array in which part of the physical storage capacity is used to store redundant information about user data stored on the remainder of the storage capacity. The redundant information enables regeneration of user data in the event that one of the array's member disks or the access path to it fails.

Although it does not conform to this definition, disk striping is often referred to as RAID (RAID Level 0). (The Dictionary of Storage Networking Terminology)

storage partition

A logical entity that is made up of one or more storage array volumes. These storage array volumes can be accessed by a single host or can be shared with hosts that can be part of a host group.

unconfigured capacity

The available space on drives of a storage array that has not been assigned to a volume group.

volume

The logical component created for the host to access storage on the storage array. A volume is created from the capacity available on a volume group. Although a volume might consist of more than one drive, a volume appears as one logical component to the host.

volume group

A set of drives that is logically grouped and assigned a RAID level. Each volume group created provides the overall capacity needed to create one or more volumes.

Things to Know – Data Assurance

The Data Assurance (DA) premium feature checks for and corrects errors that might occur as data is communicated between a host and a storage array. DA is implemented using the SCSI direct-access block-device protection information model. DA creates error-checking information, such as cyclic redundancy checks (CRCs) and appends that information to each block of data. Any errors that might occur when a block of data is either transmitted or stored are then detected and corrected by checking the data with its error-checking information.

Only certain configurations of hardware, including DA-capable drives, controllers, and host interface cards (HICs), support the DA premium feature. When you install the DA premium feature on a storage array, SANtricity ES Storage Manager provides options to use DA with certain operations. For example, you can create a volume group that includes DA-capable drives, and then create a volume within that volume group that is DA-enabled. Other operations that use a DA-enabled volume have options to support the DA premium feature.

If you choose to create a DA-capable volume group, select the **Create a Data Assurance (DA) capable volume group** check box. This check box is enabled only when there is at least one DA-capable drive in the storage array and is, by default, selected if it is enabled.

When the DA premium feature is enabled, the DA Enabled column appears in the **Source volume** list in the **Create Copy Wizard – Introduction** dialog. If you choose to copy a DA-enabled source volume to a target volume that is not DA enabled, you are prompted to confirm your choice. The copy can be completed, but the resulting copy is not DA enabled.



NOTE If a volume group is DA-capable and contains a DA-enabled volume, use only DA-capable drives for hot spare coverage. A volume group that is not DA capable cannot include a DA-enabled volume.

You can verify that a drive contains DA-enabled volumes by checking that the **Data Assurance (DA) capable** property is set to **yes**.

Things to Know – Allocating Capacity

- You can create volumes from either unconfigured capacity or free capacity on an existing volume group.
 - If you create a volume from unconfigured capacity, you must first specify the parameters for a new volume group (RAID level and capacity for a set of drives) before you specify the parameters for the first volume on the new volume group.
 - If you create a volume from free capacity, you have to specify the parameters of only the volume, because the volume group already exists.
- As you configure the capacity on the storage array, make sure that you leave some unassigned drives available. You might need to use these drives for these reasons:
 - To create additional volume groups for new capacity requirements
 - For hot spare drive protection
 - To increase the free capacity on an existing volume group to provide for future capacity needs
 - For additional storage required for certain premium features, such as Snapshot Volume

- If your storage array contains more than one type of drive (such as Fibre Channel or SATA), an Unconfigured Capacity node will be associated with each drive type. You cannot mix drives of different types within the same volume group.
- If you are adding capacity to a Data Assurance (DA) -capable volume group, use only drives that are DA capable. If you add a drive or drives that are not DA-capable, the volume group no longer has DA capabilities, and you no longer have the option to enable DA on newly created volumes within the volume group. The DA Capable column in the **Available drives** list shows the DA capabilities of each listed drive.
- If you are adding capacity to a volume group that is not DA capable, do not use drives that are DA capable because the volume group will not be able to take advantage of the capabilities of DA-capable drives. The DA Capable column in the **Available drives** list shows the DA capabilities of each listed drive.

Things to Know – Volume Groups and Volumes

- You can create a single volume or multiple volumes per volume group. Usually, you will create more than one volume per volume group to address different data needs or because of limits on the maximum capacity of a single volume.

 **NOTE** If you choose to copy a Data Assurance (DA)-enabled source volume to a target volume that is not DA enabled, you are prompted to confirm your choice. The copy can be completed, but the resulting copy is not DA enabled. For more information about how volume copy is affected by DA-enabled volumes, refer to *Volume Copy Premium Feature* electronic document topics or the PDF located on the SANtricity ES Storage Manager Installation DVD.

- While creating volume groups, you must make sure that the drives that comprise the volume group are located in different drive trays. This method of creating volume groups is called tray loss protection. Tray loss protection guarantees accessibility to the data on the volumes in a volume group if a total loss of communication occurs with a single drive tray. Communication loss might occur due to loss of power to the drive tray or failure of the drive tray ESMs.
- The RAID levels supported are RAID Level 0, RAID Level 1, RAID Level 3, RAID Level 5, RAID Level 6, and RAID Level 10 (1 + 0).
 - RAID Level 0 provides no data redundancy.
 - RAID Level 10 is not a separate RAID level choice but is supported when you create a RAID Level 1 volume group that consists of four or more drives.
 - You can assign RAID Level 1 only to volume groups with an even number of drives.
 - You can assign RAID Level 3 or RAID Level 5 only to volume groups with three or more drives.
 - You can assign RAID Level 6 only to volume groups with five or more drives.

 **NOTE** RAID Level 6 is a premium feature. This premium feature was either already enabled on your storage array at the factory, or you must purchase a feature key file from your storage vendor to enable it.

Things to Know – Host-to-Volume Mappings and Storage Partitions

- Each volume that you create must be mapped to a logical address called a logical unit number (LUN). The host uses this address to access data on the volume.
- When you create a volume manually, you have two choices for mapping:
 - **Default mapping** – Choose this option if you do not intend to use storage partitions. The storage management software will automatically assign a LUN to the volume and make the volume available to all of the hosts that are attached to the storage array in the Default Group (partition).

- **Map later (assign specific mapping)** – Choose this option if you intend to use storage partitions. Use the Define Storage Partition Wizard to indicate the host group or host, specify the volumes that you want the host group or host to access, and access the LUNs to assign to each volume.

Things to Know – Hot Spare Drives

- The hot spare drive adds a level of redundancy to your storage array. It is highly recommended that you create hot spare drives for each type of drive in your storage array.
- Hot spare drives do *not* provide protection for RAID Level 0 volume groups because data redundancy does not exist on these volume groups.
- A hot spare drive is *not* dedicated to a specific volume group but instead is global, which means that a hot spare drive will be used for any failed drive in the storage array. The failed drive must be the same drive type and have a capacity that is equal to or smaller than the particular hot spare drive.

Things to Know – Full Disk Encryption

SafeStore Drive Security and SafeStore Enterprise Key Manager (EKM) are premium features that prevent unauthorized access to the data on a drive that is physically removed from the storage array. Controllers in the storage array have a *security key*. Secure drives provide access to data only through a controller that has the correct security key. The security key can be managed locally by the controllers or externally by an external key management server, which is the EKM premium feature. Both SafeStore Drive Security and EKM must be enabled either by you or your storage vendor.

The SafeStore Drive Security premium feature requires security-capable full disk encryption (FDE) drives. A security-capable FDE drive encrypts data during writes and decrypts data during reads. Each security-capable drive has a unique drive encryption key.

When you create a secure volume group from security-capable FDE drives, the drives in that volume group become security enabled. When a security-capable FDE drive has been security enabled, the drive requires the correct security key from a controller to read or write the data. All of the drives and controllers in a storage array share the same security key. The shared security key provides read and write access to the drives, while the drive encryption key on each drive is used to encrypt the data. A FDE drive works like any other drive until it is security enabled.

Whenever the power is turned off and turned on again or is removed from the controller-drive tray, all of the FDE drives change to a *security locked* state. In this state, the data is inaccessible until the correct security key is provided by a controller.

You can view the SafeStore Drive Security status of any drive in the storage array from the **Drive Properties** dialog. The status information reports whether the drive is:

- Security-capable
- Secure – Security enabled or disabled
- Read/Write Accessible – Security locked or unlocked

You can view the security status of any volume group in the storage array from the **Volume Group Properties** dialog. The status information reports whether the storage array is one of the following:

- Security-capable
- Secure

The following table shows how to interpret the security properties status of a volume group.

Volume Group Security Properties

| | Security-Capable – Yes | Security-Capable – No |
|---------------------|--|---|
| Secure – Yes | The volume group is composed of all FDE drives and is in a Secure state. | Not applicable. Only FDE drives can be in a Secure state. |
| Secure – No | The volume group is composed of all FDE drives and is in a Non-Secure state. | The volume group is not entirely composed of FDE drives. |

When the SafeStore Drive Security premium feature has been enabled, the **Drive Security** menu appears in the **Storage Array** menu. The **Drive Security** menu has these options:

- **Create Security Key**
- **Change Security Key**
- **Save Security Key**
- **Unlock Drives**



NOTE If you have not created a security key for the storage array, only the **Create Security Key** option is active.

If you have created a security key for the storage array, the **Create Security Key** option is inactive with a check mark to the left. The **Change Security Key** option and the **Save Security Key** options are now active.

The **Unlock Drives** option is active if any security-locked drives exist in the storage array.

When the SafeStore Drive Security premium feature has been enabled, the **Secure Drives** option appears in the **Volume Group** menu. The **Secure Drives** option is active if these conditions are true:

- The selected storage array is not security enabled but is composed entirely of security-capable drives.
- The storage array contains no snapshot base volumes or snapshot repository volumes.
- The volume group is in Optimal status.
- A security key is set up for the storage array.

The **Secure Drives** option is inactive if the previous conditions are not true.

The **Secure Drives** option is inactive with a check mark to the left if the volume group is already security enabled.

You can erase security-enabled drives instantly and permanently so that you can reuse the drives in another volume group or in another storage array. You can also erase them if the drives are being decommissioned. When you erase security-enabled drives, the data on that drive becomes permanently inaccessible and cannot be read. When all of the drives that you have selected in the Physical pane are security enabled, and none of the selected drives is part of a volume group, the **Secure Erase** option appears in the **Drive** menu.

The storage array password protects a storage array from potentially destructive operations by unauthorized users. The storage array password is independent from the SafeStore Drive Security premium feature and should not be confused with the pass phrase that is used to protect copies of a SafeStore Drive Security security key. However, it is good practice to set a storage array password before you create, change, or save a SafeStore Drive Security security key or unlock secure drives.

Procedure – Configuring the Storage

1. From the **Setup** tab on the Enterprise Management Window, click **Manage a Storage Array**.
The **Select Storage Array** dialog appears.
 2. Highlight the storage array on which you want to configure storage, and click **OK**.
The associated Array Management Window is launched.
 3. From the **Setup** tab on the Array Management Window, click **Configure Storage Array**.
 4. Choose the applicable configuration task:
 - **Automatic configuration** – This method creates volume groups with equal-sized capacity volumes and also automatically assigns appropriate hot spare drive protection. Use this method if you do not have unique capacity requirements for each volume or you want a quick method to configure volume groups, volumes, and hot spare drives. You can choose from a list of suggested configurations, or you can create your own custom configuration.
 - **Create volume groups and volumes** – This method creates one volume at a time but gives you more control over the volume group and volume parameters (such as RAID level, volume group, volume capacity, and so on). Use this method if you have unique capacity requirements for most of the volumes that you will create and you want more control in specifying various parameters.
 - **Configure hot spare drives** – This method lets you either have the software automatically assign applicable hot spare protection (which is identical to the automatic configuration method described previously) or manually create a hot spare drive from an unassigned drive that you select.
 5. To create the volume groups, volumes, and hot spare drives, perform one of these actions depending on your storage partition requirements. Refer to the on-screen instructions and the online help topics for more information.
 - **No storage partition is required, and you selected the automatic configuration method** – Go to step 6.
 - **No storage partition is required, and you selected the manual configuration method** – Verify whether all volumes are mapped to the Default Group, and go to step 8.
 - **A storage partition is required** – Go to step 7.
 6. Perform these actions:
 - a. From the **Setup** tab on the Array Management Window, click **Map Volumes**.
 - b. Select the Default Group, and assign each volume a logical unit number (LUN).
 - c. Go to step 8.
-
- 
- NOTE** To map all volumes into the Default Group, you must select the **Default Mapping** option while creating the volumes.
-
7. Perform these actions:
 - a. Click the **Mappings** tab.
 - b. Specify the applicable host or host group, volumes, and LUNs.
 - c. Select **Mappings >> Define**, and click **SANshare Storage Partitioning**.
 - d. Refer to the on-screen instructions.

- e. Repeat step a through step d for each storage partition.
 - f. Go to step 8.
8. After you have created all of the volumes and mappings, use the applicable procedures on your hosts to register the volumes and to make them available to your operating system.
- Depending on your operating system, two utilities are included with the storage management software (`hot_add` and `SMdevices`). These utilities help register the volumes with the hosts and also show the applicable device names for the volumes.
 - You also will need to use specific tools and options that are provided with your operating system to make the volumes available (that is, assign drive letters, create mount points, and so on). Refer to your host operating system documentation for details.
 - If you are using the HP-UX OS, you must run this command on each host to change the I/O timeout value to 120 seconds on each block device (volume) that you created on the storage array, where `cxtxdx` is the device name of each volume.

```
pvchange -t 120 /dev/dsk/cxtxdx
```



NOTE If you reboot your host, you must run the `pvchange` command again.



NOTE After you configure the volume, you can change the cache memory settings of the volume. See [“Procedure – Changing the Volume Cache Memory Settings.”](#)

Step 18 – Downloading the Drive and ATA Translator Firmware for SATA Drives and the DE6900 Drive Tray

Each SATA drive in a DE6900 drive tray is connected to a corresponding ATA translator (12 to a drawer). The ATA translator provides Fibre Channel (FC) protocol to Serial Advanced Technology Attachment (SATA) protocol translation for the SATA drives in the storage array.

Use the **Drive/ATA Translator Firmware** option to transfer a downloadable firmware file to the drives and the Advanced Technology Attachment (ATA) translators in the storage array only if the drives and the ATA translators in the storage array are experiencing firmware-related limitations or performance issues. Obtain drive and ATA translator firmware only from your storage supplier.

You can download firmware files to multiple drives and ATA translators at a time to keep downtime to a minimum.

 **ATTENTION Risk of application errors** – Stop all I/O activity to the storage array before downloading the firmware to prevent application errors. Before starting any firmware download, make sure that all data on the affected drives is backed up.

Keep these important guidelines in mind when you download firmware to avoid the risk of application errors:

- Downloading firmware incorrectly could result in damage to the drives or loss of data. Perform downloads only under the guidance of your Customer and Technical Support representative.
 - Stop all I/O to the storage array before the download.
 - Make sure that the firmware that you download to the drives and the ATA translators is compatible with the drives and the ATA translators that you select.
 - Do not make any configuration changes to the storage array while downloading the firmware.
-

 **ATTENTION Possible loss of data** – Perform downloads only under the guidance of your Customer and Technical Support representative. Downloading firmware files incorrectly could result in performance problems or loss of data.

 **ATTENTION Possible damage to drives and loss of data** – Do not make any configuration changes to the storage array while downloading firmware files.

 **NOTE** Before you download firmware to all of the drives, and the ATA translators in the storage array, consider downloading to just a few drives and ATA translators to make sure that the downloads are successful and to test the performance of the new firmware. When you are satisfied that the new firmware works correctly, download the firmware to the remaining drives and ATA translators.

 **NOTE** Downloads can take several minutes to complete. During a download, the **Download Drive and ATA Translator - Progress** dialog appears. Do not attempt another operation when the **Download Drive and ATA Translator – Progress** dialog is shown.

1. From the Array Management Window, select **Advanced > Maintenance > Download > Drive/ATA Translator Firmware**.

The **Download Drive and ATA Translator Firmware - Introduction** dialog appears.

2. Follow the directions on each dialog, and click **Next** to move to the next dialog.

Each dialog has context-sensitive help. Click **Help** to view the information applicable for that particular dialog.

Things to Know – A Preview of the Download Drive and ATA Translator Firmware Dialog

| Dialog | Description |
|--|---|
| Download Drive and ATA Translator Firmware Wizard – Introduction | Provides information about downloading the firmware to the drives and the ATA translators. |
| Download Drive and ATA Translator Firmware Wizard – Select Packages | Lets you select the firmware for the drives and the ATA translators. |
| Download Drive and ATA Translator Firmware Wizard – Select Services | Lets you select the drives and the ATA translators that you want to update with the previously selected firmware. |
| Download Drive and ATA Translator Firmware Wizard – Download Progress | Lets you monitor the progress of the firmware download. |

Procedure – Starting the Download Process

The **Download Drive and ATA Translator Firmware - Introduction** dialog is the first dialog of the Download Drive and ATA Translator Firmware Wizard that downloads drive and Advanced Technology Attachment (ATA) translator firmware to one or more drives and ATA translators in the storage array.

1. Review the information in the dialog to determine whether you are ready to download the firmware.
2. To continue with the firmware download process, click **Next**.

Procedure – Selecting the Drive and the ATA Translator Firmware

Use the **Download Drive and ATA Translator Firmware - Select Packages** dialog to select the drive and Advanced Technology Attachment (ATA) translator firmware that you want to download.

1. To open the dialog to select the firmware, click **Add**, and navigate to the directory that contains the files that you want to download.
2. Select up to four firmware files.



NOTE Selecting more than one firmware file to update the firmware of the same drive or ATA translator might result in a file-conflict error. If a file-conflict error occurs, an error dialog appears. To resolve this error, click **OK**, and remove all other firmware files except the one that you want to use for updating the firmware of the drive or the ATA translator. To remove a firmware file, select the firmware file in the Selected packages area, and click **Remove**.

3. To move to the next dialog, click **Next**.

Procedure – Updating the Firmware

Use the **Download Drive and ATA Translator Firmware - Select Devices** dialog to select the drives and the Advanced Technology Attachment (ATA) translators that you want to update with the previously selected firmware. The selected firmware for the drive appears in the Drive firmware information area. The selected firmware for the ATA translator appears in the ATA translator firmware information area. If you must change the firmware, click **Back** to return to the previous dialog.

1. Select the drives and ATA translators for which you want to download the firmware.
 - **For one or more drives and ATA translators** – In the Select devices area, select the drive and ATA translator names.
 - **For all compatible drives and ATA translators listed in the dialog** – Click **Select All**.
2. Click **Finish**.
The **Confirm Download** dialog appears.
3. To start the firmware download, type `yes` in the text box.
4. Click **OK**.

Procedure – Monitoring the Progress of the Download

Use the **Download Drive and ATA Translator Firmware - Progress** dialog to monitor the progress of the drive and the Advanced Technology Attachment (ATA) translator firmware download.



ATTENTION Possible loss of access to data or data loss – Stopping a firmware download might result in drive unavailability or data loss.

1. Monitor the progress of the drive and the ATA translator firmware download. The progress and status of each drive and each ATA translator that are participating in the download appears in the Progress column of the Devices updated area and in the Progress summary area.



NOTE Each firmware download can take several minutes to complete.

| Status Shown | Definition |
|------------------------|--|
| Scheduled | The firmware download has not yet started. |
| In progress | The firmware is being transferred to the drive or the ATA translator. |
| Failed - partial | The firmware was only partially transferred to the drive before a problem prevented the rest of the file from being transferred. |
| Failed - invalid state | The firmware is not valid. |
| Failed - other | The firmware could not be downloaded, possibly because of a physical problem with the drive or the ATA translator. |
| Not attempted | The firmware was not downloaded. The download was stopped before it could occur. |

| Status Shown | Definition |
|--------------|---|
| Successful | The firmware was downloaded successfully. |



NOTE A drive or an ATA translator does not show in the Devices updated area until a firmware download is attempted or the firmware download process is stopped.

2. To stop the firmware download in progress, click **Stop**.
Any firmware downloads currently in progress are completed. Any drives or ATA translators that have attempted firmware downloads show their individual status. Any remaining drives or ATA translators are listed with a status of Not attempted.
3. If you want to save a text report of the progress summary, click **Save As**.
The report saves with a default `.txt` file extension. If you want to change the file extension or directory, change the parameters in the **Save As** dialog.
4. Perform one of these actions:
 - **To close the Drive Firmware Download Wizard** – Click **Close**.
 - **To start the wizard again** – Click **Transfer More**.

Remote Volume Mirroring Premium Feature

This topic describes how to obtain, enable, activate, and use the Remote Volume Mirroring premium feature for SANtricity ES Storage Manager Version 10.75.

About the Remote Volume Mirroring Premium Feature

The Remote Volume Mirroring premium feature is for online, real-time replication of data between two storage arrays in separate locations. When you create a remote volume mirror, a mirrored volume pair is created.

The mirrored volume pair is created from two standard volumes, which are logical structures that are created on a storage array for data storage. A standard volume can be a member of only one mirrored pair. The pair consists of a primary volume at a local storage array and a secondary volume at a remote storage array.

If a disaster occurs, or if there is a catastrophic failure in the local storage array, you can promote the secondary volume in the remote storage array to the role of primary volume to take over responsibility for maintaining computer operations.

Primary Volumes and Secondary Volumes

Before you can create a remote volume mirror, you must enable and activate the Remote Volume Mirroring premium feature on both the local storage array and the remote storage array. If a volume does not exist on either the local storage array or the remote storage array, you must create the volumes. Both the local storage array and the remote storage array show the primary volume and the secondary volume.

When both the primary volume and the secondary volume are available, you can create a mirrored pair. When the remote volume mirror is first created, a full synchronization automatically occurs. The data from the primary volume is copied completely to the secondary volume.

Mirror Repository Volumes

When you activate the Remote Volume Mirroring premium feature on the storage array, two mirror repository volumes are created in one of the volume groups on the storage array. The controller stores mirroring information on this volume, which includes information about remote writes that are not yet complete. You can use this information to recover from controller resets and the accidental shutting down of storage arrays.

- **Capacity of the mirror repository volumes –**
 - You can create the mirror repository volumes from the unconfigured free capacity of the volume group.
 - You can create a new volume group and its member mirror repository volumes from the unconfigured free capacity of the storage array.
 - The default names of the mirror repository volumes are Mirror Repository 1 and Mirror Repository 2. You cannot change these names.
 - The activation process creates the mirror repository volumes with equal capacity. In a dual controller storage array, the default capacity for both mirror repository volumes is either 128 MB or 256 MB. You can neither increase the capacity nor decrease the capacity.
- **Mirror RAID levels of the mirror repository volumes –** When you activate the Remote Volume Mirroring premium feature and create the volume group and mirror repository volumes from the unconfigured free capacity of the storage array, you select the RAID level for the volume group. However, when you create the mirror repository volumes from an existing storage array, you do not select the RAID level.



ATTENTION Potential loss of data – Because the data stored on the mirror repository volumes is critical, do not create mirror repository volumes in an existing volume group that has RAID level 0. If you create a new volume group for the mirror repository volumes, do not select RAID level 0.

Using Other Premium Features with Remote Volume Mirroring

You can use the Remote Volume Mirroring premium feature with the following premium features that are enabled and active on the primary storage array.

- **SANshare® Storage Partitioning** – Go to [Using the SANshare Storage Partitioning Premium Feature with Remote Volume Mirroring](#).
- **Snapshot Volume** – Go to [Using the Snapshot Volume Premium Feature with Remote Volume Mirroring](#).
- **Volume Copy** – Go to [Using the Volume Copy Premium Feature with Remote Volume Mirroring](#).
- **Dynamic Volume Expansion (DVE)** – Go to [Using the Dynamic Volume Expansion Premium Feature with Remote Volume Mirroring](#).

Using the SANshare Storage Partitioning Premium Feature with Remote Volume Mirroring

The SANshare Storage Partitioning premium feature lets hosts share access to volumes in a storage array. A storage partition is created when you define a collection of hosts (a host group) or a single host and then define a volume-to-logical unit number (LUN) mapping. This mapping lets you define which host group or host will have access to a particular volume in the storage array.

The storage partition definitions for the local storage array and the remote storage array are independent of each other. If these definitions are put in place while the secondary volume is in a secondary role, it reduces the administrative effort that is associated with site recovery if it becomes necessary to promote the volume to a primary role.

Using the Snapshot Volume Premium Feature with Remote Volume Mirroring

A snapshot volume is a point-in-time image of a volume. Do not mount a snapshot volume on the same server on which the primary volume is mounted in a remote volume mirror.

Using the Volume Copy Premium Feature with Remote Volume Mirroring

The Volume Copy premium feature copies data from a source volume to a target volume within the same storage array.

- A primary volume in a remote volume mirror can be either a source volume or a target volume in a volume copy.
- You can create a volume copy on the primary volume in a mirrored pair, but you cannot create a volume copy on a secondary volume in a mirrored pair. You can make a copy of a secondary volume in two ways:
 - Promote the secondary volume to the role of primary volume.



ATTENTION Potential loss of data access – If a role reversal is started while a volume copy is in progress, the volume copy fails and cannot be restarted.

- Create a snapshot volume of the secondary volume, and then perform a volume copy on the snapshot volume.

Using the Dynamic Volume Expansion Premium Feature with Remote Volume Mirroring

Dynamic Volume Expansion (DVE) increases the capacity of a volume. The increased capacity is achieved by using the free capacity that is available on the volume group of the standard volume or the snapshot repository volume.

Performing a DVE operation does not interrupt access to data on volume groups, volumes, or drives.

You can perform a DVE operation on a primary volume or a secondary volume of a mirrored pair. However, you cannot perform a DVE operation on a mirror repository volume.



NOTE To perform a DVE operation, the remote volume mirror must be in an Optimal status. The Properties pane in Logical view shows the status of a volume.

Switching Zoning Configurations for Remote Volume Mirroring

Because of possible restrictions at the host level, the Remote Volume Mirroring configurations contain Fibre Channel switches. These Fibre Channel switches are zoned so that a single host adapter can access only one controller in a storage array. Additionally, all configurations use a separate zone for the ports that are reserved for the Remote Volume Mirroring premium feature.



IMPORTANT Do not zone the uplink port (E_port) that connects (cascades) switches within a fabric.

Switch zoning configurations are typically set up by using the switch management software that is provided by the manufacturer of the Fibre Channel switch. This software should have been included with the materials that were provided when the switch was purchased.

When two or more Fibre Channel switches are cascaded together, the switch management software combines the ports for all of the switches that are linked. For example, if two 16-port Fibre Channel switches are cascaded with a physical connection using a Fibre Channel cable, the switch management software shows ports 0 through 31 participating in the fabric rather than two switches each with ports 0 through 15. Therefore, a zone that is created containing any of these ports can exist on multiple cascaded switches.

Journaling File Systems and Remote Volume Mirroring

When you are using a journaling file system, you cannot gain read-only access to a remote volume. A journaling file system does not let you mount the remote volume in Windows (NTFS); however, you can mount the snapshot of the remote volume.

Prerequisites for Creating a Remote Volume Mirror

Make sure the following prerequisites have been met before you create a remote volume mirror between two storage arrays:

- The Remote Volume Mirroring premium feature has been activated. For more information about enabling and activating the premium feature, go to [Activating the Remote Volume Mirroring Premium Feature](#).
- The local storage array contains two mirror repository volumes.
- The local storage array contains the primary volume, and the remote storage array contains the secondary volume. If either volume does not exist, you must create it before you can create the remote volume mirror.
- The secondary volume meets these requirements:
 - The RAID level of the secondary volume can be different from the RAID level of the primary volume.
 - The capacity of the secondary volume must be equal to or greater than the capacity of the primary volume.

Obtaining the Remote Volume Mirroring Premium Feature Key

Before you can create a remote volume mirror, you must obtain the Remote Volume Mirroring premium feature key, enable the premium feature, and activate it. If you have purchased the Remote Volume Mirroring premium feature, contact your Customer and Technical Support representative to obtain the premium feature key. The Customer and Technical Support representative will need the 30-character string in the **Feature Enable Identifier** field in the **Premium Features and Feature Pack Information** window.

1. In the Array Management Window, select **Storage Array >> Premium Features**.

The **Premium Features and Feature Pack Information** window opens. The **Premium Features** list shows the premium features that are installed on the storage array.

2. Find and record the 30-character string in the **Feature Enable Identifier** field.

The Customer and Technical Support representative uses the Feature Enable Identifier to generate the premium feature key.

3. Contact the Customer and Technical Support representative to obtain the premium feature key.
4. Copy the Remote Volume Mirroring premium feature key to a directory from which you can retrieve it.

The default directory is `C:\Documents and Settings\My Documents`.



NOTE You can enable and activate the Remote Volume Mirroring premium feature now, or you can wait until you are ready to create a remote volume mirror.

Enabling the Remote Volume Mirroring Premium Feature

Before you can create a remote volume mirror, you must obtain the premium feature key, enable the premium feature, and activate it. You do not have to activate the Remote Volume Mirroring premium feature until you are ready to use it.

1. On the menu bar in the Array Management Window, select **Storage Array >> Premium Features**.

The **Premium Features and Features Pack** window opens and shows a list of premium features installed on the storage array.

2. Select **Remote Volume Mirroring**, and click **Enable**.

The `My Documents` directory appears.

3. Is the Remote Volume Mirroring premium feature key file in the `My Documents` directory?

- **Yes** – Go to step 4.
- **No** – Navigate to the appropriate directory, and go to step 4.

4. Select the Remote Volume Mirroring premium feature key file, and click **OK**.

The Enable Premium Feature confirmation message appears.

5. Click **Yes**.

The Premium Features installed on storage array list shows the Remote Volume Mirroring premium features as enabled but deactivated.

Activating the Remote Volume Mirroring Premium Feature

Before you can create a remote volume mirror, you must obtain the Remote Volume Mirroring premium feature key, enable the premium feature, and activate it. You do not have to activate the Remote Volume Mirroring premium feature until you are ready to use it.

When you activate the Remote Volume Mirroring premium feature, two default mirror repository volumes are created.

- The default names of the mirror repositories are Mirror repository 1, which is owned by controller A, and Mirror repository 2, which is owned by controller B. You cannot change the default names of the mirror repository volumes.
- The mirror repository volumes have either 128-MB or 256-MB volume capacity. You cannot change the default capacities of the mirror repository volumes.

To activate the Remote Volume Mirroring premium feature, perform these steps:

1. On the menu bar in the Array Management Window, select **Storage Array >> Remote Volume Mirroring >> Activate**.

The Introduction (Activate Remote Volume Mirroring) wizard appears.

2. Select how to assign volume capacity and where to place the mirror repository volumes.

You can select how to assign volume capacity and where to place the mirror repository volumes in two ways:

- **From the free capacity of existing volume groups** – Go to [Creating Mirror Repository Volumes in an Existing Volume Group](#).
- **From the unconfigured free capacity of the storage array** – Go to [Creating a Volume Group and Mirror Repository Volumes from the Unconfigured Capacity of the Storage Array](#).

Creating a Volume Group and Mirror Repository Volumes from the Unconfigured Capacity of the Storage Array

You can use the total unconfigured capacity of the storage array, or you can use the unconfigured capacity of the unassigned drives in the storage array.

1. In the Introduction (Activate Remote Volume Mirroring) wizard, select **Unconfigured capacity (create a new volume group)**, and click **Next**.

The Activate Remote Volume Mirroring - Create Volume Group wizard appears.

2. In the **Volume Group Name** text box, type a unique name for the volume group.
3. Select one of the drive selection methods.
 - **Automatic** – The storage management software generates a list of available capacity and drive options for each available RAID level.
 - **Manual** – The storage management software generates a list of unselected drives.
4. Click **Next**.
 - If you selected **Automatic**, an empty Select Capacity table and a drop-down list of available RAID levels appear. Go to step 5.
 - If you selected **Manual**, a populated Unselected Drives table, an empty Selected Drives table, and a drop-down list of available RAID levels appears.
5. On the **Select RAID level** drop-down list, select the RAID level for the volume group.

The Select capacity table shows the available volumes for the RAID level.

6. In the Select capacity table, select the drives and capacities for the new volume group, and click **Next**.
The Preview (Activate Remote Volume Mirroring) wizard appears.
7. Click **Finish**.
The Completed (Activate Remote Volume Mirroring) message appears.
8. Click **OK**.
The Remote Volume Mirroring premium feature is active, and the Logical pane shows the new volume group and the two member mirror repository volumes.

Creating Mirror Repository Volumes in an Existing Volume Group

The capacity of the mirror repository volumes comes from the free capacity in the existing volume group. By default, the mirror repository volumes each have either 128-MB or 256-MB capacity. You cannot create the mirror repository volumes on a volume group with insufficient capacity. You cannot change the default capacities of the mirror repository volumes.

1. In the Introduction (Activate Remote Volume Mirroring) wizard, select **Free capacity on existing volume groups**.
2. From the list of available volume groups, select a volume group in which to place the mirror repository volumes, and click **Next**.
The Preview (Activate Remote Volume Mirroring) wizard appears.
3. Click **Finish**.
The Completed (Activate Remote Volume Mirroring) message appears.
4. Click **OK**.
The Remote Volume Mirroring premium feature is active, and the Logical pane shows the two mirror repository volumes in the volume group.

Creating a Remote Volume Mirror

Before you create a remote volume mirror, verify that all of the prerequisites have been met. For more information, go to [Prerequisites for Creating a Remote Volume Mirror](#).

1. Open the Array Management Windows of both the local storage array and the remote storage array.
2. Verify that the Remote Volume Mirroring premium feature has been activated on both the local storage array and the remote storage array
3. In the Array Management Window of the local storage array, select the **Logical** tab.
4. In the Logical pane of the local storage array, select the primary volume for the remote volume mirror.
5. On the menu bar in the Array Management Window, select **Volume >> Remote Volume Mirroring >> Create**.

The Introduction (Activate Remote Volume Mirroring) wizard appears.

6. Click **Next**.

The **Select Storage Array (Create Remote Volume Mirror)** dialog appears. The **Storage Arrays** list shows the remote storage arrays.

7. Select a storage array, and click **Next**.

The Select Secondary Volume (Create Remote Volume Mirror) wizard appears.

8. Go to [Selecting the Secondary Volume](#).

Selecting the Secondary Volume

Prerequisite: Before you select the secondary volume, perform these tasks on the secondary volume candidate:

1. Back up all data to the volume.
2. Stop all I/O activity to the volume.
3. Unmount the file system of the volume.

After you have selected the remote storage array and the primary volume, perform these steps:

1. In the Select Secondary Volume (Create Remote Volume Mirror) wizard, select the secondary volume.



IMPORTANT The secondary volume must have a capacity equal to or greater than the capacity of the primary volume.

2. Click **Next**.

The Set Write Mode (Create Remote Volume Mirror) wizard appears.

3. Go to [Setting the Write Mode](#).

Setting the Write Mode

The secondary host ports on the storage arrays are reserved for data synchronization between the primary volume and the secondary volume in a mirrored volume pair. You can set the remote volume mirror to write either synchronously or asynchronously.

- **Synchronous mode** – In the synchronous mode, the controller on the primary volume on the storage array sends an I/O completion message back to the host storage array after the data has been successfully copied to the secondary storage array. The synchronous mode is the preferred mode of operation because it offers the best chance of full data recovery from the secondary storage array in the event of a disaster; however, the data recovery can degrade the I/O performance of the host.
- **Asynchronous mode** – In the asynchronous mode, the controller on the primary storage array sends an I/O completion message to the host storage array before the data has been successfully copied to the secondary storage array. The asynchronous mode offers faster host I/O performance; however, it does not guarantee that data was successfully written to the secondary volume or that the write requests were completed on the secondary volume in the same order they were initiated.



NOTE If you select the asynchronous mode, select whether to add the secondary volume to a write consistency group.

- **Add to write consistency group option** – A write consistency group makes sure that the secondary volume receives write requests in the sequence initiated by the controller of the primary volume. You have the option of adding the secondary volume to a write consistency group.

To set the write mode for the remote volume mirror, perform these steps:

1. In the Set Write Mode (Create Remote Volume Mirror) wizard, select either the **Synchronous mode** or the **Asynchronous mode**.
2. Click **Next**.
The Select Synchronization Settings (Create Remote Volume Mirror) wizard appears.
3. Go to [Setting the Synchronization Priority and the Synchronization Method](#).

Setting the Synchronization Priority and the Synchronization Method

You can set the priority for allocating system resources to synchronizing the remote volume mirror. When a remote volume mirror synchronizes, system resources are allocated to the process.

- Higher synchronization priorities allocate more resources to the process and might degrade I/O performance.
- Lower synchronization priorities allocate fewer resources to the process and have less impact on normal I/O performance.

After you set the initial synchronization priority and synchronization method, you can change it. For more information about resynchronizing volumes in a remote volume mirror, go to [Resynchronizing Volumes in a Remote Volume Mirror](#).

1. In the Select Synchronization Settings (Create Remote Volume Mirror) wizard, select the synchronization priority on the **Priority** slide bar.
2. Select either **Manual resynchronization** or **Automatic resynchronization**.
 - **Automatic resynchronization** – Resynchronization starts immediately after communication is restored between unsynchronized mirrored volumes.
 - **Manual resynchronization**– The mirrored pair must be manually resynchronized each time communication is restored between unsynchronized mirrored volumes.
3. Click **Next**.
The Preview (Create Remote Volume Mirror) wizard appears.
4. Go to [Completing the Remote Volume Mirror](#).

Completing the Remote Volume Mirror

After you have selected the synchronization settings, perform these steps to complete the remote volume mirror.

1. In the text box in the Preview (Create Remote Volume Mirror) wizard, type `Yes`, and click **Finish**.
 - If other volumes on the remote storage array meet the criteria to be a secondary volume, the Creation Successful (Create Remote Volume Mirror) confirmation message appears. Go to step 2.
 - If no other volumes on the remote storage array meet the criteria to be a secondary volume, the Completed (Create Remote Volume Mirror) message appears. Go to step 3.
2. Are you creating another remote volume mirror?
 - **Yes** – Click **Yes**. The **Select Primary Volume (Create Remote Volume Mirror)** dialog appears. To continue creating another remote volume mirror, go to [Creating a Remote Volume Mirror](#).
 - **No** – Click **No**. The Completed (Create Remote Volume Mirror) message appears. Go to step 3.
3. On the **Completed (Create Remote Volume Mirror)** message, click **OK**.
 - In the Array Management Windows of both the local storage array and the remote storage array, the Logical panes show the mirrored volume pairs as members of their volume groups. In the Array Management Window of the local storage array, the Properties pane shows the Mirror status as Synchronizing, and the Synchronization - Progress bar shows the estimated time to completion.
 - To view detailed information about the volumes in a remote volume mirror, go to either [Viewing Information about a Remote Volume Mirror or a Mirror Repository Volume in the Properties Pane](#) or [Viewing Information about a Remote Volume Mirror or a Mirror Repository Volume in the Storage Array Profile](#).

Controller Ownership/Preferred Path in a Remote Volume Mirror

During a remote volume mirroring operation, the same controller must own both the primary volume and the secondary volume. If both volumes do not have the same preferred controller when a remote volume mirror starts, the ownership of the secondary volume is automatically transferred to the preferred controller of the primary volume.

- When the remote volume mirror is completed or is stopped, ownership of the secondary volume is restored to its preferred controller.
- If ownership of the primary volume is changed during the remote volume mirror, ownership of the secondary volume is also changed.

If a controller fails under any of the following conditions, you must manually change controller ownership to the alternate controller to allow the remote volume mirror to finish.

- A remote volume mirror has a status of In Progress.
- The preferred controller of the primary volume fails.
- The ownership transfer does not occur automatically during a failover.



ATTENTION Possible loss of data – Verify that either the volumes are not in use or a multi-path driver is installed on the host. If you change the controller ownership/preferred path while an application is using one of the volumes, I/O activity is disrupted, and I/O errors occur unless a multi-path host is installed on the host. If a multi-path driver is not installed on the host, or if the multi-path driver is not the RDAC multi-path driver, you must make operating system-specific modifications to make sure that the moved volume groups can be accessed on the new path.

To change the controller ownership/preferred path setting, go to [Changing the Controller Ownership/Preferred Path for a Remote Volume Mirror](#).

Changing the Controller Ownership/Preferred Path for a Remote Volume Mirror

1. In the Array Management Window, select the **Logical** tab.
2. In the Logical pane, right-click the the volume for which to change the controller ownership and preferred path.
3. Select **Change >> Ownership/Preferred Path**.
4. Select the new controller.



NOTE A dot identifies the current path and current controller. When the current path and current controller are not the preferred path and preferred controller, you can select them.

The Confirm Change Ownership/Preferred Path message appears.

5. Click **Yes**.

Viewing Information about a Remote Volume Mirror or a Mirror Repository Volume in the Storage Array Profile

The storage array profile shows the most detailed information about the components of a remote volume mirror and the mirror repository volumes. You can view detailed information about individual volumes in a remote volume mirror and paired volumes in a remote volume mirror. You can view detailed information about the mirror repository volumes in a storage array. You can also save the storage array profile information as a text file.

You can also view information about a remote volume mirror in the Properties pane under the **Logical** tab. For more information, go to [Viewing Information about a Remote Volume Mirror or a Mirror Repository Volume in the Properties Pane](#).

You can save all of the information or specific information under the **Repositories** tab or the **Mirrors** tab.

1. In the Array Management Window of either the local storage array or the remote storage array, select the **Summary** tab.
2. In the Status area, click **Storage Array Profile**.
The storage array profile opens.
3. Select the **Volumes** tab.
4. Select either the **Mirrors** tab or the **Repositories** tab.
The Profile for Storage array page appears.
5. Perform either of these actions:
 - **To return to the Array Management Window without saving the information** – Click **Close**.
 - **To save the information** – Click **Save As**, and go to step 6.
6. In the Section Selection area in the **Save Profile** window, perform either of these actions:
 - Select **All Sections**, and go to step 7.
 - Select **Select Sections**, select each section for which to save the information, and go to step 7.
7. To save the file, perform either of these actions.
 - **Save the file in the default My Documents directory** – Go to step 8.
 - **Save the file in another directory** – On the **Look in** drop-down list, select a directory in which to save the file, and go to step 8.
8. In the **File name** text box, type a name for the file, and click **Save**.

The file is saved as a *<Profile date> *.txt* file.

Viewing Information about a Remote Volume Mirror or a Mirror Repository Volume in the Properties Pane

The Properties pane shows of the physical and logical characteristics of a single volume in a mirrored pair or a single mirror repository volume. The Properties pane is view-only. You can view more detailed information or save the information in **Storage Array Profile** under the **Summary** tab. For more information, go to [Viewing Information about a Remote Volume Mirror or a Mirror Repository Volume in the Storage Array Profile](#).

1. In the Array Management Window, select the **Logical** tab.
2. In the Logical pane, select either the primary volume or the secondary volume in the mirrored pair.

The Properties pane shows the properties for the selected volume. The Mirror status under Mirroring properties shows the synchronization status of the mirrored pair. When the primary and secondary volumes are synchronizing, the Mirror status shows a synchronizing icon.

Viewing the Logical Elements of the Secondary Volume in a Remote Volume Mirror

1. In the Array Management Window of local storage array, select the **Logical** tab.
2. In the Logical pane, right-click the secondary volume of the remote volume mirror.
3. Select **View Associated Logical Elements**.

The **View Associated Logical Elements** pop-up appears and shows these logical elements:

- The primary volume and secondary volume and their locations.
- The mirror repository volumes and their locations.

Viewing the Physical Components or the Logical Elements of the Primary Volume in a Remote Volume Mirror

1. In the Array Management Window of the storage array that contains the primary volume, select the **Logical** tab.
2. In the Logical pane, right-click the primary volume, and perform either of these actions:
 - **View the logical elements of the primary volume** – Select **View >> Associated Logical Elements**. The **View Associated Logical Elements** pop-up appears and shows visual representations of these elements: the primary volume and the secondary volume in the remote volume mirror and their locations and the mirror repository volumes in the storage array and their locations.
 - **View the physical components of the primary volume** – In the Properties pane, click **View Associated Physical Components**. The **View Associated Physical Components** pop-up appears and shows a visual representation of the primary volume in the remote volume mirror.

Changing the Write Mode and the Consistency Group Membership in a Remote Volume Mirror

The write mode of a remote volume mirror is selected when it is created. When you change the write mode in an remote volume mirror, you can also change the secondary volume's membership in a write consistency group. For more information about write modes and write consistency groups, go to [Setting the Write Mode](#).



IMPORTANT Before you change the write mode, verify the current write mode to make sure that the change you are making is to the other write mode.

1. In the Array Management Window of the storage array that contains the primary volume, select the **Logical** tab.
2. In the Logical pane, right-click the primary volume of the mirrored pair.
3. Select **Change >> Write Mode**.

The **Change Write Mode** dialog appears. The Mirrored pairs table shows all mirrored pairs in both the local storage array and the remote storage array.

4. Select one or more mirrored pairs. To select all mirrored pairs, click **Select All**.
5. Select either the synchronous write mode or the asynchronous write mode.
6. Are you adding the secondary volume of the mirrored pair to a write consistency group?
 - **Yes** – Select the **Add to consistency group** check box.
 - **No** – Go to step 7.
7. Click **OK**.

The Change Write Mode confirmation message appears.

8. Click **Yes**.

The Mirroring properties section on the Properties pane in the Array Management Window for the local storage array shows the following information:

- The mirror status is Synchronized.
- The write mode is either synchronous or asynchronous.
- The secondary volume is either write consistent or not write consistent.
- The Resynchronization method is either manual or automatic.

Resynchronizing Volumes in a Remote Volume Mirror

There are two resynchronization methods:

- **Manual resynchronization** – Go to [Manually Resynchronizing Volumes in a Remote Volume Mirror](#).
- **Automatic resynchronization** – Go to [Automatically Resynchronizing Volumes in a Remote Volume Mirror](#).

For more information about synchronization and resynchronization in remote volume mirrors, go to these topics:

- [Normally Synchronized Volumes in a Remote Volume Mirror](#)
- [Unsynchronized Volumes in a Remote Volume Mirror](#)
- [Setting the Synchronization Priority and the Synchronization Method](#)
- [Changing the Synchronization Priority and the Synchronization Method of a Remote Volume Mirror](#)
- [Resynchronizing Volumes in a Remote Volume Mirror](#)

You might need to periodically test the communication between the primary volume and the secondary volume in a remote volume mirror, especially after resynchronizing the volumes. For more information, go to [Testing Communication Between the Primary Volume and the Secondary Volume in a Remote Volume Mirror](#).

Changing the Synchronization Priority and the Synchronization Method of a Remote Volume Mirror

The synchronization priority defines how much processing time and resources are allocated to synchronizing the primary volume and the secondary volume of a remote volume mirror relative to system performance. Increasing the synchronization priority of a remote volume mirror might degrade system performance. You can set the synchronization priority for a remote volume mirror at any time. Synchronization priorities can affect these operations:

- Performing a copyback
- Performing a Dynamic Volume Expansion (DVE)
- Reconstructing a volume
- Initializing a volume
- Changing the segment size of a volume
- Defragmenting a volume group
- Adding free capacity to a volume group
- Changing the RAID level of a volume group

To change the synchronization priority and the synchronization method after a remote volume mirror was created, perform these steps:

1. In the Array Management Window of the storage array that contains the primary volume of the mirrored pair, right-click the **Logical** tab.
2. Select **Change >> Synchronization Settings**.

The **Change Synchronization Settings** dialog appears.

3. In the Mirrored pairs table, select the primary volume and the remote volume for which to change the synchronization priority. To select all volumes, click **Select All**.

4. On the **Select Synchronization Priority** slide bar, select the synchronization priority for the mirrored pair.
5. Select either **Manual resynchronization** or **Automatic resynchronization**.
 - **Automatic resynchronization** – Resynchronization starts immediately after communication is restored between unsynchronized mirrored volumes.
 - **Manual resynchronization** – The mirrored pair must be manually resynchronized each time communication is restored between unsynchronized mirrored volumes.
6. Click **OK**.

The Change Synchronization Settings confirmation message appears.
7. Click **Yes**.

The Change Synchronization Priority - Progress bar shows the progress of the resynchronization priority change process for a remote volume mirror.
8. Click **OK**.

Normally Synchronized Volumes in a Remote Volume Mirror

In a normally synchronized remote volume mirror, controller owners manage the transfer of data from the primary volume to the secondary volume. In a normal remote volume mirror, these events happen:

1. The primary volume receives a write request from a host.
2. The controller owner on the storage array logs information about the write operation to a mirror repository volume in the storage array.
3. The controller owner writes the data to the primary volume.
4. The controller owner starts a data transfer operation to the secondary volume on the secondary storage array.

The communication between a primary volume and a secondary volume can be either suspended or become unsynchronized. If the communication between the primary volume and the secondary volume breaks, these events happen:

1. The status of the mirrored pair changes to Unsynchronized.
2. A Needs Attention status appears for the storage array.
3. Data is written to the primary volume.
4. Write requests to the primary volume are logged.
5. The controller owner sends an I/O completion to the host sending the write request. Although the host can continue to send write requests to the primary volume, no data transfer takes place to the secondary volume. Writes to the secondary volume are suspended pending the restoration of communications between the primary volume and the secondary volume.

When connectivity is restored between the primary volume and the secondary volume, the mirrored pair is ready to be resynchronized.



NOTE When the primary volume and the secondary volume are resynchronized, only data that has changed on the primary volume after the break in communication is transferred to the secondary volume.



ATTENTION Possible loss of data – If communication is broken after resynchronization starts between the primary storage array and the secondary storage array, the new data might mix with the old data on the secondary volume and render the data unusable in a disaster recovery situation.

Unsynchronized Volumes in a Remote Volume Mirror

The communication between a primary volume and a secondary volume can either be suspended or become unsynchronized. If the communication between the primary volume and the secondary volume breaks, these events occur:

1. The status of the mirrored pair changes to Unsynchronized.
2. A Needs Attention status appears for the storage array.
3. Data is written to the primary volume.
4. Write requests to the primary volume are logged.
5. The controller owner sends an I/O completion to the host sending the write request. Although the host can continue to send write requests to the primary volume, no data transfer takes place to the secondary volume. Writes to the secondary volume are suspended pending the restoration of communications between the primary volume and the secondary volume.

When connectivity is restored between the primary volume and the secondary volume, the mirrored pair is ready to be resynchronized.



NOTE When the primary volume and the secondary volume are resynchronized, only data that has changed on the primary volume after the break in communication is transferred to the secondary volume.



ATTENTION Possible loss of data – If communication is broken after resynchronization starts between the primary storage array and the secondary storage array, the new data might mix with the old data on the secondary volume and render the data unusable in a disaster recovery situation.

For more information about synchronization and resynchronization in remote volume mirrors, go to these topics:

- [Normally Synchronized Volumes in a Remote Volume Mirror](#)
- [Setting the Synchronization Priority and the Synchronization Method](#)
- [Changing the Synchronization Priority and the Synchronization Method of a Remote Volume Mirror](#)
- [Resynchronizing Volumes in a Remote Volume Mirror](#)
- [Manually Resynchronizing Volumes in a Remote Volume Mirror](#)
- [Automatically Resynchronizing Volumes in a Remote Volume Mirror](#)

You might need to periodically test the communication between the primary volume and the secondary volume in a remote volume mirror, especially after resynchronizing the volumes. For more information, go to [Testing Communication Between the Primary Volume and the Secondary Volume in a Remote Volume Mirror](#).

Automatically Resynchronizing Volumes in a Remote Volume Mirror

When automatic resynchronization is selected, the controller owner of the primary volume automatically starts resynchronizing the data on the remote volume mirror pair immediately after communication is restored between the primary volume and the remote volume.



ATTENTION Possible loss of data – If a resynchronization is interrupted while in progress, another resynchronization automatically starts immediately after communication is restored between the primary volume and the remote volume, which could destroy data integrity.

With automatic resynchronization, you cannot add a secondary volume to a write consistency group; therefore, write consistency during the resynchronization process is not preserved. The write order is not consistent until the entire write consistency group achieves Optimal status. When the write consistency group is in an Optimal state, consistency is achieved.

- For more information about synchronization and resynchronization go to these topics:
 - [Normally Synchronized Volumes in a Remote Volume Mirror](#)
 - [Unsynchronized Volumes in a Remote Volume Mirror](#)
 - [Setting the Synchronization Priority and the Synchronization Method](#)
 - [Changing the Synchronization Priority and the Synchronization Method of a Remote Volume Mirror](#)
 - [Resynchronizing Volumes in a Remote Volume Mirror](#)
 - [Manually Resynchronizing Volumes in a Remote Volume Mirror](#)
- You might need to periodically test the communication between the primary volume and the secondary volume in a remote volume mirror, especially after resynchronizing the volumes. For more information, go to [Testing Communication Between the Primary Volume and the Secondary Volume in a Remote Volume Mirror](#).

Manually Resynchronizing Volumes in a Remote Volume Mirror

When manual resynchronization is selected, you must manually resynchronize and resume the data transfer on a remote volume mirror after communication is restored between the primary volume and the remote volume. Manual resynchronization is the recommended setting for all remote volume mirrors for three reasons:

- You determine when resynchronization starts, so you can manage the process to mitigate the potential impact on I/O performance.
- In a disaster recovery situation, manual resynchronization offers the best chance of retrieving valid data.
- When the secondary volume is in a write consistency group, manual resynchronization preserves the write order.

For more information about synchronization and resynchronization in remote volume mirrors, go to these topics:

- [Normally Synchronized Volumes in a Remote Volume Mirror](#)
- [Unsynchronized Volumes in a Remote Volume Mirror](#)
- [Setting the Synchronization Priority and the Synchronization Method](#)
- [Changing the Synchronization Priority and the Synchronization Method of a Remote Volume Mirror](#)
- [Resynchronizing Volumes in a Remote Volume Mirror](#)
- [Automatically Resynchronizing Volumes in a Remote Volume Mirror](#)

You might need to periodically test the communication between the primary volume and the secondary volume in a remote volume mirror, especially after resynchronizing the volumes. For more information, go to [Testing Communication Between the Primary Volume and the Secondary Volume in a Remote Volume Mirror](#).

Reversing the Roles of the Primary Volume and the Secondary Volume in a Remote Volume Mirror

If the primary volume in a remote volume mirror fails in a disaster situation, you can reverse the roles of the primary volume and the secondary volume to transfer the data back to the restored volume. Reversing the roles promotes the secondary volume to the role of primary volume and demotes the primary volume to the role of secondary volume in a remote volume mirror.



ATTENTION Potential loss of data access – If you try to reverse roles between the secondary volume and the primary volume while a volume copy is in progress, the role reversal succeeds, but the volume copy fails and cannot be restarted.



IMPORTANT You cannot perform a volume copy on a secondary volume in a remote volume mirror. To create a volume copy of a secondary volume, you must reverse the roles of the secondary volume and the primary volume, and then perform the volume copy on the new primary volume.



NOTE While a remote volume mirror is synchronizing, you cannot perform a volume copy on either the primary volume or the secondary volume.



NOTE If you reverse roles between a secondary volume with less capacity than the primary volume has, the role reversal succeeds, but the usable capacity of the new secondary volume (the original primary volume) equals the total capacity of the new primary volume (the original secondary volume).

Promoting the Secondary Volume or Demoting the Primary Volume in a Remote Volume Mirror

You can either promote the secondary volume to the role of primary volume, or you can demote the primary volume to the role of secondary volume.

1. In the Array Management Window of the storage array that contains the volume you are changing, click the **Logical** tab.
2. Right-click the volume you are changing.



NOTE The primary volume can be on the remote storage array, and the secondary volume can be on the local storage array.

- **Promoting the secondary volume to the role of primary volume** – Select **Change >> Role to Primary**. The **Change to Primary** message appears. Click **Yes**. The roles of the primary volume and the secondary volume are reversed.
- **Demoting the primary volume to the role of secondary volume** – Select **Change >> Role to Secondary**. The **Change to Secondary** message appears. Click **Yes**. The roles of the primary volume and the secondary volume are reversed.

Suspending a Remote Volume Mirror

1. In the Array Management Window of the storage array with the primary volume, select the **Logical** tab.
2. In the Logical pane, right-click the primary volume of a mirrored pair, and select **Suspend Mirroring**.

The **Suspend Mirrored Pair** dialog appears. The Mirrored pairs table shows all mirrored pairs in the local storage array and in the remote storage array.

3. Select one or more mirrored pairs to suspend. To select all mirrored pairs, click **Select All**.
4. Click **Suspend**.

The Suspend Mirror Relationship - Confirmation message appears.

5. In the text box, type *Yes*, and click **OK**.

The Suspend Mirrored Pair - Progress bar shows the progress of the suspension.

6. Click **OK**.

The Properties pane in the Array Management Window that contains the suspended primary volume shows the Mirror status as Suspended. The Suspended icon appears next to the primary volume icon and the secondary volume icon in the Logical pane in the Array Management Window.

About Resumed Remote Volume Mirrors

When a remote volume mirror is suspended, data continues to read to the primary volume, but the data is not written to the secondary volume. Writes to the primary volume are persistently logged in to the mirror repository volumes.

After communications are restored in a remote volume mirror, data transfer between the primary volume and the secondary volume must be resynchronized.

- **Automatic resynchronization** – The data transfer automatically starts immediately after the volumes are resynchronized.
- **Manual resynchronization** – You must manually resume the remote volume mirror to restart the data transfer. A suspended remote volume mirror stays in a Suspended status until it is manually resumed.

After the remote volume mirror resumes, data is automatically written to the secondary volume. Only the regions of the primary volume that changed since the mirrored pair was suspended are written to the secondary volume



ATTENTION Possible loss of data access – When you resume a remote volume mirror when either the primary volume or the secondary volume is a member of a write consistency group, all other suspended remote volume mirrors for mirrored pairs in the write consistency group also resume.



NOTE When the write mode is synchronous, you do not need to resynchronize the primary volume and the secondary volume after you resume the remote volume mirror.

Resuming a Remote Volume Mirror

1. In the Array Management Window of the storage array with the primary volume, select the **Logical** tab.
2. In the Logical pane, right-click the primary volume of the mirrored pair, and select **Resume Mirroring**.

The **Resume Mirrored Pair** dialog appears. The Mirrored pairs table shows all suspended mirrored pairs in the local storage array and in the remote storage array.

3. Select one or more mirrored pairs. To select all mirrored pairs, click **Select All**.
4. Click **Resume**.

The Resume Mirrored Pair - Confirmation message appears.

5. Click **Yes**.

The remote volume mirror resumes. The Properties panes in the Array Management Windows for the local storage array and the remote storage array show the mirror status as Synchronized for both the primary volume and the secondary volume.

Testing Communication Between the Primary Volume and the Secondary Volume in a Remote Volume Mirror

You might need to test the communication between the primary volume and the secondary volume in a remote volume mirror. This situation applies especially when the resynchronization method is manual or during a disaster recovery scenario. For more information about synchronization and resynchronization in remote volume mirrors, go to these topics:

- [Normally Synchronized Volumes in a Remote Volume Mirror](#)
- [Unsynchronized Volumes in a Remote Volume Mirror](#)
- [Setting the Synchronization Priority and the Synchronization Method](#)
- [Changing the Synchronization Priority and the Synchronization Method of a Remote Volume Mirror](#)
- [Resynchronizing Volumes in a Remote Volume Mirror](#)
- [Automatically Resynchronizing Volumes in a Remote Volume Mirror](#)

To test the communication between volumes in a remote volume mirror, perform these steps:

1. In the Array Management Window of either the primary volume or the secondary volume, select the **Logical** tab.
2. In the Logical pane, right-click the volume.
3. Select **Test Mirror Communication**.

The Mirror Communication Test Progress message appears.



IMPORTANT This process might take a while to complete.

Deleting a Volume from a Mirrored Pair in a Storage Array

You can delete either a primary volume, a secondary volume, or both volumes from a mirrored pair in a storage array.

 **ATTENTION** Do not remove a mirror relationship to back up a mirrored volume. To perform backups of either the primary volume or the secondary volume, suspend the remote volume mirror so that the mirror relationship is not broken.

Deleting a Primary Volume in a Mirrored Pair from a Storage Array

 **ATTENTION Possible loss of data** – Depending on which premium features are enabled on the storage array, deleting a primary volume might delete all associated volumes, which can result in the permanent loss of the data on those volumes.

 **IMPORTANT** You cannot delete a primary volume while it is synchronizing.

When you delete a primary volume from a remote volume mirror, these events occur:

- The primary volume is deleted from the storage array.
-

 **ATTENTION Loss of data** – The volume is permanently deleted from the storage array, and all data on the primary volume is permanently lost.

- The mirror relationship breaks.
- The capacity of the deleted volume becomes unconfigured free capacity in the storage array and is available for creating new volumes.
- The secondary volume becomes a regular, standard volume and is able to accept both reads and writes.

To delete a primary volume in a mirrored pair from a storage array, perform these steps:

1. Stop all I/O activity to the primary volume, and unmount any file systems on the primary volume.
2. In the Array Management Window of the storage array that contains the primary volume, select the **Logical** tab.
3. In the Logical pane, right-click the primary volume, and select **Delete**.
The **Delete Volumes** dialog appears.
4. Select one or more volumes to delete, and click **Delete**.
The Confirm Delete Volume(s) message appears
5. In the text box, type **Yes**, and click **OK**.
The Delete Volumes - Progress bar appears.
6. When the deletion is complete, click **OK**.

The primary volume is deleted from the storage array. The secondary volume in the mirrored pair is a regular standard volume in the storage array.

 **ATTENTION Loss of data** – The primary volume is permanently deleted from the storage array, and all data on the volume is permanently lost.

Deleting a Secondary Volume in a Mirrored Pair from a Storage Array

 **ATTENTION Possible loss of data** – Depending on which premium features are enabled on the storage array, deleting a secondary volume might delete all associated volumes, which can result in the permanent loss of the data on those volumes.

 **IMPORTANT** You can delete a secondary volume while it is synchronizing.

When you delete a secondary volume, the mirror relationship is removed, and the remote volume mirror is destroyed.

 **ATTENTION Possible loss of data** – Deleting a secondary volume results in the permanent loss of the data on the secondary volume.

To delete a primary volume in a mirrored pair from a storage array, perform these steps:

1. Stop all I/O activity on the secondary volume, and unmount any file systems on the secondary volume.
2. In the Array Management Window of the storage array that contains the secondary volume, select the **Logical** tab.
3. In the Logical pane, right-click the secondary volume, and select **Delete**.

The Delete Volumes dialog appears.

4. Select one or more volumes to delete, and click **Delete**.

The Confirm Delete Volume(s) message appears.

5. In the text box, type **Yes**, and click **OK**.

The Delete Volumes - Progress bar appears.

6. When the deletion is complete, click **OK**.

The mirror relationship is removed, and the remote volume mirror is destroyed.

 **ATTENTION Loss of data** – The secondary volume is deleted, and the data on the secondary volume is permanently destroyed.

Removing a Remote Volume Mirror from a Storage Array

Removing a remote volume mirror from a storage array returns both the primary volume and the secondary volume to regular standard volumes. Normal I/O operations continue on the former primary volume. The former secondary volume is available for normal I/O operations. Both volumes are read-write enabled. A mirror relationship between the two volumes can be re-created unless one of the volumes has been deleted.



ATTENTION Possible loss of data access – Do not remove a mirror relationship to back up a mirrored volume. To back up either the primary volume or the secondary volume, suspend the remote volume mirror so that the mirror relationship is not broken.



NOTE No data on either volume is deleted.

-
1. In the Array Management Window of the storage array that contains the primary volume, select the **Logical** tab.
 2. In the Logical pane, right-click the primary volume of a mirrored pair, and select **Remove Mirror Relationship**.
The **Remove Mirror Relationship** dialog appears. The Mirrored pairs table shows all mirrored pairs in the local storage array and in the remote storage array.
 3. Select one or more mirrored pairs for which to remove the relationship. To select all mirrored pairs, click **Select All**.
 4. Click **Remove**.
The Remove Mirror Relationship - Confirmation message appears.
 5. Click **Yes**.
The Remove Mirrored Pair - Progress bar shows the progress of the removal process.

Disabling the Remote Volume Mirroring Premium Feature

Before you can disable the Remote Volume Mirroring premium feature, the Remote Volume Mirroring premium feature must have been deactivated on the storage array.

Deleting the Remote Volume Mirroring premium feature on this storage array does not affect remote volume mirrors or the Remote Volume Mirroring premium features of other storage arrays; however, another storage array cannot use this storage array as a remote storage array for creating a remote volume mirror.



NOTE To enable the Remote Volume Mirroring premium feature again, you must either retrieve the Remote Volume Mirroring premium feature key or obtain a new one from your Customer and Technical Support representative.

-
1. In the Array Management Window, select **Storage Array >> Remote Volume Mirroring >> Deactivate**.

The Deactivate Remote Volume Mirroring confirmation message appears.

2. Click **Yes**.

The Remote Volume Mirroring premium feature is deactivated, and the two mirror repository volumes are deleted from the storage array.

Deactivating the Remote Volume Mirroring Premium Feature

Before you can deactivate the Remote Volume Mirroring premium feature, all remote volume mirrors must have been deactivated on the storage array.

After you have deactivated the Remote Volume Mirroring premium feature, you cannot create any more remote volume mirrors on the storage array.

Deleting the Remote Volume Mirroring premium feature on this storage array does not affect remote volume mirrors or the Remote Volume Mirroring premium features of other storage arrays; however, another storage array cannot use this storage array as a remote storage array for creating a remote volume mirror.

1. In the Array Management Window, select **Storage Array >> Remote Volume Mirroring >> Deactivate**.

The Deactivate Remote Volume Mirroring confirmation message appears.

2. Click **Yes**.

The Remote Volume Mirroring premium feature is deactivated, and the two mirror repository volumes are deleted from the storage array.

Volume Copy Premium Feature

This topic describes how to obtain, activate, and use the Volume Copy premium feature for SANtricity ES Storage Manager Version 10.75.

About the Volume Copy Premium Feature

The Volume Copy premium feature enables you to create a point-in-time copy of a volume by creating two separate volumes, the source volume and the target volume, on the same storage array. Volume Copy performs a byte-by-byte copy from the source volume to the target volume; therefore, the data on the target volume is identical to the data on the source volume. For more information about the Volume Copy premium feature, go to these topics:

- [Components of the Volume Copy Premium Feature](#)
- [Improve Storage Array Performance](#)
- [Expand Storage Capacity](#)
- [Create Data Backup Volumes](#)

Components of the Volume Copy Premium Feature

The Volume Copy premium feature includes these components:

- The Create Copy wizard, which guides you through these steps in creating a Volume Copy:
 - a. Selecting a source volume from a list of available volumes
 - b. Selecting a target volume from a list of available volumes
 - c. Setting the copy priority for the volume copy
- The Copy Manager, where you can perform these actions:
 - Monitor the progress of a volume copy
 - Stop a volume copy
 - Recopy a volume copy
 - Remove copy pairs
 - Change target volume permissions
 - Change copy priority

Improve Storage Array Performance

Volume Copy enables you to improve storage array performance in these ways:

- Obtain better performance by moving data to drives with higher transfer rates.
- Obtain better performance by moving data to drives with newer technologies.

Expand Storage Capacity

As your storage requirements change, you can use the Volume Copy premium feature to expand storage capacity.

- Move data to volume groups with larger-capacity drives.
- Move data to a volume in a volume group within the same storage array with larger-capacity drives.
- Move data to volume groups that use larger-capacity drives within the same storage array.

Create Data Backup Volumes

With Volume Copy, you can create a backup of a volume by copying data from one volume to another volume in the same storage array. You can use the target volume as a backup for the source volume, for system testing, or to back up to another device, such as a tape drive.

Obtaining the Volume Copy Premium Feature Key

Before you can create a volume copy, you must obtain the Volume Copy premium feature key and enable the premium feature. If you have purchased the Volume Copy premium feature, contact your Customer and Technical Support representative to obtain the premium feature key.

The Customer and Technical Support representative will need the 30-character string in the Feature Enable Identifier field in the **Premium Features and Feature Pack Information** window in Array Management Window of the storage array.

To obtain the Volume Copy premium feature, perform these steps:

1. In the Array Management Window, select **Storage Array >> Premium Features**.

The **Premium Features and Features Pack** dialog opens and shows a list of premium features installed on the storage array.

2. Find and record the 30-character string in the Feature Enable Identifier field.

The Customer and Technical Support representative uses the Feature Enable Identifier to generate the premium feature key.

3. Copy the Volume Copy premium feature key to a directory from which you can retrieve it when you are ready to enable the premium feature.

The default directory is `C:\Documents and Settings\My Documents`.

Enabling the Volume Copy Premium Feature

After you have obtained the Volume Copy premium feature key, perform these steps to enable the Volume Copy premium feature:

1. On the menu bar in the Array Management Window, select **Storage Array >> Premium Features**.
The **Premium Features and Features Pack** dialog opens and shows a list of premium features installed on the storage array.
2. Select **Volume Copy**, and click **Enable**.
The `My Documents` directory appears.
3. Is the Volume Copy premium feature key in the `My Documents` directory?
 - **Yes** – Go to step 5.
 - **No** – Navigate to the appropriate directory.
4. Select the Volume Copy premium feature key file, and click **OK**.
The Enable Premium Features confirmation message appears.
5. Click **Yes**.
The Premium Features installed on storage array list shows Volume Copy as enabled.

Volume Copy States

In a volume copy, each copy relationship maintains its state independently. The available volume copy states follow:

- **Halted** – The initial state of a volume copy request. No data is moving between the source volume and the target volume. The source volume can accept I/O requests. The target volume can accept read requests. Based on its permission levels, the target volume can either accept or reject I/O requests.
- **Copy-Pending** – A volume copy operation was requested but has not yet started. Both the source volume and the target volume reject I/O requests.
- **Copy-in-Progress** – Data is being copied from the source volume to the target volume. Both the source volume and the target volume reject I/O requests.
- **Copy Failed** – Data copying between the source volume and the target volume has stopped. Host I/O requests are rejected.
- **Complete** – After the copy operation is complete, all data has been transferred from the source volume to the target volume. Source I/O requests are available. Based on its permission levels, the target volume can either accept or reject I/O requests.

Input/Output Performance During a Volume Copy Operation

During a volume copy operation, data is read from the source volume and written to the target volume in the same storage array. Because the volume copy operation diverts controller processing resources from normal I/O activity, I/O activity in the storage array can become degraded. You can use the volume copy modification priority feature to designate how much processing time is allocated for a volume copy operation compared to normal I/O activity. For more information, go to these topics:

- [System Performance Factors](#)
- [Copy Modification Priority Setting](#)
- [Copy Modification Priority Rate](#)

System Performance Factors

These factors contribute to system performance:

- I/O activity
- Volume RAID level
- Volume configuration – The number of drives in the volume group or cache parameters
- Volume type – Snapshot volumes might take more time to copy than standard volumes

Copy Modification Priority Setting

The copy modification priority setting balances I/O activity with volume copy activity on a storage array. You can select the copy modification priority while you are creating a new volume copy, or you can change it later by using the Copy Manager.

- Higher volume copy priorities allocate more resources to the volume copy operation and might degrade I/O performance.
- Lower volume copy priorities allocate fewer resources to the volume copy operation and have less impact on normal I/O performance.

Copy Modification Priority Rate

Five copy modification priority rates are available:

- Lowest
- Low
- Medium
- High
- Highest

I/O activity is prioritized, and the volume copy takes longer, when the copy modification priority is set to the lowest priority rate. When the volume copy is prioritized, I/O activity for the storage array might be affected.

Volume Copy Restrictions

The maximum allowable number of volume copies in a storage array depends on the number of target volumes that are available on the storage array. For more specific information about volume copy restrictions, go to the following topics:

- [Read/Write Restrictions](#)
- [Source Volume Restrictions](#)
- [Target Volume Restrictions](#)

Read/Write Restrictions

During a volume copy operation, the source volume rejects write requests. After a volume copy operation is finished, the copy request can be removed.

- All information about the state of the volume copy is lost.
- I/O restrictions are removed.
- Both the source volume and the target volume can accept read requests and write requests.

Source Volume Restrictions

You can use these types of volumes as source volumes:

- A standard volume
- A snapshot volume
- The source volume of a snapshot volume
- The primary volume in a remote volume mirror

You cannot use these types of volumes as source volumes:

- The secondary volume in a remote volume mirror
- A volume currently in a modification operation
- A volume that is reserved by the host

You cannot use volumes in these statuses as source volumes:

- A source volume or a target volume in another volume copy that is in either a Failed status, and In Progress status, or a Pending status
- A volume in a Failed status
- A volume in a Degraded status

Target Volume Restrictions

You can use a volume as a target volume in only one volume copy at a time. The capacity of the target volume must be equal to or greater than the usable capacity of the source volume. You can use these types of volumes as target volumes:

- A standard volume
- The source volume of a disabled or a failed snapshot volume

- The primary volume in a remote volume mirror

Volume Copy and Data Assurance Restrictions

Volume Copy operations are allowed based on Data Assurance attributes when the Data Assurance premium feature is enabled on the storage array. When a volume to be copied is Data Assurance protected, the target volume also should be, but is not required to be, protected. Protection information is supplied and checked for the source volume and the target volume in the following manner:

- **Both the source volume and the target volume are Data Assurance protected –**
 - All protection information fields are verified when reading data from the source volume. The **Guard Tag** field and the **Reference Tag** field are propagated from the source volume to the target volume.
 - The fields are then verified when writing data to the target volume. The application target value provided by the source volume is verified, and then it is replaced by the value associated with the target volume as the data is transmitted to the target volume.

 **IMPORTANT** In this case, the I/O controller must be able to verify and replace the Application Tag on the fly.

- **The source volume is Data Assurance protected, but the target volume is not Data Assurance protected –** Protection information is verified as the data is read from the source volume. Protection information is then verified and removed as the data is written to the target volume.
- **The target volume is Data Assurance protected, but the source volume is not Data Assurance protected –** Data Assurance information is inserted as data is written to the target volume.

Allowable Volume Copy Operations

| Volume Data Assurance Attributes | | | | Volume Copy Operation Allowed | Application Tag Notes | |
|----------------------------------|------------|------------------------|------------|-------------------------------|-------------------------------|-------------------------------|
| Source Volume | | Target Volume | | | Source Application Tag Source | Target Application Tag Source |
| Data Assurance Enabled | ATO | Data Assurance Enabled | ATO | | | |
| No | N/A | No | N/A | Yes | | |
| No | N/A | Yes | Controller | Yes | | |
| No | N/A | Yes | Host | Yes | | |
| Yes | Controller | No | N/A | Yes | Source default | |
| Yes | Host | N/A | N/A | Yes | Host Application Tag | |
| Yes | Controller | Yes | Controller | Yes | Source Default | Source Application Tag |
| Yes | Controller | Yes | Host | No | | |
| Yes | Host | Yes | Controller | No | | |

| Volume Data Assurance Attributes | | | | Volume Copy Operation Allowed | Application Tag Notes | |
|----------------------------------|------|------------------------|------|-------------------------------|-------------------------------|-------------------------------|
| Source Volume | | Target Volume | | | Source Application Tag Source | Target Application Tag Source |
| Data Assurance Enabled | ATO | Data Assurance Enabled | ATO | | | |
| Yes | Host | Yes | Host | Yes | Host Application Tag | Source Application Tag |

 **NOTE** Application Tag Ownership (ATO) shows whether the portion of the Data Assurance information that is the application tag is owned by the controllers and should be validated for correctness.

Volume Copy and Snapshot Volumes

These topics describe how Volume Copy works with snapshot volumes.

Designating a Source Volume of a Snapshot Volume as the Target Volume of a Volume Copy

To designate the source volume of a snapshot volume as the target volume of a volume copy, you must disable all snapshot volumes that are associated with the source volume before you can select it as a target volume. If any snapshot volumes are associated with the target volume, the volume copy operation fails all of the associated snapshot volumes.

Restoring Data to a Source Volume from its Associated Snapshot Volume

To restore data to a source volume from its associated snapshot volume, use Volume Copy to copy data from the snapshot volume back to the source volume.



ATTENTION Possible loss of data access – If you are using the Windows 2000 operating system or the Linux operating system, use Volume Copy with the Snapshot Volume premium feature to restore snapshot volume data to the source volume. Otherwise, the source volume and the target volume can become inaccessible to the host.

To restore the data to the source volume, perform these steps:

1. Create a volume copy of the snapshot volume, and copy the data from the snapshot volume to the target volume of the volume copy.
 2. Copy the data from the target volume back to the source volume.
-



NOTE Another method for producing a copy of the secondary volume is to create a snapshot volume of the secondary volume, and then perform a volume copy operation on the snapshot volume.

Volume Copy and Journaling File System Formatting

If the source volume was formatted with a journaling file system, the storage array might reject a read request to the source volume, and an error message might appear. The journaling file system driver issues a write request before it tries to issue the read request. The controller rejects the write request. This situation might result in an error message that states that the source volume is write protected.

- To prevent rejected write requests, do not try to access a source volume that is participating in a volume copy operation while it is in an In Progress status.
- To prevent an error message from appearing, make sure that the read-only permission for the target volume is disabled after the volume copy has finished.

Creating a Volume Copy

Before you can create a volume copy, the premium feature must be enabled on the storage array. When you create a volume copy, make sure that the capacity of the target volume is equal to or greater than the capacity of the source volume.



ATTENTION Potential loss of data – A volume copy overwrites all existing data on the target volume, automatically makes the target volume read-only to the hosts, and fails all snapshot volumes that are associated with the target volume.

Selecting the Source Volume and the Target Volume in a Volume Copy Pair



IMPORTANT A target volume must have a capacity equal to or greater than the source volume. Only volumes that meet that criteria are candidates to be the target volume.

1. In the Array Management Window, select the **Logical** tab.
2. In the Logical pane, select the volume to copy.
3. On the menu bar, select **Volume >> Copy >> Create**.

The Introduction (Create Copy) wizard appears. The Source volume table shows the available volumes you can select as the source volume. The volume you selected in the Logical pane is highlighted, but you can select any volume in the list.

4. Select the source volume, and click **Next**.

One of these actions occurs:

- When one or more volumes meet the criteria to be a target volume, the Target volume table appears.
- If no volumes meet the criteria to be a target volume, the No Target Volume Candidates Found message appears. Click **OK** to return to the Source volume table, and select another source volume.

5. In the Target volume table, select the target volume.
6. On the **Select copy priority** slide bar, select the priority for allocating system resources to the copy operation, and click **Next**.

The Preview (Create Copy) wizard appears.

7. In the text box, type **Yes** to confirm starting the copy operation, and click **Finish**.

- The volume copy starts, and data is read from the source volume and written to the target volume.
- In the Logical pane in the Array Management Window, Operation in Progress icons appear on the source volume and the target volume and show that the volume copy is in either a Pending status or an In Progress status.
- After the copy operation has finished, the Copy Started (Create Copy) message appears asking whether you want to copy another source volume.

About the Controller Ownership/Preferred Path

During a volume copy, the same controller must own both the source volume and the target volume. If both volumes do not have the same preferred controller when the volume copy starts, the ownership of the target volume is automatically transferred to the preferred controller of the source volume.

- When the volume copy is completed or is stopped, ownership of the target volume is restored to its preferred controller.

- If ownership of the source volume is changed during the volume copy, ownership of the target volume is also changed.

If a controller fails under any of the following conditions, you must manually change controller ownership to the alternate controller to allow the volume copy to finish.

- A volume copy has a status of In Progress.
- The preferred controller of the source volume fails.
- The ownership transfer does not occur automatically during a failover.

 **ATTENTION Possible loss of data** – Verify that either the volumes are not in use or a multi-path driver is installed on the host. If you change the controller ownership/preferred path while an application is using one of the volumes, I/O activity is disrupted, and I/O errors occur unless a multi-path host is installed on the host.

If a multi-path driver is not installed on the host, or if the multi-path driver is not the RDAC multi-path driver, you must make operating system-specific modifications to make sure that the moved volume groups can be accessed on the new path.

After a volume copy has been created, you can change its controller ownership and preferred path settings. Go to [Changing the Controller Ownership/Preferred Path for a Volume Copy](#).

Changing the Controller Ownership/Preferred Path for a Volume Copy

1. In the Array Management Window, select the **Logical** tab.
2. In the Logical pane, select the volume for which to change the controller ownership and preferred path.
3. On the menu bar, select **Volume >> Change >> Ownership/Preferred Path**.
4. Select the available controller.



NOTE A dot identifies the current preferred path and current controller, which are grayed-out and cannot be changed.

The Confirm Change Ownership/Preferred Path message appears.

5. Click **Yes**.

About the Controller Ownership/Preferred Path

During a volume copy, the same controller must own both the source volume and the target volume. If both volumes do not have the same preferred controller when the volume copy starts, the ownership of the target volume is automatically transferred to the preferred controller of the source volume.

- When the volume copy is completed or is stopped, ownership of the target volume is restored to its preferred controller.
- If ownership of the source volume is changed during the volume copy, ownership of the target volume is also changed.

If a controller fails under any of the following conditions, you must manually change controller ownership to the alternate controller to allow the volume copy to finish.

- A volume copy has a status of In Progress.
- The preferred controller of the source volume fails.
- The ownership transfer does not occur automatically during a failover.

 **ATTENTION Possible loss of data** – Verify that either the volumes are not in use or a multi-path driver is installed on the host. If you change the controller ownership/preferred path while an application is using one of the volumes, I/O activity is disrupted, and I/O errors occur unless a multi-path host is installed on the host.

If a multi-path driver is not installed on the host, or if the multi-path driver is not the RDAC multi-path driver, you must make operating system-specific modifications to make sure that the moved volume groups can be accessed on the new path.

After a volume copy has been created, you can change its controller ownership and preferred path settings. Go to [Changing the Controller Ownership/Preferred Path for a Volume Copy](#).

Monitoring the Progress of a Volume Copy in the Copy Manager

You can monitor the progress of a volume copy in the **Copy Manager** only while the volume copy is in a Pending status or in an In Progress status. However, in the storage array profile, you can view both the progress of the volume copy operation and detailed information about all existing volume copies.

- The **Copy Manager** shows all existing copy pairs for all volume copies for the storage array.
- The Status column for the volume copy pair shows the completion percentage of the operation.
- You can stop a volume copy operation while it is in an In Progress status. You can re-copy it later or remove the copy pairs.

For more complete information about the **Copy Manager**, go to [Copy Manager Operations](#).

To open the **Copy Manager**, perform these steps:

1. In the Array Management Window, select the **Logical** tab.
2. On the menu bar, select **Volume >> Copy >> Copy Manager**.

The **Copy Manager** appears.

Viewing Additional Information about a Volume Copy in the Storage Array Profile

In the storage array profile, you can view detailed information about the volumes in a volume copy and the status of the volume copy operation. You can also view detailed information about all existing volume copies in the storage array.

1. In the Array Management Window, select the **Summary** tab.
2. Click **Storage Array Profile**.

The summary page for the storage array appears.

3. Select the **Volumes** tab.

The summary page for the selected volume appears.

4. Select the **Copies** tab.

The summary page for the volume copies appears. The summary page shows detailed information about all existing volume copies in the storage array.

Viewing the Physical Components and Logical Elements of a Source Volume in a Volume Copy

You can view visual representations of the physical components and the logical elements of a source volume in a volume copy.

1. In the Array Management Window, select the **Logical** tab.
2. In the Logical pane, right-click the source volume, and perform either of these actions:
 - **View the associated logical elements of the target volume** – Select **View >> Associated Logical Elements**. The **View Associated Logical Elements** pop-up appears and shows a visual representation of the logical elements of the target volume.
 - **View the associated physical elements of the source volume** – Select **View >> Associated Physical Components**. The **View Associated Physical Components** pop-up appears and shows a visual representation of the physical components of the source volume.

Viewing the Logical Elements of a Target Volume in a Volume Copy

1. In the Array Management Window, select the **Logical** tab.
2. In the Logical pane, right-click the target volume.
3. Select **View >> > Associated Logical Elements**.

The View Associated Logical Elements pop-up appears and shows a visual representation of the logical elements of the target volume.

Copy Manager Operations

You can perform these actions in the **Copy Manager**:

- Restart a volume copy operation that is in a Stopped status. For detailed instructions, go to [Re-Copying a Volume Copy](#).
- Stop a volume copy operation that is in a Pending status or an In Progress status. For detailed instructions, go to [Stopping an In-Progress Volume Copy](#).
- Remove copy pairs that are in a Stopped status or a Completed status. For detailed instructions, go to [Removing a Volume Copy Pair from a Storage Array](#).
- Change the volume copy modification priority settings. You can change these settings while the volume copy is in a Pending status, an In Progress status, or a Stopped status. For detailed instructions, go to [Changing the Modification Priority of a Volume Copy](#).
- Change permissions for a target volume that is in a Completed status or a Stopped status. For detailed instructions, go to [Changing the Target Volume Permissions for a Volume Copy](#).
- Monitor the progress of a volume copy operation while it is in a Pending status or an In Progress status. For detailed instructions, go to [Monitoring the Progress of a Volume Copy in the Copy Manager](#).



NOTE You can also monitor the progress of a volume copy in the storage array profile.

Re-Copying a Volume Copy

You can create a new volume copy from a source volume to its target volume.

- A volume re-copy starts the volume copy again from the beginning.
- You can use the re-copy feature to start a failed volume copy operation or a stopped volume copy operation or to re-copy an already completed volume copy.



ATTENTION Possible loss of data – A volume re-copy operation overwrites existing data on the target volume. If the hosts have been mapped to the source volume, the data that is copied to the target volume when you perform the re-copy operation might have changed since the previous volume copy was created.

To re-copy a completed volume copy, perform these steps:

1. Stop all I/O to the source volume and the target volume.
2. Unmount any file systems on the source volume and the target volume.
3. In the Array Management Window, select the **Logical** tab.
4. On the menu bar, select **Volume >> > Copy >> > Copy Manager**.

The **Copy Manager** appears.

5. In the **Copy Manager**, select the source volume and target volume copy pair.
6. On the menu bar in the **Copy Manager**, select **Copy >> > Re-copy**.

The **Re-Copy** dialog appears. To change the copy priority, move the arrow in the **Copy Priority** slide bar to the left or right.

7. In the text box, type **Yes** to confirm the re-copy operation, and click **OK**.

While a volume re-copy operation is in a Pending status or in an In Progress status, an icon appears next to both the source volume and the target volume.

You can monitor the progress of a volume copy in the **Copy Manager** while a volume copy is in a Pending status or in an In Progress status. For more information, go to [Monitoring the Progress of a Volume Copy in the Copy Manager](#).

You can view more-detailed information in the Storage Array Profile about which volumes are participating in a volume re-copy and the status of the volume re-copy operation. For more information, go to [Viewing Additional Information about a Volume Copy in the Storage Array Profile](#).

Stopping an In-Progress Volume Copy

You can stop an In-Progress volume copy before it has finished.

1. In the Array Management Window, select the **Logical** tab.
2. On the menu bar, select **Volume >> > Copy Manager**.
The **Copy Manager** appears.
3. In the **Copy Manager**, select one or more copy pairs for which to stop the volume copy.
4. On the menu bar in the **Copy Manager**, select **Copy >> > Remove Copy Pairs**.
The **Stop Copy** confirmation message appears.
5. Click **Yes**.
 - The **Copy Manager** shows the status of the volume copy as Stopped.
 - To start a volume copy again, select one or more volume copy pairs, and select **Copy >> > Re-Copy** on the menu bar in the **Copy Manager**.

Removing a Volume Copy Pair from a Storage Array

Removing a volume copy pair breaks the relationship between the source volume and the target volume. After you remove a volume copy pair, you can use the source volume and the target volume again to create new volume copies and new volume copy pairs.



NOTE No data is deleted from either the source volume or the target volume.

After you remove a volume copy pair, these events occur:

- All copy-related attributes of the volume copy pair, including read-only protection, are removed.
- Volume copy information for the volume copy pair is removed from the Volume Properties pane and from the storage array profile.
- The source volume and the target volume no longer appear as a volume copy pair in the **Copy Manager**.

To remove one or more volume copy pairs, perform these steps:

1. In the Array Management Window, select the **Logical** tab.
2. On the menu bar, select **Volume >> Copy >> Copy Manager**.
The **Copy Manager** appears.
3. In the **Copy Manager**, select one or more volume copy pairs to remove.
4. On the menu bar in the **Copy Manager**, select **Copy >> Remove Copy Pairs**.
The Remove Copy Pairs confirmation message appears.
5. Click **Yes**.
The Remove Copy Pairs - Progress bar shows the progress of the removal operation.
6. Click **OK**.

Changing the Modification Priority of a Volume Copy

The modification priority defines how much processing time and resources are allocated to volume copy modifications compared with system performance. Increasing the modification priority of a volume copy might degrade system performance. You can set the modification priority of a volume group, and you can change the modification priority of a volume after the volume group has finished. Modification priorities can affect these operations:

- Performing a copyback
- Performing a Dynamic Volume Expansion (DVE)
- Reconstructing a volume
- Initializing a volume
- Changing a volume's segment size
- Defragmenting a volume group
- Adding free capacity to a volume group
- Changing the RAID level of a volume group

To change the modification priority of a volume copy, perform these steps:

1. In the Array Management Window, select the **Logical** tab.
2. In the Logical pane, select the volume for which to change the modification priority.
3. On the menu bar in the Array Management Window, select **Volume >> Change >> Modification Priority**.
 - The **Change Modification Priority** dialog appears.
 - The Select volumes table shows the volumes and the volume groups on the storage array.
 - The **Select Modification Priority** slide bar shows the priority level of the highlighted volume.
4. Select one or more volumes for which to change the modification priority.



NOTE When you select a single volume, the **Select Modification Priority** slide bar shows the priority setting of the volume. When you select multiple volumes, the **Select Modification Priority** slide bar shows the priority setting as Lowest for all volumes, regardless of the actual priority for each individual volume.

- To select nonadjacent volumes, press and hold the **Ctrl** key, and select each volume.
 - To select adjacent volumes, press and hold the **Shift** key, and select each volume.
 - To select all volumes, click **Select All**.
5. On the **Select Modification Priority** slide bar, select the modification priority for the volume or volumes, and click **OK**.

Changing the Target Volume Permissions for a Volume Copy

Read requests and write requests to the target volume do not take place while the volume copy is in either a Pending status or an In Progress status, or if the volume copy fails. After the volume copy operation is complete, the target volume automatically becomes read-only to the hosts.

- To allow changes to the data on the target volume after the volume copy operation is complete, disable the read-only permissions for the target volume.
- To prevent changes to the data on the target volume after the volume copy operation is complete, enable the read-only permissions for the target volume. You should preserve the data on the target volume under the following circumstances:
 - You are using the target volume for backup purposes.
 - You are copying data from one storage array to a larger storage array for greater accessibility.
 - You are using the data on the target volume to copy back to the base volume of a disabled volume or failed flashcopy volume.

To change target volume permissions, perform these steps:

1. In the Array Management Window, select the **Logical** tab.
2. On the menu bar, select **Volume >>Copy >> Copy Manager**.
The **Copy Manager** appears.
3. In the **Copy Manager**, select one or more copy pairs.
4. Select **Change >> Target Volume Permissions**.
5. Perform one of these actions:
 - **Disable Read-Only permissions** – Select **Disable Read-Only**. Read-write permissions are enabled on the target volume and are automatically available to hosts after the volume copy has finished.
 - **Make the target volume read-only to hosts** – Select **Read-Only**. Read-only permissions are enabled on the target volume. Write requests to the target volume are rejected even after the volume copy has finished.

Obtaining the Volume Copy Premium Feature Key

Before you can create a volume copy, you must obtain the Volume Copy premium feature key and enable the premium feature. If you have purchased the Volume Copy premium feature, contact your Customer and Technical Support representative to obtain the premium feature key.

The Customer and Technical Support representative will need the 30-character string in the Feature Enable Identifier field in the **Premium Features and Feature Pack Information** window in Array Management Window of the storage array.

To obtain the Volume Copy premium feature, perform these steps:

1. In the Array Management Window, select **Storage Array >> Premium Features**.

The **Premium Features and Features Pack** dialog opens and shows a list of premium features installed on the storage array.

2. Find and record the 30-character string in the Feature Enable Identifier field.

The Customer and Technical Support representative uses the Feature Enable Identifier to generate the premium feature key.

3. Copy the Volume Copy premium feature key to a directory from which you can retrieve it when you are ready to enable the premium feature.

The default directory is `C:\Documents and Settings\My Documents`.

Disabling the Volume Copy Premium Feature

To disable the Volume Copy premium feature, perform these steps:

1. On the menu bar in the Array Management Window, select **Storage Array >> Premium Features**.

The **Premium Features and Features Pack** window opens and shows a list of premium features installed on the storage array.

2. Select **Volume Copy**, and click **Disable**.

The Disable Premium Features confirmation message appears.

3. Click **Yes**.

The Premium Features installed on storage array list shows Volume Copy as disabled.

4. Click **Close**.

Volume Copy Troubleshooting Tips

Troubleshooting Modification Operations

If you try to create a volume copy at the same time a modification operation is running on either the source volume or the target volume, and the volume copy is in a Pending status, an In Progress status, or a Failed status, the volume copy cannot start.

If a modification operation is running on a source volume or a target volume after a volume copy has been created, the modification operation must complete before the volume copy can start.

While a volume copy is in an In Progress status, no modification operation can take place on either the source volume or the target volume.

Troubleshooting Failed Volume Copy Operations

A volume copy can fail under these conditions:

- A read error from the source volume occurs.
- A write error to the target volume occurs.
- A failure in the storage array occurs that affects the source volume or the target volume, such as a remote volume mirror role reversal.

When a volume copy fails, a critical event is logged in the Event Log, and a Needs Attention icon appears in the Array Management Window.

- When a volume copy is in a Needs Attention status, the host has read-only access to the source volume.
- Read requests from and write requests to the target volume are rejected until the failure is corrected by using the Recovery Guru.

Volume Group Relocation

This document describes these four scenarios for volume group relocation:

- How to move drives to a new storage array for additional capacity (data is not preserved)
- How to export and import a volume group for security (data is preserved)
- How to move a volume group to a different storage array (data is preserved)
- How to move a drive tray to a different storage array (data is preserved)

Understanding Concepts, Restrictions, and Requirements of Volume Group Relocation

The topics in this section provide information you need to plan and prepare for volume group relocation.



ATTENTION Possible hardware damage – To prevent electrostatic discharge damage to the tray, use proper antistatic protection when handling tray components.

Volume Group Relocation



ATTENTION Possible loss of data – If you physically move a storage array or storage array components, you can cause data loss. This loss includes controllers that are not part of a volume group, controller trays that are not part of a volume group, and controller-drive trays or drive trays after they have been installed and configured as part of a volume group.

Use volume group relocation to move drives and drive trays within the same storage array or move them to different storage arrays. The following features of SANtricity ES Storage Manager support volume copy relocation.

- A single, updated configuration database takes advantage of the 512-MB existing DACstore (which provides the foundation needed for logical unit numbers [LUNs] that are larger than 2 TB), RAID Level 6, increased partitions, and drives larger than 2 TB. Additionally, the single, updated configuration database provides a way to manage migration scenarios.
- Exported state, Contingent state, and Forced state are used for various conditions when migrating a volume group from the source storage array to the destination storage array. The Export Volume Group Wizard is used before migrating the volume group from the source storage array. The Import Volume Group Wizard is used after migrating volume groups to the destination storage array. For information, see the topics under “Exporting and Importing a Volume Group.”

A warning message appears when migrating configured volume groups if the number of volumes being added overruns the maximum number of volumes allowed.

Upgrade and Downgrade Restrictions for RAIDCore 1 and RAIDCore 2

RAIDCore 1 does not have an export feature. Therefore, you can remove the drives or place them offline and then remove them from the source storage array. When placing the drives in the destination storage array that supports RAIDCore 2, the drives will appear in the Exported state or the Contingent state. Additionally, the drives will be unusable and will remain in the Exported state or Contingent state until they are imported using the import function.

RAIDCore 2-to-RAIDCore 1 migration is not supported. RAIDCore 1 does not know about RAIDCore 2, and the metadata on the RAIDCore 2 drives has a DACstore number that has a later version so that the drives show up as Unassigned or Failed in RAIDCore 1.

Software Restrictions and Firmware Restrictions

This section describes the supported software versions and firmware versions. This section also describes restrictions that apply to specific versions of the storage management software.

Firmware Requirements for Source Storage Arrays and Destination Storage Arrays

You can manage the source storage array in a volume group relocation procedure with the latest maintenance version of the firmware.

The procedures in these topics were written assuming that the destination storage array is managed with SANtricity ES Storage Manager 10.75 with firmware version 7.75 or later. If the destination storage array is managed with a previous version of the firmware, refer to the *Volume Group Relocation Customer Support Guide* for the previous version.

Persistent Reservations Are Not Preserved in Volumes or Volume Groups (Storage Management Software Version 8.4x and Later)

When you move a volume or a volume group that was configured with a persistent reservation, the reservation information and the registration information are not preserved.

Any reservation information or registration information that exists on a volume or a volume group is automatically deleted when the destination storage array is relocated. For information about persistent reservations, refer to the online help topics in the Array Management Window.

Support for 256 Volumes Per Partition (Storage Management Software Version 8.4x and Later)



IMPORTANT Possible loss of data access – If you try to map a volume to a logical unit number (LUN) that exceeds the restriction on these operating systems, the host is unable to access the volume.

Many hosts are able to have 256 LUNs mapped per storage partition, but the number varies with the type of operating system. Consider if you move a volume or a volume group from a storage array that supports 256 volumes per storage partition to a storage array that does not support 256 volumes. In this case, the host cannot access any volumes that have been mapped to LUNs greater than what the operating system supports. For information about the number of LUNs that are supported by each operating system, refer to the online help topics.

The volume groups or the volumes that are associated with the LUN mappings remain intact. However, the volume groups or the volumes are not available.

To recover from this situation, perform one of these actions:

- If a volume is no longer needed, delete the volume.
- If a LUN is available in the range that the operating system supports, remap the volume to a supported LUN.
- Map the volume to a different storage partition by using a LUN that the operating system supports.

General Restrictions of Volume Group Relocation

Several general restrictions apply that are not based on the controller firmware level or the version of SANtricity ES Storage Manager.

Moving Drive Trays from Multiple Storage Arrays into a Single Storage Array

If you move drive trays from multiple, different storage arrays into a single destination storage array, you must move all of the drive trays from the same storage array as a group into the new destination storage array.

Make sure that all of the drive trays for a single group have been moved to the destination storage array before you move the next group of drive trays.

If the drive trays are not moved as a group to the destination storage array, the newly relocated volume groups might not appear in the Array Management Window.

Moving Drives to a Storage Array with No Current Drive Trays

If you import multiple drives or an entire drive tray into a destination storage array that does not have any drive trays, you must make sure that the power to the controller tray or the controller-drive tray in the destination storage array has been turned off before you attempt the relocation.

After you turn on the power to the destination storage array and it successfully recognizes the newly relocated drives or drive trays, you can add more drives or drive trays without turning off the power to all of the drive trays.

If you move an entire drive tray that has the DC power option, keep in mind that there are special requirements for disconnecting and reconnecting DC power to the drive tray.



WARNING (W14) Risk of bodily injury – A qualified service person is required to make the DC power connection according to NEC and CEC guidelines.

Hitachi Drives Installed in a Just a Bunch of Disks (JBOD) Drive Tray Reports Drives as Missing

If you change tray IDs on Hitachi drives that are installed into a JBOD drive tray, you must restart the system. If you do not restart the system, the tray IDs are *not* added to the loop, and the system reports the drives as missing or absent.

Missing Volumes and Offline Volumes Appear After Volume Group Relocation

If you move volume groups or volumes from one storage array to another, the volumes appear to be absent or can unexpectedly appear Offline.

To prevent this situation, make sure that all of the volumes that you move are taken offline before you try to physically relocate them to the destination storage array.

Excessive Volume Group Relocation



IMPORTANT Do not relocate volume groups and volumes in an excessive manner into the same storage array.

Excessive volume group relocation can be defined as follows: when the total number of volumes on the destination storage array plus the number of volumes that are relocated to the destination storage array exceed the total number of volumes that can be managed by the controllers in the destination storage array.

When excessive volume group relocation occurs, these conditions occur on the destination storage array:

- All pre-existing standard RAID volumes on the destination storage array are kept.
- All standard RAID volumes relocated to the destination storage array are kept.
- If hot volume group relocation occurs, access to pre-existing volumes on the destination storage array is maintained.

If excessive volume group relocation occurs, the volume groups or the volumes that moved to the destination storage array do not appear in the Array Management Window. In addition, they are not shown by the host, even though the definitions are kept in the configuration. Critical Major Event Log (MEL) events are not generated. The Array Management Window does not show that an excess volume group relocation has occurred.

If pre-existing volumes on the destination storage array are deleted, the excess volumes *might* become visible in the Array Management Window, and the excess volumes also become visible to the host. Usually, the status of the excess volumes after they become visible is the same status they had before you moved the excess volumes to the destination storage array. These excess volumes might show a Failed status. You can recover them if you manually put the volume group online in the Array Management Window.

Maximum Number of Drives in a Storage Array

When you relocate drives, volume groups, or drive trays to a destination storage array, make sure that the new configuration does not exceed the maximum number of drives that are supported by the controllers in the destination storage array.

 **ATTENTION Possible data loss or corruption** – If you exceed the number of drives by importing more drives than the storage array supports, data loss or data corruption can occur.

Volumes Might Become Unstable After Drives Have Been Relocated

Volume groups or volumes that are moved from one storage array to the destination storage array can have timing issues.

When you insert drives into the destination storage array, wait at least two minutes before you insert each drive. If you do not wait two minutes, the storage array can become unstable.

Solid State Disk (SSD) Drives

The option to use Solid State Disk (SSD) drives in place of conventional drives is available as a premium feature with some hardware. The FC4600 drive tray and the DE1600 drive tray can have SSD drives. If you relocate a volume group that includes SSD drives, the destination hardware must support those drives.

Drive Firmware Restrictions

Relocation of drives from a drive tray with a 1-Gb/s data transfer rate to a drive tray with a 2-Gb/s data transfer rate is restricted to drives with specific drive firmware levels.

 **ATTENTION Possible data loss or corruption** – Perform a hot volume group relocation whenever possible. This action makes sure that any volume groups or volumes that you move to different destination storage arrays are correctly recognized and managed by the new storage array.

For information about the drive firmware, refer to the [Compatibility Matrix](#), which is available in the LSI Knowledge Database.

Premium Feature Restrictions

Premium features are not in the standard configuration of storage management software. Premium features require a feature key file to enable each specific premium feature. Before you can move volume groups or volumes, you must first enable the required premium features on the destination storage array.

After you move a volume or a volume group that uses premium features to the destination storage array, an Out of Compliance error message might appear. For procedures to correct the error, refer to the Recovery Guru.

The following table lists the premium features that are available for all current releases of the storage management software.

 **NOTE** Support for 256 volumes per partition is not considered a premium feature because this support was introduced as a supported feature in Version 8.40 of the storage management software.

Premium Features Available by Release

| Premium Feature | Release When the Premium Feature Became Available |
|----------------------------------|--|
| Storage Partitioning | All versions of the storage management software |
| Snapshot Volume | SANtricity Storage Manager Version 8.00 |
| Remote Volume Mirroring | SANtricity Storage Manager Version 8.20 (SANtricity Storage Manager Version 9.10 for the SHV2600 controller-drive tray) |
| Volume Copy | SANtricity Storage Manager Version 8.40 |
| SafeStore Drive Security | SANtricity ES Storage Manager Version 10.6 |
| SafeStore Enterprise Key Manager | SANtricity ES Storage Manager Version 10.7 |
| Solid State Disk Support | SANtricity ES Storage Manager Version 10.7 |
| Data Assurance | SANtricity ES Storage Manager Version 10.75 |

Snapshot Volumes (Storage Management Software Version 8.x and Later)

 **IMPORTANT** If you have created a snapshot volume of a base volume, in some cases, the base volume and the snapshot repository volume can reside in different volume groups. If you want to keep the data in the snapshot volume, you must locate and move all of the volume groups that contain snapshot repository volumes that are associated with the snapshot volume. If you do not move all of the associated volumes, the snapshot volume becomes unusable in both the source storage array and the destination storage array.

When you create a snapshot volume, you can allocate capacity for the associated snapshot repository volume in the same volume group as the base volume. You can also use free capacity on a different volume group.

Situations can occur where not all of the associated components of the snapshot volume are moved to the destination storage array, which result in failed volumes or absent volumes. Problems with volume ownership might also occur while you relocate snapshot volume components that are located in different volume groups.

These sections describe the conditions that result when you move volume groups that contain some or all of the snapshot volume components.

Moving All of the Snapshot Volume Components

If you move a volume group that contains all of the snapshot volume information (base volume, snapshot volume, and snapshot repository volume) from the source storage array to a destination storage array, various conditions can occur.



NOTE These conditions also occur when multiple volume groups that contain all of the snapshot volume components are moved at one time.

These conditions occur on the *source* storage array:

- The controller firmware keeps full knowledge of the snapshot volume in the source storage array.
- The base volume and the snapshot repository volumes appear as missing volumes or absent volumes.
- Write requests to the snapshot volume cause the snapshot volume to fail.
- Read requests to the snapshot volume can cause the snapshot volume to fail or can cause the host I/O request to fail.
- If you reinstall the physical drives into the original drive tray, the affected base volume, snapshot volume, and snapshot repository volumes return to the state they were in before the drives were removed.

These conditions occur on the *destination* storage array:

- The controller firmware puts full knowledge of the snapshot volume onto the destination storage array.
- The snapshot volume is set to the same status as it was on the source storage array.

Moving a Base Volume and a Snapshot Volume without the Associated Snapshot Repository Volume

If you move a volume group that contains a base volume and snapshot volume from the source storage array to the destination storage array, various conditions occur.



NOTE In this case, the associated snapshot repository volume stays on the source storage array.

These conditions occur on the *source* storage array:

- The controller firmware keeps full knowledge of the snapshot volume in the source storage array.
- The base volume appears as an absent volume.
- Host I/O requests to the base volume fail.
- Write requests to the snapshot volume can cause the snapshot volume to fail.
- Read requests to the snapshot volume can succeed or can cause the host I/O to fail.

These conditions occur on the *destination* storage array:

- The controller firmware puts full knowledge of the snapshot volume on to the destination storage array.
- The snapshot repository volume appears as an absent volume.
- Write requests to the snapshot volume can cause the snapshot volume to fail.
- Read requests to the snapshot volume can fail the snapshot volume.
- If the snapshot repository volume is added to the system later, the snapshot volume stays failed.

Moving a Snapshot Repository Volume without the Base Volume and the Snapshot Volume

If you move a volume group that contains a snapshot repository volume from the source storage array to a destination storage array, various conditions occur.



NOTE In this case, the associated base volume and the snapshot volumes stay on the source storage array.

These conditions occur on the *source* storage array:

- The controller firmware keeps full knowledge of the snapshot volume in the source storage array.
- The snapshot repository volume appears as an absent volume.
- Host I/O to the base volume is permitted, but writes to the base volume cause the snapshot volume to fail.
- Read requests to the snapshot volume can fail the snapshot volume or can cause the host I/O to fail.
- If the physical drives are replaced into the original drive tray and the snapshot volume remains in an Optimal status, the affected volumes are brought back to the state they were in before the snapshot repository volume was moved. The affected volumes include the base volume, the snapshot volume, and the snapshot repository volume. The snapshot volume becomes fully operational.

These conditions occur on the *destination* storage array:

- The controller firmware puts full knowledge of the snapshot volume onto the destination storage array.
- The base volume and the snapshot volume appear as absent volumes.
- Host I/O requests to the base volume fail in the destination storage array because the base volume is not present.
- Write requests to the snapshot volume can cause the snapshot volume to fail.
- Read requests to the snapshot volume can succeed or can cause the host I/O to fail.

Controller Ownership Changes During Relocation

During the volume group relocation process, you must make sure that controller ownership remains the same for all of the volume groups that contain associated snapshot volume components.

When volume groups are relocated to a different storage array, controller ownership is assigned to controller A by default. If a change in controller ownership occurs on the destination storage array before all of the snapshot volume components are relocated, a dual-controller ownership situation might occur. The situation where neither controller A nor controller B has ownership can also occur.

A change in controller ownership can result from a forced failover or can be the result of a manual change.

For example, a volume group that contains the base volume and the snapshot volume is moved to the destination storage array. The volume group is owned by controller A by default. A forced failover occurs on the destination storage array, which changes the controller ownership of the volume group to controller B. When the volume group that contains the associated snapshot repository volume is moved to the destination storage array, it is owned by controller A by default. This process results in a dual-ownership situation. Both controller A and controller B attempt to assume ownership of all of the snapshot volume components.

To prevent dual-controller ownership or no-controller ownership situations, make sure that the second volume group is not moved to the destination storage array until the controller ownership of the first volume group is changed back to controller A.

After both volume groups are moved, you can change the controller ownership to controller B for all volume groups.

Remote Volume Mirroring (Storage Management Software Version 8.20 and Later)

Before you relocate volumes that participate in a mirror relationship, you must remove the mirror relationship between the primary volume and the secondary volume. This action prevents orphan mirrors on the remote storage array. For instructions about how to remove mirror relationships, refer to the topics under *SANtricity ES Storage Manager Remote Volume Mirroring*, the corresponding PDF document on the SANtricity ES Storage Manager Installation DVD, or the online help topics in the Array Management Window.

If drives that contain mirror repository volumes are moved from a source storage array that is managed by SANtricity Storage Manager 8.20 or later to a destination storage array that is managed by SANtricity Storage Manager 8.00, the mirror repository volumes are not deleted. You must return the drives to the source storage array and deactivate the Remote Volume Mirroring premium feature before you attempt the relocation.

When you move mirror repository volumes from the source storage array to a destination storage array, the mirror repository volume is automatically deleted and cannot be returned to the source storage array.

If the absent volume in the source storage array is deleted and the volume group is reinstalled in the source storage array, the primary volume or the secondary volume appears as a standard volume with no mirroring properties.

Volume Copy (Storage Management Software Version 8.4x and Later)

Before you relocate volume groups that contain volume copies from the source storage array to a destination storage array, make sure that any copy pairs associated with the volumes that you move are removed. You must also make sure that any copy pairs associated with the volumes that you move are removed for a single source volume or a target volume in a copy pair.

For information about how to remove copy pairs, refer to the topics under *SANtricity ES Storage Manager Volume Copy*, the corresponding PDF document on the SANtricity ES Storage Manager Installation DVD, or the online help topics in the Array Management Window.

If a volume group that contains copy pairs is removed and reinstalled into the same storage array for security, you do not need to remove the copy pairs before relocation. In this case, make sure that any volume copies with a status of In Progress or Pending are stopped before you move the volume group. If you perform this check, failure of the volume copies is prevented. For information, see "[Exporting and Importing a Volume Group](#)."

SafeStore Drive Security

SafeStore Drive Security is a premium feature that prevents unauthorized access to the data on a Full Disk Encryption (FDE) drive that is physically removed from the storage array. Controllers in the storage array have a *security key*. Secure drives have hardware support for encryption and decryption and provide secure access to data only through a controller that has the correct security key. All of the controllers in a storage array must have the same security key.

To move security-enabled drives to a new storage array for additional capacity, you can first use the **Secure Erase** option to erase the drives.

To move a volume group that includes a security-enabled volume to a new storage array without loss of data, you must also install the security key from the original storage array into the new storage array. Installing a new security key in a storage array that previously had a different security key might result in data becoming inaccessible. If the new storage array has a different security key installed and already has a security-enabled volume, changing the security key will prevent access to the existing security-enabled volume.

Security capable drives can be used in volumes that are not security-enabled without enabling the drive security feature. In that case, volume groups containing such drives can be relocated without regard for the security key.

Data Assurance

The SafeStore Data Assurance (DA) premium feature checks for and corrects errors that might occur as data is communicated between a host and a storage array. DA is implemented using the SCSI direct-access block-device protection information model.

Only certain configurations of hardware that include DA-capable drives support the DA premium feature. When you install the DA premium feature on a storage array, SANtricity ES Storage Manager provides options to use DA with certain operations. For example, you can create a volume group that includes DA-capable drives, and then create a volume within that volume group that is DA-enabled.

When you move a volume group that includes a DA-enabled volume, the destination storage array must have the DA premium feature installed to continue using the feature. If the feature is not installed on the destination storage array, data will still be accessible on the volume without the error checking provided by DA.

Solid State Disk (SSD) Drives

The option to use Solid State Disk (SSD) drives in place of conventional drives is available as a premium feature with some hardware. The FC4600 drive tray and the DE1600 drive tray can have SSD drives. If you relocate a volume group that includes SSD drives, the destination hardware must support those drives.

Requirements for Moving Configured Hardware

Before you move any configured hardware, you must make sure that all of the requirements to move the drives or the drive trays have been met. To make sure that all the requirements are met, complete all of the tasks in this section.



ATTENTION Possible data loss or corruption – Export a volume group whenever possible. This action makes sure that any volume groups or volumes that you move to different destination storage arrays are correctly recognized and managed by the new storage array.

Checking the Version of the Enterprise Management Window

Make sure that the version of SANtricity ES Storage Manager that you use to open the Array Management Windows for the source storage array and the destination storage array is supported.

1. Open the Enterprise Management Window.
2. Select **Help >> About**.
The **About SANtricity ES Storage Manager** window appears.
3. Write down the version number of the Enterprise Management Window.
4. Click **OK**.
5. Go to [“Checking the Version of the Array Management Window.”](#)

Checking the Version of the Array Management Window

Make sure that the version of SANtricity ES Storage Manager that you use to manage both the source storage array and the destination storage arrays is supported.

1. Open the Enterprise Management Window, if necessary.
2. Select the source storage array in the **Device Tree**, and start its Array Management Window.
If the Array Management Window for the selected storage array is already open on the storage management station, a second Array Management Window does not open.
3. Select **Help >> About**.
The **About SANtricity ES Storage Manager** window appears.
4. Make sure that the version number of the Array Management Window is not restricted. For restrictions, see "[Software Restrictions and Firmware Restrictions](#)."
5. Click **OK**.
6. Repeat step 2 through step 5 for the destination storage array.
7. Go to "[Creating Storage Array All Support Data Collections](#)."

Creating Storage Array All Support Data Collections

Create and save a storage array all support data collection for each source storage array and each destination storage array that is affected by the relocation procedure.

A storage array all support data collection provides a view of the current configuration and contains a description of all the components and properties of a storage array.

All of the files gathered are compressed into a single archive in a zipped format.

1. To create a storage array all support data collection for the source storage array, perform these actions:
 - a. Open the Enterprise Management Window, if necessary.
 - b. Select the source storage array in the **Device Tree**, and start its Array Management Window.
If the Array Management Window for the selected storage array is already open on the storage management station, a second Array Management Window does not open.
 - c. From the **Logical/Physical** tab, select the storage array root node.
 - d. Select **Advanced >> Troubleshooting >> Collect All Support Data**.
The **Collect All Support Data** dialog appears.
 - e. In the **Specify filename** text box, either enter a name for the file to be saved, or browse to a previously saved file to overwrite an existing file.
 - f. Click **Start**.
A dialog shows the progress of the processing.
 - g. After all of the support files have been gathered and archived, click **OK**.
2. Repeat step 1 for the destination storage array.
3. Go to "[Checking the Version of the Controller Firmware](#)."

Checking the Version of the Controller Firmware

Make sure that the controller firmware version for all of the source storage arrays and the destination storage arrays affected by the relocation is later than the required level. The version number is listed in the Summary section of the storage array all support data collection. For more information about data collections, see [“Creating Storage Array All Support Data Collections.”](#)

Based on the version of the controller firmware, perform one of these actions:

- **The version of the controller firmware is correct for the storage management software** – Go to [“Checking the Host Types.”](#)
- **The version of the controller firmware is not correct for the storage management software version** – Upgrade the controller firmware to an appropriate version, and go to [“Checking the Host Types.”](#) For information about restrictions, see [“Software Restrictions and Firmware Restrictions.”](#)

Checking the Host Types

Make sure that the host types defined for the destination storage array are the same as the host types defined for the source storage array. The operating system is listed in the Mappings section of the storage array all support data collection.

 **ATTENTION Possible loss of data when you move volume groups created with SANtricity ES Storage Manager Version 10.10** – You cannot move a volume group from a storage array that is managed with SANtricity ES Storage Manager Version 10.10 to a storage array that is managed by an earlier version of SANtricity ES Storage Manager. The configuration about the drives might be overwritten, and data loss can occur.

1. Based on the type of relocation you want to do, perform one of these actions:
 - **The operating system is the same on the hosts that are connected to the source storage array and the destination storage array** – Go to step 2.
 - **The operating system is different for the hosts that are connected to the source storage array and the destination storage array** – You can move drives to another storage array to gain additional capacity (data is not preserved). Go to [“Moving Drives to a New Storage Array for Additional Capacity – Data Is Preserved.”](#)
2. Use one these options to move the drives and the drive trays:
 - **Move the drives to another storage array to be used for additional capacity (data is not preserved)** – Go to [“Moving Drives to a New Storage Array for Additional Capacity – Data Is Preserved.”](#)
 - **Export and import volume groups (data is preserved)** – Go to [“Exporting and Importing a Volume Group.”](#)
 - **Move configured volumes to another storage array (data is preserved)** – Go to [“Moving a Volume Group to a Different Storage Array – Data Is Preserved.”](#)
 - **Move a drive tray from one storage array to another (data is preserved)** – Go to [“Moving a Drive Tray to a Different Storage Array – Data Is Preserved.”](#)

Moving Drives to a New Storage Array for Additional Capacity – Data Is Preserved



IMPORTANT Data is *not* preserved when you move drives to a new storage array to obtain additional capacity.

This procedure removes all data and configuration information from the drives so that you have unconfigured drives that can be reused.

Relocation Process Overview



ATTENTION Possible loss of data – When you delete a volume group and its volumes, all data is removed, which includes snapshot volumes and associated snapshot repository volumes. The associated volumes return to an Unassigned status. *You cannot cancel this operation after it starts.* Use this option only if you do not want to keep the data or volume information on the drives.

You can move drives from one storage array to a destination storage array to add unconfigured capacity to the destination storage array. You must remove all volume group information and volume information from the drives while they reside on the source storage array. This action prepares the drives so that they come online automatically in the destination storage array and are ready to configure for use.

To move drives from one storage array to another to add unconfigured capacity, perform the following procedures:

1. Check the status of the source storage array and the destination storage array.
2. Delete the volume groups from the source storage array.
3. Remove the drives from the source storage array.
4. Install the drives in the destination storage array.
5. Initialize the drives in the destination storage array.
6. Delete a volume group in the destination storage array.

When the procedure is completed, the drives are ready to configure and use.

Relocation Procedure

Complete the procedures in these sections to move drives from a source storage array to a new destination storage array for additional capacity.

Checking the Status of the Source Storage Array and the Destination Storage Array

1. Make sure that the requirements to move the drives have been met.

For information, see "[Understanding Concepts, Restrictions, and Requirements of Volume Group Relocation.](#)"



IMPORTANT Depending on the size of the storage array, a full backup could take several hours or several days.

2. Make sure that the data that must be preserved on the volume group in the source storage array has been backed up and transferred to another volume group.

3. Make sure that empty drive slots are available in the destination storage array.
4. Open the Enterprise Management Window.
5. Select the storage array in the Device table, and start its Array Management Window.
6. In the Physical pane, make sure that the same number of empty drive slots exist as the number of drives that you want to move.



IMPORTANT Before you can delete the volumes and the volume group, the volume group and its associated standard volumes and snapshot repository volumes must have a status of Optimal in the Logical pane of the Array Management Window.

7. Check the status of the volume group and its related volumes on the source storage array.
To view a message that describes the status, move your mouse pointer over the volume group or volume in the Logical pane.
8. Based on the status of the volume group and volumes, perform one of these actions:
 - **The status is Optimal** – Go to step 11.
 - **The status is Optimal - Operation in Progress** – Go to step 9.
 - **The status is Failed or Degraded** – If a volume or snapshot repository volume appears with a Failed status or a Degraded status, go to step 10.
9. If the Optimal - Operation in Progress indicator appears, perform these actions:
 - a. Wait for the volume modification operation to complete, which includes these processes:
 - Defragmentation
 - Copyback
 - Initialization
 - Dynamic segment sizing
 - Dynamic reconstruction
 - Dynamic RAID-level migration
 - Dynamic capacity expansion
 - Dynamic volume expansion
 - b. Make sure that the status of the volume group and the volume is Optimal.
 - c. Go to step 11.
10. Perform these actions:
 - a. Use the Recovery Guru to diagnose the problem and to present the appropriate recovery procedure.
 - b. Perform the recovery procedure.
 - c. Make sure that the volume has a status of Optimal.
 - d. Go to step 11.



IMPORTANT You can assign global hot spares on the source storage array, but they cannot be in use for the specified volume group. The status of a global hot spare that is assigned but is not in use is Standby/Optimal. If you move the mouse over a global hot spare in the Physical pane of the Array Management Window, a message appears that describes the status.

11. Make sure that global hot spares are not in use for drives in the volume group that you move from the *source* storage array.

- a. From the Logical pane, select the appropriate volume group.
- b. In the Physical pane, make sure that blue association dots do not appear underneath any global hot spare.
- c. Go to “[Deleting the Volume Groups from the Source Storage Array](#).”

Deleting the Volume Groups from the Source Storage Array



ATTENTION Possible loss of data – If you delete a volume group and its volumes, all data is removed, which includes snapshot volumes and associated snapshot repository volumes. The associated drives return to an Unassigned status. *You cannot cancel this operation after it starts.* Use this option only if you do not want to retain the data or the volume information about the drives.



IMPORTANT To permanently remove any information about the deleted volumes, you must restart the host system.

This procedure prepares the drives to come online automatically in the destination storage array to be ready to configure and use.



IMPORTANT If mirror repository volumes exist in the volume group, and you delete the volume group, the action does not remove the mirror repository volumes. You must deactivate the Remote Volume Mirroring premium feature first. For information, refer to the topics under *SANtricity ES Storage Manager Remote Volume Mirroring*, The corresponding PDF document on the SANtricity ES Storage Manager Installation DVD, or the online help topics in the Array Management Window.

1. Stop I/O activity to the volume group on the source storage array, and unmount all file systems.
2. Physically locate the drives assigned to the volume group that you want to delete by turning the LED on to each drive.
 - a. From the Logical pane of the Array Management Window for the source storage array, select the appropriate volume group.
A blue association dot appears under each drive in the volume group in the Array Management Window.
 - b. Select **Volume Group >> Locate**.
The **Locate Volume Group** dialog appears, and the drive LEDs blink above or below the drives in the storage array.
3. Physically mark the drives in the storage array.
4. To stop the blinking LEDs, in the **Locate Volume Group** dialog, click **OK**.
5. From the Logical pane, select the volume group that you want to delete.
6. Select **Volume Group >> Delete**.
7. In the **Delete Volume Group** dialog, select one or more volume groups.
8. Click **Delete**.
9. In the **Confirm Delete Volume Group** dialog, type *yes* to confirm the removal of the selected volume groups and any associated volumes.
10. Click **OK**.
 - In the Physical pane, the status of all of the associated assigned drives in the selected volume group changes to an Unassigned status.

- In the Logical pane, the volume group and all of its associated volumes are deleted and their icons are removed.
 - If there is a current Unconfigured Capacity node, the raw capacity of the drives is added to it.
 - If an Unconfigured Capacity node did not exist before the deletion operation of the volume group, a new Unconfigured Capacity node is added to the Logical pane. The raw capacity of the drives is added to it.

11. Go to [“Removing the Drives from the Source Storage Array.”](#)

Removing the Drives from the Source Storage Array

 **ATTENTION Possible hardware damage** – To prevent electrostatic discharge damage to the tray, use proper antistatic protection when handling tray components.

1. Create a storage array all support data collection.

For information about creating a storage array all support data collection, see [“Creating Storage Array All Support Data Collections.”](#)

- a. Save the storage array all support data collection.
- b. Open and view the storage array all support data collection files.

2. Put on antistatic protection.

 **ATTENTION Possible damage to drives** – If you bump drives against another surface, the drive mechanism or connectors can be damaged. To avoid damage when you remove or install a drive, always place your hand under the drive canister to support its weight. Do not touch the electronics on the drive.

3. Open the lever on the first drive canister, and pull the drive out of the drive tray approximately 5 cm (2 in.) to disengage the drive.

4. Wait at least two minutes for the drive to spin down.

The status of the drive changes from Unassigned to an empty drive slot in the Physical pane of the Array Management Window.

5. Repeat step 3 through step 4 for each drive that must be removed.

6. After the drives have spun down, remove them from the drive tray. Put the drives on an antistatic, cushioned surface away from magnetic fields.

Make sure that you put your hand under each drive to support its weight when you remove it from the drive tray.

7. To maintain correct airflow, insert blank drive canisters into any empty drive slots in the drive trays in the source storage array.

 **IMPORTANT** To maintain correct airflow in the drive tray, you must fill all of the drive slots. If you do not have drives for the drive slots, insert blank drive canisters.

8. Go to [“Installing the Drives in the Destination Storage Array.”](#)

Installing the Drives in the Destination Storage Array

 **IMPORTANT** If all of the volume group information and the volume information was not removed from the drives on the source storage array, unexpected volume groups can appear in the Logical pane of the Array Management Window. This condition occurs after the drives are installed in the destination storage array. Remove the volume group information and the volume information to return the drives to an Unassigned status.



IMPORTANT Wait at least two minutes for the controller to write information before you reinstall a drive. If you install more than one drive and the controller is not given enough time to recognize each drive, the storage array can enter into an Unstable status. If time is not available, you must restart both controllers, which forces the controller to write the information to the DACstore.

1. Install the drives, one at a time, into the destination storage array.
 - a. Install the drive in one complete motion by inserting it all the way into the slot in the drive tray.
 - b. Lower (close) the lever to lock the drive securely in place.
 - c. Before you install the next drive, wait until the status of the empty drive slot changes to Unassigned in the Physical pane of the Array Management Window.
2. Based on the status of the drive, perform one of these actions:
 - **The status of the drive changes to Unassigned** – Repeat step 1 to install all of drives, and go to step 4.
 - **The status of the drive does not change to Unassigned** – Go to step 3.
3. If the status of the drive does not appear as Unassigned in the Physical pane of the Array Management Window, perform these steps:
 - a. Open the lever, and pull the drive out of the drive tray approximately 5 cm (2 in.).
 - b. Wait at least two minutes for the drive to spin down.
 - c. Reinstall the drive in one complete motion by inserting it all the way into the slot.
 - d. Lower (close) the lever to lock the drive securely in place.



IMPORTANT If the drive does not appear in the Array Management Window, the drive might be defective. Remove the drive, and replace it with another drive.

- e. Before you install the next drive, wait at least two minutes until the drive appears in the Array Management Window.
- f. Repeat step a through step e until the status of all of the drives appears as Unassigned. Go to step 4.
4. Based on what appears in the Logical pane of the Array Management Window, perform one of these actions:
 - **The capacity of the drives is added successfully to the Unconfigured Capacity node** – If the capacity of the drives was added to the Unconfigured Capacity node in the Logical pane of the Array Management Window, the drives have been moved successfully and are ready to be configured. To complete the relocation process, configure the drives. For information about how to create volume groups and volumes, refer to the online help topics in the Array Management Window.
 - **Unexpected volume groups appear** – If unexpected volume groups appear in the Logical pane of the Array Management Window, the volume group information and the volume information might not have been removed from the drives completely. You must remove the volume group information and the volume information completely to return the drives to an Unassigned status and for the capacity of the drives to be added to the Unconfigured Capacity node. Go to step 5.
5. Based on the status of the unexpected volume group, perform one of these actions:
 - **The volume group is offline** – Go to [“Initializing the Drives in the Destination Storage Array.”](#)
 - **The volume group is online** – Go to [“Deleting a Volume Group in the Destination Storage Array.”](#)

Initializing the Drives in the Destination Storage Array

When volumes that were previously part of a multi-drive volume group are relocated from one storage array to another, the volume groups can appear Offline in the Logical pane of the Array Management Window. This situation occurs because the volume group information and the volume information about the drives are incomplete.

To resolve the problem, you must initialize the drives. This action erases the volume group information and the volume information and returns the selected drives to an Unassigned state. When you put the drives into an Unassigned state, you add new capacity or additional unconfigured capacity to the storage array.

When the drives are initialized, the status of the drives changes to Unassigned. If a current Unconfigured Capacity node exists, the raw capacity of the drives is added to it. Otherwise, a new Unconfigured Capacity node is added to the Logical pane with the raw capacity of the drives added to it. When you initialize the drives, all of the data is removed from the drives.



IMPORTANT If the status of the unexpected volume groups is Optimal, you must delete the volume group. Go to [“Deleting a Volume Group in the Destination Storage Array.”](#)

After you have completed the procedure, the drives come online and are ready to be configured and used.

1. Make sure that the status of the volume group and its associated volumes is Offline.

These entities show an Offline status:

- **The volume group and the volume** – If you move the mouse pointer over the volume group or the volume in the Logical pane of the Array Management Window, a message shows the status as Offline.
- **The drive needs attention** – If you move the mouse pointer over the drives in the Physical pane of the Array Management Window, a message shows the status as Offline.



ATTENTION Possible loss of data – If you initialize a drive, all of the volume information is deleted, and the selected drives return to an Unassigned status. *You cannot cancel this operation after it starts.*

2. From the Physical pane, select the drives that you want to initialize.

To select multiple drives, hold down the **Ctrl** key, and select the drives.

3. Select **Advanced >> Recovery >> Initialize >> Drive**.

4. To start the drive initialization process, type *yes*, and click **OK**.

When the storage arrays initialize, each volume icon shows as Operation in Progress in the Logical pane. After the storage array initializes, the Array Management Window shows these conditions:

- In the Physical pane, the status of the drives changes to Unassigned.
- In the Logical pane, the volume group and all of its associated volumes are deleted, and their icons are removed.
 - If a current Unconfigured Capacity node exists, the raw capacity of the drives is added to it.
 - If an Unconfigured Capacity node did not exist before the drive initialization operation, a new Unconfigured Capacity node is added to the Logical pane. The raw capacity of the drives is added to it.

5. To complete the relocation process, configure the drives.

For information about how to create volume groups and volumes, refer to the online help topics in the Array Management Window.

Deleting a Volume Group in the Destination Storage Array



IMPORTANT If the status of the unexpected volume groups is *Offline*, you must initialize the drives. Go to [“Initializing the Drives in the Destination Storage Array.”](#)



IMPORTANT You must restart the host system to permanently remove any information about the deleted volumes.

If unexpected volume groups appear with a status of *Optimal* in the Logical pane after you have initialized the drives in the destination storage array, you must delete all of the volume groups and any associated volumes. This action removes the volume group information and the volume information.

When you delete the volume groups, the status of the drives that made up the capacity of the volume group changes to an *Unassigned* status. If a current *Unconfigured Capacity* node exists, the raw capacity of the drives is added to it. Otherwise, a new *Unconfigured Capacity* node is added to the Logical pane that contains the raw capacity of the drives. All of the data is removed from the drives.

1. From the Logical pane, select the volume group that you want to delete.
 2. Select **Volume Group >> Delete**.
-



ATTENTION Possible loss of data – If you delete a volume group and its volumes, this action removes all of the data, which includes any snapshot volumes or snapshot repository volumes. The associated drives return to an *Unassigned* status. *You cannot cancel this operation after it starts.*

3. In the **Delete Volume Group** dialog, select one or more volume groups.
4. Click **Delete**.
5. In the **Confirm Delete Volume Group** dialog, type *yes* to confirm the removal of the volume groups.
6. Click **OK**.
 - In the Physical pane, the status of all of the associated assigned drives in the selected volume group changes to an *Unassigned* status.
 - In the Logical pane, the volume group and all of its associated volumes are deleted, and their icons are removed.
 - If a current *Unconfigured Capacity* node exists, the raw capacity of the drives is added to it.
 - If an *Unconfigured Capacity* node did not exist before the volume group deletion operation, a new *Unconfigured Capacity* node is added to the Logical pane. The raw capacity of the drives is added to it.
7. To complete the relocation process, configure the drives.

For information about how to create volume groups or volumes, refer to the online help topics in the Array Management Window.

Exporting and Importing a Volume Group

For specific information about the export process and the import process, refer to the online help topics in the Array Management Window.

Volume group relocation lets you export a volume group so that you can import the volume group to a different storage array. You can also export a volume group so that you can store the data offline.



ATTENTION Possible loss of data access – You must export a volume group before you move the volume group or import the volume group.

Exporting a Volume Group

The export volume group operation prepares the drives in the volume group for removal. You can remove the drives for offline storage, or you can import the volume group to a different storage array. After you complete the export volume group operation, all of the drives are offline. Any associated volumes or Free Capacity nodes no longer appear in the storage management software.

Non-Exportable Components

You must remove any non-exportable components before you can complete the export volume group procedure. You must remove these components:

- Persistent reservations
- Host-to-volume mappings
- Volume copy pairs
- Snapshot volumes and snapshot repository volumes
- Remote mirror pairs
- Mirror repositories

Showing Volume Group Export Dependencies

The `exportDependencies` command shows a list of dependencies for the drives in a volume group that you want move from one storage array to a destination storage array.

For information about how to show volume group export dependencies, refer to the online help topics in the Array Management Window.

Starting Volume Group Export

The `export` command moves a volume group into an Exported state so that you can remove the drives that comprise the volume group and reinstall the drives in a destination storage array.



NOTE Within the volume group, you cannot move volumes that are associated with the premium features from one storage array to another storage array.

For information about how to start volume group export, refer to the online help topics in the Array Management Window.

Importing a Volume Group

The import volume group operation adds the exported volume group to the destination storage array. After you complete the import volume group operation, all of the drives have Optimal status. Any associated volumes or Free Capacity nodes now appear in the storage management software that is installed on the destination storage array.

Non-Importable Components

Some components cannot be imported during the import volume group procedure. These components are removed during the procedure:

- Persistent reservations
- Host-to-volume mappings
- Volume copy pairs
- Snapshot volumes and snapshot repository volumes
- Remote mirror pairs
- Mirror repositories

Showing the Volume Group Import Dependencies

The `importDependencies` command shows a list of dependencies for the drives in a volume group that you want to move from one storage array to a destination storage array.

For information about how to show the volume group import dependencies, refer to the online help topics in the Array Management Window.

Starting Volume Group Import

The `import` command moves a volume group into a Optimal status to create a newly introduced volume group that is available to the destination storage array. The volume group must be in an Exported state or a Contingent state before running this command. Upon successfully running the command, the volume group is operational.





NOTE Within the volume group, you cannot move volumes that are associated with the premium features from one storage array to a destination storage array.

For information about how to start the volume group import, refer to the online help topics in the Array Management Window.

Moving a Volume Group to a Different Storage Array – Data Is Preserved

Relocation Process Overview

 **ATTENTION Possible data loss or corruption** – Perform the hot volume group relocation whenever possible. This action makes sure that any volume groups or volumes that you move to different destination storage arrays are correctly recognized and managed by the new storage arrays.

 **IMPORTANT** Use the procedures listed below only when you move a volume group from one storage array to another (data is preserved).

To move a volume group from one storage array to another, perform these procedures. Each procedure has a separate topic with detailed steps.

1. Locate the drives in the volume group.
2. Check the status of the source storage array and the destination storage array.
3. Remove the copy pairs.
4. Remove the mirror relationships.
5. Delete a snapshot volume.
6. Check the NVSRAM bit for the destination storage array.
7. Change the NVSRAM bit for the destination storage array (if needed).
8. Remove the drives from the source storage array.
9. Delete a missing volume.
10. Install the drives into the destination storage array.
11. Define new storage partitions.
12. Complete the volume group relocation.

Locating the Drives in a Volume Group

The drives that comprise a volume group usually are located in multiple drive trays in a storage array. If you move a volume group from one storage array to another storage array, you are required to identify which drives to relocate to the destination storage array. You are also required to identify which volume groups will stay in the source storage array.

1. Based on whether snapshot volumes exist in the volume group, perform one of these actions:
 - **Snapshot volumes exist in the volume group** – Go to step 2.
 - **Snapshot volumes do not exist in the volume group** – Go to step 4.

 **IMPORTANT** If you have created a snapshot volume of a base volume, in some cases, the snapshot repository volume and base volume might reside in different volume groups. If you want to keep the data in the snapshot volume, you must locate and move all of the volume groups that contain snapshot repository volumes that are associated with the snapshot volume. If you do not move all of the associated volumes, the snapshot volume will become unusable in both storage arrays.

2. Locate the snapshot repository volume that is associated with the snapshot volume in the volume group that you want to move.
 - a. Open the Enterprise Management Window.
 - b. Select the source storage array in the **Device** table, and start its Array Management Window.

If the Array Management Window for the selected storage array is already open on the storage management station, a second Array Management Window does not open.
 - c. From the Logical pane, right-click a snapshot volume, and select **View Associated Components** from the pop-up menu.
3. In the **Volume - Associated Components** dialog, make sure that the snapshot repository volume is in the same volume group as the snapshot volume, and perform one of these actions:
 - **The snapshot repository volume is in a different volume group** – Repeat step 2 for the volume group that contains the snapshot repository volume. When you have completed these tasks for all of the volume groups, go to step 4.
 - **The snapshot repository volume is in the same volume group** – Go to step 4.
4. Physically locate the drives in the selected volume group by activating the LED on each drive.
 - a. In the Logical pane, select the volume group.

A blue association dot appears under each drive in the volume group in the Array Management Window.
 - b. Select **Volume Group >> Locate**.

The **Locate Volume Group** dialog appears, and the Drive LEDs blink above or below the drives in the storage array.
5. Physically mark the drives in the storage array to identify whether the drive is part of a volume group that stays in the source storage array or whether the drive is part of a volume group that you want to move to the destination storage array.
6. To stop the blinking LEDs, in the **Locate Volume Group** dialog, click **OK**.
7. Repeat step 1 through step 6 for all of the volume groups that you want to remove from the storage array.
8. Go to “[Checking the Status of the Source Storage Array and the Destination Storage Array.](#)”

Checking the Status of the Source Storage Array and the Destination Storage Array

1. Make sure that the requirements to move the drives have been met.

For information, see “[Understanding Concepts, Restrictions, and Requirements of Volume Group Relocation.](#)”



IMPORTANT Depending on the size of the storage array, a full backup could take several hours or several days.

2. Make sure that the data that must be preserved on the volume group in the source storage array has been backed up.
3. Determine whether the volume group that you move from the source storage array contains volumes that participate in a volume copy.
 - a. Open the Enterprise Management Window.
 - b. Select the source storage array in the **Device** table, and start its Array Management Window.

If the Array Management Window for the selected storage array is already open on the storage management station, a second Array Management Window does not open.

- c. In the Logical pane, look for any volumes that are a source volume or a target volume that you want to participate in a volume copy.
4. Based on whether volumes that participate in a volume copy exist in the volume group, perform one of these actions:
 - **Volumes that participate in a volume copy exist in the volume group** – Go to “[Removing the Copy Pairs](#).” When you have removed the volume copies from the source storage array, return to step 5 in this procedure.
 - **Volumes that participate in a volume copy do not exist in the volume group** – Go to step 5.
5. Determine whether the volume group that you move contains mirror relationships.
 - a. Open the Enterprise Management Window.
 - b. Select the source storage array in the **Device** table, and start its Array Management Window.

If the Array Management Window for the selected storage array is already open on the storage management station, a second Array Management Window does not open.
 - c. In the Logical pane, look for any volumes that are identified with a label as a primary volume or a secondary volume.
6. Based on whether mirror relationships exist in the volume group, perform one of these actions:
 - **Mirror relationships exist in the volume group** – Go to “[Removing the Mirror Relationships](#).” If you remove the mirror relationships from the storage array, you prevent orphan mirrors in the secondary storage array. When you have removed the mirror relationships, return to step 7 in this procedure.
 - **Mirror relationships do not exist in the volume group** – Go to step 7.
7. Determine whether the volume group that you will move contains snapshot volumes.
 - a. Open the Enterprise Management Window.
 - b. Select the source storage array in the **Device** table, and start its Array Management Window.

If the Array Management Window for the selected storage array is already open on the storage management station, a second Array Management Window does not open.
 - c. In the Logical pane, look for any volumes that are identified with a label as a snapshot volume.
8. Based on whether snapshot volumes exist in the volume group, perform one of these actions.
 - **Snapshot volumes exist in the volume group** – Go to step 9.
 - **Snapshot volumes do not exist in the volume group** – Go to step 10.



IMPORTANT If you have created a snapshot volume of a base volume, and you do not want to keep the data in the snapshot volume, delete the snapshot volume before you move the volume group.

9. Determine whether the snapshot volumes contain data that you want to keep, and perform one of these actions:
 - **Delete the snapshot volumes** – Go to “[Deleting a Snapshot Volume](#).” When you have deleted the snapshot volumes, return to step 10 in this procedure.
 - **Retain the snapshot volumes** – Go to step 10.
10. Make sure that the number of drives in the volume group that you want to move is correct.
 - a. Open the Enterprise Management Window.
 - b. Select the source storage array in the **Device** table, and start its Array Management Window.

If the Array Management Window for the selected storage array is already open on the storage management station, a second Array Management Window does not open.
 - c. In the Logical pane, select the volume group.

- A blue association dot appears under each drive in the volume group in the Array Management Window.
- d. Repeat step **a** through step **c** for all of the volume groups that you want to move to the destination storage array.
11. Make sure that empty drive slots are available in the destination storage array.
 - a. Open the Enterprise Management Window.
 - b. Select the destination storage array in the **Device** table, and start its Array Management Window.

If the Array Management Window for the selected storage array is already open on the storage management station, a second Array Management Window does not open.
 - c. In the Physical pane, make sure that the same number of empty drive slots are available as the number of drives that you want to move.
 12. Check the status of the volume group and its associated volumes in the *source* storage array.

To view a message that describes the status, move your mouse pointer over the volume group or the volume in the Logical pane.
 13. Based on the status indicator, perform one of these actions:
 - **The status is Optimal or Contingent** – Go to step **16**.
 - **The status is Optimal - Operation in Progress** – Go to step **14**.
 - **The status is Failed or Degraded** – Go to step **15**.
 14. If the Optimal - Operation in Progress indicator appears, perform these actions:
 - a. Wait for the volume modification operation to complete, which includes these processes:
 - Defragmentation
 - Copyback
 - Initialization
 - Dynamic segment sizing
 - Dynamic reconstruction rate
 - Dynamic RAID-level migration
 - Dynamic capacity expansion
 - Dynamic volume expansion
 - b. Make sure that the status of the volume group and the status of the volume are Optimal or Contingent.
 - c. Go to step **16**.
 15. If a volume or a repository volume shows a Failed status or Degraded status, perform these actions:
 - a. Use the Recovery Guru to diagnose the problem and present the appropriate recovery procedure.
 - b. Make sure that the volume has a status of Optimal or Contingent.
 - c. Go to step **16**.
 16. Make sure that global hot spares are not in use for drives in the volume group that you move from the *source* storage array.
 - a. Open the Enterprise Management Window.
 - b. Select the source storage array in the **Device** table, and start its Array Management Window.

If the Array Management Window for the selected storage array is already open on the storage management station, a second Array Management Window does not open.

- c. In the Logical pane, select the appropriate volume group.
 - d. In the Physical pane, make sure that blue association dots *do not* appear underneath any global hot spares.
17. Based on the status of any global hot spares, perform one of these actions:
- **Global hot spares are in use for a drive in the volume group** – Use the Recovery Guru to diagnose the problem and to show the appropriate recovery procedure. Perform the recovery procedure, and make sure that global hot spares are not in use. Go to step 18.
 - **Global hot spares are *not* in use for a drive in the volume group** – Go to step 18.
18. Repeat step 1 through step 17 for all of the volume groups that you want to move.
19. Go to “[Checking the NVSRAM Bit for the Destination Storage Array.](#)”

Removing the Copy Pairs

Before you move volumes that participate in a volume copy to a different destination storage array, make sure that any copy pairs are removed. This verification prevents absent volumes on the destination storage array.



IMPORTANT This option does not delete the source volume or the target volume. Data on the volumes is not affected. As a result of this operation, you can select the target volume as a source volume or a target volume for a new volume copy.

1. Open the Enterprise Management Window.
2. Select the source storage array in the **Device** table, and start its Array Management Window.
If the Array Management Window for the selected storage array is already open on the storage management station, a second Array Management Window does not open.
3. Select **Volume >> Copy >> Copy Manager**.
The **Copy Manager** dialog appears.
4. Select one or more copy pairs in the table.
To select multiple copy pairs, either press **Ctrl** and the left mouse button, or press **Shift** and the left mouse button.
5. Select **Copy >> Remove Copy Pairs**.
The **Remove Copy Pairs** dialog appears.
6. Click **Yes**.
The volume copy is removed.
7. Close Copy Manager.
8. To complete the checking of the status of the source storage array, return to step 5 in “[Checking the Status of the Source Storage Array and the Destination Storage Array.](#)”

Removing the Mirror Relationships

Before you relocate volumes that participate in a mirror relationship, you must remove the mirror relationship between the primary volumes and the secondary volumes. This action prevents orphan mirrors on the remote storage array.

 **IMPORTANT** This option does not delete the primary volume, the secondary volume, or the mirror repository volumes that support mirroring for the storage arrays. Data on the volumes is not affected. As a result of this operation, the primary volume and the secondary volume become standard, host accessible, non-mirrored volumes.

1. Open the Enterprise Management Window.
2. Select the source storage array in the **Device** table, and start its Array Management Window.
If the Array Management Window for the selected storage array is already open on the storage management station, a second Array Management Window does not open.
3. In the Logical pane, select the primary volume or the secondary volume that is participating in the mirror relationship.
4. Select **Volume >> Remote Volume Mirroring >> Remove Mirror Relationship**.
The **Remove Mirror Relationship** dialog appears.
5. From the **Select one or more mirrored pairs** list, select the mirrored volume pairs for which you want to remove the mirror relationship.
To select multiple mirrored pairs, either press **Ctrl** and the left mouse button, or press **Shift** and the left mouse button. To select all of the mirrored pairs, click the **Select All** button.
6. Click **OK**.
The **Remove Mirror Relationship - Confirmation** dialog appears.
7. Click **Yes**.
The **Remove Mirror Relationship - Progress** dialog appears. When the mirror relationship is removed, the volumes in the mirrored pairs that you selected are no longer part of a mirror relationship. All data on the volumes stays intact and available. Secondary volumes become accessible by hosts that are mapped to them.
8. To complete the checking of the status of the source storage array, return to step 6 in "[Checking the Status of the Source Storage Array and the Destination Storage Array.](#)"

Deleting a Snapshot Volume

 **ATTENTION Possible loss of data** – If you delete a snapshot volume, all data is removed on the volume, and the associated snapshot repository volume is deleted. This action occurs even if the snapshot repository volume is not located in the same volume group. *You cannot cancel this operation after it starts.*

 **IMPORTANT** Depending on the size of the storage array, a full backup could take several hours or several days.

 **IMPORTANT** A volume group and its associated standard volumes and snapshot repository volumes must have a status of Optimal in the Logical pane of the Array Management Window before you can delete them.

 **IMPORTANT** A snapshot volume must have a status of Optimal or Contingent before you can delete it.

1. Back up any data on the volume.
2. Stop I/O activity to the destination storage array, and unmount all file systems.
3. Open the Enterprise Management Window.
4. Select the source storage array in the **Device** table, and start its Array Management Window.

If the Array Management Window for the selected storage array is already open on the storage management station, a second Array Management Window does not open.



IMPORTANT You cannot delete a volume that is part of a volume group that contains a drive that is performing a copyback operation.

5. Make sure that the status of the snapshot volume is Optimal, Disabled, or Failed. If the volume has a different status, correct any problems with the volume before you continue with this procedure.
6. In the Logical pane, select the snapshot volume that you want to delete.
7. Select **Volume >> Delete**.
To select multiple snapshot volumes, either press **Ctrl** and the left mouse button, or press **Shift** and the left mouse button.
The **Delete Volumes** dialog appears.
8. Click **Delete**.
A confirmation dialog appears.
9. Type *yes*, and click **OK**.
The **Delete Volume - Progress** dialog appears while the snapshot volume and its associated snapshot repository volume are deleted. The free capacity in the volume group increases or additional unconfigured capacity becomes available.
For information about snapshot volumes, refer to the online help topics in the Array Management Window.
10. If additional snapshot volumes are to be deleted, repeat step 5 through step 9.
11. If you see a system error message that relates to the deleted volume, either reconfigure your host system, or restart your host system. These actions permanently remove any system information about the volume.
12. To complete the checking of the status of the source storage array, return to step 10 in [“Checking the Status of the Source Storage Array and the Destination Storage Array.”](#)

Checking the NVSRAM Bit for the Destination Storage Array

You must check the setting of the Disable Drive Migration feature bit (bit 1 in offset x35) in the NVSRAM on the destination storage array before you can move the drives. Use the **Script Editor** dialog in the Enterprise Management Window to check the setting.

Before you install volume groups that contain data that must be preserved, you must clear the Disable Drive Migration feature bit (set it to 0) on the destination storage array.

1. Open the Enterprise Management Window, if necessary.
2. Select the destination storage array in the Device Tree view or the Device table.
3. Select **Tools >> Execute Script**.
4. In the upper pane of the **Script Editor** dialog, type these statements. Press **Enter** after each statement.

```
show controller [a] NVSRAMByte [0x35];
```

```
show controller [b] NVSRAMByte [0x35];
```

5. To run the script, from the menu bar on the **Script Editor** dialog, select **Tools >> Execute Only**.

```
Controller "a" NVSRAM offset 0x35 = byte_value.
```

Controller "b" NVSRAM offset 0x35 = *byte_value*.

In these commands, *byte_value* = 0 enables drive migrations, or *byte_value* = 1 disables drive migrations.

The current hexadecimal value of the Disable Drive Migration feature bit appears in the lower pane of the **Script Editor** dialog.

6. Depending on the *byte_value* that is returned from each controller, perform one of these actions:
 - **The byte value returned from each controller is 0x00** – The Disable Drive Migration feature bit is cleared. Go to [“Changing the NVSRAM Bit for the Destination Storage Array.”](#)
 - **The byte value returned from each controller is any value other than 0x00** – You must determine the value of the Disable Drive Migration feature bit by using the Disable Drive Migration feature bit as bit 1 of this NVSRAM offset. If you do not know how to perform this operation, contact the next level of support for more information.

Changing the NVSRAM Bit for the Destination Storage Array

Before you install the drives from the source storage array into the destination storage array, you must clear the Disable Drive Migration feature bit (set it to 0) on the destination storage array. Use the **Script Editor** in the Enterprise Management Window to change the setting.



IMPORTANT After you clear the Disable Drive Migration feature bit (set it to 0), you must power off and power on the entire storage array of the controller tray or the controller-drive tray.

1. Stop I/O activity to the destination storage array, and unmount all file systems.
2. Is the **Script Editor** dialog Open?
 - **Yes** – Select **File >> New Script**. Go to step 6.
 - **No** – Go to step 3.
3. Open the Enterprise Management Window, if necessary.
4. Select the destination storage array in the Device Tree view or the Device table.
5. Select **Tools >> Execute Script**.
6. Type these statements in the upper window in the **Script Editor** dialog. Press **Enter** after each statement.

```
set controller [a] NVSRAMByte [0x35] = 0x00;
```

```
set controller [b] NVSRAMByte [0x35] = 0x00;
```

7. To run the script, from the menu bar on the **Script Editor** dialog, select **Tools >> Execute Only**.
8. Turn off the power to the controller tray or the controller-drive tray.
9. Wait 20 seconds, and turn on the power to the controller tray or the controller-drive tray.



NOTE After you turn on the power to the controller tray or the controller-drive tray, wait for the controllers to finish booting before proceeding to the next step.

10. To show the current hexadecimal values for the Disable Drive Migration feature bit, type these statements in the upper pane of the **Script Editor** dialog. Press **Enter** after each statement.

```
show controller [a] NVSRAMByte [0x35];
```

```
show controller [b] NVSRAMByte [0x35];
```

11. To run the script, from the menu bar on the **Script Editor** dialog, select **Tools >> Execute Only**.
12. Make sure that the current hexadecimal value of the Disable Drive Migration feature bit is set to 0.
The current hexadecimal value of the Disable Drive Migration feature bit appears in the lower pane of the **Script Editor** dialog.
13. To close the **Script Editor** dialog, select **File >> Exit**.
14. To close the confirmation dialog and to return to the Enterprise Management Window, click **No**.
15. Go to "[Removing and Relocating the Drives.](#)"

Removing the Drives from the Source Storage Array

If the volume group contains snapshot volumes, and the base volume and snapshot repository volumes are located in different volume groups, move the volumes in this order:

- First, remove the volume group with the base volume from the storage array.
- Second, remove the volume group with the snapshot repository volume.

You will need blank drive canisters to replace the drives that you remove.

 **ATTENTION Possible hardware damage** – To prevent electrostatic discharge damage to the tray, use proper antistatic protection when handling tray components.

1. Create a storage array all support data collection for the source storage array affected by the procedure.
 - a. Save the storage array all support data collection.
 - b. Open and view the storage array all support data collection files.

For information about creating a storage array all support data collection, see "[Creating Storage Array All Support Data Collections.](#)"

2. Put on antistatic protection.

 **ATTENTION Possible damage to drives** – If you bump drives against another surface, the drive mechanism or connectors can be damaged. To avoid damage when you remove or install a drive, always put your hand under the drive canister to support its weight. Do not touch the electronics on the drive.

3. Open the lever on the drive canister, and pull the drive out of the drive tray approximately 5 cm (2 in.).
4. Wait a minimum of two minutes for the drive to spin down.
The status of the drive changes from Unassigned to an empty drive slot in the Physical pane of the Array Management Window.
5. Repeat step 3 through step 4 for each drive canister that must be removed.
6. After the drive has spun down, remove it from the drive tray, and put it on an antistatic, cushioned surface away from magnetic fields.

Make sure that you put your hand under each drive to support its weight when you remove it from the drive tray.

 **IMPORTANT** To maintain correct airflow in the drive tray, you must fill all of the drive slots. If you do not have drives for the drive slots, insert blank drive canisters.

7. Insert blank drive canisters into the empty drive slots.



IMPORTANT After a volume group has been removed from the storage array, you might see absent volumes in the Logical pane of the Array Management Window. For information about absent volumes, refer to the online help topics in the Array Management Window.

8. Determine if any missing volumes are associated with the volume groups that you have removed.
 - a. Open the Enterprise Management Window.
 - b. Select the source storage array in the **Device** table, and start its Array Management Window.
If the Array Management Window for the selected storage array is already open on the storage management station, a second Array Management Window does not open.
 - c. In the Logical pane, see if any missing volumes are associated with the volume group that you want to move to the destination storage array.
 - d. Use the storage array all support data collection to identify the World Wide Identifier (WWID) for the volume.
9. Based on the status of any missing volumes, perform one of these actions:
 - **The missing volumes are associated with a volume group that you want to move to the destination storage array** – Go to “[Deleting a Missing Volume](#).” When you have deleted the missing volumes, return to step 8 in this procedure.
 - **The missing volumes are not associated with a volume group that you want to move to the destination storage array** – Go to step 10.
10. To move multiple volume groups, repeat step 3 through step 9.
11. Go to “[Installing the Drives into the Destination Storage Array](#).”

Deleting a Missing Volume

1. Open the Enterprise Management Window, if necessary.
2. Select the source storage array in the **Device** table, and start its Array Management Window.
If the Array Management Window for the selected storage array is already open on the storage management station, a second Array Management Window does not open.
3. In the Logical pane, locate the missing volume.
4. Use the storage array all support data collection to identify the World Wide Identifier (WWID) for the volume.



ATTENTION Data loss can occur if you delete an absent volume – If you delete a missing volume, you permanently remove the volume from the configuration. Any associated snapshot volumes, repository volumes, or volume-to-LUN mappings are also deleted. Do *not* delete missing volumes before you confirm that the volumes are no longer required.

5. Make sure that the missing volume is no longer needed. If you delete the missing volume, you permanently remove the volume from the configuration.
6. Delete any missing volumes that are associated with the volume group that you want to move to the destination storage array.
 - a. In the Logical pane, select a missing volume.
 - b. Select **Volume >> Delete**.
The **Delete Volumes** dialog appears.
 - c. Click **Delete**.
The **Confirm Delete Volume(s)** dialog appears.

- d. To permanently delete the missing volume from the configuration, type `yes`, and click **OK**.
If this volume is the last missing volume under the Missing Volumes Group node, the Missing Volumes Group node also is removed.
7. If additional missing volumes must be deleted, repeat step 3 through step 6.
8. If system error messages that relate to the deleted volume appear, either reconfigure your host system or restart your host system to permanently remove any system information about the volume.
9. To complete the procedure to remove drives from the source storage array, return to step 8 in “[Removing the Drives from the Source Storage Array.](#)”

Installing the Drives into the Destination Storage Array

When you complete this procedure, the drives come online automatically in the storage array.

 **IMPORTANT** Volume group numbering on the destination storage array might change after all of the drives in the volume group are installed. The controller automatically assigns volume group numbering for current volume groups and relocated volume groups.

If you have created a snapshot volume of a base volume, in some cases, the snapshot repository volume and the base volume might reside in different volume groups. If you want to keep the data in the snapshot volume, you must locate and move all of the volume groups that contain the snapshot repository volumes that associated with the snapshot volume. If you do not move all of the associated volumes, the snapshot volume will become unusable in both storage arrays.

-
1. Open the Enterprise Management Window.
 2. Select the destination storage array in the **Device** table, and start its Array Management Window.
If the Array Management Window for the selected storage array is already open on the storage management station, a second Array Management Window does not open.
 3. Make sure that empty drive slots are available in the Physical pane of the Array Management Window for the destination storage array.

 **ATTENTION Possible hardware damage** – To prevent electrostatic discharge damage to the tray, use proper antistatic protection when handling tray components.

-
4. Put on antistatic protection.
 5. Remove the blank drive canisters from the empty drive slots.

 **ATTENTION Possible damage to drives** – If you bump drives against another surface, the drive mechanism or connectors can be damaged. To avoid damage when you remove or install a drive, always put your hand under the drive canister to support its weight. Do not touch the electronics on the drive.

-
6. Install the drive canisters, one at a time, into the destination storage array.
 - a. Install each drive in one complete motion by inserting it all the way into the slot.
 - b. Lower (close) the lever to lock the drive securely into place.

 **IMPORTANT** Wait at least two minutes for the controller to write information before you reinstall a drive. If you install more than one drive and the controller is not given enough time to recognize each drive, the storage array can enter into an Unstable status. If time is not available, you must restart both controllers, which forces the controllers to write the information.

The volume group and its associated volumes will show an Offline status in the Array Management Window until all of the drives in the volume group are replaced.



IMPORTANT Snapshot volumes do *not* have an Offline status indicator.

These entities show an Offline status:

- **The volume group, the volume, and the snapshot repository volume** – If you move the mouse pointer over the volume group or the volume in the Logical pane of the Array Management Window, a message shows the status as Offline.
 - **The drive needs attention** – If you move the mouse pointer over the drives in the Physical pane of the Array Management Window, a message shows the status as Offline.
7. Depending on whether the drive appears in the Physical pane of the Array Management Window, perform one of these actions:
 - **The drive appears in the Physical pane** – The drive shows a Needs Attention status. Go to step 9.
 - **The drive does not appear in the Physical pane** – Go to step 8.
 8. Reinstall the drive.
 - a. Open the lever, and pull the drive out of the drive tray approximately 5 cm (2 in.).
 - b. Wait at least two minutes for the drive to spin down.
 - c. Install the drive in one complete motion by inserting it all the way into the slot.
 - d. Lower (close) the lever to lock the drive securely in place.
 - e. Wait another two minutes until the drive appears in the Array Management Window before you install the next drive.

The drives show a Needs Attention status in the Physical pane of the Array Management Window until all of the drives from the volume group are installed.
 9. Repeat step 5 through step 7 until all of the drives from the volume group are installed.



IMPORTANT The volume group shows an Offline status until all of the drives are installed. When you install the last drive in the volume group, the volume can show a Failed status temporarily while the controller is updating. When the update is completed, the volume group comes back online automatically with an Optimal status.

10. When all of the drives have been installed, make sure that the volume group is back online by checking the status indicators in the Array Management Window.
 - **The volume group, the volume, and the snapshot repository volume show Optimal status** – If you move the mouse pointer on the volume group or volume in the Logical pane of the Array Management Window, a message shows the status. A snapshot volume has an Optimal status indicator or a Contingent status indicator.
 - **The drive shows Assigned status and Optimal status** – If you move the mouse pointer on the drive in the Physical pane of the Array Management Window, a message shows the status.
11. When the volume group is back online, go to [“Defining New Storage Partitions.”](#)

Defining New Storage Partitions

Perform these steps if you had used Storage Partitioning to define volume-to-LUN mappings for a volume that has been moved to the destination storage array.



IMPORTANT Storage Partitioning is a premium feature that you must enable before you create or change volume-to-LUN mappings.

1. Based on the status of storage partitions, perform one of these actions:
 - **Storage partitions were deleted** – If storage partitions were deleted while the volume group resided in the source storage array, you must create new storage partitions when the volume group is relocated to the destination storage array. If new storage partitions are not defined, hosts connected to the destination storage array are not able to detect the volumes in the new volume group. Go to step 3.
 - **Volume-to-LUN mappings were changed to the Default Group** – Go to step 2.
2. If you changed the host group for specific volume-to-LUN mappings to the Default Group while the volume group resided in the source storage array, perform one of these actions:
 - **You will use default mappings** – The Default Group for the destination storage array detects the volumes when you install the volume group in the destination storage array. Any hosts or host groups in the Default Group of the destination storage array can access the volumes. Go to “[Completing the Volume Group Relocation.](#)”
 - **You will use Storage Partitioning** – You can map a specific host or hosts to the volumes in the destination storage array. Go to step 3.
3. To define a new storage partition, perform these actions:
 - a. Select a volume in the Topology pane of the **Mappings** tab.
 - b. To create a new volume-to-LUN mapping, select **Mappings >> Define >> Storage Partitioning**.
 - c. Follow the instructions on each dialog, and click **Next** when you are ready to move to the next dialog.
 - d. To complete the volume-to-LUN mapping, click **Finish**.
A dialog shows the progress of the processing.
 - e. To return to the **Mappings**, click **OK**.
4. Depending on whether you have additional volumes to map to hosts or host groups, perform one of these actions:
 - **You have additional volumes to map to hosts or host groups** – Repeat step 3.
 - **You are finished mapping volumes to hosts or host groups** – Go to step 5.
5. Run the host hot_add utility, if applicable for your operating system.
6. Go to “[Completing the Volume Group Relocation.](#)”

Completing the Volume Group Relocation

1. Mount any file systems, if applicable, for the operating system.
2. Start the host applications that are associated with the volumes.
3. Create a storage array all support data collection for the source storage array that is affected by the procedure.
 - a. Save the storage array all support data collection.
 - b. Open and view the storage array all support data collection files.

For information about creating a storage array all support data collection, see “[Creating Storage Array All Support Data Collections.](#)”

4. Repeat step 3 for the destination storage array.

Moving a Drive Tray to a Different Storage Array – Data Is Preserved

Relocation Process Overview

 **NOTE** Data is preserved when you successfully follow the procedures listed in this section to move a drive tray from the source storage array to a different destination storage array.

 **NOTE** If you are moving a drive tray that has the DC power option, the destination storage array must be cabled for DC power.

 **WARNING (W14) Risk of bodily injury** – A qualified service person is required to make the DC power connection according to NEC and CEC guidelines.

To move a drive tray with volume groups from one storage array to another storage array, perform these procedures, which are described in detail in the corresponding topics:

1. Locate the drives in a volume group.
 2. Check the status of the source storage array and the destination storage array.
 3. Remove the copy pairs.
 4. Remove the mirror relationships.
 5. Delete a snapshot volume.
 6. Check the NVSRAM bit on the destination storage array.
 7. Change the NVSRAM bit on the destination storage array.
 8. Remove and relocate the drives in the source storage array.
 9. Remove the drive tray from the source storage array.
 10. Turn on the power to the source storage array.
 11. Delete a missing volume.
 12. Install the drive tray into the destination storage array.
 13. Install the drives into the destination storage array.
 14. Define new storage partitions.
 15. Complete the volume group relocation.
-

 **ATTENTION Possible loss of data or data corruption** – Perform a hot volume group relocation whenever possible. This action makes sure that any volume groups or volumes that you move to different destination storage arrays are correctly recognized and managed by the new storage array.

Locating the Drives in a Volume Group

The drives that include a volume group usually are located in multiple drive trays in a storage array. If you move a drive tray from one storage array to another storage array, you are required to identify which volume groups that you want to relocate to the destination storage array. You are also required to identify which volume groups will remain in the source storage array.

You must move the drives that remain in the source storage array to drive trays that will remain within the source storage array. The drives that you want to move to the destination storage array will be installed after the drive tray has been moved to the destination storage array.

1. Based on whether snapshot volumes exist in the volume group, perform one of these actions:
 - **Snapshot volumes exist in the volume group** – Go to step 2.
 - **Snapshot volumes do not exist in the volume group** – Go to step 4.



IMPORTANT If you have created a snapshot volume of a base volume, in some cases, the snapshot repository volume and the base volume might reside in different volume groups. To keep the data in the snapshot volume, you must locate and move all of the volume groups that contain the snapshot repository volumes that are associated with the snapshot volume. If you do not move all of the associated volumes, the snapshot volume will become unusable in both storage arrays.

2. Locate the snapshot repository volume that is associated with the snapshot volume in the volume group that you want to move.
 - a. Open the Enterprise Management Window.
 - b. Select the source storage array in the **Device** table, and start its Array Management Window.

If the Array Management Window for the selected storage array is already open on the storage management station, a second Array Management Window does not open.
 - c. From the Logical pane, right-click a snapshot volume, and select **View Associated Components** from the pop-up menu.
 - d. In the **Volume - Associated Components** dialog, see if the snapshot repository volume is in the same volume group as the snapshot volume.
3. Based on the location of the snapshot repository volume, perform one of these actions:
 - **The snapshot repository volume is in a different volume group** – Repeat step 2 for the volume group that contains the snapshot repository volume. When you have completed these tasks for all of the volume groups, go to step 4.
 - **The snapshot repository volume is in the same volume group** – Go to step 4.
4. Physically locate the drives in the selected volume group by activating the Locate LED on each drive.
 - a. Open the Enterprise Management Window, if necessary.
 - b. Select the source storage array in the **Device** table, and start its Array Management Window.

If the Array Management Window for the selected storage array is already open on the storage management station, a second Array Management Window does not open.
 - c. From the Logical pane, select the volume group.

A blue association dot appears under each drive in the volume group in the Array Management Window.
 - d. Select **Volume Group >> Locate**.

The **Locate Volume Group** dialog appears, and the Locate LEDs blink above or below the drives in the storage array.
5. Physically mark the drives in the storage array to identify whether the drive is part of a volume group that stays in the source storage array or whether the drive is part of a volume group that you want to move to the destination storage array.
6. To stop the blinking LEDs, in the **Locate Volume Group** dialog, click **OK**.
7. Repeat step 1 through step 6 for all of the volume groups that you want to remove from the source storage array.

8. Go to “[Checking the Status of the Source Storage Array and the Destination Storage Array.](#)”

Checking the Status of the Source Storage Array and the Destination Storage Array

1. Make sure that the requirements to move the drives have been met.

For information, see “[Understanding Concepts, Restrictions, and Requirements of Volume Group Relocation.](#)”



IMPORTANT Depending on the size of the storage array, a full backup could take several hours or several days.

2. Make sure that the data that must be preserved on the volume group in the source storage array has been backed up.
3. Make sure that an empty drive tray slot is available in the destination storage array.
4. Determine whether the volume group that you will move from the source storage array contains the volumes that you want to participate in a volume copy.
 - a. Open the Enterprise Management Window.
 - b. Select the source storage array in the **Device** table, and start its Array Management Window.

If the Array Management Window for the selected storage array is already open on the storage management station, a second Array Management Window does not open.
 - c. In the Logical pane, look for any volumes that are a source volume or a target volume that you want to participate in a volume copy.
5. Based on whether volumes that participate in a volume copy exist in the volume group, perform one of these actions:
 - **The volumes that participate in a volume copy exist in the volume group** – Go to “[Removing Copy Pairs.](#)” When you have removed the volume copies from the source storage array, return to step 6 in this procedure.
 - **The volumes that participate in a volume copy do not exist in the volume group** – Go to step 6.
6. Determine whether the volume group that you want to move contains mirror relationships.
 - a. Open the Enterprise Management Window.
 - b. Select the source storage array in the **Device** table, and start its Array Management Window.

If the Array Management Window for the selected storage array is already open on the storage management station, a second Array Management Window does not open.
 - c. In the Logical pane, look for any volumes that are identified with a label as a primary volume or a secondary volume.
7. Based on whether mirror relationships exist in the volume group, perform one of these actions:
 - **Mirror relationships exist in the volume group** – Go to “[Removing the Mirror Relationships.](#)” If you remove mirror relationships from the source storage array, you prevent orphan mirrors on the secondary storage array. When you have removed the mirror relationships, return to step 8 in this procedure.
 - **Mirror relationships do not exist in the volume group** – Go to step 8.
8. Determine whether the volume group that you want to move contains snapshot volumes.
 - a. Open the Enterprise Management Window.
 - b. Select the source storage array in the **Device** table, and start its Array Management Window.

- If the Array Management Window for the selected storage array is already open on the storage management station, a second Array Management Window does not open.
- c. In the Logical pane, look for any volumes that are identified with a label as a snapshot volume.
9. Based on whether snapshot volumes exist in the volume group, perform one of these actions:
- **Snapshot volumes exist in the volume group** – Go to step 10.
 - **Snapshot volumes do not exist in the volume group** – Go to step 11.
-



IMPORTANT If you have created a snapshot volume of a base volume and you do not want to keep the data in the snapshot volume, delete the snapshot volume before you move the volume group.

10. Determine whether the snapshot volumes contain data that you want to keep, and perform one of these actions:
- **Delete the snapshot volumes** – Go to “[Deleting a Snapshot Volume](#).” When you have deleted the snapshot volumes, return to step 11 in this procedure.
 - **Retain the snapshot volumes** – Go to step 11.
11. Check the number of drives in the volume groups that will remain in the source storage array and the number of drives in the volume groups that you want to move to the destination storage array.
- a. Open the Enterprise Management Window.
 - b. Select the source storage array in the **Device** table, and start its Array Management Window.
If the Array Management Window for the selected storage array is already open on the storage management station, a second Array Management Window does not open.
 - c. In the Logical pane, select the volume group.
A blue association dot appears under each drive in the volume group in the Array Management Window.
 - d. Repeat step a through step c for all of the volume groups that you will move to the destination storage array.
12. Make sure that enough empty drive slots are available in the source storage array to accommodate the drives in the volume groups that will remain in the source storage array.
-



IMPORTANT A volume group and its associated standard volumes and snapshot repository volumes must have a status of Optimal in the Logical pane of the Array Management Window before they can be deleted.

13. Check the status of the volume group and its associated volumes in the source storage array.
To view a message that describes the status, move your mouse pointer over the volume group or the volume in the Logical pane.
14. Based on the status of the volume group and the volumes, perform one of these actions:
- **The status is Optimal** – Go to step 17.
 - **The status is Optimal - Operation in Progress** – Go to step 15.
 - **The status is Failed or Degraded** – Go to step 16.
15. If the Optimal - Operating in Progress indicator appears, perform these actions:
- a. Wait for the volume modification operation to complete, which includes these processes:
 - Defragmentation
 - Copyback
 - Initialization

- Dynamic segment sizing
 - Dynamic reconstruction
 - Dynamic RAID-level migration
 - Dynamic capacity expansion
 - Dynamic volume expansion
- b. Make sure that the statuses of the volume group and the volume are Optimal.
 - c. Go to step 17.
16. If a volume or a snapshot repository volume shows a Failed status or a Degraded status, perform these actions:
- a. Use the Recovery Guru to diagnose the problem and to show the appropriate recovery procedure.
 - b. Perform the recovery procedure.
 - c. Make sure that the volume has a status of Optimal.
 - d. Go to step 17.



IMPORTANT You can have global hot spares assigned on the source storage array, but they cannot be in use for the specified volume group. The status of a global hot spare that is assigned but not in use is Standby/Optimal.

If you move the mouse over a global hot spare in the Physical pane of the Array Management Window, a message describes the status.

17. Make sure that global hot spares are not in use for the drives in the volume group that you move from the source storage array.
 - a. Open the Enterprise Management Window.
 - b. Select the source storage array in the **Device** table, and start its Array Management Window.

If the Array Management Window for the selected storage array is already open on the storage management station, a second Array Management Window does not open.
 - c. In the Logical pane, select the appropriate volume group.
 - d. In the Physical pane, make sure that blue association dots do not appear underneath any global hot spares.
18. Based on the status of any global hot spares, perform one of these actions:
 - **Global hot spares are in use for a drive in the volume group** – Use the Recovery Guru to diagnose the problem and to show the appropriate recovery procedure. Perform the recovery procedure, and make sure that global hot spares are not in use. Go to step 19.
 - **Global hot spares are not in use for a drive in the volume group** – Go to step 19.
19. Repeat step 1 through step 18 for all of the volume groups that you want to move.
20. Go to “[Checking the NVSRAM Bit for the Destination Storage Array.](#)”

Removing Copy Pairs

Before you move volumes to participate in a volume copy to the destination storage array, make sure that any copy pairs are removed. This action prevents absent volumes on the destination storage array.



IMPORTANT This option does not delete the source volume or the target volume. Data on the volumes is not affected. As a result of this operation, you can select the target volume as a source volume or a target volume for a new volume copy.

1. Open the Enterprise Management Window.
2. Select the source storage array in the **Device** table, and start its Array Management Window.
If the Array Management Window for the selected storage array is already open on the storage management station, a second Array Management Window does not open.
3. Select **Volume >> Copy >> Copy Manager**.
The **Copy Manager** dialog appears.
4. Select one or more copy pairs in the table.
To select multiple copy pairs, either press **Ctrl** and the left mouse button, or press **Shift** and the left mouse button.
5. Select **Copy >> Remove Copy Pairs**.
The **Remove Copy Pairs** dialog appears.
6. Click **Yes**.
The volume copy is removed.
7. Close the Copy Manager.
8. To complete the verification of the status of the source storage array, return to step 6 in [“Checking the Status of the Source Storage Array and the Destination Storage Array.”](#)

Removing the Mirror Relationships

Before you relocate volumes to participate in a mirror relationship, you must remove the mirror relationship between the primary volumes and the secondary volumes. This action prevents orphan mirrors from existing on the remote storage array.



IMPORTANT This option does not delete the primary volume, the secondary volume, or the mirror repository volumes that support mirroring for the storage arrays. Data on the volumes is not affected.

As a result of this operation, the primary volume and the secondary volume become standard, host accessible, non-mirrored volumes.

1. Open the Enterprise Management Window.
2. Select either the primary storage array or the secondary storage array in the **Device** table, and start its Array Management Window.
If the Array Management Window for the selected storage array is already open on the storage management station, a second Array Management Window does not open.
3. In the Logical pane, select the primary volume or the secondary volume that is participating in the mirror relationship.
4. Select **Volume >> Remote Volume Mirroring >> Remove Mirror Relationship**.
The **Remove Mirror Relationship** dialog appears.
5. From the **Select one or more mirrored pairs** list, select the mirrored volume pairs for which you want to remove the mirror relationship.
To select multiple mirrored pairs, either press **Ctrl** and the left mouse button, or press **Shift** and the left mouse button. To select all of the mirrored pairs, click the **Select All** button.

6. Click **OK**.
The **Remove Mirror Relationship - Confirmation** dialog appears.
7. Click **Yes**.
The **Remove Mirror Relationship - Progress** dialog appears. When the mirror relationship is removed, the volumes in the mirrored pairs that you selected are no longer part of a mirror relationship. All data on the volumes stays intact and available. Secondary volumes become accessible by hosts that are mapped to them.
8. To complete the verification of the status of the source storage array, return to step 8 in [“Checking the Status of the Source Storage Array and the Destination Storage Array.”](#)

Deleting a Snapshot Volume



ATTENTION Possible loss of data – If you delete a volume group and its drives, all data is removed, which includes snapshot volumes and their associated snapshot repository volumes. The associated drives return to an Unassigned status. *You cannot cancel this operation after it starts.* Use this option only if you do not want to keep the data or the volume information about the drives.



IMPORTANT Depending on the size of the storage array, a full backup could take several hours or several days.

1. Back up any data on the volume.
2. Stop I/O activity to the source storage array, and unmount all of the file systems.
You cannot delete a volume that is part of a volume group that contains a drive that is performing a copyback operation.
3. Open the Enterprise Management Window.
4. Select the source storage array in the **Device** table, and start its Array Management Window.
If the Array Management Window for the selected storage array is already open on the storage management station, a second Array Management Window does not open.
5. Make sure that the status of the snapshot volume is Optimal or Failed.
6. In the Logical pane, select the snapshot volume that you want to delete.
7. Select **Volume >> Delete**.
To select multiple snapshot volumes, either press **Ctrl** and the left mouse button, or press **Shift** and the left mouse button.
The **Delete Volumes** dialog appears.
8. Click **Delete**.
A confirmation dialog appears.
9. Type **yes**, and click **OK**.
For information about snapshot volumes, refer to the online help topics in the Array Management Window.
The **Delete Volume - Progress** dialog appears while the snapshot volume and its associated snapshot repository volume are deleted. The free capacity in the volume group increases or additional unconfigured capacity becomes available.
10. If additional snapshot volumes are to be deleted, repeat step 5 through step 9.
11. If you see a system error message that relates to the deleted volume, either reconfigure your host system, or restart your host system to permanently remove any system information about the volume.

12. To complete the verification of the status of the source storage array, return to step 11 in [“Checking the Status of the Source Storage Array and the Destination Storage Array.”](#)

Checking the NVSRAM Bit for the Destination Storage Array

You must check the setting of the Disable Drive Migration feature bit (bit 1 in offset x35) in the NVSRAM on the destination storage array before you can move the drives. Use the **Script Editor** dialog in the Enterprise Management Window to check the setting.

Before you install volume groups that contain data that must be preserved, you must clear the Disable Drive Migration feature bit (set it to 0) on the destination storage array.

1. Open the Enterprise Management Window, if necessary.
2. Select the destination storage array in the Device Tree view or the Device table.
3. Select **Tools >> Execute Script**.
4. In the upper pane of the **Script Editor** dialog, type these statements. Press **Enter** after each statement.

```
show controller [a] NVSRAMByte [0x35];
```

```
show controller [b] NVSRAMByte [0x35];
```

5. To run the script, from the menu bar on the **Script Editor** dialog, select **Tools >> Execute Only**.

The current hexadecimal value of the Disable Drive Migration feature bit appears in the lower pane of the **Script Editor** dialog.

```
Controller "a" NVSRAM offset 0x35 = byte_value.
```

```
Controller "b" NVSRAM offset 0x35 = byte_value.
```

In these commands, *byte_value* = 0 enables drive migrations, or *byte_value* = 1 disables drive migrations.

6. Depending on the value of *byte_value* that is returned from each controller, perform one of these actions:
 - **The byte value returned from each controller is 0x00** – The Disable Drive Migration feature bit is cleared. Go to [“Changing the NVSRAM Bit for the Destination Storage Array.”](#)
 - **The byte value returned is any value other than 0x00** – You must determine the Disable Drive Migration feature bit value by using the Disable Drive Migration feature bit as bit 1 of this NVSRAM offset. If you do not know how to perform this operation, contact the next level of support for instruction.

Changing the NVSRAM Bit for the Destination Storage Array

Before you install the drives from the source storage array into the destination storage array, you must clear the Disable Drive Migration feature bit (set it to 0) on the destination storage array. Use the **Script Editor** in the Enterprise Management Window to change the setting.



IMPORTANT After you clear the Disable Drive Migration feature bit (set it to 0), you must power off and power on the entire storage array of the controller tray or the controller-drive tray.

1. Stop I/O activity to the destination storage array, and unmount all file systems.
2. Is the **Script Editor** dialog Open?

- **Yes** – Select **File >> New Script**. Go to step 6.
 - **No** – Go to step 3.
3. Open the Enterprise Management Window, if necessary.
 4. Select the destination storage array in the Device Tree view or the Device table.
 5. Select **Tools >> Execute Script**.
 6. Type these statements in the upper window in the **Script Editor** dialog. Press **Enter** after each statement.

```
set controller [a] NVSRAMByte [0x35] = 0x00;
```

```
set controller [b] NVSRAMByte [0x35] = 0x00;
```

7. To run the script, from the menu bar on the **Script Editor** dialog, select **Tools >> Execute Only**.
8. Turn off the power to the controller tray or the controller-drive tray.
9. Wait 20 seconds, and turn on the power to the controller tray or the controller-drive tray.



NOTE After you turn on the power to the controller tray or the controller-drive tray, wait for the controllers to finish booting before proceeding to the next step.

10. To show the current hexadecimal values for the Disable Drive Migration feature bit, type these statements in the upper pane of the **Script Editor** dialog. Press **Enter** after each statement.

```
show controller [a] NVSRAMByte [0x35];
```

```
show controller [b] NVSRAMByte [0x35];
```

11. To run the script, from the menu bar on the **Script Editor** dialog, select **Tools >> Execute Only**.
12. Make sure that the current hexadecimal value of the Disable Drive Migration feature bit is set to 0.
The current hexadecimal value of the Disable Drive Migration feature bit appears in the lower pane of the **Script Editor** dialog.
13. To close the **Script Editor** dialog, select **File >> Exit**.
14. To close the confirmation dialog and to return to the Enterprise Management Window, click **No**.
15. Go to [“Removing and Relocating the Drives.”](#)

Removing and Relocating the Drives

In some cases, the drives that comprise a volume group might be split between a drive tray that you are moving and another drive tray that will remain in the source storage array. This procedure applies to two such situations:

- A drive tray that you are moving contains some drives that belong to a volume group that will remain in the source storage array. Move those drives to another drive tray in the source storage array.
- A volume group you are moving to the destination storage array has some drives in a drive tray that you are moving and others in a drive tray that will remain in the source storage array. Move the drives that are needed for the volume group that you are moving. Move those drives from the drive tray that remains in the source storage array to a drive tray in the destination storage array.

If the drive trays you are moving contain all of the drives used by the volume groups you are moving and contain no drives used by other volume groups, go to "[Moving the Drive Trays from the Source Storage Array to the Destination Storage Array.](#)"

If the volume group contains snapshot volumes and the base volume and the snapshot repository volumes are located in different volume groups, the preferred order to move the volumes is as follows:

- First, remove the volume group with the base volume from the storage array.
 - Second, remove the volume group with the snapshot repository volume.
1. Create a storage array all support data collection for the source storage arrays affected by the procedure.
 - a. Save the storage array all support data collection.
 - b. Open and view the storage array all support data collection files.

For information about creating a storage array all support data collection, see "[Creating Storage Array All Support Data Collections.](#)"

2. Stop I/O activity to the source storage array, and unmount all of the file systems. You can relocate drive trays in two ways:
 - **Cold drive tray relocation** – Go to step 3.
 - **Warmdrive tray relocation** – Go to step 5.
3. Turn off the power to the controller tray or the controller-drive tray.
4. Turn off the power to the drive trays.



ATTENTION Possible hardware damage – To prevent electrostatic discharge damage to the tray, use proper antistatic protection when handling tray components.

5. Put on antistatic protection.



ATTENTION Possible damage to drives – Bumping drives against another surface can damage the drive mechanism or connectors. To avoid damage when removing or installing a drive, always place your hand under the drive canister to support its weight. Do not touch the electronics on the drive.

6. Open the lever on the drive canister that you want to relocate, and pull the drive out of the drive tray.
Make sure that you put your hand under the drive to support its weight when you remove it from the drive tray.
7. Put the drive on an antistatic, cushioned surface away from magnetic fields.
8. Repeat step 6 through step 7 for each drive that you want to move.
9. Install the drive into a empty drive slot. Install the drive in one complete motion by inserting it all the way into the slot, and then lowering (closing) the lever to lock the drive securely into place.
10. Repeat step 9 until all of the drives have been relocated.



IMPORTANT To maintain correct airflow in the drive tray, you must fill all of the drive slots. If you do not have a drive for a drive slot, insert a blank drive canisters in that slot.

11. Insert blank drive canisters into all empty drive slots in the drive trays.
12. Go to "[Moving the Drive Trays from the Source Storage Array to the Destination Storage Array.](#)"

Moving the Drive Trays from the Source Storage Array to the Destination Storage Array

 **ATTENTION Possible hardware damage** – To prevent electrostatic discharge damage to the tray, use proper antistatic protection when handling tray components.

 **IMPORTANT** If components of your storage array have the DC-power option, keep in mind that the procedures for disconnecting and connecting power cables for those components are different. For information on DC power connections, refer to the topics under Storage Array Installation that apply to your storage array or the corresponding PDF document on the SANtricity ES Storage Manager Installation DVD.

1. Did you perform the procedure in "[Removing and Relocating the Drives](#)"?
 - **Yes** - Go to step 7.
 - **No** - Go to step 2.
 2. Create a storage array all support data collection for the source storage arrays affected by the procedure.
 - a. Save the storage array all support data collection.
 - b. Open and view the storage array all support data collection files.
For information about creating a storage array all support data collection, see "[Creating Storage Array All Support Data Collections](#)."
 3. Stop I/O activity to the source storage array, and unmount all of the file systems.
 4. Turn off the power to the controller tray or the controller-drive tray.
 5. Turn off the power to the drive trays.
-

 **ATTENTION Possible hardware damage** – To prevent electrostatic discharge damage to the tray, use proper antistatic protection when handling tray components.

6. Put on antistatic protection.
-

 **WARNING (W14) Risk of bodily injury** – A qualified service person is required to make the DC power connection according to NEC and CEC guidelines.

7. Disconnect the power cords.
8. Disconnect and label the drive interface cables between the drive tray that you want to move and the drive trays that will remain in the source storage array.
9. Remove the side covers from the front of the drive tray, if needed.
10. Use a screwdriver to unsnap the front bezel from the mounting pins on the drive tray.
11. Install mounting rails in the cabinet of the destination storage array, if needed.
12. Remove the mounting screws from the drive tray.
Depending on the weight of your drive tray, you may need more than one person to move the drive tray.

 **WARNING (W08) Risk of bodily injury –**



>18 kg (39.7 lbs)

Two persons are required to safely lift the component.

 **WARNING (W09) Risk of bodily injury –**



>35 kg (70.5 lbs)

Three persons are required to safely lift the component.

13. Pull the drive tray out of the cabinet, and move the drive tray to the destination storage array. Move any associated hardware, such as mounting screws, bezel and end caps, with the drive tray.
14. Set the Tray ID switches on the drive tray, if necessary. For instructions for your drive tray model, refer to the topics under Storage Array Installation that apply to your storage array or the corresponding PDF document on the SANtricity ES Storage Manager Installation DVD.
15. At the front of the destination cabinet, set the drive tray on the mounting rails, and slide it all the way into the cabinet.
16. Secure the drive tray in the cabinet.
 - a. Align the front mounting holes on each side of the drive tray with the mounting holes on the front of the mounting rails.
 - b. Secure the front of the drive tray to the cabinet rails by inserting screws into the bottom holes.
 - c. Secure the rear of the drive tray with two screws, one on each side.
17. Reinstall all of the associated hardware that you moved in step 13.
18. Repeat step 2 through step 13 until all of the drive trays have been moved.
19. Cable the drive connections in the source storage array for the new configuration of drive trays. For the correct cabling configuration, refer to the topics under *Hardware Cabling* or to the corresponding PDF document on the SANtricity ES Storage Manager Installation DVD.
20. Cable the drive connections in the destination storage array for the new configuration of drive trays. For the correct cabling configuration, refer to the topics under *Hardware Cabling* or to the corresponding PDF document on the SANtricity ES Storage Manager Installation DVD.
21. Go to [“Turning On the Power to the Source Storage Array.”](#)

Turning On the Power to the Source Storage Array

 **IMPORTANT** Some controller trays or controller-drive trays do not acknowledge any attached drive trays that are turned on after the power is turned on to the controller tray or the controller-drive tray. You must turn on the power to the drive trays before you turn on the power to the controller tray or the controller-drive tray.

1. Make sure that all interface cables and power cords are connected securely to the controller tray or the controller-drive tray and any attached drive trays.
-

 **WARNING (W14) Risk of bodily injury** – A qualified service person is required to make the DC power connection according to NEC and CEC guidelines.

2. Turn on the Power switches to all of the drive trays that are connected to the controller tray or the controller-drive tray.
3. After all of the drives in the drive trays have started, turn on both Power switches on the rear of the controller tray or the controller-drive tray.

The green and amber LEDs on the front and rear of the drive trays and the controller trays or controller-drive trays blink during the power-on process.

The battery canister in the controller tray or the controller-drive tray might take up to 15 minutes to complete its self-test. For detailed information on LED indications while a battery is recharging, refer to the topics under Storage Array Installation that apply to your storage array or to the corresponding PDF document on the SANtricity ES Storage Manager Installation DVD.

4. Check the LEDs on the front and rear of the controller tray or the controller-drive tray and the drive trays.

Under normal operating conditions, all green Power LEDs are on and all amber Service Action Required LEDs are off. For detailed views and descriptions of each of the LEDs, refer to the topics under Storage Array Installation that apply to your storage array or to the corresponding PDF document on the SANtricity ES Storage Manager Installation DVD.

5. Open the Enterprise Management Window, if necessary.
6. Select the source storage array in the **Device** table, and start its Array Management Window.

If the Array Management Window for the selected storage array is already open on the storage management station, a second Array Management Window does not open.

 **IMPORTANT** After a volume group has been removed from the storage array while still powered on, you can see missing volumes in the Logical pane of the Array Management Window. For information about missing volumes, refer to the online help topics in the Array Management Window.

 **IMPORTANT** If the storage array was powered off during the drive tray relocation, the source storage array does not show the missing volumes in the Logical pane of the Array Management Window.

7. Determine whether any missing volumes are associated with the volume groups that you have removed.
 - a. Open the Enterprise Management Window.
 - b. Select the source storage array in the **Device** table, and start its Array Management Window.

If the Array Management Window for the selected storage array is already open on the storage management station, a second Array Management Window does not open.
 - c. In the Logical pane, check whether any missing volumes are associated with the volume groups that were relocated to the destination storage array.

- d. Use the storage array all support data collection to identify the World Wide Identifier (WWID) for the volume.
8. Based on the status of any missing volumes, perform one of these actions:
 - **The missing volumes are associated with a volume group that you moved to the destination storage array** – Go to [“Deleting a Missing Volume.”](#) After you have deleted the missing volume, return to step 7 in this procedure.
 - **The missing volumes are *not* associated with a volume group that you moved to the destination storage array** – Go to step 9.
 9. Make sure that all of the volume groups are online with Optimal status by checking the status indicators in the Array Management Window:
 - **The volume group, the volume, and the snapshot repository volume show Optimal statuses** – If you move the mouse pointer over the volume group or the volume in the Logical pane of the Array Management Window, a message describes the status. A snapshot volume will have an Optimal status indicator or a Contingent status indicator.
 - **The drive shows Assigned and Optimal statuses** – If you move the mouse pointer over the drive in the Physical pane of the Array Management Window, a message describes the status.
 10. Based on the status of the volume group and the volume, perform one of these actions:
 - **The status is Optimal** – Go to [“Installing the Drive Trays into the Destination Storage Array.”](#)
 - **The status is Optimal - Operation in Progress** – Go to step 11.
 - **The status is anything other than Optimal or Optimal - Operation in Progress** – Go to step 12.
 11. The Optimal - Operation in Progress status indicator appears. Perform these actions:
 - a. Wait for the volume modification operation to complete, which includes these processes:
 - Defragmentation
 - Copyback
 - Initialization
 - Dynamic segment sizing
 - Dynamic reconstruction
 - Dynamic RAID-level migration
 - Dynamic capacity expansion
 - Dynamic volume expansion
 - b. Make sure that the volume group and the volumes have Optimal statuses.
 - c. Go to [“Installing the Drive Trays into the Destination Storage Array.”](#)
 12. Check the status of the volume groups, and perform one of these actions:
 - **The volume groups are Offline** – Make sure that the status indicators are Optimal for the volume group and associated volumes. Go to [“Installing the Drive Trays into the Destination Storage Array.”](#)
 - **Use the Recovery Guru to diagnose the problem and present the appropriate recovery procedure** – Perform the recovery procedure, and make sure that the status indicators are Optimal for the volume group and its associated volumes. Go to [“Installing the Drive Trays into the Destination Storage Array.”](#)

Deleting a Missing Volume

Complete this procedure to delete a missing volume that is associated with a volume group that you want to relocate to the destination storage array.

1. Open the Enterprise Management Window, if necessary.
2. Select the destination storage array in the **Device** table, and start its Array Management Window.

If the Array Management Window for the selected storage array is already open on the storage management station, a second Array Management Window does not open.

3. From the Logical pane, locate the missing volume.
4. Use the storage array all support data collection to identify the World Wide Identifier (WWID) for the volume.



ATTENTION Possible loss of data – If you delete a missing volume, this action permanently removes the volume from the configuration. Any associated snapshot volumes, snapshot repository volumes, or volume-to-LUN mappings are also deleted. Do *not* delete any missing volumes before you confirm that the volumes are no longer required. For information about absent volumes, refer to the online help topics in the Array Management Window.

5. Make sure that the missing volume is no longer required. If you delete the missing volume, you permanently remove it from the configuration.
6. Delete any missing volumes that are associated with the volume group that you want to move to the destination storage array.
 - a. Select a missing volume in the Logical pane.
 - b. Select **Volume >> Delete**.

The **Delete Volumes** dialog appears.
 - c. Click **Delete**.

The **Confirm Delete Volume(s)** dialog appears.
 - d. To permanently delete the missing volume from the configuration, type *yes*, and click **OK**.

If this is the last absent volume under the Missing Volumes Group node, the Missing Volumes Group node also is removed.
7. If you must delete other missing volumes, repeat step 3 through step 6.
8. If system error messages that relate to the deleted volume appear, reconfigure your host system or restart your host system to permanently remove any system information about the volume.
9. To complete the procedure to remove drives from the source storage array, return to step 7 in [“Moving the Drive Trays from the Source Storage Array to the Destination Storage Array.”](#)

Installing the Drive Trays into the Destination Storage Array



ATTENTION Possible hardware damage – To prevent electrostatic discharge damage to the tray, use proper antistatic protection when handling tray components.



IMPORTANT If components of your storage array have the DC-power option, keep in mind that the procedures for disconnecting and connecting power cables for those components are different. For information on DC power connections, refer to the topics under Storage Array Installation that apply to your storage array or the corresponding PDF document on the SANtricity ES Storage Manager Installation DVD.

1. Put on antistatic protection.
2. Connect the drive interface cables between the current drive trays in the destination storage array and the newly installed drive tray. For the correct cabling configuration, refer to the topics under *Hardware Cabling* or to the corresponding PDF document on the SANtricity ES Storage Manager Installation DVD.

3. To maintain power redundancy, connect each power supply in the drive tray to a separate power source in the cabinet.



WARNING (W14) Risk of bodily injury – A qualified service person is required to make the DC power connection according to NEC and CEC guidelines.

4. For each additional drive tray to be moved, repeat step 2 through step 3.
5. Turn on the power to the drive trays.
6. Start the Array Management Window for the storage array.
The newly installed drive tray is visible in the Physical pane with empty drive slots.
7. Go to “[Installing the Drives into the Destination Storage Array.](#)”

Installing the Drives into the Destination Storage Array

When you complete this procedure, the drives come online automatically in the storage array.



IMPORTANT Volume group numbering on the destination storage array might change after all of the drives in the volume group are installed. The controller automatically assigns volume group numbering for current volume groups and relocated volume groups.

If you have created a snapshot volume of a base volume, in some cases, the snapshot repository volume and the base volume might reside in different volume groups. If you want to keep the data in the snapshot volume, you must locate and move all of the volume groups that contain the snapshot repository volumes that associated with the snapshot volume. If you do not move all of the associated volumes, the snapshot volume will become unusable in both storage arrays.

-
1. Open the Enterprise Management Window.
 2. Select the destination storage array in the **Device** table, and start its Array Management Window.
If the Array Management Window for the selected storage array is already open on the storage management station, a second Array Management Window does not open.
 3. Make sure that empty drive slots are available in the Physical pane of the Array Management Window for the destination storage array.



ATTENTION Possible hardware damage – To prevent electrostatic discharge damage to the tray, use proper antistatic protection when handling tray components.

4. Put on antistatic protection.
5. Remove the blank drive canisters from the empty drive slots.



ATTENTION Possible damage to drives – If you bump drives against another surface, the drive mechanism or connectors can be damaged. To avoid damage when you remove or install a drive, always put your hand under the drive canister to support its weight. Do not touch the electronics on the drive.

6. Install the drive canisters, one at a time, into the destination storage array.
 - a. Install each drive in one complete motion by inserting it all the way into the slot.
 - b. Lower (close) the lever to lock the drive securely into place.

 **IMPORTANT** Wait at least two minutes for the controller to write information before you reinstall the next drive. If you install more than one drive and the controller is not given enough time to recognize each drive, the storage array can enter into an Unstable status. If time is not available, you must restart both controllers, which forces the controllers to write the information.

The volume group and its associated volumes will show an Offline status in the Array Management Window until all the drives in the volume group are replaced.

 **IMPORTANT** Snapshot volumes do *not* have an Offline status indicator.

These entities show an Offline status:

- **The volume group, the volume, and the snapshot repository volume** – If you move the mouse pointer over the volume group or the volume in the Logical pane of the Array Management Window, a message shows the status as Offline.
 - **The drive needs attention** – If you move the mouse pointer over the drives in the Physical pane of the Array Management Window, a message shows the status as Offline.
7. Depending on whether the drive appears in the Physical pane of the Array Management Window, perform one of these actions:
 - **The drive appears in the Physical pane** – The drive shows a Needs Attention status. Go to step 9.
 - **The drive does not appear in the Physical pane** – Go to step 8.
 8. Reinstall the drive.
 - a. Open the lever, and pull the drive out of the drive tray approximately 5 cm (2 in.).
 - b. Wait at least two minutes for the drive to spin down.
 - c. Install the drive in one complete motion by inserting it all the way into the slot.
 - d. Lower (close) the lever to lock the drive securely in place.
 - e. Wait another two minutes until the drive appears in the Array Management Window before you install the next drive.

The drives show a Needs Attention status in the Physical pane of the Array Management Window until all of the drives from the volume group are installed.
 9. Repeat step 5 through step 7 until all of the drives from the volume group are installed.
-

 **IMPORTANT** The volume group shows an Offline status until all of the drives are installed. When you install the last drive in the volume group, the volume can show a Failed status temporarily while the controller is updating. When the update is completed, the volume group comes back online automatically with an Optimal status.

10. When all of the drives have been installed, make sure that the volume group is back online by checking the status indicators in the Array Management Window.
 - **The volume group, the volume, and the snapshot repository volume show Optimal status** – If you move the mouse pointer on the volume group or volume in the Logical pane of the Array Management Window, a message shows the status. A snapshot volume has an Optimal status indicator or a Contingent status indicator.
 - **The drive shows Assigned status and Optimal status** – If you move the mouse pointer on the drive in the Physical pane of the Array Management Window, a message shows the status.
11. When the volume group is back online, go to “[Defining New Storage Partitions.](#)”

Defining New Storage Partitions

Perform these steps if you had used Storage Partitioning to define volume-to-LUN mappings for a volume that has been moved to the destination storage array.



IMPORTANT Storage Partitioning is a premium feature that you must enable before you create or change volume-to-LUN mappings.

1. Based on the status of storage partitions, perform one of these actions:
 - **Storage partitions were deleted** – If storage partitions were deleted while the volume group resided in the source storage array, you must create new storage partitions when the volume group is relocated to the destination storage array. If new storage partitions are not defined, hosts connected to the destination storage array are not able to detect the volumes in the new volume group. Go to step 3.
 - **Volume-to-LUN mappings were changed to the Default Group** – Go to step 2.
2. If you changed the host group for specific volume-to-LUN mappings to the Default Group while the volume group resided in the source storage array, perform one of these actions:
 - **You will use default mappings** – The Default Group for the destination storage array detects the volumes when you install the volume group in the destination storage array. Any hosts or host groups in the Default Group of the destination storage array can access the volumes. Go to [“Completing the Volume Group Relocation.”](#)
 - **You will use Storage Partitioning** – You can map a specific host or hosts to the volumes in the destination storage array. Go to step 3.
3. To define a new storage partition, perform these actions:
 - a. Select a volume in the Topology pane of the **Mappings** tab.
 - b. To create a new volume-to-LUN mapping, select **Mappings >> Define >> Storage Partitioning**.
 - c. Follow the instructions on each dialog, and click **Next** when you are ready to move to the next dialog.
 - d. To complete the volume-to-LUN mapping, click **Finish**.
A dialog shows the progress of the processing.
 - e. To return to the **Mappings** tab, click **OK**.
4. Depending on whether you have additional volumes to map to hosts or host groups, perform one of these actions:
 - **You have additional volumes to map to hosts or host groups** – Repeat step 3.
 - **You are finished mapping volumes to hosts or host groups** – Go to step 5.
5. Run the host hot_add utility, if applicable for your operating system.
6. Go to [“Completing the Volume Group Relocation.”](#)

Completing the Volume Group Relocation

1. Mount any file systems, if applicable, for the operating system.
2. Start the host applications that are associated with the volumes.
3. Create a storage array all support data collection for the source storage array that is affected by the procedure.
 - a. Save the storage array all support data collection.
 - b. Open and view the storage array all support data collection files.

For information about creating a storage array all support data collection, see “[Creating Storage Array All Support Data Collections](#).”

4. Repeat step 3 for the destination storage array.

System Upgrade for Hardware and Software

These topics describe a range of procedures for upgrading hardware, software, and firmware.

Preparing to Upgrade Your Storage Management Software

The topics in this section include the procedure for upgrading the SANtricity ES Storage Manager. The topics also cover background information about hardware and software configurations that you need to understand for subsequent upgrade procedures.

Upgrading the Storage Array to SANtricity ES Storage Manager Version 10.75

Prerequisite: These steps are required for a successful upgrade from storage management software Version 8.4x or later to Version 10.75 (controller firmware version 5.3x to version 7.75). Perform the steps in order.

1. Make sure that the controller trays and the controller-drive trays in your storage array are compatible with the software level and the firmware level to which you are upgrading.

See "[Supported Trays and the Maximum Number of Drives and Volumes](#)" for version information.

2. Check that the host bus adapters (HBAs), switches, driver versions, firmware levels, and specific hardware restrictions are supported.



IMPORTANT Install all storage area network (SAN) hardware before you work with the storage management software.

3. Start the existing storage management software with the procedure for your operating system.
4. Check that the storage array has Optimal status.
5. Save and print the storage array profile from the current Array Management Window of the storage management software for each storage array.
 - a. In the Array Management Window, select **Storage Array >> View >> Profile**.
 - b. Click **Save As**.
 - c. Select the **All sections** radio button.
 - d. Type a file name in the **File name** text box.
 - e. Click **Save**.

The storage array profile is used for this information:

- Configuration information that you might provide to your Customer and Technical Support representative
- The current NVSRAM and controller firmware versions
- The current environmental services monitor (ESM) firmware version

6. Locate the cache and processor memory size (MB) in the storage array profile, and record the listed size for later verification.
7. Locate the host interface in the storage array profile, and record the number listed in the Preferred ID area for each Fibre Channel interface for later verification.
8. Make sure that your storage array has the minimum system requirements for your operating system.

See "[Required Computing Environment](#)."
9. Make sure that your failover driver is compatible with the new hardware, firmware, and software. Refer to the topics under *SANtricity ES Storage Manager Failover Drivers for Version 10.75* or to the SANtricity ES Storage Manager Installation DVD for the corresponding PDF document.



NOTE Read the "dependence" section in the SANtricity ES Storage Manager `readme.txt` file.

10. Make sure that the current version of the storage management software can be upgraded to SANtricity ES Storage Manager Version 10.75.
11. Install SANtricity ES Storage Manager Version 10.75 for your operating system (OS). Use the procedure for your OS to install the storage management software.
12. Make sure that the installation was successful. Use the procedure for your operating system to start the storage management software.
13. Check that the storage array has an Optimal status. If one or more managed devices has a Needs Attention status, contact your Customer and Technical Support representative.
14. If you determined from the storage array profile that the NVSRAM firmware, the controller firmware, or the ESM firmware is not the current version, download the compatible firmware.



NOTE You can upgrade from RAID Core 1 to RAID Core 2, by using the Enterprise Management Window. See [“Upgrading the Firmware and the NVSRAM.”](#)

Software Packages

All SANtricity ES Storage Manager software packages are generally installed in the same directory on the same system, whether the system is a host or a separate storage management station.

SANtricity ES Storage Manager Software Packages

| Software Package | Description and Usage |
|---|---|
| SMclient | This package contains the graphical user interface for managing the storage array. This package also contains an optional monitor service that sends alerts when a critical problem exists with the storage array. |
| SMagent | The storage management software that is installed only on a host system to enable in-band management.* |
| SMruntime | The operating system (OS) -specific storage management software that installs the appropriate Java runtime environment (JRE), which allows Java files to be displayed. |
| Redundant Dual Active Controller (RDAC) | A multi-path failover driver, proprietary to LSI, that is installed on Linux hosts. This software package manages the I/O paths into the controllers in the storage array. If a problem exists on the path or a failure occurs on one of the controllers, the driver automatically reroutes the request from the hosts to the other controller in the storage array. For information about other supported failover drivers for your operating system, refer to the topics under <i>SANtricity ES Storage Manager Failover Drivers for Version 10.75</i> or to the SANtricity ES Storage Manager Installation DVD for the corresponding PDF document. |
| SMutil | This package contains utilities that let the operating system recognize the volumes that you create in the storage array and to view the OS-specific device names for each volume. |

| Software Package | Description and Usage |
|--|--|
| SMprovider | The storage management software interface to the Volume Shadow Copy Service (VSS) and Virtual Disk Service (VDS) technologies (these technologies are included with Microsoft's .NET framework). |
| SMinstaller | A package that installs the InstallAnywhere utility. |
| Support Monitor Profiler | This package helps you to collect the support data and email the support data to the Customer and Technical Support representative. |
| <p>* In-band management is a method for managing a storage array in which the controllers are managed from a storage management station attached to a host that is running host-agent software. The host-agent software receives communication from the storage management client software and passes it to the storage array controllers along a Fibre Channel input/output (I/O) path. The controllers also use the I/O connections to send event information back to the storage management station through the host.</p> | |

 **NOTE** The Microsoft Virtual Disk Service (VDS) and Volume Shadow Copy Service (VSS) providers are a part of the SANtricity ES Storage Manager package for the Windows Server 2003 OS and the Windows Server 2008 OS.

Installation Options

Install only the packages that are required for the type of installation you are performing.

Installation Options and Related Software Packages

| Installation Option | SMruntime | SMclient | SMutil | SMagent | RDAC Failover Driver* | Support Monitor Profiler |
|---|-----------|----------|--------|---------|-----------------------|--------------------------|
| Typical installation | X | X | X | X | | X |
| Storage management station** | X | X | | | | X |
| Host station | X | | X | | X | |
| A host station acting as a storage management station (out-of-band management)*** | X | X | X | | X | |
| Host with in-band management | X | | X | X | X | |

| Installation Option | SMruntime | SMclient | SMutil | SMagent | RDAC Failover Driver* | Support Monitor Profiler |
|--|-----------|----------|--------|---------|-----------------------|--------------------------|
| Custom (you can select the software packages) | | | | | | |
| <p>* The RDAC failover driver is proprietary to LSI and is available for download to the Linux OS. ** The storage management station is a computer that runs storage management software that adds, monitors, and manages the storage arrays on a network. *** Out-of-band management is a method to manage a storage array directly over the network through an Ethernet connection, from a storage management station that is attached to the controllers. This management method lets you configure the maximum number of volumes supported by your operating system and host adapters.</p> | | | | | | |

Checking the Current Version of the Storage Management Software

To check the level of the current storage management software, type the command that corresponds to your operating system, and press **Enter**. The *<package_name>* placeholder refers to the name of the software package that is installed.

Some operating system-specific commands are listed as follows:

- In the HP-UX operating system, type `swlist | grep SM*`, and press **Enter**.
- In the AIX operating system, type `lspp -L <package_name>`, and press **Enter**.
- In the Solaris operating system, type `pkginfo -l <package_name>`, and press **Enter**.
- In the Linux operating system, type `rpm -qi <package_name>`, and press **Enter**.
- In the Windows operating system, perform these tasks:
 1. Select **Start >> Run**.
 2. Type `regedit`, and press **Enter**.
The **Register Editor** window appears.
 3. Perform one of these actions:
 - In Windows XP operating system, select **HKEY_LOCAL_MACHINE >> SOFTWARE >> Storage**.
 - In Windows Server 2003 and Windows Server 2008 operating systems, select **HKEY_LOCAL_MACHINE >> SOFTWARE >> Wow6432Node >> Storage**.
 4. Select a software package listed under the storage directory to view the version.

You can also check the version of the storage management software in the Enterprise Management Window or the Array Management Window by selecting **Help >> About**.

Controller Trays and Controller-Drive Trays

This section describes the supported controller trays and controller-drive trays.

Controller Trays and Controller-Drive Trays

| Term | Description |
|-----------------------|--|
| Controller tray | A unit that contains one or two controllers, batteries (optional), and redundant cooling fans and power supplies. Controller trays do not contain environmental services monitors (ESMs). |
| Controller-drive tray | A unit that contains drives, batteries (optional), redundant cooling fans and power supplies, and (depending on the model) one or two controllers. Controller-drive trays do not contain ESMs. |

Supported Trays and the Maximum Number of Drives and Volumes

The following table shows the controller-drive trays, the controller trays, and the versions of the supported storage management software. This table also shows the maximum number of drives and the total number of volumes that are supported by each controller tray or controller-drive tray. The total numbers include drives or volumes that are contained in the controller tray or the controller-drive tray and in additional attached drive trays.

Supported Trays and the Maximum Number of Drives and Volumes

| Tray Name | Controller Type | Version of the Storage Management Software | Maximum Drives per Storage Array | Maximum Volumes per Storage Array* |
|-------------------------------|-----------------|---|----------------------------------|------------------------------------|
| Controller-drive trays | | | | |
| SHV2200 or SHV2500 | 2772 | 8.30 | 42 | 512 |
| SHV2520 | 2880 (dual) | 8.33, 8.40, 9.10, 9.12, 9.19, 9.23, 10.10 | 14** | 1024 |
| SHV2600 | 2882 | 8.33, 8.40, 9.10, 9.12, 9.19, 9.23, 10.10 | 112 | 1024 |
| SAT2700 | 2820-SATA | 8.42, 9.12 | 14** | 512 |
| SAT2800 | 2822-SATA | 8.42, 9.12 | 112 | 512 |
| AM1331and AM1333 | 1331/1333 | 9.23, 9.30, 9.60, 9.70, 10.30, 10.35, 10.36, 10.50, 10.60 | 48 | 256 |
| AM1532 | 1532 | 9.70, 10.30, 10.35, 10.36, 10.50, 10.60 | 48 | 256 |

| Tray Name | Controller Type | Version of the Storage Management Software | Maximum Drives per Storage Array | Maximum Volumes per Storage Array* |
|---|-----------------|---|----------------------------------|------------------------------------|
| AM1932 | 1932 | 9.70, 10.30, 10.35, 10.36, 10.50, 10.60 | 48 | 256 |
| CDE3994 | 3992 or 3994 | 9.16, 9.19, 9.23, 9.60, 10.10, 10.15, 10.36, 10.50, 10.60 | 112 | 1024 |
| CDE4900 | 4900 | 10.50, 10.60, 10.75 | 112 | 1024 |
| CDE2600 | 2600 | 10.70, 10.75 | 96 | 512 |
| Controller trays | | | | |
| SYM1200 | 4774 | 8.30 | 224 | 512 |
| FC1250 | 4884 | 8.30, 8.40, 9.10, 9.12 | 224 | 2048 |
| FC1275 | 5884 | 8.30, 8.40, 8.41, 9.10, 9.12, 9.19, 9.23, 10.10 | 224 | 2048 |
| SAT2600 | 2882-SATA | 8.41 | 112 | 1024 |
| CE6998 | 6091 | 9.14, 9.16, 9.19, 9.23, 9.60, 10.10, 10.15, 10.36, 10.50, 10.60 | 224 | 2048 |
| CE7900 | 7091 | 10.30, 10.36, 10.50, 10.60, 10.75 | 448*** | 2048 |
| CE7922 | 7091 | 10.60 | 448*** | 2048 |
| <p>* Snapshot repository volumes and Remote Volume Mirroring repository volumes are included in the number of volumes supported.</p> <p>** Additional drive trays are not supported.</p> <p>*** A maximum of 480 drives are supported with the DE6900 drive tray.</p> | | | | |

Supported Drive Trays

The drive tray is a unit that contains up to 60 drives, redundant cooling fans and power supplies, and one or two environmental services monitors (ESMs). Drive trays do not contain controllers.

Supported Drive Trays

| Drive Tray | Version of the Storage Management Software | Drives per Tray | Drive Technology |
|---------------|--|-----------------|----------------------|
| SYM2200 | 8.30 | 10 | 1-Gb/s Fibre Channel |
| FC2500 | 8.30 | 14 | 1-Gb/s Fibre Channel |
| FC2600 (JBOD) | 8.30, 8.33, 8.40, 9.10, 9.12, 9.14, 9.16, 9.23, 10.10, 10.15, 10.36, 10.60 | 14 | 2-Gb/s Fibre Channel |
| FC2610 (SBOD) | 9.10, 9.12, 9.14, 9.16, 9.19, 9.23, 10.10, 10.15, 10.36, 10.60 | 14 | 2-Gb/s Fibre Channel |
| AT2655 | 8.41, 8.42, 9.10, 9.12, 9.14, 9.19, 9.23, 10.10, 10.15, 10.60 | 14 | 2-Gb/s SATA |
| DM1300 | 9.17, 9.50, 9.70, 10.35, 10.60 | 12 | 3-Gb/s SAS and SATA |
| FC4600 (SBOD) | 9.16, 9.19, 9.23, 9.60, 10.10, 10.15, 10.30, 10.36, 10.50, 10.60, 10.75 | 16 | 4-Gb/s Fibre Channel |
| DE6900 | 10.60, 10.75 | 60 | 4-Gb/s Fibre Channel |
| DE1600 | 10.70, 10.75 | 12 | 6-Gb/s SAS |
| DE5600 | 10.70, 10.75 | 24 | 6-Gb/s SAS |

Software Compatibility for Controller-Drive Trays and Controller Trays

The following table shows the relationship between controller-drive trays, controller trays, and the versions of the storage management software that are supported by each tray. The table also lists the drive trays that are supported by controller-drive trays or controller trays.

Software Compatibility for Controller-Drive Trays and Controller Trays

| Tray | Version | SYM2200 Drive Tray | FC2500 Drive Tray | FC2600 Drive Tray | AT2655 Drive Tray | FC2610 Drive Tray | FC4600 Drive Tray | DE6900 Drive Tray | DM1300 Drive Tray | DE1600 Drive Tray | DE5600 Drive Tray |
|--|---------|--------------------|-------------------|-------------------|-------------------|-------------------|-------------------|-------------------|-------------------|-------------------|-------------------|
| SHV2200 or SHV2500 controller-drive tray | 8.30 | X | X | X | | | | | | | |

| Tray | Version | SYM2200 Drive Tray | FC2500 Drive Tray | FC2600 Drive Tray | AT2655 Drive Tray | FC2610 Drive Tray | FC4600 Drive Tray | DE6900 Drive Tray | DM1300 Drive Tray | DE1600 Drive Tray | DE5600 Drive Tray |
|--|---------|---|-------------------------|-------------------------|-------------------------|-------------------------|-------------------------|-------------------------|-------------------------|-------------------------|-------------------------|
| SHV2520 (dual) controller- drive tray | 8.33 | Additional drive trays are not supported. | | | | | | | | | |
| | 8.40 | | | | | | | | | | |
| | 9.10 | | | | | | | | | | |
| | 9.12 | | | | | | | | | | |
| | 9.19 | | | | | | | | | | |
| | 9.23 | | | | | | | | | | |
| | 10.10 | | | | | | | | | | |
| SHV2600 controller- drive tray | 8.33 | | | X | | | | | | | |
| | 8.40 | | | X | | | | | | | |
| | 9.10 | | | X | | X | | | | | |
| | 9.12 | | | X | | X | | | | | |
| | 9.19 | | | X | X | X | X | | | | |
| | 9.23 | | | X | X | X | X | | | | |
| | 10.10 | | | X | X | X | X | | | | |
| SAT2700 controller- drive tray | 8.42 | Additional drive trays are not supported. | | | | | | | | | |
| | 9.12 | | | | | | | | | | |
| SAT2800 controller- drive tray | 8.42 | | | | X | | | | | | |
| | 9.12 | | | X | X | X | | | | | |
| AM1331 and AM1333 controller- drive trays | 9.23 | | | | | | | | X | | |
| | 9.30 | | | | | | | | X | | |
| | 9.60 | | | | | | | | X | | |
| | 9.70 | | | | | | | | X | | |
| | 10.30 | | | | | | | | X | | |
| | 10.35 | | | | | | | | X | | |

| Tray | Version | SYM2200 Drive Tray | FC2500 Drive Tray | FC2600 Drive Tray | AT2655 Drive Tray | FC2610 Drive Tray | FC4600 Drive Tray | DE6900 Drive Tray | DM1300 Drive Tray | DE1600 Drive Tray | DE5600 Drive Tray |
|---|---------|--------------------------|-------------------------|-------------------------|-------------------------|-------------------------|-------------------------|-------------------------|-------------------------|-------------------------|-------------------------|
| | 10.36 | | | | | | | | X | | |
| | 10.50 | | | | | | | | X | | |
| | 10.60 | | | | | | | | X | | |
| AM1532 controller- drive tray | 9.70 | | | | | | | | X | | |
| | 10.30 | | | | | | | | X | | |
| | 10.35 | | | | | | | | X | | |
| | 10.36 | | | | | | | | X | | |
| | 10.50 | | | | | | | | X | | |
| | 10.60 | | | | | | | | X | | |
| AM1932 controller- drive tray | 9.70 | | | | | | | | X | | |
| | 10.30 | | | | | | | | X | | |
| | 10.35 | | | | | | | | X | | |
| | 10.36 | | | | | | | | X | | |
| | 10.50 | | | | | | | | X | | |
| | 10.60 | | | | | | | | X | | |
| CDE3994 controller- drive tray | 9.16 | | | X | X | X | X | | | | |
| | 9.19 | | | X | X | X | X | | | | |
| | 9.23 | | | X | X | X | X | | | | |
| | 9.60 | | | X | X | X | X | | | | |
| | 10.10 | | | X | X | X | X | | | | |
| | 10.15 | | | X | X | X | X | | | | |
| | 10.36 | | | X | X | X | X | | | | |
| | 10.50 | | | | | X | X | | | | |
| | 10.60 | | | X | X | X | X | X | | | |

| Tray | Version | SYM2200 Drive Tray | FC2500 Drive Tray | FC2600 Drive Tray | AT2655 Drive Tray | FC2610 Drive Tray | FC4600 Drive Tray | DE6900 Drive Tray | DM1300 Drive Tray | DE1600 Drive Tray | DE5600 Drive Tray |
|---|---------|--------------------------|-------------------------|-------------------------|-------------------------|-------------------------|-------------------------|-------------------------|-------------------------|-------------------------|-------------------------|
| CDE4900 controller- drive tray | 10.60 | | | | | | X | | | | |
| | 10.75 | | | | | | X | | | | |
| CDE2600 controller- drive tray | 10.70 | | | | | | | | | X | X |
| | 10.75 | | | | | | | | | X | X |
| SAT2600 controller tray | 8.41 | | | X | | | | | | | |
| SYM1200 controller tray | 8.30 | X | X | X | | | | | | | |
| FC1250 controller tray | 8.30 | X | X | X | | | | | | | |
| | 8.40 | X | X | X | | | | | | | |
| | 9.10 | | | X | X | X | | | | | |
| | 9.12 | X | X | X | X | X | | | | | |
| FC1275 controller tray | 8.30 | | | X | | | | | | | |
| | 8.40 | | | X | | | | | | | |
| | 8.41 | | | | X | | | | | | |
| | 9.10 | | | X | X | | | | | | |
| | 9.12 | | | X | X | X | | | | | |
| | 9.19 | | | X | X | X | X | | | | |
| | 9.23 | | | X | X | X | X | | | | |
| | 10.10 | | | X | X | X | X | | | | |
| CE6998 controller tray | 9.14 | | | X | X | X | | | | | |
| | 9.16 | | | X | X | X | X | | | | |
| | 9.19 | | | X | X | X | X | | | | |
| | 9.23 | | | X | X | X | X | | | | |

| Tray | Version | SYM2200 Drive Tray | FC2500 Drive Tray | FC2600 Drive Tray | AT2655 Drive Tray | FC2610 Drive Tray | FC4600 Drive Tray | DE6900 Drive Tray | DM1300 Drive Tray | DE1600 Drive Tray | DE5600 Drive Tray |
|------------------------------|---------|--------------------------|-------------------------|-------------------------|-------------------------|-------------------------|-------------------------|-------------------------|-------------------------|-------------------------|-------------------------|
| | 9.60 | | | X | X | X | X | | | | |
| | 10.10 | | | X | X | X | X | | | | |
| | 10.15 | | | X | X | X | X | | | | |
| | 10.36 | | | X | X | X | X | | | | |
| | 10.50 | | | X | X | X | X | | | | |
| | 10.60 | | | X | X | X | X | | | | |
| CE7900 controller tray | 10.30 | | | X | X | X | X | | | | |
| | 10.36 | | | X | X | X | X | | | | |
| | 10.50 | | | X | X | X | X | | | | |
| | 10.60 | | | X | X | X | X | X | | | |
| | 10.75 | | | X | X | X | X | X | | | |
| CE7922 controller tray | 10.60 | | | | | | X | X | | | |

HBAs and Driver Information



NOTE The SANtricity ES Storage Manager Installation DVD does not contain any drivers or configuration files for the host bus adapters (HBAs) that were tested with this version of the storage management software. Use the Internet download sites provided in this section to help you to find these files.

You can obtain information about supported HBAs from the Compatibility Matrix. To check for current compatibility, refer to the Compatibility Matrix at <http://www.lsi.com/compatibilitymatrix/>.

Driver Information

The Compatibility Matrix contains information about the files that are needed to support the HBAs. Use these Internet locations to obtain the drivers that are listed in the Compatibility Matrix.

| HBA Driver Vendor | Internet Location |
|-------------------|---|
| Emulex | http://www.emulex.com/downloads.html |
| JNI/AMCC | http://www.amcc.com/drivers/notice.html |
| LSI | http://www.lsi.com/cm/DownloadSearch.do |

| HBA Driver Vendor | Internet Location |
|--|---|
| IBM | http://www.ibm.com/support/us |
| QLogic* | http://www.qlogic.com/support/drivers_software.asp |
| Oracle (Sun) | http://www.oracle.com/technetwork/indexes/downloads/index.html |
| * URLs on the QLogic website are case sensitive. | |

Upgrading Trays in the Storage Array

To upgrade trays in the storage array, you can choose from these upgrade options:

- Upgrade one model of a controller-drive tray to another model of a controller-drive tray.
- Convert a controller-drive tray to a drive tray, and add a controller tray.
- Upgrade one model of a controller tray to another model of a controller tray.

Before you upgrade trays in your storage array, keep these guidelines in mind:

- Review “[Upgrading Options for the Supported Trays](#)” for a list of possible upgrade options.
- Become familiar with the new components that you are installing into the existing trays and the components that you are installing into an existing storage array. The tray connectors and switches might be arranged differently than those on the tray that you are removing. Refer to the conversion kit instructions for the tray that you want to upgrade.
- Make sure that the new tray is compatible with the existing trays. For example, some drive trays might not be supported with the new equipment. To check for compatibility, refer to the Compatibility Matrix at <http://www.lsi.com/compatibilitymatrix>.
- Make sure that the new firmware is compatible with the existing trays and the existing firmware.
- Make sure that you know of any cabling issues with the new trays. For a complete description of various cabling options, refer to the topics under *Hardware Cabling* or to the SANtricity ES Storage Manager Installation DVD for the corresponding PDF document.



ATTENTION Possible loss of data access – Before you start any upgrade procedure, back up your data to an external source.

Upgrading Options for the Supported Trays

Upgrading Options for Supported Trays

| Tray Name | Tray Upgrading Option |
|---|--|
| Upgrade a controller-drive tray to a different controller-drive tray | |
| SHV2520 controller-drive tray | Use volume group relocation to migrate the drives to the CDE3994 controller-drive tray |
| SHV2600 controller-drive tray | |
| SAT2700 controller-drive tray | |
| SAT2800 controller-drive tray | |
| Convert a controller-drive tray to a drive tray, and add a controller tray | |
| SHV2200 controller-drive tray | Convert to the FC2600 drive tray, and add the CE6998 controller tray or the CE7900 controller tray |

| Tray Name | Tray Upgrading Option |
|---|--|
| SHV2500 controller-drive tray | |
| SHV2520 controller-drive tray | |
| SHV2600 controller-drive tray | |
| SAT2600 controller-drive tray | Convert to the AT2655 drive tray, and add the CE6998 controller tray or the CE7900 controller tray |
| SAT2700 controller-drive tray | |
| SAT2800 controller-drive tray | |
| CDE3994 controller-drive tray | Convert to the FC4600 drive tray, and add the CE6998 controller tray or the CE7900 controller tray |
| Replace a controller tray with a different controller tray | |
| SYM1200 controller tray | Remove the SYM1200 controller tray, and add the CE6998 controller tray or the CE7900 controller tray |
| FC1250 controller tray | Remove the FC1250 controller tray, and add the CE6998 controller tray or the CE7900 controller tray |
| FC1275 controller tray | Remove the FC1275 controller tray, and add the CE6998 controller tray or the CE7900 controller tray |
| CE6998 controller tray | Remove the CE6998 controller tray, and add the CE7900 controller tray |

Upgrading the Controller-Drive Trays

If you want to upgrade from one model of controller-drive tray to the CDE3994 controller-drive tray, you can use the import and export functions of the SANtricity ES Storage Manager software.



NOTE The import and export functions are only available if your controllers are running controller firmware version 7.10 or later.

You will export the volume groups from the old controller-drive tray, and import those volume groups to the CDE3994 controller-drive tray. For more information, refer to the online help topics in SANtricity ES Storage Manager.

Converting a Controller-Drive Tray to a Drive Tray and Adding a Controller Tray

You can upgrade the storage array by converting the controller-drive tray to a drive tray and adding a controller tray. Contact your Customer and Technical Support representative to order a tray conversion kit. Refer to the tray conversion kit instructions for complete instructions about how to convert a controller-drive tray to a drive tray. Use this procedure to add a new controller tray to your storage array.



NOTE If you are adding a new controller tray that has controllers running controller firmware version 7.10 or later, the controllers in your original storage array must also be running controller firmware version 7.10 or later.

Also, make sure that you can connect the tray and the drives to the new controller. For example, you cannot connect a DM1300 drive tray to a CE6998 controller tray or a CE7900 controller tray.



NOTE Before starting this procedure, make sure that you have the removal and replacement procedure instructions for the environmental services monitors (ESMs). For older hardware models, this documentation is not included in documentation delivered with the current release of SANtricity ES Storage Manager.

1. Stop I/O, and turn off the power to the controller-drive tray and the drive trays.
2. Disconnect the host cables from the controllers.
3. If the storage array has drive trays connected to the controller-drive tray, disconnect the cables from the controllers to the ESMs in the drive trays.
4. Remove the controllers from the controller-drive tray.
5. Insert the ESMs into the controller-drive tray to replace the controllers.
6. Connect the cables from the ESMs in the other drive trays to the new ESMs.
 - If the drive cable is connected to port 1 of the drive tray, connect the other end of the cable to port 2 of the new ESM.
 - If the drive cable is connected to port 2 of the drive tray, connect the other end of the cable to port 1 of the new ESM.

For a complete description of the various cabling options, refer to the topics under *Hardware Cabling* or to the SANtricity ES Storage Manager Installation DVD for the corresponding PDF document.



NOTE Make sure that you have enough space in the cabinet for the new controller tray before you perform the next step.

7. Insert the new controller tray into the cabinet. Refer to the topics under *Installation* for the controller tray that you have chosen to upgrade for more details about how to secure the controller tray to the cabinet. The *Installation* topics are also available as PDF documents on the SANtricity ES Storage Manager Installation DVD.
8. Connect the host cables to the host ports on the controller tray.
9. Connect the cables from the controllers to the ESMs.
10. Update the labels on each cable that has changed its connections. The following table shows the information that is recommended on the label.

Label Information for Cables

| Type of Cable | Items to Label |
|---------------|--|
| Drive cable | Controller ID |
| | Drive channel number and port ID in the controller |
| | ESM ID |
| | ESM port ID |
| | Drive tray ID |
| Host cable | Host name |
| | HBA port |
| | Controller ID |
| | Host channel ID |

11. Connect the power cord or power cords to the new controller tray.
12. Turn on the power to the drive trays.

The drives might take several minutes to complete the power-on procedure.
13. Turn on the power to the new controller tray.
14. Use SANtricity ES Storage Manager to check that your configuration is correct.
15. Is your configuration correct?
 - **Yes** – Go to step 15.
 - **No** – If possible, correct your configuration. If the problem is not resolved, contact your Customer and Technical Support representative.
16. If you want to expand the storage array, you can now add drive trays. For a complete description of the various cabling options, refer to the topics under *Hardware Cabling* or to the SANtricity ES Storage Manager Installation DVD for the corresponding PDF document.

Replacing an Existing Controller Tray with a CE7900 Controller Tray

You can replace an existing controller tray with a CE7900 controller tray to improve the capability of your storage array. Use this procedure to replace your old controller tray with the CE7900 controller tray.

 **NOTE** Controllers in the controller tray that you are removing must be running controller firmware 7.10 or later. If not, you must update the controller firmware to 7.10 or later.

 **NOTE** If you are upgrading the controller tray to a CE7900 controller tray, you need additional vertical space in the cabinet. The CE7900 controller tray is a 4U-high tray, while the CDE3994 controller-drive tray is a 3U-high tray.

1. Turn off the power to the old controller tray, and disconnect the power cord.



NOTE Do not turn off the power to the drive trays that are connected to the old controller tray.

2. Disconnect all of the cables from the drive ports on the old controller tray.
3. Disconnect all of the cables from the host ports on the old controller tray.



WARNING (W08) Risk of bodily injury –



>18 kg (39.7 lbs)

Two persons are required to safely lift the component.

4. If the old controller tray has Ethernet cables for out-of-band management, disconnect those cables.
5. Slide the old controller tray out of the cabinet.
6. Slide the CE7900 controller tray into the empty spot in the cabinet, and secure it firmly.

For information about how to secure the CE7900 controller tray to the cabinet, refer to the topics under *CE7900 controller tray Installation* for the CE7900. A PDF version of the document is available on the SANtricity ES Storage Manager Installation DVD.



WARNING (W03) Risk of exposure to laser radiation – Do not disassemble or remove any part of a Small Form-factor Pluggable (SFP) transceiver because you might be exposed to laser radiation.



NOTE If you are using Fibre Channel cables, insert a Small Form-factor Pluggable (SFP) transceiver into the interface port on the controllers in the controller tray and the ESMs in the drive trays.

7. Connect the drive trays that were previously used with the old controller tray to the CE7900 controller tray.
8. Reattach the host cabling to the CE7900 controller tray.
9. Update the labels on each cable that has changed connections. The following table shows the information that is recommended on the label.

Label Information for Cables

| Type of Cable | Items to Label |
|---------------|--|
| Drive cable | Controller ID |
| | Drive channel number and port ID in the controller |
| | ESM ID |
| | ESM port ID |
| | Drive tray ID |
| Host cable | Host name |

| Type of Cable | Items to Label |
|---------------|-----------------|
| | HBA port |
| | Controller ID |
| | Host channel ID |

10. If the old controller tray has Ethernet cables for out-of-band management, reattach those cables.
11. Connect the power cord to the CE7900 controller tray, and turn on the power to the new controller tray.
The CE7900 controller tray starts to communicate with the drive trays. Front panel LEDs blink during this process.
12. Use SANtricity ES Storage Manager to add the CE7900 controller tray as a new storage array.
13. Launch the Array Management Window.
14. Make sure that all of the drive tray volume and mappings are still intact.
15. Does any component have a Needs Attention status?
 - **Yes** – Click the **Recovery Guru** toolbar button in the Array Management Window, and complete the recovery procedure. If the problem is not resolved, contact your Customer and Technical Support representative.
 - **No** – Go to step 16.
16. Create, save, and print a new storage array profile.

Upgrading the Firmware and the NVSRAM

You can upgrade the firmware of the controllers and the NVSRAM in the storage array by using the storage management software.

In the process of upgrading the firmware, the firmware file is downloaded from the host to the controller. After downloading the firmware file, you can upgrade the controllers in the storage array to the new firmware immediately. Optionally, you can download the firmware file to the controller and upgrade the firmware later at a more convenient time.

Activating the Firmware

The process of upgrading the firmware after downloading the firmware file is known as activation. During activation, the existing firmware file in the memory of the controller is replaced with the new firmware file.

You might want to activate the firmware or NVSRAM files at a later time because of the following reasons:

- **Time of day** – Activating the firmware and the NVSRAM can take a long time, so you might want to wait until I/O loads are lighter. The controllers will go offline briefly to load the new firmware.
- **Type of package** – You might want to test the new firmware on one storage array before upgrading the firmware in other storage arrays.

The firmware upgrade process requires that the controllers have enough free memory space in which the firmware file resides until activation.

Firmware Version

A version number exists for each firmware file. For example, 06.60.08.00 is a version number for a firmware file. The first two digits indicate the major revision of the firmware file. The remaining digits indicate the minor revision of the firmware file. You can view the version number of a firmware file in the Upgrade Controller Firmware window and the Download Firmware dialog.

The process of upgrading the firmware can be either a major upgrade or a minor upgrade depending on the version of the firmware.

For example, the process of upgrading the firmware is major if the version of the current firmware is 06.60.08.00, and you want to upgrade the firmware to version 07.36.12.00. In this example, the first two digits of the version numbers are different and indicate a major upgrade. In a minor upgrade, the first two digits of the version numbers are the same. For example, the process of upgrading the firmware is minor, if the version of the current firmware is 06.60.08.00, and you want to upgrade the firmware to version 06.60.18.00, or any other minor revision of the firmware.



IMPORTANT The firmware versions from 05.xx.xx.xx through 06.12.xx.xx are versions before the RAIDCore1. The firmware versions from 06.14.xx.xx through 06.60.xx.xx are RAIDCore1. The firmware version starting from 07.xx.xx.xx are RAIDCore2.

You can use the Enterprise Management Window to perform both major upgrades and minor upgrades.

You can use the Enterprise Management Window to perform a major upgrade from firmware version number 05.40.xx.xx to any later version, such as 06.xx.xx.xx, and 07.xx.xx.xx, where xx represent the digits that indicate the minor revision of the firmware.

You can use the Array Management Window to perform minor upgrades only.

The storage management software checks for existing conditions in the storage array before upgrading the firmware. Any of these conditions in the storage array can prevent the firmware upgrade:

- An unsupported controller type or controllers of different types that are in the storage array and cannot be upgraded
- One or more failed drives
- One or more hot spare drives that are in use
- Two or more volume groups that are incomplete
- Operations, such as defragmenting a volume group, downloading of drive firmware, and others that are in progress
- Missing volumes that are in the storage array
- Controllers that have a status other than Optimal
- The storage partitioning database is corrupt
- A data validation error occurred in the storage array
- The storage array is in the Needs Attention status
- The storage array is unresponsive, and the storage management software cannot communicate with the storage array
- The Event Log entries are not cleared

For more information on downloading the firmware and NVSRAM, refer to the online help topics in SANtricity ES Storage Manager.

You can correct some of these conditions by using the Array Management Window. However, for some of the conditions, you might need to contact your Customer and Technical Support representative. The storage management software saves the information about the firmware upgrade process in log files. This action helps the Customer and Technical Support representative to understand the conditions that prevented the firmware upgrade.

You also can use the command line interface (CLI) to download and activate firmware to several storage arrays. For more information, refer to the online help topics in SANtricity ES Storage Manager.

Upgrading from Limited High Availability (LHA) to Full High Availability (FHA)

You can upgrade the environmental services monitors (ESMs) in the drive trays from LHA ESMs to FHA ESMs by using SANtricity ES Storage Manager. The following sections describe the procedure for upgrading from an LHA ESM to an FHA ESM.

Terms Applicable to LHA and FHA

Terms Applicable to LHA and FHA

| Term | Definition | | |
|------------|--|--|--|
| LHA | Limited high availability, also known as dSATA Phase 1. This specification refers to each ESM that retains sole ownership of seven drives per drive tray, without full failover capacity. | | |
| FHA | Full high availability, also known as dSATA Phase 2. This specification refers to each ESM that retains ownership of seven drives per drive tray. The first version of FHA consists of firmware version level 9550 and controller firmware level 05.41.50.xx. Anything prior to this version is LHA. | | |
| File types | *.dl | A download file in package format for the ESM. This file contains header information and package information. This file can contain more than one type of firmware packaged to download together. This file is downloadable through the storage management software. This file is not downloadable serially. | |
| | *.s3r | A raw "S" record file without header information and wrapper information that is not downloadable through the storage management software. | |
| | *.dlf | A raw firmware file without header information and wrapper information that is not downloadable through the storage management software. The *.dlf file is packaged into a *.dl file, and the *.dlf file is downloadable serially. | |
| | *.dlp | A download file in package format for the controller firmware. This file contains header information and package information, and it is downloadable through the storage management software. | |
| | Controller firmware | Controller firmware for the controllers in the storage array. The firmware is downloadable through the storage management software. | |
| | ESM firmware | Environmental services monitor (ESM) firmware for the drive tray: | |

| Term | Definition | |
|--|---|---|
| | | <ul style="list-style-type: none"> ▪ esm9566.d1 (DSATA) ▪ esm9728.d1 (ISATA) <p>The firmware is downloadable through the storage management software.</p> |
| | Customer-specific behavior (CSB) file | The CSB file (csb_xxx_xxxx.d11).* The file is downloadable through the storage management software. |
| noReboot | ESM firmware downgrade from FHA to LHA versions is wrapped in this format (esm95xx_noReboot.d1). After the firmware completes its download, it does not reboot the ESM to start running on the newly downloaded firmware code. In this case, you must manually reboot the ESM by cycling the power. | |
| * The xxx noted in the CSB file name indicates an OEM-specific identifier. | | |



ATTENTION Possible loss of data access – Downloading a customer-specific behavior (CSB) file with a non-matching shared secret results in the loss of data on the drive.

Upgrading an LHA ESM to an FHA ESM

Use this procedure to check the current firmware versions and to download the ESM firmware, the full high availability customer-specific behavior (FHA CSB) file, and the controller firmware. This procedure describes the LHA-to-FHA upgrade only. Perform this procedure only if your controller firmware version is 05.41.12.00 or earlier.

FHA controller firmware versions have implemented a “lockout” mechanism to prohibit downloading firmware to drive trays that contain LHA ESMs. This mechanism was implemented because the LHA controller firmware stops all I/O, which includes background DACstore and data scrubbing I/O, during an ESM download.

With FHA controller firmware, the I/O is no longer stopped during an ESM download, because the ESM can fail over the I/O to the other ESM. The lockout mechanism prevents users from starting a download to an LHA ESM, which cannot perform a failover.

Before you begin this procedure, verify these items:

- Make sure that your hardware is compatible with the software levels and the firmware levels to which you want to upgrade. Check the supported host bus adapters (HBAs), switches, tested driver levels, tested firmware levels, and specific hardware restrictions.
- Make sure that SANtricity ES Storage Manager Version 10.75 is installed and operating on your storage array.



NOTE Perform the steps of the procedure in order so that you download all FHA CSB and ESM firmware packages before you upgrade the FHA controller firmware.



ATTENTION Possible I/O failure and loss of data – Before you start the download process, suspend all I/O activity. If you do not suspend all I/O activity, I/O failure, data loss, and other serious problems could result.

1. Stop all I/O activity and background operations. You must stop the controller before downloading the firmware.
2. Check the current firmware levels from the storage array profile. Make sure that the controller firmware version is 05.41.12.00 or earlier.
 - a. In the Array Management Window, select **Storage Array >> View >> Profile**.
The **Storage Array Profile** window appears.
 - b. To view the current firmware and NVSRAM versions, click the **Controllers** tab in the **Storage Array Profile** window.
 - c. To save and print the configuration file, select **Storage Array >> Configuration >> Save**.
3. Do all of the managed devices in the storage array have an Optimal status?
 - **Yes** – Go to step 4.
 - **No** – Contact your Customer and Technical Support representative and work with this person to resolve all issues related to any device with a Needs Attention status or a Failed status. When all devices have an Optimal status, go to step 4.
4. Download the FHA ESM firmware package (`esm955xx.d1`) to all of the drive trays using the SANtricity ES Storage Manager software.
 - a. Select **Advanced >> Maintenance >> Download >> ESM Firmware**.
The **Download Environmental (ESM) Card Firmware** window appears.
 - b. Perform one of these actions:
 - **To select the existing environmental (ESM) card firmware** – Click **Select All**.
 - **To locate new firmware** – Click **Select File**.
 - c. To view the ESM files, select **All Files (*.*)** in the **Files of type** drop-down list.
 - d. Select the `esm955x.d1` file, and click **OK**.
The **ESM Firmware Compatibility Warning** dialog might appear if the ESM file does not pass the naming validation filter (for client versions prior to 08.41.xx.02).
 - e. Click **OK**.
The **Confirm Download** dialog appears.
 - f. To confirm the download, type `yes` in the space provided, and click **OK**.
5. Download the FHA CSB firmware package (`esm9549_csb_xxx_0410.d1`) to all of the drive trays using the SANtricity ES Storage Manager software.



NOTE The procedure to download the FHA CSB firmware package is the same as downloading FHA ESM firmware packages.

6. To make sure that the ESMs are at the correct firmware level, select **Advanced >> Maintenance >> Download >> ESM Firmware** in the Array Management Window.

The **Download Environmental (ESM) Card Firmware** window appears.

7. Start the download process for the most recent FHA and LHA firmware packages using the SANtricity ES Storage Manager software.
8. Download the controller firmware that corresponds to the controller that you want to upgrade. For more information about downloading the controller firmware, refer to the online help topics in SANtricity ES Storage Manager.

Required Computing Environment

The following sections describe the operating systems and system requirements for SANtricity ES Storage Manager.

Supported Operating Systems for SANtricity ES Storage Manager

The following table lists the operating systems that have been tested for compatibility with all functions of SANtricity ES Storage Manager Version 10.75.

Review the specifications for your operating system to make sure that your system meets the minimum requirements. The versions listed in the table were current at the time of release, but it is possible that more recent versions of the operating systems have been added since that time.

To check for current compatibility, refer to the Compatibility Matrix at <http://www.lsi.com/compatibilitymatrix>.

Supported Operating Systems for SANtricity ES Storage Manager

| Operating System and Edition | Version |
|---|--|
| Windows Server 2003 (Standard Server Edition and Enterprise Server Edition) | SP 2, R2 |
| Windows Server 2008 | SP 2, R2, Hyper-V |
| Solaris | 10 (SPARC) Update 8 10 x86 Update 8 |
| HP-UX (For hosts with Fibre Channel connections only) | 11.31 (PA-RISC and IA64) |
| AIX (For hosts with Fibre Channel connections only) | 5.3 TL12 6.1 TL6 7.1 |
| Red Hat Enterprise Linux | 5.5 |
| SUSE Linux Enterprise Server | 10, SP 3 11, SP1 |
| VMware | 3.5 U4 +P20 4.1 |

Supported Operating Systems for the Storage Management Station Only

The following table lists the operating systems that support the client-only version of SANtricity ES Storage Manager Version 10.75 (for storage management stations), but do not support the full version of SANtricity ES Storage Manager.

Supported Operating Systems for the Storage Management Station Only

| Operating System | Version or Edition |
|-------------------------------------|----------------------------------|
| Windows XP | Professional, SP 3 or later |
| Windows 7 | |
| Windows Vista | SP 1 |
| Red Hat Enterprise Linux | RH5 client |
| SUSE Linux Enterprise Server (SLES) | SLES 10 client SLES 11 client |

Failover Protection Using Multi-Path Drivers

The SANtricity ES Storage Manager software supports several types of failover protection that use multi-path drivers. The following table shows an overview of the default failover drivers and settings that can be used with SANtricity ES Storage Manager Version 10.75.

For information about multi-path drivers and how to install them, refer to the topics under *SANtricity ES Storage Manager Failover Drivers for Version 10.75* or the corresponding PDF document on the SANtricity ES Storage Manager Installation DVD.

Default Failover Settings by Operating System

| Operating System | Multi-Path Driver | Default Failover Setting | |
|---|---|--|--------------------------|
| All | | Auto-Volume Transfer (AVT) default condition | AVT requires mode select |
| Windows Server 2003 and Windows Server 2008 | Microsoft MPIO/DSM | Disabled by default | |
| Solaris* | Solaris MPxIO | Disabled by default | |
| HP-UX | HP Native MP using TPGS | Enabled by default | |
| VMware | VMware native failover driver | Disabled by default | |
| Linux | SANtricity ES Storage Manager Redundant Dual Active Controller (RDAC/MPP), DMPP | Disabled by default | |
| * The default failover settings for MPxIO vary between versions of the Solaris OS. RDAC is not supported on the Solaris 10 (SPARC) OS or the Solaris 10 x86 OS. | | | |

Java Runtime Environment

If you chose to install the SMruntime package, the Java runtime environment (JRE) files are installed. The folder where the files are installed varies according to the operating system. All operating systems require version 1.6.x of the JRE.

System Requirements for the HP-UX Operating System

Review these specifications to make sure that your system meets the minimum installation requirements.

An HP 9000 series server with the following components is required:

- A 180-MHz or faster microprocessor
- A minimum of 128 MB of random access memory (RAM) (256 MB or more preferred)
- A minimum of 175 MB of disk space must be available on the `/opt` directory
- An Ethernet network interface card
- A DVD-ROM drive
- A mouse or similar pointing device

Make sure that the storage management station is running the HP-UX version 11.31.

The SANtricity ES Storage Manager software installation program does not verify the updates. Some updates might be superseded by other updates. For information about the latest updates, refer to <http://www11.itrc.hp.com/service/home/home.do>.

Make sure that the maximum kernel parameters are configured depending on the requirements shown in the following table.

HP-UX Storage Management Station – Kernel Configuration Requirements

| Parameter | Description | Configuration |
|---------------------------------|-----------------------------|----------------|
| <code>max_thread_proc 64</code> | Maximum threads per process | 1024 |
| <code>maxfiles</code> | Soft file limit per process | 2048 |
| <code>maxuser</code> | Influences other parameters | 256 or greater |
| <code>nccallout</code> | Number of pending timeouts | 4144 |

System Requirements for the AIX Operating System

Review these specifications to make sure that your system meets the minimum general requirements.

An IBM RISC System/6000 system with the following components is required:

- A 43P 375-MHz PowerPC processor (minimum)
- A minimum of 128 MB of random access memory (RAM) memory
- A minimum of 60 MB of disk space must be available on the `/usr` directory and the `/opt` directory

- An Ethernet network interface card (NIC)
- A DVD-ROM drive
- A mouse or similar pointing device
- A GXT110P or later peripheral component interconnect (PCI) video card

For host systems, the following updates are required:

- A minimum of F50 (330-MHz 604e3 processor)
- A Symmetrical Multi-Processing (SMP) system with two or more processors supported

Make sure that the AIX 5.3 TL12, AIX 6.1 TL6, or AIX 7.1 operating system is running.

For AIX version 5.3, the Java runtime environment of the operating system requires the following base level file sets, or later, for all locales:

- `x11.adt.lib 5.3`
- `x11.adt.motif 5.3`
- `bos.adt.include 5.3`
- `bos.adt.prof 5.3`
- `bos.rte.libc 5.3`

To check the current level of `bos.rte.libc`, type this command, and press **Enter**:

```
lslpp -ah bos.rte.libc
```

System Requirements for the Solaris Operating System

Review these specifications to make sure that your system meets the minimum general requirements.

A Solaris 10 SPARC-based system or a Solaris 10 x86 system with these components is required:

- An S20 processor (minimum)
- A minimum of 256 MB of random access memory (RAM)
- A minimum of 66 MB of disk space must be available on the `/opt` directory with sufficient space for temporary installation files
- An Ethernet network interface card (NIC)
- A DVD-ROM drive
- A mouse or similar pointing device

Make sure that the system is running Solaris 10 Update 8 operating system.

System Requirements for the Linux Operating System

Review these specifications to make sure that your system meets the minimum general requirements.



NOTE The type of processor in your system determines whether you install the 32-bit package or the 64-bit package.

A system with the following components is required:

- An Intel 32-bit or 64-bit processor (excluding Itanium processors), or an Advanced Micro Devices (AMD) Opteron 32-bit or 64-bit processor
- A minimum of 256 MB of random access memory (RAM)
- A minimum of 180 MB of disk space must be available on the `/opt` directory with sufficient space for temporary installation files
- An Ethernet network interface card (NIC)
- A DVD-ROM drive
- A mouse or similar pointing device
- An advanced graphics port (AGP) video card (preferred) or a peripheral component interconnect (PCI) video card (to run the storage management software)

Use these minimum recommendations for the optional use of laptop computers as storage management stations:

- A Pentium II CPU (350 MHz or faster)
- A Celeron CPU (366 MHz or faster)
- An AMD-K6-2 CPU (400 MHz or faster)
- An AMD-K6-III (250 MHz or faster)

Make sure that the system is running with the appropriate Linux kernel: Red Hat Enterprise Linux 5.5 or higher, SUSE Linux V10 SP3, or SUSE Linux V11 SP1.

System Requirements for the Windows Operating System

These sections describe the requirements for the following Windows operating systems:

- Windows Server 2003
- Windows XP
- Windows Vista
- Windows 7
- Windows Server 2008
- Hyper-V

System Requirements for the Windows Server 2003 Operating System

Review these specifications to make sure that your system meets the minimum general requirements.

An x86-based system with these components is required:

- A Pentium or greater CPU, or equivalent (233 MHz or faster)
- A minimum of 128 MB of system memory (256 MB is recommended)
- One of the following disk space requirements:
 - For 32-bit systems, 120 MB of disk space must be available, with sufficient space for temporary installation files

- For 64-bit systems, 135 MB of disk space must be available, with sufficient space for temporary installation files



NOTE Typically, the `Common Files` directory is in the boot drive under the `Program Files` directory. Although you can choose where to put the SMclient software, the Java runtime environment (JRE) for the software is automatically installed in the `Common Files` directory.

- Administrator or equivalent permission
- An Ethernet network interface card (NIC)
- A DVD-ROM drive
- A mouse or similar pointing device
- An advanced graphics port (AGP) video card (preferred) or a peripheral component interconnect (PCI) video card



NOTE Many dedicated servers are not designed to run graphic-intensive software. If your system has video problems while running the storage management software, you might need to upgrade the server video card.

Computers that use system memory for video memory are not recommended for use with the storage management software.

For host systems, the following updates are required:

- A minimum of 70 MB of available disk space, which includes at least 40 MB of disk space on the drive on which the `Common Files` directory resides
- For 64-bit systems, a Xeon EM64T processor or an AMD Opteron 64 processor, minimum

Make sure that the systems are running the Windows Server 2003 Standard Server Edition or Enterprise Server Edition (32-bit or 64-bit) Service Pack 2, R2.

Use these minimum recommendations for the optional use of laptop computers as storage management stations:

- A Pentium II CPU, a Pentium III CPU, or a Pentium 4 CPU (350 MHz or faster)
- A Celeron CPU (366 MHz or faster)
- An AMD K6-2 CPU, an AMD K6-III CPU, an AMD Duron CPU, or an AMD Athlon CPU (400 MHz or faster)

System Requirements for the Windows XP Operating System

Review these specifications to make sure that your system meets the minimum general requirements.

An x86-based system with these components is required:

- A Pentium CPU or a Pentium-equivalent CPU (233 MHz or faster)
- A minimum of 64 MB of system memory (128 MB is recommended)
- A minimum of 1.5 GB of disk space must be available, with sufficient space for temporary installation files
- Administrator or equivalent privileges
- An Ethernet network interface card (NIC)

- A DVD-ROM drive
- A mouse or similar pointing device
- An advanced graphics port (AGP) video card (preferred) or a peripheral component interconnect (PCI) video card



NOTE Many dedicated servers are not designed to run graphic-intensive software. If your system has video problems while running the storage management software, you might need to upgrade the server video card.

Computers that use system memory for video memory are not recommended for use with the storage management software.

Make sure that the system is running the Windows XP Professional SP3 or the latest operating system.

Use these minimum recommendations for the optional use of laptop computers as storage management stations:

- A Pentium II CPU, a Pentium III CPU, or a Pentium 4 CPU (350 MHz or faster)
- A Celeron CPU (366 MHz or faster)
- An AMD K6-2 CPU, an AMD K6-III CPU, an AMD Duron CPU, or an AMD Athlon CPU (400 MHz or faster)

System Requirements for the Windows Server 2008 Operating System

Review these specifications to make sure that your system meets the minimum general requirements.

An x86-based system with the following components is required:

- A Pentium or greater CPU, or equivalent (1 GHz or faster, 2 GHz recommended)
- A minimum of 512 MB of system memory (1 GB is recommended)
- A minimum of 8 GB of disk space must be available, with sufficient space for temporary installation files (40 GB is recommended)



NOTE Typically, the `Common Files` directory is on the boot drive under the `Program Files` directory. Although you can choose where to put the SMclient software, the Java runtime environment (JRE) for the software is automatically installed in the `Common Files` directory.

- Administrator or equivalent permission
- An Ethernet network interface card (NIC)
- A DVD-ROM drive
- A mouse or similar pointing device
- An advanced graphics port (AGP) video card (preferred) or a peripheral component interconnect (PCI) video card



NOTE Many dedicated servers are not designed to run graphic-intensive software. If your system has video problems while running the storage management software, you might need to upgrade the server video card.

Computers that use system memory for video memory are not recommended for use with the storage management software.

For host systems, these updates are required:

- A minimum of 16 GB of available disk space, which includes at least 8 GB disk space on the drive on which the `Common Files` directory resides
- For 64-bit systems, a Xeon 64 CPU or greater (2 GHz minimum)

Make sure that the systems are running the Enterprise Edition or Standard Edition (32-bit or 64-bit) version of Windows Server 2008 SP 2 or Windows Server 2008 R2.

Use these minimum recommendations for the optional use of laptop computers as storage management stations:

- A Pentium 4 CPU (1 GHz or faster)
- A Celeron CPU (1 GHz or faster)
- An AMD K6-2 CPU, an AMD K6-III CPU, an AMD Duron CPU, or an AMD Athlon CPU (1 GHz or faster)

Server Virtualization with Hyper-V

Hyper-V implements server virtualization. Server virtualization enables you to run one or more virtual systems on a single server. Hyper-V is available a feature of the Windows Server 2008 operating system or as a stand-alone system.



NOTE The stand-alone version of Hyper-V requires a 64-bit (x64) server and either an AMD64 processor or an Intel IA-32e/EM64T (x64) processor with hardware-assisted virtualization support. Hyper-V does not support Itanium (IA64) processors.

For the virtual systems, Hyper-V supports the following 32-bit and 64-bit guest operating systems:

- Windows Server 2003 SP2
- Windows Server 2008 SP2
- SUSE Linux Enterprise Server Version 10.1
- SUSE Linux Enterprise Server Version 10.2

System Requirements for the Windows Vista and Windows 7 Operating Systems

Review these specifications to make sure that your system meets the minimum general requirements.

An x86-based system with these components is required:

- A Pentium CPU or a Pentium-equivalent CPU (1 GHz or faster)
- A minimum of 1 GB of system memory (2 GB is recommended)
- A minimum of 15 GB of disk space must be available, with sufficient space for temporary installation files
- Administrator or equivalent privileges
- An Ethernet network interface card (NIC)
- A DVD-ROM drive
- A mouse or similar pointing device
- An advanced graphics port (AGP) video card (preferred) or a peripheral component interconnect (PCI) video card



NOTE Many dedicated servers are not designed to run graphic-intensive software. If your system has video problems while running the storage management software, you might need to upgrade the server video card.

Computers that use system memory for video memory are not recommended for use with the storage management software.

Make sure that the system is running the Windows 7 operating system or the Windows Vista SP1 or later operating system.

Use these minimum recommendations for the optional use of laptop computers as storage management stations:

- A Pentium 4 CPU (1 GHz or faster)
- A Celeron CPU (1 GHz or faster)
- An AMD K6-2 CPU, an AMD K6-III CPU, an AMD Duron CPU, or an AMD Athlon CPU (1 GHz or faster)

System Requirements for the VMware Operating System

Review these specifications to make sure that your system meets the minimum general requirements.

A 64-bit x86-based system with the following components is required:

- A Xeon 64 or an AMD Opteron 64, or equivalent CPU (400 MHz or faster)
- A minimum of 128 MB of system memory (256 MB is recommended)
- An Ethernet network interface card (NIC)
- A DVD-ROM drive
- A mouse or similar pointing device
- An advanced graphics port (AGP) video card (preferred) or a peripheral component interconnect (PCI) video card

Make sure that the system is running VMware Version 3.5u5 +P20 or Version 4.1.

Boot Device Installation

The following sections describe how you can configure the storage array for boot device installation.

Boot Device Support

Not all operating systems support the use of a storage array as a boot device. The following table shows which operating systems support this configuration.

Operating System Support for Using a Storage Array as a Boot Device

| Operating System | Boot Device Support | Comments |
|--------------------------|---------------------|--|
| Windows Server 2003 | Yes | Where supported by the installed HBAs. |
| Windows XP | No | |
| Windows Vista, Windows 7 | No | |
| Windows Server 2008 | Yes | Where supported by the installed HBAs. |
| Solaris | Yes | |
| HP-UX | Yes | |
| AIX | No | |
| Linux | Yes | Where supported by the installed HBAs. |
| VMware | Yes | |

Installing the Boot Device

This section contains procedures to install a boot device in a storage array.

Before you install the storage management software components in the host, you must prepare the storage array and the host.

 **ATTENTION Possible loss of data access** – To make sure that you have failover protection, the storage array that you want to assign as a boot device must have dual controllers connected to two host bus adapters (HBAs). If the storage array has a single controller or dual controllers that are connected to the same HBA (host path), you do not have failover protection and could lose access to the boot device when the controller fails or has connection problems. For this reason, do not use this type of controller configuration with a boot device installation.

You must have administrator privileges to access the software. You must use the volume mapped to LUN 0 as the boot device. Some operating systems support booting only from LUN 0.

Before you proceed with the installation, make sure that you have installed SMclient from the SANtricity ES Storage Manager software in a host or a storage management station that is attached to the storage array.

 **IMPORTANT** Before you complete the installation of the storage management software components in the host, perform the tasks in this section to install and configure of the storage array and the host to use the storage array as a boot device. If you have questions or concerns about the installation procedures, contact your Customer and Technical Support representative.

 **IMPORTANT** On Itanium 64-bit hosts, the storage array can be successfully used as a boot device, but only when the original, local boot disk remains in the host system. Do not remove the local disk from the host system, or you will not be able to boot from the storage array.

Perform the following tasks in the order shown:

1. ["Starting the Client Software"](#)
2. ["Configuring the Boot Volume on the Storage Array"](#)
3. ["Configuring the Boot Volume on an Unconfigured Capacity Node"](#) or ["Configuring the Boot Volume on a Free Capacity Node,"](#) depending on your choices in ["Configuring the Boot Volume on the Storage Array"](#)
4. ["Ensuring a Single Path to the Storage Array"](#)
5. ["Preparing the Host"](#)
6. ["Completing the Installation Process"](#)

Starting the Client Software

1. Go to the storage management station on which you installed the client software.
2. Start the SANtricity ES Storage Manager software with the procedure for your operating system.
The Enterprise Management Window appears.
3. Select **Edit >> Add Storage Array**.
The **Add New Storage Array** dialog appears.
4. Add the Internet Protocol (IP) addresses or host names of the controllers in the storage array.
You must add the IP addresses or host names of the controllers one at a time. For more information, refer to the online help topics in the Enterprise Management Window.
The storage array that you plan to use as the boot device appears in the Enterprise Management Window.
5. Go to ["Configuring the Boot Volume on the Storage Array."](#)

Configuring the Boot Volume on the Storage Array

1. In the Enterprise Management Window, select the **Devices** tab.
2. Select the storage array.
3. Select **Tools >> Manage Storage Array**.
The Array Management Window for the selected storage array appears.
4. Select the **Logical** tab.
5. To determine where you can create a boot volume for the host, examine the Free Capacity nodes and Unconfigured Capacity nodes in the storage array.

Do you have 2 GB of capacity on either an Unconfigured Capacity node or a Free Capacity node?

- **Yes** – Go to step 11.
 - **No** – Go to step 6.
6. Determine how to create 2 GB of free capacity
- Do you have multiple Free Capacity nodes that might total more than 2 GB on a volume group, although no one node on that volume group is 2 GB or larger?
- **Yes** – Go to step 7.
 - **No** – Go to step 10.
7. Select the volume group that contains the Free Capacity nodes.
8. Select **Advanced >> Recovery >> Defragment Volume Group**.
- This operation consolidates all of the Free Capacity nodes in the volume group. For more information about defragmenting a volume group, refer to the online help topics in SANtricity ES Storage Manager.
9. Is the Free Capacity node that results from the procedure 2 GB or larger?
- **Yes** – Go to step 11.
 - **No** – Go to step 10.
10. Delete one or more volumes to create at least 2 GB of free capacity.
- For additional information about how to delete volumes, refer to the online help topics in the Array Management Window.
11. Decide which type of capacity you will use:
- You should now have 2 GB of capacity as an Unconfigured Capacity node or a Free Capacity node (or both).
- **Use the Unconfigured Capacity node** – Go to “[Configuring the Boot Volume on an Unconfigured Capacity Node](#).”
 - **Use the Free Capacity node** – Go to “[Configuring the Boot Volume on a Free Capacity Node](#).”

Configuring the Boot Volume on an Unconfigured Capacity Node

1. Right-click the Unconfigured Capacity node, and click **Create Volume**.
The **Volume Group Required** dialog appears.
2. Click **Yes**.
The **Create Volume Group Wizard - Introduction** dialog appears.
3. Click **Next**.
The **Create Volume Group Wizard - Volume Group Name & Drive Selection** dialog appears.
4. Type a name for the volume group in the **Volume group name** text box.
5. If you choose to create a secure volume group, select the **Create a secure volume group** check box.
The **Create a secure volume group** check box is active only when these conditions are met:
 - The SafeStore Drive Security premium feature is activated.
 - The security key is installed in the storage array.
 - At least one security capable drive is installed in the storage array.



ATTENTION Risk of data loss – After a volume group is secured, the only way to remove security is to delete the volume group. Deleting the volume group deletes all of the data in the volumes that comprise the volume group.

6. Select a method for defining which available drives to use in the volume group.



NOTE The Automatic method is the default selection. Only experts who understand drive configurations and optimal drive configurations should use the Manual method. It is recommended that you select the Automatic method.

7. Click **Next**.

The **Create Volume Group Wizard - RAID Level and Capacity** dialog appears if you selected the Automatic method. The **Create Volume Group Wizard - Manual Drive Selection** dialog appears if you selected the Manual method.

8. Specify the RAID level and capacity that you want for the volume group.

9. Click **Finish**.

The **Volume Group Created** dialog appears.

10. Click **OK**.

The **Create Volume Wizard - Introduction** dialog appears.

11. Click **Next**.

The **Create Volume Wizard - Specify Volume Capacity/Name** dialog appears.

12. Specify the boot volume capacity.

A capacity of 4 GB is recommended. The capacity must be at least 2 GB.

13. Name the volume to identify it as the boot volume.

14. Select **Customize settings** in the Advanced Volume Parameters area.

15. Click **Next**.

The **Create Volume Wizard - Specify Volume-to-LUN Mapping** dialog appears.

16. Select **Map later using the Mappings View** radio button.

17. To create the volume, click **Finish**.

The **Create Volume Wizard – Creation Successful** dialog appears.

18. Click **No**.

19. Click **OK**.

20. Use the Storage Partitioning premium feature to map the volume to the host that uses LUN 0.



NOTE For additional information about how to map volumes that use Storage Partitioning, refer to the online help topics in the Array Management Window.

21. Go to [“Ensuring a Single Path to the Storage Array.”](#)

Configuring the Boot Volume on a Free Capacity Node

1. Right-click the Free Capacity node that you want to use, and click **Create Volume**.

The **Create Volume Wizard - Introduction** dialog appears.

2. Click **Next**.

The **Create Volume Wizard - Specify Volume Capacity/Name** dialog appears.

3. Specify the boot volume capacity.

A capacity of 4 GB is recommended. The capacity must be at least 2 GB.

4. Name the volume to identify it as the boot volume.

5. Select **Customize settings** in the Advanced Volume Parameters area.

6. Click **Next**.

The **Create Volume Wizard - Specify Volume-to-LUN Mapping** dialog appears.

7. Select **Map later using the Mappings View** radio button.

8. To create the volume, click **Finish**.

The **Create Volume Wizard – Creation Successful** dialog appears with a prompt to configure another volume.

9. Click **No**.

10. Click **OK**.

11. Use the Storage Partitioning premium feature to map the volume to the host by using LUN 0.



NOTE For additional information about how to map volumes that use Storage Partitioning, refer to the online help topics in the Array Management Window.

12. Go to [“Ensuring a Single Path to the Storage Array.”](#)

Ensuring a Single Path to the Storage Array

After you have configured a boot volume, make sure that only one path to the storage array exists. The path must be configured to the controller that owns the boot volume (controller A).



NOTE If you removed a previously installed version of RDAC in a root-boot environment, you do not need to remove the installed version of RDAC again.

1. Choose one of two methods to make sure that the alternate path to the storage array is removed:

- **Method 1** – Remove the host interface cable to the alternate path. Go to step 3.
- **Method 2** – Modify NVSRAM to *temporarily* disable RDAC multi-path functionality in the storage array. Go to step 2.

2. Modify NVSRAM to *temporarily* disable RDAC multi-path functionality by performing these substeps:

- a. Select the storage array in the Enterprise Management Window.

- b. Select **Tools >> Execute Script**.

The **Script Editor** dialog appears.

- c. In the upper half of the **Script Editor** dialog, type these commands at the prompt, and press **Enter**.

```
set controller[a] HostNVSRAMByte[1,0x16]=0xFF,0x20;
```

```
set controller[b] HostNVSRAMByte[1,0x16]=0xFF,0x20;
```

- d. Select **Tools >> Execute Only**.

- e. For the NVSRAM modifications to take effect, turn off the power to the controller tray, wait 30 seconds for the controller tray to turn off the power, and turn on the power again.



ATTENTION Possible data corruption – Only one path to the storage array must exist when RDAC is removed. The path must be to the controller that owns the boot volume. If the host is permitted to start without RDAC and still has dual paths to the storage array, the data might become unusable.

3. Boot the host system.

4. Go to [“Preparing the Host.”](#)

Preparing the Host



ATTENTION Possible loss of access to the boot device and the operating system – After you install the boot device, do not delete the volume mapped to LUN 0 or reset the configuration. Performing these actions causes loss of access to the boot device and the operating system.

In this procedure, the default boot path refers to controller A, which owns the boot volume. The alternate boot path refers to controller B.

1. Enable the BIOS on the HBA that is connected to the default boot path.
For procedures about how to enable the HBA BIOS, refer to the host system documentation and the HBA documentation. After the BIOS is enabled, the host reboots automatically.
2. Make sure that the HBA with enabled BIOS is connected to the default boot path (controller A), and the HBA with disabled BIOS is connected to the alternate boot path (controller B).
3. Install the operating system on the host.
4. After the installation is complete, restart the operating system.
5. To enable the alternate path to the storage array, go to step 2 in [“Completing the Installation Process.”](#)

Completing the Installation Process

This procedure completes the root-boot environment setup. Use this procedure to restart the system or set the path for the command line interface (CLI), if necessary.

1. Do you want to install the software in a root-boot environment?
 - **Yes** – Go to step 2.
 - **No** – Go to step 5.
2. Based on the method that you used to disable the alternate path in step 1 in [“Ensuring a Single Path to the Storage Array,”](#) perform one of these actions to enable the alternate path to the storage array:
 - **You removed the host interface cable to the storage array** – Reattach the host interface cable to the alternate controller. Go to step 5.
 - **You modified NVSRAM to temporarily disable RDAC multi-path functionality in the storage array** – Go to step 3.
3. Will you download new controller firmware and NVSRAM to the storage array after the host software installation?
 - **Yes** – The new NVSRAM file is pre-configured to enable RDAC multi-path functionality. Go to step 5.
 - **No** – Go to step 4.
4. Open the command prompt window, and perform these substeps:
 - a. Type these commands, and press **Enter**.

```

"set controller[a] HostNVSRAMByte[1,0x16]=0xFF,0x20;"
"set controller[b] HostNVSRAMByte[1,0x16]=0xFF,0x20;"
          
```
 - b. For the NVSRAM modifications to take effect, turn off the power to the controllers, wait 30 seconds for the controllers to power down, and turn on the power.
5. Restart the host system.



IMPORTANT You can run the command line interface (CLI) from the installation target, or you can set the path to run the CLI from any location.

6. Do you want to set the path for the CLI?
 - **Yes** – Go to step 7.
 - **No** – Go to step 8.
7. To set the path for the CLI, perform these substeps:
 - a. Select **Start >> Settings >> Control Panel >> System**.
The **System Properties** dialog appears.
 - b. Select the **Advanced** tab.
 - c. Click **Environment Variables**.
 - d. Select the Path entry, and click **Edit** in the System variables area of the **Environment Variables** dialog.
 - e. In the **Variable Value** text box of the **Edit System Variable** dialog, type this command at the end of the current value, and press **Enter**. In this command, *<path>* is the path to the SMclient installation directory.

<path>

For example:

`%SystemRoot%\system32;%SystemRoot%;C:\ProgramFiles\StorageManager\client;`
 - f. Click **OK**. In the next dialog, click **OK**.
8. Based on your installation environment, perform one of these actions:
 - **You are using a cluster environment** – Go to step 9.
 - **You are using a standard environment** – Go to step 10.
9. Install the host software on each host in the server cluster.



IMPORTANT Do not configure the server cluster software at this time. You are instructed when to configure the server cluster software after you complete the storage management software installation.

You cannot mix two architectures in the same server cluster. For example, a server cluster cannot contain both the 32-bit version and the 64-bit version of the Windows OS.

10. Start the SANtricity ES Storage Manager software with the procedure for your operating system.
After the client software starts, the Enterprise Management Window appears.
Refer to the online help topics in SANtricity ES Storage Manager for more information about how to manage the storage array.

Failover Drivers

This topic describes how to use the failover drivers for the Windows operating system, the Linux operating system, and the Solaris operating system with SANtricity ES Storage Manager Version 10.80.

Overview of Failover Drivers

Failover drivers provide redundant path management for storage devices and cables in the data path from the host bus adapter to the controller. For example, you can connect two host bus adapters in the system to the redundant controller pair in a storage array, with different buses for each controller. If one host bus adapter, one bus cable, or one controller fails, the failover driver automatically reroutes input/output (I/O) to the good path, which permits the storage array to continue operating without interruption.

Failover drivers provide these functions:

- They automatically identify redundant I/O paths.
- They automatically reroute I/O to an alternate controller when a controller fails or all of the data paths to a controller fail.
- They check the state of known paths to the storage array.
- They provide status information on the controller and the bus.
- They check to see if the Service mode is enabled and if the modes have switched between Redundant Dual Active Controller (RDAC) and Auto-Volume Transfer (AVT).

Failover Driver Setup Considerations

Most storage arrays contain two controllers that are set up as redundant controllers. If one controller fails, the other controller in the pair takes over the functions of the failed controller, and the storage array continues to process data. You can then replace the failed controller and resume normal operation. You do not need to shut down the storage array to perform this task.

The redundant controller feature is managed by the failover driver software, which controls data flow to the controller pairs independent of the operating system (OS). This software tracks the current status of the connections and can perform the switch-over without any changes in the OS.

Whether your storage arrays have the redundant controller feature depends on a number of items:

- Whether the hardware supports it. Refer to the hardware documentation for your storage arrays to determine whether the hardware supports redundant controllers.
- Whether your OS supports certain failover drivers. Refer to the installation and support guide for your OS to determine if your OS supports redundant controllers.
- How the storage arrays are connected. The storage array must have two controllers installed in a redundant configuration. Redundant controllers can be configured only as an active/active pair. In an active/active pair, you can have multiple paths from the hosts to the active controller, and you perform load balancing on all of the active paths. Each controller has specific volumes assigned to it automatically. If one of the active controllers fails, the software automatically switches its assigned volumes to the other active controller.

Supported Failover Drivers Matrix

Matrix of Supported Failover Drivers by Operating System (OS)

| | Windows OS | Red Hat Enterprise Linux (RHEL) 5.5, 5.6., and 6.0 OSs and SUSE Linux Enterprise (SLES) 10.3, 10.4, 11.1 OSs | RHEL 6.0 OS and SUSE Linux Enterprise 11.1 OS | Solaris 10 OS |
|---|---|--|---|---------------|
| Failover driver type | MPIO | RDAC | DMMP | MPxIO |
| Storage array mode | Either Mode Select or AVT | Either Mode Select or AVT | Either Mode Select or AVT. However, AVT is not recommended. | Mode Select |
| Number of paths supported | 4 (default), 32 maximum | 4 (default), 32 maximum | 4 | 4 |
| Number of volumes supported | 255 | 255 | 255 | 255 |
| Failover through single host bus adapter (HBA) support?* | Yes, so long as at least one good path to each controller is detected | Yes, so long as at least one good path to each controller is detected | Yes, so long as at least one good path to each controller is detected | Yes |
| Cluster support? | Yes | Yes | Yes | Yes |
| * Using failover through a single HBA support is not recommended. | | | | |

Failover Configuration Diagrams

You can configure failover in several ways. Each configuration has its own advantages and disadvantages. This section describes these configurations:

- Single-host configuration
- Multi-host configuration

This section also describes how the storage management software supports redundant controllers.



NOTE For best results, use the multi-host configuration. It provides the fullest failover protection and functionality in the event that a problem exists with the connection.

Single-Host Configuration

In a single-host configuration, the host system contains two host bus adapters (HBAs), with each HBA connected to one of the controllers in the storage array. The storage management software is installed on the host. The two connections are required for maximum failover support for redundant controllers.

Although you can have a single controller in a storage array or a host that has only one HBA port, you do not have complete failover data path protection with either of those configurations. The cable and the HBA become a single point of failure, and any data path failure could result in unpredictable effects on the host system. For the greatest level of I/O protection, provide each controller in a storage array with its own connection to a separate HBA in the host system.

Single-Host-to-Storage Array Configuration

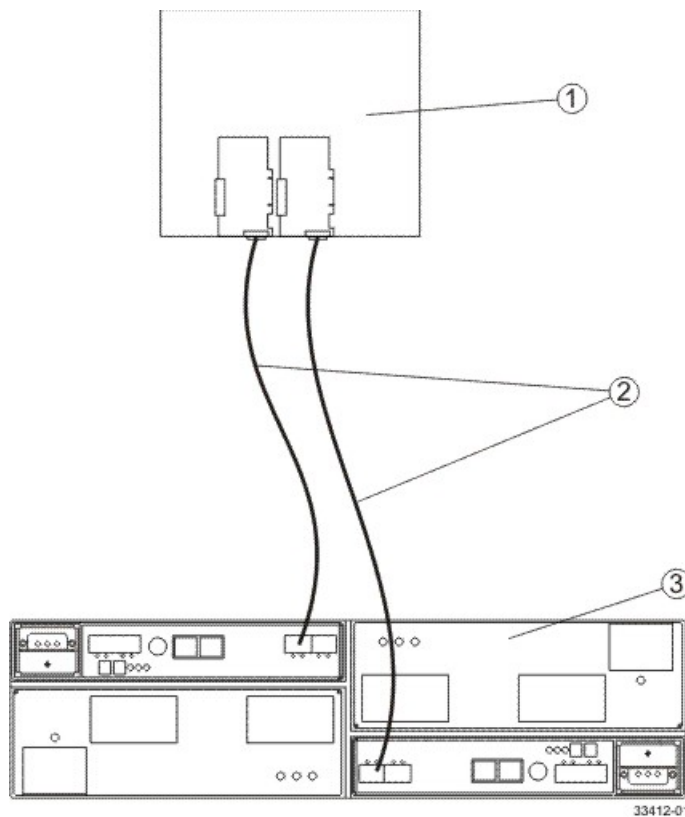

1. Host System with Two Fibre Channel Host Bus Adapters
2. Fibre Channel Connection – Fibre Channel Connection Might Contain One or More Switches
3. Storage Array with Two Fibre Channel Controllers

Multi-Host Configuration

For best results, use the multi-host configuration. It provides the best failover protection and functionality in the event that a problem exists with the connection.

In a multi-host configuration, two host systems are each connected by two connections to both of the controllers in a storage array. SANtricity ES Storage Manager, including failover driver support, is installed on each host.

Not every operating system supports this configuration. Consult the restrictions in the installation and support guide specific to your operating system for more information. Also, the host systems must be able to handle the multi-host configuration. Refer to the applicable hardware documentation.

Both hosts have complete visibility of both controllers, all data connections, and all configured volumes in a storage array, plus failover support for the redundant controllers. However, in this configuration, you must use caution when you perform storage management tasks (especially deleting and creating volumes) to make sure that the two hosts do not send conflicting commands to the controllers in the storage arrays.

These items are unique to this configuration:

- Both hosts must have the same operating system version and SANtricity ES Storage Manager version installed.

- Both host systems must have the same volumes-per-host bus adapter capacity. This capacity is important for failover situations so that each controller can take over for the other and show all of the configured volume groups and volumes.
- If the operating system on the host system can create reservations, the storage management software honors them. This concept means that each host could have reservations to specified volume groups and volumes, and only the software on that host can perform operations on the reserved volume group and volume. Without reservations, the software on either host system is able to start any operation. Therefore, you must use caution when you perform certain tasks that need exclusive access. Especially when you create and delete volumes, make sure that you have only one configuration session open at a time (from only one host), or the operations that you perform could fail.

Multi-Host-to-Storage Array Configuration

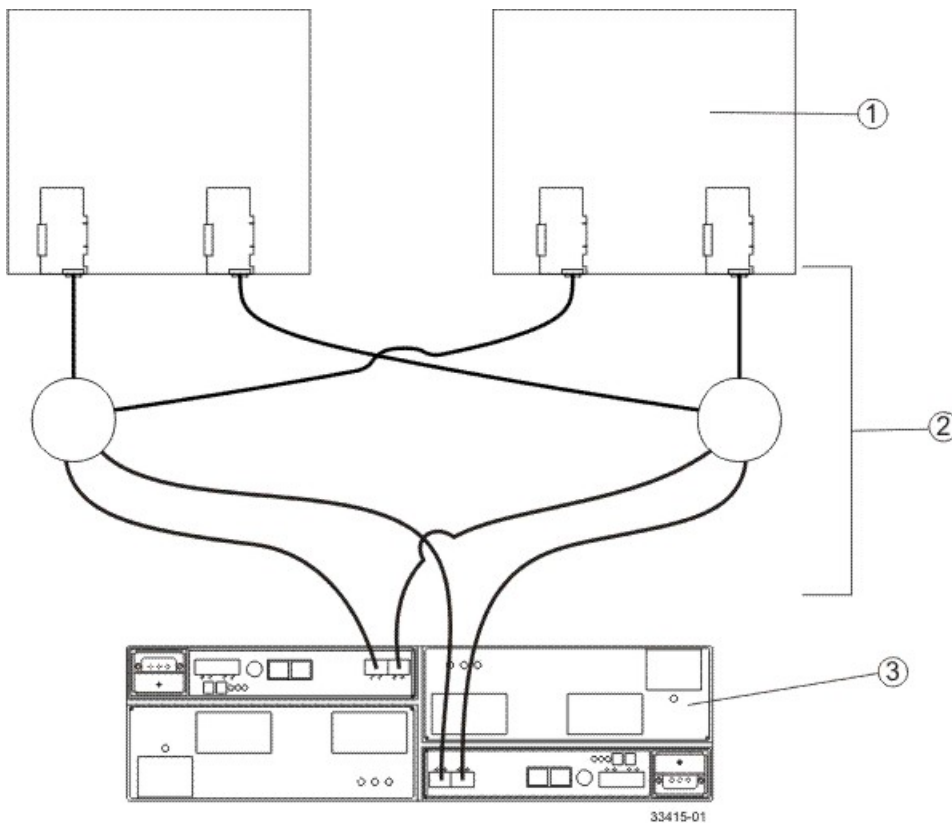

1. Two Host Systems, Each with Two Fibre Channel Host Bus Adapters
2. Fibre Channel Connections with Two Switches (Might Contain Different Switch Configurations)
3. Storage Array with Two Fibre Channel Controllers

Supporting Redundant Controllers

The following figure shows how failover drivers provide redundancy when the host application generates a request for I/O to controller A, but controller A fails. Use the numbered information to trace the I/O data path.

Example of Failover I/O Data Path Redundancy

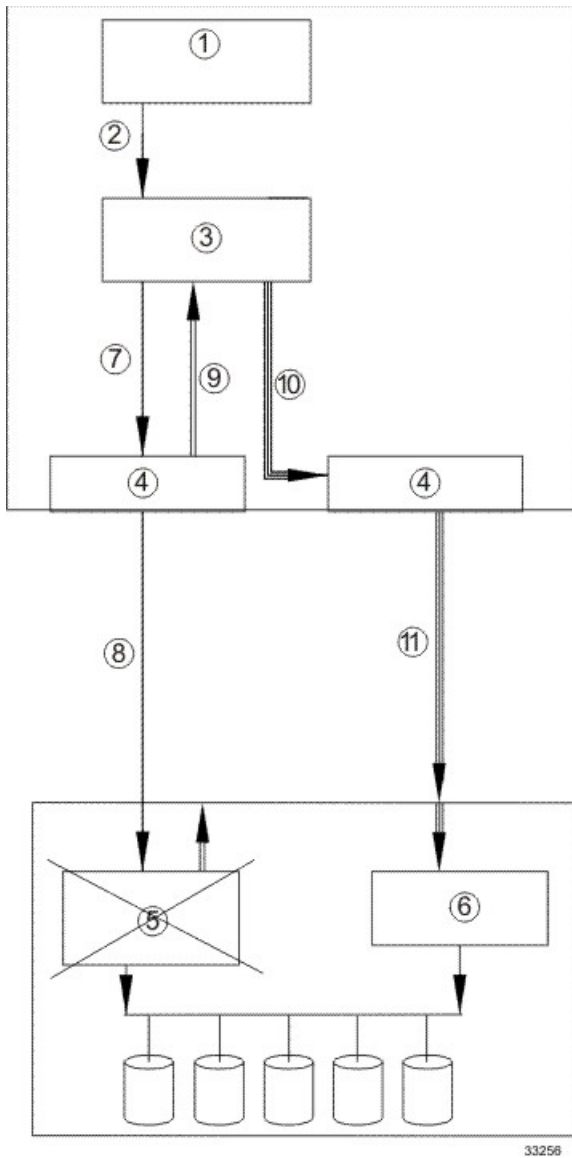

1. Host Application
2. I/O Request
3. Failover Driver
4. Host Bus Adapters
5. Controller A Failure
6. Controller B
7. Initial Request to the HBA
8. Initial Request to the Controller Failed
9. Request Returns to the Failover Driver
10. Failover Occurs and I/O Transfers to Another Controller
11. I/O Request Re-sent to Controller B

How a Failover Driver Responds to a Data Path Failure

One of the primary functions of the failover feature is to provide path management. Failover drivers monitor the data path for devices that are not working correctly or for multiple link errors. If a failover driver detects either of these conditions, the failover driver automatically performs these steps:

- The failover driver checks the pair table for the redundant controller.
- The failover driver forces volumes to the other controller and routes all I/O to the remaining active controller.
- The older version of RDAC notifies you that an error has occurred with the Service Action Required LEDs on the storage array and with a message that was sent to the error logs. The newer versions of RDAC and MPIO only send a message to the error logs.
- The failover driver performs a path failure if alternate paths to the same controller are available. If all of the paths to a controller fail, RDAC performs a controller failure.

A drive failure plus a controller failure are considered a double failure. The storage management software provides data integrity as long as all drive failures and controller failures are detected and fixed before more failures occur.

Responding to a Data Path Failure

Use the Major Event Log (MEL) to respond to a data path failure. The information in the MEL provides the answers to these questions:

- What is the source of the error?
- What is required to fix the error, such as replacement parts or diagnostics?

The next step depends on whether you are a system administrator or a Customer and Technical Support representative.

Responding to a Data Path Failure When You Are a System Administrator

Under most circumstances, contact your Customer and Technical Support representative any time a path fails and the storage array notifies you of the failure. If your controller has failed and your storage array has customer-replaceable controllers, replace the failed controller. Follow the manufacturer's instructions for how to replace a failed controller.

Responding to a Data Path Failure When You Are a Customer and Technical Support Representative

Use the Recovery Guru in the storage management software to diagnose and fix the problem, if possible. If you cannot fix the problem with the Recovery Guru, follow the manufacturer's instructions for how to replace a failed controller.

Load-Balancing Policies

Load balancing is the redistribution of read/write requests to maximize throughput between the server and the storage array. Load balancing is very important in high workload settings or other settings where consistent service levels are critical. The multi-path driver transparently balances I/O workload without administrator intervention. Without multi-path software, a server sending I/O requests down several paths might operate with very heavy workloads on some paths, while other paths are not used efficiently.

The multi-path driver determines which paths to a device are in an active state and can be used for load balancing. The load-balancing policy uses one of three algorithms: round robin, least queue depth, or least path weight. Multiple options for setting the load-balancing policies let you optimize I/O performance when mixed host interfaces are configured. The load-balancing policies that you can choose depend on your operating system. Load balancing is performed on multiple paths to the same controller but not across both controllers.

Load-Balancing Policies That Are Supported by the Operating Systems

| Operating System | Multi-Path Driver | Load-Balancing Policy |
|---------------------------------|-------------------|--|
| Windows | MPIO DSM | Round robin with subset, least queue depth, weighted paths |
| Red Hat Enterprise Linux (RHEL) | RDAC | Round robin with subset, least queue depth |
| SUSE Linux Enterprise (SLES) | RDAC | Round robin with subset, least queue depth |
| Solaris | MPxIO | Round robin with subset |

Least Queue Depth

The least queue depth policy is also known as the least I/Os policy or the least requests policy. This policy routes the next I/O request to the data path on the controller that owns the volume that has the least outstanding I/O requests queued. For this policy, an I/O request is simply a command in the queue. The type of command or the number of blocks that are associated with the command is not considered. The least queue depth policy treats large block requests and small block requests equally. The data path selected is one of the paths in the path group of the controller that owns the volume.

Round Robin with Subset I/O

The round robin with subset I/O load-balancing policy routes I/O requests, in rotation, to each available data path to the controller that owns the volumes. This policy treats all paths to the controller that owns the volume equally for I/O activity. Paths to the secondary controller are ignored until ownership changes. The basic assumption for the round robin with subset I/O policy is that the data paths are equal. With mixed host support, the data paths might have different bandwidths or different data transfer speeds.

Least Weighted Paths

The least weighted paths policy assigns a weight factor to each data path to a volume. An I/O request is routed to the path with the lowest weight value to the controller that owns the volume. If more than one data path to the volume has the same weight value, the round-robin with subset path selection policy is used to route I/O requests between the paths with the same weight value.

Configuring Failover Drivers for the Windows OS and the Linux OS



NOTE This topic applies to both the Windows OS and the Linux OS.

Dividing I/O Activity Between Two RAID Controllers to Obtain the Best Performance

For the best performance of a redundant controller system, use the storage management software to divide I/O activity between the two RAID controllers in the storage array. You can use either the graphical user interface (GUI) or the command line interface (CLI).

To use the GUI to divide I/O activity between two RAID controllers, perform one of these steps:

- **Specify the owner of the preferred controller of an existing volume** – Select **Volume >> Change >> Ownership/Preferred Path** in the Array Management Window.



NOTE You can also use this method to change the preferred path and ownership of all volumes in a volume group at the same time.

- **Specify the owner of the preferred controller of a volume when you are creating the volume** – Select **Volume >> Create** in the Array Management Window.

To use the CLI, go to the *Create RAID Volume (Free Extent Based Select)* online help topic for the command syntax and description.

Changing the Preferred Path Online Without Stopping the Applications

You can change the preferred path setting for a volume or a set of volumes online and without stopping the applications. If AVT is not enabled, the failover driver uses the new preferred path immediately. However, if AVT is enabled, the failover driver does not recognize that the preferred path has changed until the next cycle of the state change monitor. Therefore, the failover driver might continue to use the old preferred path for up to 60 seconds, or for the period to which the `ScanInterval` parameter is set. Because the failover driver continues to use the non-preferred path for a short period of time, the failover driver might trigger a volume not on preferred path Needs Attention condition in the storage management software. This condition is removed as soon as the state change monitor is run. A MEL event and an associated alert notification are delivered for the volume that is not on preferred path condition. If the failover driver needs some time to recognize that the preferred path has changed, you can configure the AVT alert delay period with the storage management software. The Needs Attention reporting is postponed until the failover driver failback task has had a chance to run.



NOTE The newer versions of the RDAC driver and the DSM driver do not recognize any AVT status change (enabled or disabled) until the next cycle of the state change monitor.

Failover Drivers for the Windows Operating System

The failover driver for hosts with Microsoft Windows operating systems is Microsoft Multipath I/O (MPIO) with a Device Specific Module (DSM) for SANtricity ES Storage Manager.

Microsoft Multipath Input/Output

Microsoft Multipath I/O (MPIO) provides an infrastructure to build highly available solutions for Windows operating systems (OSs). MPIO uses Device Specific Modules (DSMs) to provide I/O routing decisions, error analysis, and failover.

 **NOTE** You can use MPIO for all controllers that run controller firmware version 6.19 or later. MPIO is not supported for any earlier versions of the controller firmware, and MPIO cannot coexist on a server with RDAC. If you have legacy systems that run controller firmware versions earlier than 6.19, you must use RDAC for your failover driver. For SANtricity ES Storage Manager Version 10.10 and later and all versions of SANtricity Storage Manager, the Windows OS supports only MPIO.

Windows OS Restrictions

The MPIO DSM failover driver comes in these versions:

- 32-bit (x86)
- 64-bit Intel (Itanium or IA64)
- 64-bit AMD/EM64T (x64)

These versions are not compatible with each other. Because multiple copies of the driver cannot run on the same system, each subsequent release is backward compatible. In other words, a SANtricity ES Storage Manager Version 10.60 failover driver supports storage management software version 9.23.

You can use the DSM driver for all of the controllers that run controller firmware version 6.19 or later. The DSM driver is not supported for any earlier versions of the controller firmware, and it cannot coexist on a server with RDAC. If you have legacy systems that run controller firmware versions earlier than 6.19, you must use RDAC for your failover driver.

Native SCSI-2 Release/Reservation Commands in a Multipath Environment

If multiple paths exist to a single controller and a SCSI-2 release/reservation (R/R) is received for a volume, the DSM driver selects one path to each controller and repeats the request (called a reservation path). This function is necessary because the controllers cannot accept SCSI-2 R/R requests through multiple paths for a given volume. After the reservation path has been established, subsequent I/O requests for a volume are restricted to that path until a SCSI-2 release command is received. The DSM driver distributes the reservation paths if multiple volumes are mapped to the host, which distributes the load across multiple paths to the same controller.

Translating SCSI-2 Reservation/Release Commands to SCSI-3 Persistent Reservations

The DSM driver also supports the ability to translate the SCSI-2 R/R commands into SCSI-3 persistent reservations. This function allows a volume to use one of the previously mentioned load-balancing policies across all of the available controller paths rather than being restricted to a single reservation path. This

feature requires the DSM driver to establish a unique “reservation key” for each host. This key is stored in the Registry and is named S2toS3Key. If this key is present, translations are performed, or else the “cloning” method is used.

Per-Protocol I/O Timeout Values

The timeout value associated with a non-passthrough I/O requests, such as read/write requests, is based on the Microsoft Disk Driver's `TimeoutValue` parameter, as defined in the Registry. A feature within the DSM allows a customized timeout value to be applied based on the protocol, such as Fibre Channel, SAS, or iSCSI, that a path uses. Per-protocol timeout values provide these benefits:

- Without per-protocol timeout values, the `TimeoutValue` setting is global and affects all storage.
- The `TimeoutValue` is typically reset when an HBA driver is upgraded.
- For Windows Server 2003, the default disk timeout value can be adjusted based on the size of the I/O request. Adjusting the default disk timeout value helps support legacy SCSI devices.
- The DSM customized timeout feature allows a more predictable timeout setting for Windows Server 2003 environments. For information about the configurable parameters for the customized timeout feature, go to [Configuration Settings for Windows DSM and Linux RDAC](#).

The per-protocol timeout values feature slightly modifies the way in which the `SynchTimeout` parameter is evaluated. The `SynchTimeout` parameter determines the I/O timeout for synchronous requests generated by the DSM driver. Examples include the SCSI-2 to SCSI-3 PR translations and inquiry commands used during device discovery. It is important that the timeout value for the requests from the DSM driver be at least as large as the per-protocol I/O timeout value. When a host boots, the DSM driver performs these actions:

- If the value of the `SynchTimeout` parameter is defined in the Registry key of the DSM driver, record the current value.
- If the value of the `TimeoutValue` parameter of the MS driver is defined in the Registry, record the current value.
- Use the higher of the two values as the initial value of the `SynchTimeout` parameter.
- If neither value is defined, use a default value of 10 seconds.
- For each synchronous I/O request, the higher value of either the per-protocol I/O timeout or the `SynchTimeout` parameter is used. For example:
 - If the value of the `SynchTimeout` parameter is 120 seconds, and the value of the `TimeoutValue` parameter is 60 seconds, 120 seconds is used for the initial value.
 - If the value of the `SynchTimeout` parameter is 120 seconds, and the value of the `TimeoutValue` parameter is 180 seconds, 180 seconds is used for the initial value of the synchronous I/O requests for the DSM driver.
 - If the I/O timeout value for a different protocol (for example, SAS) is 60 seconds and the initial value is 120 seconds, the I/O will be sent using a 120-second timeout.

Selective LUN Transfer

This feature limits the conditions under which the DSM will move a LUN to the alternative controller to three cases:

1. When a DSM with a path to only one controller, the non-preferred path, discovers a path to the alternate controller.
2. When an I/O request is directed to a LUN that is owned by the preferred path, but the DSM is attached to only the non-preferred path.

3. When an I/O request is directed to a LUN that is owned by the non-preferred path, but the DSM is attached to only the preferred path.

Case 2 and case 3 have these user-configurable parameters that can be set to tune the behavior of this feature.

- The maximum number of times that the LUN transfer will be issued. This parameter setting prevents a continual ownership thrashing condition from occurring in cases where the controller tray or the controller-drive tray is attached to another host that requires the LUN be owned by the current controller.
- A time delay before LUN transfers are attempted. This parameter is used to de-bounce intermittent I/O path link errors. During the time delay, I/O requests will be retried on the current controller to take advantage of the possibility that another host might transition the LUN to the current controller.

For further information about these two parameters, go to [Configuration Settings for Windows DSM and Linux RDAC](#).

In the case where the host system is connected to both controllers and an I/O is returned with a 94/01 status, in which the LUN is not owned and can be owned, the DSM modifies its internal data on which controller to use for that LUN and reissue the command to the other controller. The DSM does not issue a LUN transfer command to the controller tray or controller-drive tray to avoid interfering with other hosts that might be attached to that controller tray or the controller-drive tray.

When the DSM detects that a volume-transfer operation is required, the DSM does not immediately issue the command. The DSM waits for three seconds before it sends the command to the controller tray or the controller-drive tray. This delay is to attempt to batch together as many volume-transfer operations for other LUNs as possible. This batching method is used because the controller single-threads volume transfer operations and rejects additional transfer commands until the controller has completed the operation on which it is currently working. This single-threading behavior extends the period of time that I/Os are not being successfully serviced by the controller tray or the controller-drive tray.

This feature is enabled when these conditions exist:

- The controller tray or the controller-drive tray does not have AVT enabled.
- The DSM configurable parameter `ClassicModeFailover` is set to 1.
- The DSM configurable parameter `DisableLunRebalance` is set to 4.

Windows Failover Cluster

Clustering for the Windows Server 2008 OS and the Windows Server 2008 R2 OS uses SCSI-3 persistent reservations natively. As a result, the DSM driver does not perform translations for any SCSI-2 R/R commands, and you can use one of the previously mentioned load-balancing policies across all controller paths. Translations still occur if the DSM driver is running in a Windows Server 2003 OS-based environment. When using clustering, set the `DisableLunRebalance` parameter to 3. For information about this parameter, go to [Configuration Settings for Windows DSM and Linux RDAC](#).

Reduced Failover Timing

Settings related to drive I/O timeout and HBA connection loss timeout are adjusted in the host operating system so that failover does not occur when a controller is restarted. These settings provide protection from exception conditions that might occur when both controllers in a controller tray or a controller-drive tray are restarted at the same time, but they have the unfortunate side-effect of causing longer failover times than may be tolerated by some application or clustered environments. Support for the reduced failover timing feature includes support for reduced timeout settings, which result in faster failover response times.

The following restrictions apply to this feature:

- Only the Windows Server 2008 OS and the Windows Server 2008 R2 OS support this feature.
- Non-enterprise products attached to a host must use controller firmware release 7.35 or higher. Enterprise products attached to a host must use controller firmware release 7.6 or higher. For configurations where a mix of earlier releases is installed, older versions are not supported.
- When this feature is used with Windows Server Failover Cluster (WSFC) on the Windows Server 2008 OS, MPIO HotFix 970525 is required. The required HotFix is a standard feature for the Windows Server 2008 R2 OS.

Additional restrictions apply to storage array brownout conditions. Depending on how long the brownout condition lasts, PR registration information for volumes might be lost. By design, WSFC periodically polls the cluster storage to determine the overall health and availability of the resources. One action performed during this polling is a PRIN READ_KEYS request, which returns registration information. Because a brownout condition can cause blank information to be returned, WSFC interprets this as a loss of access to the drive resource and attempts recovery by first failing that drive resource, and then performing a new arbitration.

 **NOTE** Any condition that causes blank registration information to be returned, where previous requests returned valid registration information, can cause the drive resource to fail. If the arbitration succeeds, the resource is brought online. Otherwise, the resource remains in a failed state. One reason for an arbitration failure is the combination of brownout condition and plug-and-play (PnP) timing issues if the HBA timeout period expires. When the timeout period expires, the OS is notified of an HBA change and must re-enumerate the HBAs to determine which devices no longer exist or, in the case where a connection is re-established, what devices are now present.

The arbitration recovery process happens almost immediately after the resource is failed. This situation, along with the PnP timing issue, might result in a failed recovery attempt. Fortunately, you can modify the timing of the recovery process by using the `cluster.exe` command-line tool. Microsoft recommends changing the following, where `resource_name` is a cluster disk resource, such as Cluster Disk 1:

```
cluster.exe resource "resource_name" /prop RestartDelay=4000
```

```
cluster.exe resource "resource_name" /prop RestartThreshold=5
```

The previous example changes the disk-online delay to four seconds and changes the number of online restarts to five. The changes must be repeated for each drive resource. The changes persist across reboots. To display either the current settings or the changed settings, run the following command:

```
cluster.exe resource "resource_name" /prop
```

Another option exists to prevent the storage array from returning blank registration information. This option takes advantage of the Active Persist Through Power Loss (APTPL) feature found in Persistent Reservations, which ensures that the registration information persists through brownout or other conditions related to a power failure. APTPL is enabled when a registration is initially made to the drive resource. WSFC does not use the APTPL feature, but an option is provided in the LSI DSM to set this feature when a registration request is made.

 **IMPORTANT** Because the APTPL feature is not supported in WSFC, Microsoft does not recommend its use. The APTPL feature should be considered as an option of last resort when the `cluster.exe` options cannot meet the tolerances needed. If a cluster setup cannot be brought online successfully after this option is used, the controller shell or SYMBOL commands might be required to clear existing persistent reservations.



NOTE The APTPL feature within the DSM is enabled using the DSM utility with the `-o (feature)` option by setting the `SetAPTPLForPR` option to `1`. According to the SCSI specification, you must set this option before PR registration occurs. If you set this option after a PR registration occurs, take the disk resource offline, and then bring the disk resource back online. If the DSM has set the APTPL option during registration, an internal flag is set, and the DSM utility output from the `-g` option indicates this condition. The SCSI specification does not provide a means for the initiator to query the storage array to determine the current APTPL setting. As a result, the `-g` output from one node might show the option set, but another node might not. Interpret output from the `-g` option with caution. By default, the DSM is released without this option enabled.

Wait Time Settings

When the failover driver receives an I/O request for the first time, the failover driver logs timestamp information for the request. If a request returns an error and the failover driver decides to retry the request, the current time is compared with the original timestamp information. Depending on the error and the amount of time that has elapsed, the request is retried to the current owning controller for the LUN, or a failover is performed and the request sent to the alternate controller. This process is known as a wait time. If the `NotReadyWaitTime` value, the `BusyWaitTime` value, and the `QuiescenceWaitTime` value are greater than the `ControllerIoWaitTime` value, they will have no effect.

For the Linux OS, the configuration settings can be found in the `/etc/mpp.conf` file. For the Windows OS, the configuration settings can be found in the Registry under:

```
HKEY_LOCAL_MACHINE\System\CurrentControlSet\ Services\<DSM_Driver>
```

In the preceding setting, `<DSM_Driver>` is the name of the OEM-specific driver. The default driver is named `mppdsm.sys`. Any changes to the settings take effect the next time the host is restarted.



ATTENTION Possible loss of data access – If you change these settings from their configured values, you might lose access to the storage array.

Configuration Settings for the Path Congestion Detection Feature

| Parameter Name | Default Value (Operating System) | Description |
|-----------------------------------|----------------------------------|--|
| <code>NotReadyWaitTime</code> | 300 (Windows) 270 (Linux) | The time, in seconds, a Not Ready condition (SK 0x06, ASC/ASCQ 0x04/0x01) is allowed before failover is performed. Valid values range from <code>0x1</code> to <code>0xFFFFFFFF</code> . |
| <code>BusyWaitTime</code> | 600 (Windows) 270 (Linux) | The time, in seconds, a Busy condition is allowed before a failover is performed. Valid values range from <code>0x1</code> to <code>0xFFFFFFFF</code> . |
| <code>QuiescenceWaitTime</code> | 600 (Windows) 270 (Linux) | The time, in seconds, a Busy condition is allowed before a failover is performed. Valid values range from <code>0x1</code> to <code>0xFFFFFFFF</code> . |
| <code>ControllerIoWaitTime</code> | 600 (Windows) 120 (Linux) | Provides an upper-bound limit, in seconds, that an I/O is retried on a controller regardless of the retry status before a failover is performed. If the limit is exceeded on the |

| Parameter Name | Default Value (Operating System) | Description |
|------------------------------|---------------------------------------|--|
| | | alternate controller, the I/O is again attempted on the original controller. This process continues until the value of the <code>ArrayIoWaitTime</code> limit is reached. Valid values range from <code>0x1</code> to <code>0xFFFFFFFF</code> . |
| <code>ArrayIoWaitTime</code> | 600 (Windows DSM) 600 (Linux RDAC) | Provides an upper-bound limit, in seconds, that an I/O is retried to the storage array regardless of to which controller the request is attempted. After this limit is exceeded, the I/O is returned with a failure status. Valid values range from <code>0x1</code> to <code>0xFFFFFFFF</code> . |

Path Congestion Detection and Online/Offline Path States

The path congestion detection feature allows the DSM driver to place a path offline based on the path I/O latency. The DSM automatically sets a path offline when I/O response times exceed user-definable congestion criteria. An administrator can manually place a path into the Admin Offline state. When a path is either set offline by the DSM or by an administrator, I/O is routed to a different path. The offline or admin offline path is not used for I/O until the system administrator sets the path online.

For more information on path congestion configurable parameters, go to [Configuration Settings for Windows DSM and Linux RDAC](#).

Configuration Settings for Windows DSM and Linux RDAC

This topic applies to both the Windows OS and the Linux OS. The failover driver that is provided with the storage management software contains configuration settings that can modify the behavior of the driver.

- For the Linux OS, the configuration settings are in the `/etc/mpp.conf` file.
- For the Windows OS, the configuration settings are in the `HKEY_LOCAL_MACHINE\System\CurrentControlSet\Services\<DSM_Driver>\Parameters` registry key, where `<DSM_Driver>` is the name of the OEM-specific driver.

The default failover driver is `mppdsm.sys`. Any changes to the settings take effect on the next reboot of the host.

The default values listed in the following table apply to both the Windows OS and the Linux OS unless the OS is specified in parentheses. Many of these values are overridden by the failover installer for the Linux OS or the Windows OS.

 **ATTENTION Possible loss of data access** – If you change these settings from their configured values, you might lose access to the storage array.

Configuration Settings for Windows DSM and Linux RDAC

| Parmeter Name | Default Value (Operating System) | Description |
|----------------------------|----------------------------------|--|
| MaxPathsPerController | 4 | The maximum number of paths (logical endpoints) that are supported per controller. The total number of paths to the storage array is the <code>MaxPathsPerController</code> value multiplied by the number of controllers. The allowed values range from <code>0x1</code> (1) to <code>0x20</code> (32) for the Windows OS , and from <code>0x1</code> (1) to <code>0xFF</code> (255) for Linux RDAC. For use by Customer and Technical Support representatives only. |
| ScanInterval | 1 (Windows) 60 (Linux) | The interval time, in seconds, that the failover driver checks for these conditions: <ul style="list-style-type: none"> A change in preferred ownership for a LUN An attempt to rebalance LUNs to their preferred paths A change in AVT-enabled status or AVT-disabled status For the Windows OS, the allowed values range from <code>0x1</code> to <code>0xFFFFFFFF</code> and must be specified in minutes. For the Linux OSs, the allowed values range from <code>0x1</code> to <code>0xFFFFFFFF</code> and must be specified in seconds. For use by Customer and Technical Support representatives only. |
| ErrorLevel | 3 | This setting determines which errors to log. These values are valid: <ul style="list-style-type: none"> 0 – Display all errors 1 – Display path failover errors, controller failover errors, retryable errors, fatal errors, and recovered errors 2 – Display path failover errors, controller failover errors, retryable errors, and fatal errors 3 – Display path failover errors, controller failover errors, and fatal errors 4 – Display controller failover errors, and fatal errors For use by Customer and Technical Support representatives only. |
| SelectionTimeoutRetryCount | 0 | The number of times a selection timeout is retried for an I/O request before the path fails. If another path to the same controller exists, the I/O is retried. If no other path |

| Parameter Name | Default Value (Operating System) | Description |
|--------------------------|----------------------------------|--|
| | | <p>to the same controller exists, a failover takes place. If no valid paths exist to the alternate controller, the I/O is failed.</p> <p>The allowed values range from 0x0 to 0xFFFFFFFF. For use by Customer and Technical Support representatives only.</p> |
| CommandTimeoutRetryCount | 1 | <p>The number of times a command timeout is retried for an I/O request before the path fails. If another path to the same controller exists, the I/O is retried. If another path to the same controller does not exist, a failover takes place. If no valid paths exist to the alternate controller, the I/O is failed.</p> <p>The allowed values range from 0x0 to 0xa (10) for the Windows OS, and from 0x0 to 0xFFFFFFFF for Linux RDAC.</p> <p>For use by Customer and Technical Support representatives only.</p> |
| UaRetryCount | 10 | <p>The number of times a Unit Attention (UA) status from a LUN is retried. This parameter does not apply to UA conditions due to Quiescence In Progress.</p> <p>The allowed values range from 0x0 to 0x64 (100) for the Windows OS, and from 0x0 to 0xFFFFFFFF for Linux RDAC.</p> <p>For use by Customer and Technical Support representatives only.</p> |
| SynchTimeout | 120 | <p>The timeout, in seconds, for synchronous I/O requests that are generated internally by the failover driver. Examples of internal requests include those related to rebalancing, path validation, and issuing of failover commands.</p> <p>The allowed values range from 0x1 to 0xFFFFFFFF. For use by Customer and Technical Support representatives only.</p> |
| DisableLunRebalance | 0 | <p>This parameter provides control over the LUN fallback behavior of rebalancing LUNs to their preferred paths. These values are possible:</p> <ul style="list-style-type: none"> ▪ 0 – LUN rebalance is enabled for both AVT and non-AVT modes. ▪ 1 – LUN rebalance is disabled for AVT mode and enabled for non-AVT mode. ▪ 2 – LUN rebalance is enabled for AVT mode and disabled for non-AVT mode. ▪ 3 – LUN rebalance is disabled for both AVT and non-AVT modes. |

| Parameter Name | Default Value (Operating System) | Description |
|--|----------------------------------|---|
| | | <ul style="list-style-type: none"> 4 – The selective LUN Transfer feature is enabled if AVT mode is off and <code>ClassicModeFailover</code> is set to LUN level 1. |
| <code>S2ToS3Key</code> | Unique key | <p>This value is the SCSI-3 reservation key generated during failover driver installation.</p> <hr/> <p>NOTE For use by Customer and Technical Support representatives only.</p> <hr/> |
| <code>LoadBalancePolicy</code> | 1 | <p>This parameter determines the load-balancing policy used by all volumes managed by the Windows DSM and Linux RDAC failover drivers. These values are valid:</p> <ul style="list-style-type: none"> 0 – Round robin with subset. 1 – Least queue depth with subset. 2 – Least path weight with subset (Windows OS only). |
| <code>ClassicModeFailover</code> | 0 | <p>This parameter provides control over how the DSM handles failover situations. These values are valid:</p> <ul style="list-style-type: none"> 0 – Perform controller-level failover (all LUNs are moved to the alternate controller). 1 – Perform LUN-level failover (only the LUNs indicating errors are transferred to the alternate controller). |
| <code>SelectiveTransferMaxTransfer Attempts</code> | 3 | <p>This parameter sets the maximum number of times that a host transfers the ownership of a LUN to the alternate controller when the Selective LUN Transfer mode is enabled. This setting prevents multiple hosts from continually transferring LUNs between controllers.</p> |
| <code>SelectiveTransferMinIOWaitTime</code> | 5 | <p>This parameter sets the minimum wait time (in seconds) that the DSM waits before transferring a LUN to the alternate controller when the Selective LUN Transfer mode is enabled. This parameter tries to stop excessive LUN transfers due to intermittent link errors.</p> |

Example Configuration Settings for the Path Congestion Detection Feature



IMPORTANT Before path congestion detection can be enabled, you must set the `CongestionResponseTime`, `CongestionTimeFrame`, and `CongestionSamplingInterval` parameters to valid values.

To set the path congestion IO response time to 10 seconds:

```
dsmUtil -o CongestionResponseTime=10,SaveSettings
```

To set the path congestion sampling interval to one minute:

```
dsmUtil -o CongestionSamplingInterval=60
```

To enable path congestion detection:

```
dsmUtil -o CongestionDetectionEnabled=0x1,SaveSettings
```

To use the `dsmUtil -o` command to set a path to Admin Offline:

```
dsmUtil -o SetPathOffline=0x77070001
```



NOTE The path ID (in this example 0x77070001) is found using the `dsmUtil -g` command.

To use the `dsmUtil -o` command to set a path to online:

```
dsmUtil -o SetPathOnline=0x77070001
```

Device Specific Module for the Microsoft MPIO Solution

The DSM driver is the hardware-specific part of Microsoft's MPIO solution. This release supports Microsoft's Windows Server 2003 OS, Windows Server 2008 OS, and Windows Server 2008 R2 OS. The Hyper-V role is also supported when running the DSM within the parent partition. The DSM provides this support for SANtricity ES Storage Manager Version 10.80.

The directory structures concerning the DSM driver include these paths:

- `\Device\MPPDSM` – This structure contains information that is maintained by the DSM driver.
- `\Device\Scsi` – This structure contains information that is maintained by the ScsiPort driver.

The name MPPDSM might be different when a non-LSI-generic solution is installed.

Object Path and Descriptions of the WinObj DSM

| Object Path | Description |
|--|---|
| <code>\Device\MPPDSM</code> | The root directory for all named objects that are created by the DSM driver. |
| <code>\Device\MPPDSM\<storage array></code> | The root directory for all named objects that are created by the storage array named <code><storage array></code> . |
| <code>\Device\MPPDSM\<storage array> \<ctrl></code> | The root directory for all named objects that are created for a given controller. The <code><ctrl></code> value can either be A or B. |
| <code>\Device\MPPDSM\<storage array> \<ctrl>\ P<port>P<path>I<id></code> | The root directory for all named objects that are created for a given path to a controller. The <code><port></code> value, the <code><path></code> value, and the <code><id></code> value represent a SCSI address from a given HBA port. |

| Object Path | Description |
|---|---|
| \Device\Scsi | The root directory for all of the named objects created by the ScsiPort driver. Each object represents a physical path found by a given HBA. |
| \Device\Scsi\ <i><adapter></i> Port <i><port></i> \Path <i><path></i> Target <i><target></i> Lun <i><lun></i> | ScsiPort-based HBA drivers. A named device object that represents a drive. The <i><adapter></i> value represents the HBA vendor. For QLogic, this value is based on the HBA model number (for example, ql2300). The <i><port></i> value, the <i><path></i> value, and the <i><target></i> value represent the location of the volume on the HBA. |
| \Device\ <i><auto-generated id></i> | StorPort-based HBA drivers. An auto-generated named device object representing a drive. |

With this information, you can reach these conclusions:

- The objects shown in the \Device\Scsi directory show the physical volumes that are identified by the HBAs. If a specific volume is not in this list, the DSM driver cannot detect the volumes.
- The objects shown in the \Device\MPPDSM directory show the items that are reported by MPIO to the DSM driver. If a device is not in this list, MPIO has not notified the DSM driver.

Device Specific Module Driver Directory Structures



NOTE The name MPPDSM in the directory structures might be different based on your network configuration.

The directory structures for the DSM driver include these paths:

- \Device\MPPDSM – This structure contains information that is maintained by the DSM driver. The objects shown in the \Device\MPPDSM directory in the following table show the items that are reported by MPIO to the DSM driver. If a device is not in this list, MPIO has not notified the DSM driver.
- \Device\Scsi – This structure contains information that is maintained by the ScsiPort driver. The objects shown in the \Device\Scsi directory in the following table show the physical volumes that are identified by the HBAs. If a specific volume is not in this list, the DSM driver cannot detect the volumes.

Object Path and Descriptions of the WinObj DSM

| Object Path | Description |
|--|---|
| Device\MPPDSM | The root directory for all named objects that are created by the DSM driver. |
| \Device\MPPDSM\ <i><storage array></i> | The root directory for all named objects that are created by the storage array named <i><storage array></i> . |

| Object Path | Description |
|--|---|
| \Device\MPPDSM\ <i><storage array></i> | The root directory for all named objects that are created by the storage array named <i><storage array></i> . |
| \Device\MPPDSM\ <i><storage array></i> \<ctrl> | The root directory for all named objects that are created for a given controller. The <i><ctrl></i> value can either be A or B. |
| \Device\MPPDSM\ <i><storage array></i> \<ctrl>\ P<port>P<path>I<id> | The root directory for all named objects that are created for a given path to a controller. The <i><port></i> value, the <i><path></i> value, and the <i><id></i> value represent a SCSI address from a given HBA port. |
| \Device\MPPDSM\ <i><storage array></i> \<ctrl>\ P<port>P<path>I<id>\<lun> | The <i><lun></i> value represents the volume number assigned to the device for a given controller/path combination. |
| \Device\Scsi | The root directory for all of the named objects created by the ScsiPort driver. Each object represents a physical path found by a given HBA. |
| \Device\Scsi\ <i><adapter></i> Port<port>\ Path<path>Target<target>Lun<lun> | ScsiPort-based HBA drivers. A named device object that represents a drive. The <i><adapter></i> value represents the HBA vendor. For QLogic, this value is based on the HBA model number (for example, ql2300). The <i><port></i> value, the <i><path></i> value, and the <i><target></i> value represent the location of the volume on the HBA. |
| \Device\ <i><auto-generated id></i> | StorPort-based HBA drivers. An auto-generated named device object representing a drive. |

dsmUtil Utility

The dsmUtil utility is a command-line driven utility that works only with the Multipath I/O (MPIO) Device Specific Module (DSM) solution. The utility is used primarily as to tell the DSM driver to perform various maintenance tasks, but the utility can also serve as a troubleshooting tool when necessary.

Configuration Settings for Windows DSM and Linux RDAC

This topic applies to both the Windows OS and the Linux OS. The failover driver that is provided with the storage management software contains configuration settings that can modify the behavior of the driver.

- For the Linux OS, the configuration settings are in the `/etc/mpp.conf` file.
- For the Windows OS, the configuration settings are in the `HKEY_LOCAL_MACHINE\System\CurrentControlSet\Services\<DSM_Driver>\Parameters` registry key, where *<DSM_Driver>* is the name of the OEM-specific driver.

The default failover driver is `mppdsm.sys`. Any changes to the settings take effect on the next reboot of the host.

The default values listed in the following table apply to both the Windows OS and the Linux OS unless the OS is specified in parentheses. Many of these values are overridden by the failover installer for the Linux OS or the Windows OS.

 **ATTENTION Possible loss of data access** – If you change these settings from their configured values, you might lose access to the storage array.

Configuration Settings for Windows DSM and Linux RDAC

| Parameter Name | Default Value (Operating System) | Description |
|------------------------------------|----------------------------------|--|
| <code>MaxPathsPerController</code> | 4 | The maximum number of paths (logical endpoints) that are supported per controller. The total number of paths to the storage array is the <code>MaxPathsPerController</code> value multiplied by the number of controllers. The allowed values range from <code>0x1</code> (1) to <code>0x20</code> (32) for the Windows OS, and from <code>0x1</code> (1) to <code>0xFF</code> (255) for Linux RDAC. For use by Customer and Technical Support representatives only. |
| <code>ScanInterval</code> | 1 (Windows) 60 (Linux) | The interval time, in seconds, that the failover driver checks for these conditions: <ul style="list-style-type: none"> ▪ A change in preferred ownership for a LUN ▪ An attempt to rebalance LUNs to their preferred paths ▪ A change in AVT-enabled status or AVT-disabled status For the Windows OS, the allowed values range from <code>0x1</code> to <code>0xFFFFFFFF</code> and must be specified in minutes. For the Linux OSs, the allowed values range from <code>0x1</code> to <code>0xFFFFFFFF</code> and must be specified in seconds. For use by Customer and Technical Support representatives only. |
| <code>ErrorLevel</code> | 3 | This setting determines which errors to log. These values are valid: <ul style="list-style-type: none"> ▪ 0 – Display all errors ▪ 1 – Display path failover errors, controller failover errors, retryable errors, fatal errors, and recovered errors ▪ 2 – Display path failover errors, controller failover errors, retryable errors, and fatal errors ▪ 3 – Display path failover errors, controller failover errors, and fatal errors |

| Parmeter Name | Default Value (Operating System) | Description |
|----------------------------|----------------------------------|---|
| | | <ul style="list-style-type: none"> ▪ 4 – Display controller failover errors, and fatal errors For use by Customer and Technical Support representatives only. |
| SelectionTimeoutRetryCount | 0 | The number of times a selection timeout is retried for an I/O request before the path fails. If another path to the same controller exists, the I/O is retried. If no other path to the same controller exists, a failover takes place. If no valid paths exist to the alternate controller, the I/O is failed. The allowed values range from 0x0 to 0xFFFFFFFF. For use by Customer and Technical Support representatives only. |
| CommandTimeoutRetryCount | 1 | The number of times a command timeout is retried for an I/O request before the path fails. If another path to the same controller exists, the I/O is retried. If another path to the same controller does not exist, a failover takes place. If no valid paths exist to the alternate controller, the I/O is failed. The allowed values range from 0x0 to 0xa (10) for the Windows OS, and from 0x0 to 0xFFFFFFFF for Linux RDAC. For use by Customer and Technical Support representatives only. |
| UaRetryCount | 10 | The number of times a Unit Attention (UA) status from a LUN is retried. This parameter does not apply to UA conditions due to Quiescence In Progress. The allowed values range from 0x0 to 0x64 (100) for the Windows OS, and from 0x0 to 0xFFFFFFFF for Linux RDAC. For use by Customer and Technical Support representatives only. |
| SynchTimeout | 120 | The timeout, in seconds, for synchronous I/O requests that are generated internally by the failover driver. Examples of internal requests include those related to rebalancing, path validation, and issuing of failover commands. The allowed values range from 0x1 to 0xFFFFFFFF. For use by Customer and Technical Support representatives only. |
| DisableLunRebalance | 0 | This parameter provides control over the LUN failback behavior of rebalancing LUNs to their preferred paths. These values are possible: <ul style="list-style-type: none"> ▪ 0 – LUN rebalance is enabled for both AVT and non-AVT modes. |

| Parmeter Name | Default Value (Operating System) | Description |
|--|----------------------------------|---|
| | | <ul style="list-style-type: none"> ▪ 1 – LUN rebalance is disabled for AVT mode and enabled for non-AVT mode. ▪ 2 – LUN rebalance is enabled for AVT mode and disabled for non-AVT mode. ▪ 3 – LUN rebalance is disabled for both AVT and non-AVT modes. ▪ 4 – The selective LUN Transfer feature is enabled if AVT mode is off and <code>ClassicModeFailover</code> is set to LUN level 1. |
| <code>S2ToS3Key</code> | Unique key | <p>This value is the SCSI-3 reservation key generated during failover driver installation.</p> <hr/> <p>NOTE For use by Customer and Technical Support representatives only.</p> <hr/> |
| <code>LoadBalancePolicy</code> | 1 | <p>This parameter determines the load-balancing policy used by all volumes managed by the Windows DSM and Linux RDAC failover drivers. These values are valid:</p> <ul style="list-style-type: none"> ▪ 0 – Round robin with subset. ▪ 1 – Least queue depth with subset. ▪ 2 – Least path weight with subset (Windows OS only). |
| <code>ClassicModeFailover</code> | 0 | <p>This parameter provides control over how the DSM handles failover situations. These values are valid:</p> <ul style="list-style-type: none"> ▪ 0 – Perform controller-level failover (all LUNs are moved to the alternate controller). ▪ 1 – Perform LUN-level failover (only the LUNs indicating errors are transferred to the alternate controller). |
| <code>SelectiveTransferMaxTransfer Attempts</code> | 3 | <p>This parameter sets the maximum number of times that a host transfers the ownership of a LUN to the alternate controller when the Selective LUN Transfer mode is enabled. This setting prevents multiple hosts from continually transferring LUNs between controllers.</p> |
| <code>SelectiveTransferMinIOWaitTime</code> | 5 | <p>This parameter sets the minimum wait time (in seconds) that the DSM waits before transferring a LUN to the alternate controller when the Selective LUN Transfer mode is enabled. This parameter tries to stop excessive LUN transfers due to intermittent link errors.</p> |

Windows DSM Configuration Settings

The following configuration settings are applied using the utility `dsmUtil -o` option parameter. Go to [Configuration Settings for Windows DSM and Linux RDAC](#).

Configuration Settings for the Path Congestion Detection Feature

| Parameter Name | Default Value | Description |
|--|------------------|--|
| <code>CongestionDetectionEnabled</code> | <code>0x0</code> | A Boolean value that indicates whether the path congestion detection is enabled. If this parameter is not defined or is set to <code>0x0</code> , the value is false, the path congestion feature is disabled, and all of the other parameters are ignored. If set to <code>0x1</code> , the path congestion feature is enabled. Valid values are <code>0x0</code> or <code>0x1</code> . |
| <code>CongestionResponseTime</code> | <code>0x0</code> | If <code>CongestionIoCount</code> is <code>0x0</code> or not defined, this parameter represents an average response time in seconds allowed for an I/O request. If the value of the <code>CongestionIoCount</code> parameter is nonzero, then this parameter is the absolute time allowed for an I/O request. Valid values range from <code>0x1</code> to <code>0x10000</code> (approximately 18 hours). |
| <code>CongestionIoCount</code> | <code>0x0</code> | The number of I/O requests that have exceeded the value of the <code>CongestionResponseTime</code> parameter within the value of the <code>CongestionTimeFrame</code> parameter. Valid values range from <code>0x0</code> to <code>0x10000</code> (approximately 4000 requests). |
| <code>CongestionTimeFrame</code> | <code>0x0</code> | A sliding window that defines the time period that is evaluated in seconds. If this parameter is not defined or is set to <code>0x0</code> , the path congestion feature is disabled because no time frame has been defined. Valid values range from <code>0x1</code> to <code>0x1C20</code> (approximately two hours). |
| <code>CongestionSamplingInterval</code> | <code>0x0</code> | The number of I/O requests that must be sent to a path before the <i>n</i> th request is used in the average response time calculation. For example, if this parameter is set to <code>100</code> , every 100th request sent to a path is used in the average response time calculation. If this parameter is set to <code>0x0</code> or not defined, the path congestion feature is disabled for performance reasons—every I/O request would incur a calculation. Valid values range from <code>0x1</code> to <code>0xFFFFFFFF</code> (approximately 4 billion requests). |
| <code>CongestionMinPopulationSize</code> | <code>0x0</code> | The number of sampled I/O requests that must be collected before the average response time is calculated. Valid values range from <code>0x1</code> to <code>0xFFFFFFFF</code> (approximately 4 billion requests). |

| Parameter Name | Default Value | Description |
|-------------------------------|---------------|---|
| CongestionTakeLastPathOffline | 0x0 | <p>A Boolean value that indicates whether the DSM driver takes the last path available to the storage array offline if the congestion thresholds have been exceeded. If this parameter is not defined or is set to 0x0, the value is false. Valid values are 0x0 or 0x1.</p> <hr/> <p>NOTE Setting a path offline with the dsmUtil utility succeeds regardless of the setting of this value.</p> |

dsmUtil Utility

The dsmUtil utility is a command-line driven utility that works only with the Multipath I/O (MPIO) Device Specific Module (DSM) solution. The utility is used primarily as a way to instruct the DSM driver to perform various maintenance tasks, but the utility can also serve as a troubleshooting tool when necessary.

To use the dsmUtil utility, type this command, and press **Enter**:

```
dsmUtil [[-a [target_id]]
[-c array_name | missing]
[-d debug_level] [-e error_level] [-g virtual_target_id]
[-o [[feature_action_name[=value]] | [feature_variable_name=value]][, SaveSettings]] [-
-P [GetMpioParameters | MpioParameter=value | ...]] [-R]
[-s "failback" | "avt" | "busscan" | "forcerebalance"]
[-w target_wwn, controller_index]
```



IMPORTANT The quotation marks must surround the parameters.

Typing `dsmUtil` without any parameters shows the usage information.

The following table shows the dsmUtil parameters.

dsmUtil Parameters

| Parameter | Description |
|----------------|--|
| -a [target_id] | <p>Shows a summary of all storage arrays seen by the DSM. The summary shows the <i>target_id</i>, the storage array WWID, and the storage array name. If <i>target_id</i> is specified, DSM point-in-time state information appears for the storage array. On UNIX operating systems, the virtual HBA specifies unique target IDs for each storage array. The Windows MPIO virtual HBA driver does not use target IDs. The parameter for this option can be viewed as an offset into the DSM information structures, with each offset representing a different storage array.</p> <hr/> <p>NOTE For use by Customer and Technical Support representatives only.</p> |

| Parameter | Description |
|-------------------------|--|
| -c array_name missing | <p>Clears the WWN file entries. This file is located in the Program Files\DSMDrivers\mppdsm\WWN_FILES directory with the extension .wnn. If the array_name keyword is specified, the WWN file for the specific storage array is deleted. If the missing keyword is used, all WWN files for previously attached storage arrays are deleted. If neither keyword is used, all of the WWN files, for both currently attached and previously attached storage arrays, are deleted.</p> |
| -d debug_level | <p>Sets the current debug reporting level. This option only works if the RDAC driver has been compiled with debugging enabled. Debug reporting is comprised of two segments. The first segment refers to a specific area of functionality, and the second segment refers to the level of reporting within that area. The debug_level is one of these hexadecimal numbers:</p> <ul style="list-style-type: none"> ▪ 0x20000000 – Shows messages from the RDAC driver's initialization routine. ▪ 0x10000000 – Shows messages from the RDAC driver's device discovery routine. ▪ 0x08000000 – Shows messages from the RDAC driver's ioctl() routine. ▪ 0x04000000 – Shows messages from the RDAC driver's device open routine (Linux platforms only). ▪ 0x02000000 – Shows messages from the RDAC driver's device read routine (Linux platforms only). ▪ 0x01000000 – Shows messages related to HBA commands. ▪ 0x00800000 – Shows messages related to aborted commands. ▪ x00400000 – Shows messages related to panic dumps. ▪ 0x00200000 – Shows messages related to synchronous I/O activity. ▪ 0x00100000 – Shows messages related to failover activity. ▪ 0x00080000 – Shows messages related to failback activity. ▪ 0x00040000 – Shows additional messages related to failback activity. ▪ 0x00010000 – Shows messages related to device removals. ▪ 0x00001000 – Shows messages related to SCSI reservation activity. ▪ 0x00000400 – Shows messages related to path validation activity. ▪ 0x00000001 – Debug level 1. ▪ 0x00000002 – Debug level 2. ▪ 0x00000004 – Debug level 3. |

| Parameter | Description |
|---|--|
| | <ul style="list-style-type: none"> 0x00000008 – Debug level 4. <p>You can combine these options with the logical or operator to provide multiple areas and levels of reporting as needed.</p> <hr/> <p>NOTE For use by Customer and Technical Support representatives only.</p> <hr/> |
| <code>-e error_level</code> | <p>Sets the current error reporting level to <i>error_level</i>, which can have one of these values:</p> <ul style="list-style-type: none"> 0 – Show all errors. 1 – Show path failover, controller failover, retryable, fatal, and recovered errors. 2 – Show path failover, controller failover, retryable, and fatal errors. 3 – Show path failover, controller failover, and fatal errors. This is the default setting. 4 – Show controller failover and fatal errors. 5 – Show fatal errors. <p>For use by Customer and Technical Support representatives only.</p> |
| <code>-g target_id</code> | <p>Displays detailed information about the state of each controller, path, and LUNs for for the specified storage array. You can find the <i>target_id</i> by running the <code>dsmUtil -a</code> command.</p> |
| <code>-M</code> | <p>Shows the MPIO disk-to-drive mappings for the DSM. The output is similar to that found with the SMdevices utility.</p> <p>For use by Customer and Technical Support representatives only.</p> |
| <code>-o</code> [[<i>feature_action_name</i> [= <i>value</i>]] [[<i>feature_variable_name</i> = <i>value</i>]] [, SaveSettings] | <p>Troubleshoots a feature or changes a configuration setting.</p> <p>Without the <code>SaveSettings</code> keyword, the changes only affect the in-memory state of the variable. The <code>SaveSettings</code> keyword changes both the in-memory state and the persistent state. Some example commands are:</p> <ul style="list-style-type: none"> <code>dsmUtil -o</code> – Displays all the available feature action names. <code>dsmUtil -o DisableLunRebalance=0x3</code> – Turns off the DSM-initiated storage array LUN rebalance (affects only the in-memory state). |
| <code>-P [GetMpioParameters MpioParameter=<i>value</i> ...]</code> | <p>Displays and sets MPIO parameters.</p> <hr/> <p>NOTE For use by Customer and Technical Support representatives only.</p> <hr/> |
| <code>-R</code> | <p>Remove the load-balancing policy settings for inactive devices.</p> |

| Parameter | Description |
|--|--|
| -s ["failback" "avt" "busscan" "forcerebalance"] | Manually initiates one of the DSM driver's scan tasks. A "failback" scan causes the DSM driver to reattempt communications with any failed controllers. An "avt" scan causes the DSM driver to check whether AVT has been enabled or disabled for an entire storage array. A "busscan" scan causes the DSM driver to go through its unconfigured devices list to see if any of them have become configured. A "forcerebalance" scan causes the DSM driver to move storage array volumes to their preferred controller and ignores the value of the <code>DisableLunRebalance</code> configuration parameter of the DSM driver. |
| -w <i>target_wwn</i> , <i>controller_index</i> | For use by Customer and Technical Support representatives only. |

Device Manager

Device Manager is part of the Windows operating system. Select **Control Panel** from the **Start** menu. Then select **Administrative Tools > Computer Management > Device Manager**.

The Device Manager tree for MPIO is similar to the one for RDAC. One difference is the names that are associated with the volumes. In RDAC, the volumes are identified with a label, such as the RDAC Volume. In MPIO, the volumes are named based on the vendor information and product ID information of the underlying physical device, along with the text Multi-Path Disk Device.

Scroll down to System Devices to view information about the DSM driver itself. This name might be different based on your network configuration.

The Drives section shows both the drives identified with the HBA drivers and the volumes created by MPIO. Select one of the MPIO volumes, and right-click it. Select **Properties** to open the **Multi-Path Disk Device Properties** window.

This properties window shows if the device is working correctly. Select the **Driver** tab to view the driver information.

Determining if a Path Has Failed

If a single path to a controller that has multiple paths fails, the failover driver makes an entry in the OS system log that indicates a path failure. In the storage management software, the storage array shows a Degraded status.

If all of the paths to a controller fail, the failover driver makes entries in the OS system log that indicate a path failure and failover. In the storage management software, the storage array shows a Needs Attention condition of Volume not on preferred path. The failover event is also written to the Major Event Log (MEL). In addition, if the administrator has configured alert notifications, email messages, or SNMP traps, messages are posted for this condition. The Recovery Guru in the storage management software provides more information about the path failure, along with instructions about how to correct the problem.



NOTE Alert reporting for the Volume not on preferred path condition can be delayed if you set the failover alert delay parameter through the storage management software. When you set this parameter, it imposes a delay on the setting of the Needs Attention condition in the storage management software.

Frequently Asked Questions about Windows Failover Drivers

Frequently Asked Questions about Windows Failover Drivers

| Question | Answer |
|---|--|
| My disk devices or host bus adapters (HBAs) show a yellow exclamation point. What does this mean? | When you use Device Manager, you might observe that a disk device icon or an HBA icon has a yellow exclamation point on it. If new volumes have been mapped to the host, the exclamation point might appear on the icon for a few seconds. This action occurs because the PnP Manager is reconfiguring the device, and, during this time, the device or the HBA might not be used. If the exclamation point stays for more than one minute, a configuration error has occurred. |
| My disk devices or HBAs show a red X. What does this mean? | When you use Device Manager, you might notice that a disk device icon or an HBA icon has a red X on it. This X indicates that the device has been disabled. A disabled device cannot be used or communicated with until it is re-enabled. If the disabled device is an adapter, any disk devices that were connected to that adapter are removed from Device Manager. |
| Why does the SMdevices utility not show any volumes? | <p>If the SMdevices utility does not show any volumes, perform these steps:</p> <ol style="list-style-type: none"> 1. Make sure that all cables are seated correctly. Make sure that all gigabit interface converters (GBICs) are seated correctly. 2. Determine the HBA BIOS and driver versions that the system uses, and make sure that the HBA BIOS and driver versions are correct. 3. Make sure that your mappings are correct. Do not use any HBA mapping tools. 4. Use WinObj to determine if the host has detected the volumes. <p>If the host has not detected the volumes, an HBA problem or a controller problem has occurred. Make sure that the HBAs are logging into the switch or the controller. If they are not logging in, the problem is probably HBA related. If the HBAs have logged into the controller, a controller issue might be the problem.</p> |
| The SMdevices utility shows duplicate entries for some or all of my disks. | You see that some of your disks show up twice when you run the SMdevices utility. For the Windows Server OS, something went wrong with the device-claiming process. |
| I run the hot_add utility, but my disks do not appear. | See "Why does the SMdevices utility not show any volumes?" |

| Question | Answer |
|--|---|
| I have mapped new volumes to my host, but I cannot see them. | Run the hot_add utility. See "Why does the SMdevices utility not show any volumes?" |
| How do I know if a host has detected my volumes? | Use WinObj to determine if the host can see the volumes. <ul style="list-style-type: none"> ▪ If the host cannot see the volumes, an HBA problem or a controller problem has occurred. ▪ Make sure that the HBAs log into the switch or the controller. If they are not logging in correctly, the problem is probably HBA related. ▪ If the HBAs have logged into the controller, the problem might be a controller issue. |
| When I boot my system, I get a "Registry Corrupted" message. | Refer to the Microsoft Knowledge Base article 277222 at http://support.microsoft.com/kb/277222/en-us . Registry limitations can result in devices and paths that are not recognizable by the host OS and the failover driver. |
| My controller failover test does not fail over. | Make sure that you have looked through the rest of this document for the problem. If you think that the problem is still RDAC-related or DSM-related, contact a Customer and Technical Support representative. |
| After I install the DSM driver, my system takes a long time to start. Why? | You might still experience long start times after you install the DSM driver because the Windows OS is completing its configuration for each device. For example, you install the DSM driver on a host with no storage array attached, and you restart the host. Before the Windows OS actually starts, you plug in a cable to a storage array with 32 volumes. In the start-up process, PnP detects the configuration change and starts to process it. After the configuration change has completed, subsequent restarts do not experience any delays unless additional configuration changes are detected. The same process can occur even if the host has already started. |
| What host type must I use for the MPIO solution? | If you use Microsoft Cluster Server, select a host type of the Windows 2003/2008 Clustered OS. If you do not use Microsoft Cluster Server, select a host type of the Windows 2003/2008 Non-Clustered OS. |
| How can I tell if MPIO is installed? | Perform these steps: <ol style="list-style-type: none"> 1. Go to the Control Panel on the Start menu, and double-click Administrative Tools. 2. Select Computer Management > Device Manager > SCSI and RAID controllers. |

| Question | Answer |
|--|---|
| | <p>3. On the Windows Server 2003 OS , look for Multi-Path Support. On the Windows Server 2008 OS, look for Microsoft Multi-Path Bus Driver. If one of these items is present, MPIO is installed.</p> |
| <p>How can I tell if the DSM driver is installed?</p> | <p>Perform these steps:</p> <ol style="list-style-type: none"> 1. Go to the Control Panel on the Start menu, and double-click Administrative Tools. 2. Select Computer Management > Device Manager > System Devices. 3. Look for the LSI-supported DSM. The name ends with the text Device-Specific Module for Multi-Path. If it is present, DSM is installed. |
| <p>What is the default vendor ID string and the product ID string?</p> | <p>By default, the vendor ID string and the product ID string configured for LSI storage arrays are named LSI/INF-01-00. If not, the PnP manager cannot choose the failover driver to manage the volume. The failover driver takes over, which causes delays. If you suspect that this event has occurred, check the non-user configuration region of the controller firmware</p> |
| <p>What should I do if I receive this message? Warning: Changing the storage array name can cause host applications to lose access to the storage array if the host is running certain path failover drivers. If any of your hosts are running path failover drivers, please update the storage array name in your path failover driver's configuration file before rebooting the host machine to insure uninterrupted access to the storage array. Refer to your path failover driver documentation for more details.</p> | <p>You do not need to update files. The information is dynamically created only when the storage array is found initially. Use one of these two options to correct this behavior:</p> <ul style="list-style-type: none"> ▪ Restart the host server. ▪ Unplug the storage array from the host server, and perform a rescan of all of the devices. After the devices have been removed from the storage array, you can re-attach them. Another rescan takes place, which rebuilds the information with the updated names. |

Installing or Upgrading SANtricity ES and DSM on the Windows OS

 **IMPORTANT** For SANtricity ES Storage Manager Version 10.80 on the Windows OS, only the Microsoft Multipath I/O (MPIO) Device Specific Module (DSM) failover driver is supported. You cannot install the DSM driver and the RDAC driver on the same system at the same time.

Perform the steps in this task to install the SANtricity ES Storage Manager and DSM or to upgrade from an earlier release of SANtricity ES Storage Manager and DSM on a system with a Windows OS. For a clustered system, perform these steps on each node of the system, one node at a time.

1. Open the installation program on the SANtricity ES Storage Manager Installation DVD.

The SANtricity ES Storage Manager installation window appears.

2. Click **Next**.
3. Accept the terms of the license agreement, and click **Next**.
4. Select **Custom**, and click **Next**.
5. Select the applications that you want to install.
 - a. Click the name of an application to see its description.
 - b. Select the check box next to an application to install it.
6. Click **Next**.

If you have a previous version of the software installed, you will receive a warning message:

```
Existing versions of the following software already reside on
this computer ... If you choose to continue, the existing
versions will be overwritten with new versions ....
```

7. If you receive this warning and want to update to SANtricity ES Storage Manager Version 10.80, click **OK**.
8. Select whether to automatically start the Event Monitor. Click **Next**.
 - Start the Event Monitor for the one I/O host on which you want to receive alert notifications.
 - Do not start the Event Monitor for all other I/O hosts attached to the storage array or for computers that you use to manage the storage array.
9. Click **Next**.
10. If you receive a warning about antivirus or backup software that is installed, click **Continue**.
11. Read the pre-installation summary, and click **Install**.
12. Wait for installation to complete, and click **Done**.

Removing SANtricity ES Storage Manager and the DSM Failover Driver from the Windows OS



IMPORTANT To prevent loss of data, the host from which you are removing SANtricity ES Storage Manager and the DSM must have only one path to the storage array. Reconfigure the connections between the host and the storage array to remove any redundant connections before you uninstall SANtricity ES Storage Manager and the DSM failover driver.

1. From the Windows **Start** menu, select **Control Panel**.

The **Control Panel** window appears.
2. In the **Control Panel** window, double-click **Add or Remove Programs**.

The **Add or Remove Programs** window appears.
3. Select **SANtricity ES Storage Manager**.
4. Click the **Remove** button to the right of the **SANtricity ES Storage Manager** entry.

WinObj

You can use WinObj to view the Object Manager namespace that is maintained by the OS. Every Windows OS driver that creates objects in the system can associate a name with the object that can be viewed from WinObj. With WinObj, you can view the volumes and paths that the host bus adapters (HBAs) have identified. You can also view what the failover driver identifies from a storage array.

Failover Drivers for the Linux Operating System

Redundant Dual Active Controller (RDAC) is the supported failover driver for SANtricity ES Storage Manager with Linux OSs.

Linux OS Restrictions

This version of the Linux OS RDAC failover driver does not support any Linux OS 2.4 kernels, such as the following:

- SUSE SLES 8 OS
- Red Hat 3 Linux OS
- SLES 8 and Red Hat 3 Linux OSs on POWER (LoP) servers

The Linux OS RDAC driver cannot coexist with a Fibre Channel host bus adapter (HBA)-level multi-path failover or failback driver, such as these:

- The 8.00.00-fo or 8.00.02-fo Linux OS device driver for the IBM DS4000 fc2-133 HBAs driver on servers with Intel architecture processors or AMD architecture processors
- The QLA driver for the Fibre Channel expansion adapters on the IBM LoP blade servers

You might have to modify the makefile of the HBA driver for it to be compiled in the non-failover mode.

Auto-Volume Transfer (AVT) mode is automatically enabled in the SANshare Storage Partitioning host type in the Linux OS. This mode causes contention when the RDAC failover driver is installed, so you must disable it before you install RDAC. Also a separate Linux OS host type exists in which AVT is already disabled.

When the RDAC failover driver detects that all paths to a storage array have failed, it reports I/O failure immediately. This behavior is different from the behavior of the failover device driver from IBM for the Fibre Channel HBA. The Fibre Channel HBA failover device driver waits for a certain timeout or retry period before reporting an I/O failure to the host application.

The cluster support feature in the Linux OS RDAC failover driver is only available for controller firmware version 5.4x.xx.xx or later. If a SCSI-2 reserve command or a SCSI-2 release command is addressed to a volume on a storage array that runs a firmware version earlier than 5.40, a check condition is returned.

LoP servers do not support clustering with this Linux OS RDAC failover driver.

For LoP servers, the `modprobe` command is not supported with this Linux OS RDAC failover driver release on the SUSE SLES 9 OS when the Linux OS RDAC failover driver is installed. Use the `insmod` command to remove and recover the device driver stack. On LoP pSeries servers with more than three processors, if you use the `modprobe` command, it might result in a hung server or panics.

Do not assign a universal access volume to LUN ID 0, especially with the RDAC failover driver installed. If you place a universal access volume at LUN ID 0, it might lead to loss of volume recognition of next sequence LUN IDs or a partial list of virtual volumes reported with the RDAC failover driver. Assign these volumes to LUN ID 31.

For LoP servers, the HBA hot-swap procedure to remove a live, fully functioning Fibre Channel HBA causes a system panic if the I/O is not diverted from that path first. This functionality is only supported on current 2.6 kernel versions. The work-around is to pull the Fibre Channel cable first, wait two minutes to five minutes for failover to complete, and then run the `drslot_chrp_pci -r -s slot-number` command.

The Linux OS includes a new method of kernel dump (kdump/kexec) to replace the previous LKCD (Linux Kernel Crash Dump) method for the SUSE OS and diskdump method for RHEL. If kdump is configured, kdump and kexec work together to capture kernel exceptions, save the kernel state/memory, and start a second kernel image for debugging the troubled kernel. The second kernel is called kdump kernel. Kexec and kdump are useful for troubleshooting panic conditions. With the current installation and driver build method, the RDAC failover driver modules are not included in the kdump kernel initrd image. An initrd image contains all necessary device driver modules that are used after the kernel image is loaded and before user space initialization is started. Because the RDAC failover driver modules are not included in the kdump initrd image, a user experiences these problems when kdump is configured: long boot times and the inability to save vmcore file in a SAN boot configuration. The RDAC failover driver installation builds a kdump kernel initrd image with the RDAC failover driver modules inside. Also, when the RDAC failover driver is installed, it detects that a kdump kernel is configured, and updates the initrd image with the RDAC failover drivers.

Unique Features of RDAC from LSI

Redundant Dual Active Controller (RDAC) is the failover driver for the Linux OS that is included in SANtricity ES Storage Manager. The RDAC failover driver includes these unique features:

- On-the-fly path validation.
- Cluster support.
- Automatic detection of path failure. The RDAC failover driver automatically routes I/O to another path in the same controller or to an alternate controller, in case all paths to a particular controller fail.
- Retry handling is improved, because the RDAC driver can better understand the controller-returned sense key/ASC/ASCQ of vendor-specific statuses of LSI.
- Automatic rebalance is handled. When the failed controller obtains Optimal status, storage array rebalance is performed automatically without user intervention.
- Three load-balancing policies are supported: round robin subset, least queue depth, and path weight.

Configuration Settings for Windows DSM and Linux RDAC

This topic applies to both the Windows OS and the Linux OS. The failover driver that is provided with the storage management software contains configuration settings that can modify the behavior of the driver.

- For the Linux OS, the configuration settings are in the `/etc/mpp.conf` file.
- For the Windows OS, the configuration settings are in the `HKEY_LOCAL_MACHINE\System\CurrentControlSet\Services\<DSM_Driver>\Parameters` registry key, where *<DSM_Driver>* is the name of the OEM-specific driver.

The default driver is `mppdsm.sys`. Any changes to the settings take effect on the next reboot of the host.

The default values listed in the following table apply to both the Windows OS and the Linux OS unless the OS is specified in parentheses. Many of these values are overridden by the failover installer for the Linux OS or the Windows OS.



ATTENTION Possible loss of data access – If you change these settings from their configured values, you might lose access to the storage array.

Configuration Settings for the Windows DSM and the Linux RDAC

| Parmeter Name | Default Value (Operating System) | Description |
|-----------------------|----------------------------------|--|
| MaxPathsPerController | 4 | The maximum number of paths (logical endpoints) that are supported per controller. The total number of paths to the storage array is the MaxPathsPerController value multiplied by the number of controllers. The allowed values range from 0x1 (1) to 0x20 (32) for the Windows OS, and from 0x1 (1) to 0xFF (255) for the Linux RDAC. For use by Customer and Technical Support representatives only. |
| ScanInterval | 1 (Windows) 60 (Linux) | The interval time, in seconds, that the failover driver checks for these conditions: <ul style="list-style-type: none"> A change in preferred ownership for a LUN An attempt to rebalance LUNs to their preferred paths A change in AVT enabled status or disabled status For the Windows OSs, the allowed values range from 0x1 to 0xFFFFFFFF and must be specified in minutes. For the Linux OSs, the allowed values range from 0x1 to 0xFFFFFFFF and must be specified in seconds. For use by Customer and Technical Support representatives only. |
| ErrorLevel | 3 | This setting determines which errors to log. These values are valid: <ul style="list-style-type: none"> 0 – Display all errors 1 – Display path failover errors, controller failover errors, retryable errors, fatal errors, and recovered errors 2 – Display path failover errors, controller failover errors, retryable errors, and fatal errors 3 – Display path failover errors, controller failover errors, and fatal errors 4 – Display controller failover errors, and fatal errors |

| Parmeter Name | Default Value (Operating System) | Description |
|----------------------------|----------------------------------|--|
| | | For use by Customer and Technical Support representatives only. |
| SelectionTimeoutRetryCount | 0 | <p>The number of times a selection timeout is retried for an I/O request before the path fails. If another path to the same controller exists, the I/O is retried. If no other path to the same controller exists, a failover takes place. If no valid paths exist to the alternate controller, the I/O is failed.</p> <p>The allowed values range from 0x0 to 0xFFFFFFFF.</p> <p>For use by Customer and Technical Support representatives only.</p> |
| CommandTimeoutRetryCount | 1 | <p>The number of times a command timeout is retried for an I/O request before the path fails. If another path to the same controller exists, the I/O is retried. If another path to the same controller does not exist, a failover takes place. If no valid paths exist to the alternate controller, the I/O is failed.</p> <p>The allowed values range from 0x0 to 0xa (10) for the Windows OS, and from 0x0 to 0xFFFFFFFF For the Linux RDAC.</p> <p>For use by Customer and Technical Support representatives only.</p> |
| UaRetryCount | 10 | <p>The number of times a Unit Attention (UA) status from a LUN is retried. This parameter does not apply to UA conditions due to Quiescence In Progress.</p> <p>The allowed values range from 0x0 to 0x64 (100) for the Windows OS, and from 0x0 to 0xFFFFFFFF For the Linux RDAC.</p> <p>For use by Customer and Technical Support representatives only.</p> |
| SynchTimeout | 120 | <p>The timeout, in seconds, for synchronous I/O requests that are generated internally by the failover driver. Examples of internal requests include those related to rebalancing, path validation, and issuing of failover commands.</p> <p>The allowed values range from 0x1 to 0xFFFFFFFF.</p> <p>For use by Customer and Technical Support representatives only.</p> |

| Parmeter Name | Default Value (Operating System) | Description |
|---------------------|----------------------------------|--|
| DisableLunRebalance | 0 | <p>This parameter provides control over the LUN failback behavior of rebalancing LUNs to their preferred paths. These values are possible:</p> <ul style="list-style-type: none"> ▪ 0 – LUN rebalance is enabled for both AVT and non-AVT modes. ▪ 1 – LUN rebalance is disabled for AVT mode and enabled for non-AVT mode. ▪ 2 – LUN rebalance is enabled for AVT mode and disabled for non-AVT mode. ▪ 3 – LUN rebalance is disabled for both AVT and non-AVT modes. ▪ 4 – The selective LUN Transfer feature is enabled if AVT mode is off and <code>ClassicModeFailover</code> is set to LUN level 1. |
| S2ToS3Key | Unique key | <p>This value is the SCSI-3 reservation key generated during failover driver installation.</p> <hr/> <p>NOTE For use by Customer and Technical Support representatives only.</p> <hr/> |
| LoadBalancePolicy | 1 | <p>This parameter determines the load-balancing policy used by all volumes managed by the Windows DSM and Linux RDAC failover drivers. These values are valid:</p> <ul style="list-style-type: none"> ▪ 0 – Round robin with subset. ▪ 1 – Least queue depth with subset. ▪ 2 – Least path weight with subset (Windows OS only). |
| ClassicModeFailover | 0 | <p>This parameter provides control over how the DSM handles failover situations. These values are valid:</p> <ul style="list-style-type: none"> ▪ 0 – Perform controller-level failover (all LUNs are moved to the alternate controller). ▪ 1 – Perform LUN-level failover (only the LUNs indicating errors are transferred to the alternate controller). |

| Parameter Name | Default Value (Operating System) | Description |
|--------------------------------------|----------------------------------|--|
| SelectiveTransferMaxTransferAttempts | 3 | This parameter sets the maximum number of times that a host transfers the ownership of a LUN to the alternate controller when the Selective LUN Transfer mode is enabled. This setting prevents multiple hosts from continually transferring LUNs between controllers. |
| SelectiveTransferMinIOWaitTime | 5 | This parameter sets the minimum wait time (in seconds) that the DSM waits before it transfers a LUN to the alternate controller when the Selective LUN Transfer mode is enabled. This parameter tries to stop excessive LUN transfers due to intermittent link errors. |

Prerequisites for Installing RDAC on the Linux OS

Before installing RDAC on the Linux OS, make sure that your storage array meets these conditions:

- Make sure that the host system on which you want to install the RDAC driver has supported HBAs.
- Refer to the installation electronic document topics for your controller tray or controller-drive tray for any configuration settings that you need to make.
- Although the system can have Fibre Channel HBAs from multiple vendors or multiple models of Fibre Channel HBAs from the same vendor, you can connect only the same model of Fibre Channel HBAs to each storage array.
- Make sure that the low-level HBA driver has been correctly built and installed before RDAC driver installation.
- The standard HBA driver must be loaded before you install the RDAC driver. The HBA driver has to be a non-failover driver.
- For LSI HBAs, the port driver is named `mptbase`, and the host driver is named `mptscsi` or `mptscsih`, although the name depends on the driver version. The Fibre Channel driver is named `mptfc`, the SAS driver is named `mptsas`, and the SAS2 driver is named `mpt2sas`.
- For QLogic HBAs, the base driver is named `qla2xxx`, and host driver is named `qla2300`. The 4-GB HBA driver is named `qla2400`.
- For IBM Emulex HBAs, the base driver is named `lpfcdd` or `lpfc`, although the name depends on the driver version.
- For Emulex HBAs, the base driver is named `lpfcdd` or `lpfc`, although the name depends on the driver version.
- Make sure that the kernel source tree for the kernel version to be built against is already installed. You must install the kernel source rpm on the target system for the SUSE SLES OS. You are not required to install the kernel source for the Red Hat OS.
- Make sure that the necessary kernel packages are installed: `source rpm` for the SUSE OS and `kernel headers/kernel-devel` for the Red Hat Enterprise Linux OS.

In SUSE OSs, you must include these items for the HBAs mentioned as follows:

- For LSI HBAs, INITRD_MODULES includes `mptbase` and `mptscsi` (or `mptscsih`) in the `/etc/sysconfig/kernel` file. The Fibre Channel driver is named `mptfc`, the SAS driver is named `mptsas`, and the SAS2 driver is named `mpt2sas`.
- For QLogic HBAs, INITRD_MODULES includes a `qla2xxx` driver and a `qla2300` driver in the `/etc/sysconfig/kernel` file.
- For IBM Emulex HBAs, INITRD_MODULES includes an `lpfcdd` driver or an `lpfc` driver in the `/etc/sysconfig/kernel` file.
- For Emulex HBAs, INITRD_MODULES includes an `lpfcdd` driver or an `lpfc` driver in the `/etc/sysconfig/kernel` file.

Installing SANtricity ES Storage Manager and RDAC on the Linux OS



IMPORTANT SANtricity ES Storage Manager requires that the different Linux OS kernels have separate installation packages. Make sure that you are using the correct installation package for your particular Linux OS kernel.

1. Open the installation program on the SANtricity ES Storage Manager Installation DVD.
The SANtricity ES Storage Manager installation window appears.
2. Click **Next**.
3. Accept the terms of the license agreement, and click **Next**.
4. Select one of the installation packages:
 - **Typical** – Select this option to install all of the available host software.
 - **Management Station** – Select this option to install software to configure, manage, and monitor a storage array. This option does not include RDAC. This option only installs the client software.
 - **Host** – Select this option to install the storage array server software.
 - **Custom** – Select this option to customize the features to be installed.



NOTE For this procedure, **Typical** is selected. If the **Host** installation option is selected, the Agent, the Utilities, and the RDAC driver will be installed.

You might receive a warning after you click **Next**. The warning states:

```
Existing versions of the following software already reside on
this computer ... If you choose to continue, the existing
versions will be overwritten with new versions ....
```

If you receive this warning and want to update to SANtricity ES Storage Manager Version 10.80, click **OK**.

5. Click **Install**.
You will receive a warning after you click **Install**. The warning tells you that the RDAC driver is not automatically installed. You must manually install the RDAC driver.
The RDAC source code is copied to the specified directory in the warning message. Go to that directory, and perform the steps in [Installing RDAC Manually on the Linux OS](#).
6. Click **Done**.

Installing RDAC Manually on the Linux OS

1. To unzip the RDAC `tar.gz` file and untar the RDAC tar file, type this command, and press **Enter**:

```
tar -zxvf <filename>
```

2. Go to the Linux RDAC directory.
3. Type this command, and press **Enter**.

```
make uninstall
```

4. To remove the old driver modules in that directory, type this command, and press **Enter**:

```
make clean
```

5. To compile all driver modules and utilities in a multiple CPU server (SMP kernel), type this command, and press **Enter**:

```
make
```

6. Type this command, and press **Enter**:

```
make install
```

These actions result from running this command:

- The driver modules are copied to the kernel module tree.
 - The new RAMdisk image (`mpp-`uname -r`.img`) is built, which includes the RDAC driver modules and all driver modules that are needed at boot.
7. Follow the instructions shown at the end of the build process to add a new boot menu option that uses `/boot/mpp-`uname -r`.img` as the initial RAMdisk image.

Making Sure that RDAC Is Installed Correctly on the Linux OS

1. Restart the system by using the new boot menu option.
2. Make sure that these driver stacks were loaded after restart:

- `scsi_mod`
- `sd_mod`
- `sg`
- `mppUpper`
- The physical HBA driver module
- `mppVhba`

3. Type this command, and press **Enter**:

```
/sbin/lsmode
```

4. To make sure that the RDAC driver discovered the available physical volumes and created virtual volumes for them, type this command, and press **Enter**:

```
/opt/mpp/lsvdev
```

You can now send I/O to the volumes.

5. If you make any changes to the RDAC configuration file (`/etc/mpp.conf`) or the persistent binding file (`/var/mpp/devicemapping`), run the `mppUpdate` command to rebuild the RAMdisk image to include the new file. In this way, the new configuration file (or persistent binding file) can be used on the next system restart.

6. To dynamically reload the driver stack (`mppUpper`, physical HBA driver modules, `mppVhba`) without restarting the system, perform these steps:
 - a. To unload the `mppVhba` driver, type this command, and press **Enter**:

```
rmmod mppVhba
```
 - b. To unload the physical HBA driver, type this command, and press **Enter**:

```
modprobe -r "physical hba driver modules"
```
 - c. To unload the `mppUpper` driver, type this command, and press **Enter**:

```
rmmod mppUpper
```
 - d. To reload the `mppUpper` driver, type this command, and press **Enter**:

```
modprobe mppUpper
```
 - e. To reload the physical HBA driver, type this command, and press **Enter**:

```
modprobe "physical hba driver modules"
```
 - f. To reload the `mppVhba` driver, type this command, and press **Enter**:

```
modprobe mppVhba
```
7. Restart the system whenever there is an occasion to unload the driver stack.



IMPORTANT Using the `modprobe` command with the RDAC driver stack or using the `rmmod` command to remove all the drivers in the RDAC driver stack, in order, is not recommended nor supported.

8. Disable Auto-Volume Transfer (AVT) by issuing a set controller command line interface (CLI) command. For example, to disable AVT for host region 6 and controller A, use this command:

```
set controller[a] hostNVSRAMByte[0x6, 0x24]=0x00;
```
9. Use a utility, such as `devlabel`, to create user-defined device names that can map devices based on a unique identifier, called a UUID.
10. Use the `udev` command for persistent device names. The `udev` command dynamically generates device name links in the `/dev/disk` directory based on path, ID or UUID.

```
linux-kbx5:/dev/disk # ls /dev/disk by-id by-path by-uuid
```

For example, the `/dev/disk/by-id` directory links volumes that are identified by WWIDs of the volumes to actual disk device nodes.

```
lrwxrwxrwx 1 root root 10 Feb 23 12:15
scsi-3600a0b80000c2df9000003b141417799 -> ../../sdda
```

```
lrwxrwxrwx 1 root root 9 Feb 23 12:15
scsi-3600a0b80000f27030000000d416b94fd -> ../../sdc
```

```
lrwxrwxrwx 1 root root 9 Feb 23 12:15
scsi-3600a0b80000f270300000015416b958f -> ../../sdg
```

Configuring Failover Drivers for the Linux OS

The Windows OS and the Linux OS share the same set of tunable parameters to enforce the same I/O behaviors. For a description of these parameters, go to [Configuration Settings for Windows DSM and Linux RDAC](#).

Configuration Settings for Failover Drivers for the Linux OS

| Parameter Name | Default Value | Description |
|------------------------|---------------|--|
| ImmediateVirtLunCreate | 0 | This parameter determines whether to create the virtual LUN immediately if the owning physical path is not yet discovered. This parameter can take the following values: <ul style="list-style-type: none"> 0 – Do not create the virtual LUN immediately if the owning physical path is not yet discovered. 1 – Create the virtual LUN immediately if the owning physical path is not yet discovered. |
| BusResetTimeout | | The time, in seconds, for the RDAC driver to delay before retrying an I/O operation if the DID_RESET status is received from the physical HBA. A typical setting is 150. |
| AllowHBAsgDevs | 0 | This parameter determines whether to create individual SCSI generic (SG) devices for each I:T:L for the end LUN through the physical HBA. This parameter can take the following values: <ul style="list-style-type: none"> 0 – Do not allow creation of SG devices for each I:T:L through the physical HBA. 1 – Allow creation of SG devices for each I:T:L through the physical HBA. |

Compatibility and Migration

Controller firmware – The Linux OS RDAC driver is compatible with the controller firmware. However, the Linux OS RDAC driver does not support SCSI-2 to SCSI-3 reservation translation unless the release is version 8.40.xx or later.

Linux OS distributions – The Linux OS RDAC driver is intended to work on any Linux OS distribution that has the standard SCSI I/O storage array (SCSI middle-level and low-level interfaces). This release is targeted specifically at SUSE Linux OS Enterprise Server and Red Hat Advanced Server.

mppUtil Utility

The mppUtil utility is a general-purpose command-line driven utility that works only with MPP-based RDAC solutions. The utility instructs RDAC to perform various maintenance tasks but also serves as a troubleshooting tool when necessary.

To use the mppUtil utility, type this command, and press **Enter**:

```
mppUtil [-a target_name] [-c wwn_file_name] [-d debug_level]
[-e error_level] [-g virtual_target_id] [-I host_num]
[-o feature_action_name[=value][, SaveSettings]]
[-s "failback" | "avt" | "busscan" | "forcerebalance"] [-S] [-U]
[-V] [-w target_wwn,controller_index]
```



NOTE The quotation marks must surround the parameters.

The mppUtil utility is a cross-platform tool. Some parameters might not have a meaning in a particular OS environment. A description of each parameter follows.

mppUtil Parameters

| Parameter | Description |
|-------------------------------|---|
| <code>-a target_name</code> | Shows the RDAC driver's internal information for the specified virtual <i>target_name</i> (storage array name). If a <i>target_name</i> value is not included, the <code>-a</code> parameter shows information about all of the storage arrays that are currently detected by this host. |
| <code>-c wwn_file_name</code> | Clears the WWN file entries. This file is located at <code>/var/mpp</code> with the extension <code>.wwn</code> . |
| <code>-d debug_level</code> | <p>Sets the current debug reporting level. This option works only if the RDAC driver has been compiled with debugging enabled. Debug reporting is comprised of two segments. The first segment refers to a specific area of functionality, and the second segment refers to the level of reporting within that area. The <i>debug_level</i> is one of these hexadecimal numbers:</p> <ul style="list-style-type: none"> ▪ <code>0x20000000</code> – Shows messages from the RDAC driver's <code>init()</code> routine. ▪ <code>0x10000000</code> – Shows messages from the RDAC driver's <code>attach()</code> routine. ▪ <code>0x08000000</code> – Shows messages from the RDAC driver's <code>ioctl()</code> routine. ▪ <code>0x04000000</code> – Shows messages from the RDAC driver's <code>open()</code> routine. ▪ <code>0x02000000</code> – Shows messages from the RDAC driver's <code>read()</code> routine. ▪ <code>0x01000000</code> – Shows messages related to HBA commands. ▪ <code>0x00800000</code> – Shows messages related to aborted commands. ▪ <code>0x00400000</code> – Shows messages related to panic dumps. ▪ <code>0x00200000</code> – Shows messages related to synchronous I/O activity. ▪ <code>0x00000001</code> – Debug level 1. ▪ <code>0x00000002</code> – Debug level 2. ▪ <code>0x00000004</code> – Debug level 3. ▪ <code>0x00000008</code> – Debug level 4. <p>These options can be combined with the logical AND operator to provide multiple areas and levels of reporting as needed. For use by Customer and Technical Support representatives only.</p> |

| Parameter | Description |
|---|---|
| <code>-e <i>error_level</i></code> | <p>Sets the current error reporting level to <i>error_level</i>, which can have one of these values:</p> <ul style="list-style-type: none"> ▪ 0 – Show all errors. ▪ 1 – Show path failover, controller failover, retryable, fatal, and recovered errors. ▪ 2 – Show path failover, controller failover, retryable, and fatal errors. ▪ 3 – Show path failover, controller failover, and fatal errors. This is the default setting. ▪ 4 – Show controller failover and fatal errors. ▪ 5 – Show fatal errors. <p>For use by Customer and Technical Support representatives only.</p> |
| <code>-g <i>virtual_target_id</i></code> | <p>Display the RDAC driver's internal information for the specified <i>virtual_target_id</i>.</p> |
| <code>-I <i>host_num</i></code> | <p>Prints the maximum number of targets that can be handled by that host. Here, host refers to the HBA drivers on the system and includes the RDAC driver. The host number of the HBA driver is given as an argument. The host numbers assigned by the Linux middle layer start from 0. If two ports are on the HBA card, host numbers 0 and 1 would be taken up by the low-level HBA driver, and the RDAC driver would be at host number 2. Use <code>/proc/scsi</code> to determine the host number.</p> |
| <code>-o <i>feature_action_name</i>[=<i>value</i>] [, <i>SaveSettings</i>]</code> | <p>Troubleshoots a feature or changes a configuration setting. Without the <i>SaveSettings</i> keyword, the changes affect only the in-memory state of the variable. The <i>SaveSettings</i> keyword changes both the in-memory state and the persistent state. You must run <code>mppUpdate</code> to reflect these changes in the inird image before rebooting the server. Some example commands are:</p> <ul style="list-style-type: none"> ▪ <code>mppUtil -o</code> – Displays all the available feature action names. ▪ <code>mppUtil -o ErrorLevel=0x2</code> – Sets the <i>ErrorLevel</i> parameter to <code>0x2</code> (affects only the in-memory state). |
| <code>-s ["failback" "avt" "busscan" "forcerebalance"]</code> | <p>Manually initiates one of the RDAC driver's scan tasks.</p> <ul style="list-style-type: none"> ▪ A "failback" scan causes the RDAC driver to reattempt communications with any failed controllers. ▪ An "avt" scan causes the RDAC driver to check whether AVT has been enabled or disabled for an entire storage array. ▪ A "busscan" scan causes the RDAC driver to go through its unconfigured devices list to see if any of them have become configured. |

| Parameter | Description |
|---------------------------------------|---|
| | <ul style="list-style-type: none"> A “forcerebalance” scan causes the RDAC driver to move storage array volumes to their preferred controller and ignore the value of the <code>DisableLunRebalance</code> configuration parameter of the RDAC driver. |
| -S | Reports the Up state or the Down state of the controllers and paths for each LUN in real time. |
| -U | Refreshes the Universal Transport Mechanism (UTM) LUN information in MPP driver internal data structure for all the storage arrays that have already been discovered. |
| -V | Prints the version of the RDAC driver currently running on the system. |
| -w <i>target_wwn,controller_index</i> | For use by Customer and Technical Support representatives only. |

Frequently Asked Questions about Linux Failover Drivers

Frequently Asked Questions about Linux Failover Drivers

| Question | Answer |
|--|---|
| How do I get logs from RDAC in the Linux OS? | Use the <code>mppSupport</code> command to obtain several logs related to RDAC. The <code>mppSupport</code> command is found in the <code>/opt/mpp/mppSupport</code> directory. The command creates a file named <code>mppSupportdata_hostname_RDAC_version_datetime.tar.gz</code> in the <code>/tmp</code> directory. |
| How does persistent naming work? | The Linux OS SCSI device names can change when the host system restarts. Use a utility, such as <code>devlabel</code> , to create user-defined device names that will map devices based on a unique identifier. The <code>udev</code> method is the preferred method for the SLES 10 OS and the RHEL OS. |
| What must I do after applying a kernel update? | After you apply the kernel update and start the new kernel, perform these steps to build the RDAC Initial Ram Disk image (initrd image) for the new kernel: <ol style="list-style-type: none"> Change the directory to the Linux RDAC source code directory. Type <code>make uninstall</code>, and press Enter. Reinstall RDAC. |
| What is the Initial Ram Disk Image (initrd image), and how do I create a new initrd image? | The initrd image is automatically created when the driver is installed by using the <code>make install</code> command. The boot loader configuration file must have an entry for this newly created image. The initrd image is located in the boot partition. The file is named <code>mpp'-uname -r'.img</code> . |

| Question | Answer |
|--|--|
| | <p>For a driver update, if the system already has a previous entry for RDAC, the system administrator must modify the existing RDAC entry in the boot loader configuration file. In most of the cases, no change is required if the kernel version is the same.</p> <p>To create a new initrd image, type <code>mppUpdate</code>, and press Enter. The old image file is overwritten with the new image file.</p> <p>For the SUSE OS, if third-party drivers need to be added to the initrd image, change the <code>/etc/sysconfig/kernel</code> file with the third-party driver entries. Run the <code>mppUpdate</code> command again to create a new initrd image.</p> |
| How do I remove unmapped or disconnected devices from the existing host? | Run <code>hot_add -d</code> to remove all unmapped or disconnected devices. |
| What if I remap a LUN from the storage array? | Run <code>hot_add -u</code> to update the host with the changed LUN mapping. |
| What if I change the size of the LUN on the storage array? | Run <code>hot_add -c</code> to change the size of the LUN on the host. |
| How do I make sure that RDAC finds the available storage arrays? | <p>To make sure that the RDAC driver has found the available storage arrays and created virtual storage arrays for them, type these commands, and press Enter after each command.</p> <pre>ls -lR /proc/mpp mppUtil -a /opt/mpp/lsvdev</pre> <p>To show all attached and discovered volumes, type <code>cat /proc/scsi/scsi</code>, and press Enter.</p> |
| <p>What should I do if I receive this message?</p> <p>Warning: Changing the storage array name can cause host applications to lose access to the storage array if the host is running certain path failover drivers.</p> <p>If any of your hosts are running path failover drivers, please update the storage array name in your path failover driver's configuration file before rebooting the host machine to insure uninterrupted access to the storage array. Refer to your path failover driver documentation for more details.</p> | <p>The path failover drivers that cause this warning are the RDAC drivers on both the Linux OS and the Windows OS.</p> <p>The storage array user label is used for storage array-to-virtual target ID binding in the RDAC driver. For the Linux OS, change this file to add the storage array user label and its virtual target ID.</p> <pre>.~ # more /var/mpp/devicemapping</pre> |

Device Mapper Features

- Provides a single block device node for a multipathed logical unit
- Ensures that I/O is re-routed to available paths during a path failure
- Ensures that the failed paths are revalidated as soon as possible
- Configures the multipaths to maximize performance
- Reconfigures the multipaths automatically when events occur
- Provides DMMP features support to newly added logical unit
- Provides device name persistency for DMMP devices under `/dev/mapper/`
- Configures multipaths automatically at an early stage of rebooting to permit the OS to install and reboot on a multipathed logical unit

Device Mapper Features

- Provides a single block device node for a multipathed logical unit
- Ensures that I/O is re-routed to available paths during a path failure
- Ensures that the failed paths are revalidated as soon as possible
- Configures the multipaths to maximize performance
- Reconfigures the multipaths automatically when events occur
- Provides DMMP features support to newly added logical unit
- Provides device name persistency for DMMP devices under `/dev/mapper/`
- Configures multipaths automatically at an early stage of rebooting to permit the OS to install and reboot on a multipathed logical unit

Known Limitations and Issues of the Device Mapper

- When storage is configured with AVT mode, delays in device discovery might occur. Delays in device discovery might result in long delays when the operating system boots.
- In certain error conditions with `no_path_retry` or `queue_if_no_path` feature set, applications might hang forever. To overcome these conditions, you must enter the following command to all the affected multipath devices: `dmsetup message device 0 "fail_if_no_path"`, where `device` is the multipath device name (for example, `mpath2`; do not specify the path).
- An I/O hang might occur when a volume is unmapped without first deleting the Device Mapper.
- If the `scsi_dh_rdac` module is not included in `initrd`, slower device discovery might occur, and the `syslog` might get populated with buffer I/O error messages.
- Use of the DMMP and RDAC failover solutions together on the same host is not supported. Use only one solution at a time.

Setting Up the multipath.conf File

The `multipath.conf` file is the configuration file for the multipath daemon, `multipathd`. The `multipath.conf` file overwrites the built-in configuration table for `multipathd`. Any line in the file whose first non-white-space character is `#` is considered a comment line. Empty lines are ignored.

Installing Device Mapper Multi-Path for the SLES 11.1 OS

All of the components required for Device Mapper Multi-Path (DMMP) are included in SUSE Linux Enterprise Server (SLES) Version 11.1 installation media. However, you might need to select the specific component based on the storage hardware type. By default, DMMP is disabled in the SLES OS. Follow these steps to install and enable DMMP.

1. On the command line, type `chkconfig multipath on`.
The `multipathd` daemon is enabled when the system starts again.
2. Edit the `/etc/sysconfig/kernel` file to add the directive `scsi_dh_rdac` to the `INITRD_MODULES` section of the file
3. Run the following command to create a new `initrd` image by adding `scsi_dh_rdac` in ram disk:
`mkinitrd -i /boot/initrd-r -k /boot/vmlinuz`
4. Update the boot loader to point to the new `initrd` image.
5. Reboot the host with the new `initrd` image.

Configuring Device Mapper Multi-Path for the SLES 11.1 OS

To configure DMMP, perform these steps:

1. At the command prompt, run the following command to copy and rename the `/usr/share/doc/packages/multipath-tools/multipath.conf.synthetic` file to `/etc/multipath.conf`:
`cp /usr/share/doc/packages/multipath-tools/multipath.conf.synthetic /etc/multipath.conf`
2. At the command prompt, type the following command to edit the `/etc/multipath.conf` file to use the same values as the LSI device below:

```
cp /usr/share/doc/packages/multipath-tools/multipath.conf.synthetic /etc/multipath.conf

#####

## This is a template multipath-tools configuration file
## Uncomment the lines relevant to your environment
##
defaults {
    udev_dir                /dev
    polling_interval        5
    selector                "round-robin 0"
    path_grouping_policy    multibus
    getuid_callout          "/lib/udev/scsi_id -g -u -d /dev/%n"
    prio                    const
    path_checker            directio
    rr_min_io               100
    max_fds                  8192
    rr_weight                priorities
}
```

```

failback                                immediate
no_path_retry                            fail
user_friendly_names                      no
}
blacklist {
devnode  "^(ram|raw|loop|fd|md|dm-|sr|scd|st)[0-9]*"
devnode  "^hd[a-z][[0-9]*]"
devnode  "^cciss!c[0-9]d[0-9]*[p[0-9]*]"
device {
    vendor "*"
    product "Universal Xport"
}
}
#blacklist_exceptions {
#    devnode  "^dasd[c-d]+[0-9]*"
#    wwid"IBM.75000000092461.4d00.34"
#}
#multipaths {
#    multipath {
#        wwid                3600508b4000156d700012000000b0000
#        alias                yellow
#        path_grouping_policy multibus
#        path_checker          directio
#        path_selector         "round-robin 0"
#        failback              manual
#        rr_weight              priorities
#        no_path_retry         5
#        rr_min_io             100
#    }
#    multipath {
#        wwid                1DEC_____321816758474
#        alias                red
#    }
#}
devices {
    device {
        vendor                "LSI"
        product                "INF-01-00"
        path_grouping_policy   group_by_prio
        prio                   rdac
        getuid_callout         "/lib/udev/scsi_id -g -u -d /dev/%n"
        path_checker           rdac
        path_selector          "round-robin 0"
        hardware_handler       "1 rdac"
        failback                immediate
        rr_weight               priorities
        no_path_retry          30
        rr_min_io              100
    }
}
#####

```

- At the command prompt, run the following command to enable the multipathd daemon to start during boot time:

```
chkconfig multipathd on
```

4. Edit the `/etc/sysconfig/kernel` file to add the directive `"scsi_dh_rdac"` to the `NITRD_MODULES` section of the file.
5. At the command prompt, run the following command to create a new `initrd` image file that includes the `"scsi_dh_rdac"`:

```
mkinitrd -k /boot/vmlinuz-$(uname -r) -i /boot/initrd-$(uname -r)-scsi_dh -M /boot/System.map-$(uname -r)
```
6. Modify the boot loader to use the new `initrd` file created in step 5.
7. Reboot the SUSE 11.1 host.

Verifying that Device Mapper Multi-Path for the SLES 11.1 OS is Installed Correctly

To verify that Device Mapper (DMMP) is installed correctly, perform these steps:

1. At the command prompt, run the `rpm -qa |grep device-mapper` command to verify that DMMP is installed correctly.
2. At the command prompt, run the `rpm -qa |grep multipath-tools` command to verify that multipath tools package version 0.4.8-40.6.1 or later is installed.

Copy and Rename the Sample File

Copy and rename the sample file located at `/usr/share/doc/packages/multipath-tools/multipath.conf.synthetic` to `/etc/multipath.conf`. Configuration changes are now accomplished by editing the new `/etc/multipath.conf` file. All entries for multipath devices are commented out initially. The configuration file is divided into five sections:

- **defaults** – Specifies all default values.
- **blacklist** – All devices are blacklisted for new installations. The default blacklist is listed in the commented-out section of the `/etc/multipath.conf` file. Blacklist the device mapper multipath by WWID if you do not want to use this functionality.
- **blacklist_exceptions** – Specifies any exceptions to the items specified in the section `blacklist`.
- **devices** – Lists all multipath devices with their matching vendor and product values.
- **multipaths** – Lists the multipath device with their matching WWID values.

Determine the Attributes of a Multipath Device

To determine the attributes of a multipath device, check the `multipaths` section of the `/etc/multipath.conf` file, then the `devices` section, then the `defaults` section. The model settings used for multipath devices are listed for each storage array and include matching vendor and product values. Add matching storage vendor and product values for each type of volume used in your storage array.

For each UTM LUN mapped to the host, include an entry in the `blacklist` section of the `/etc/multipath.conf` file. The entries should follow the pattern of the following example.

```
blacklist {
device {
    vendor "*"
    product "Universal Xport"
}
}
```

The following example shows the devices section for LSI storage from the sample `/etc/multipath.conf` file. Update the vendor ID, which is LSI in the sample file, and the product ID, which is INF-01-00 in the sample file, to match the equipment in the storage array.

```
devices {
  device {
    vendor          "LSI"
    product         "INF-01-00"
    path_grouping_policy group_by_prio
    prio           rdac
    getuid_callout  "/lib/udev/scsi_id -g -u -d /dev/%n"
    polling_interval 5
    path_checker    rdac
    path_selector   "round-robin 0"
    hardware_handler "1 rdac"
    failback        immediate
    features        "2 pg_init_retries 50"
    no_path_retry   30
    rr_min_io       100
  }
}
```

The following table explains the attributes and values in the devices section of the `/etc/multipath.conf` file.

Attributes and Values in the multipath.conf File

| Attribute | Parameter Value | Description |
|-----------------------------------|---|---|
| <code>path_grouping_policy</code> | <code>group_by_prio</code> | The path grouping policy to be applied to this specific vendor and product storage. |
| <code>prio</code> | <code>rdac</code> | The program and arguments to determine the path priority routine. The specified routine should return a numeric value specifying the relative priority of this path. Higher numbers have a higher priority. |
| <code>getuid_callout</code> | <code>"/lib/udev/scsi_id -g -u -d /dev/%n"</code> | The program and arguments to call out to obtain a unique path identifier. |
| <code>polling_interval</code> | <code>5</code> | The interval between two path checks, in seconds. |
| <code>path_checker</code> | <code>rdac</code> | The method used to determine the state of the path. |
| <code>path_selector</code> | <code>"round-robin 0"</code> | The path selector algorithm to use when there is more than one path in a path group. |
| <code>hardware_handler</code> | <code>"1 rdac"</code> | The hardware handler to use for handling device-specific knowledge. |
| <code>failback</code> | <code>10</code> | A parameter to tell the daemon how to manage path group failback. In this example, the parameter is set to 10 seconds, so failback occurs 10 seconds after a |

| Attribute | Parameter Value | Description |
|---------------|------------------------------|--|
| | | device comes online. To disable the failback, set this parameter to manual . Set it to immediate to force failback to occur immediately. |
| features | "2 pg_init_retries 50" | Features to be enabled. This parameter sets the kernel parameter <code>pg_init_retries</code> to 50. The <code>pg_init_retries</code> parameter is used to retry the mode select commands. |
| no_path_retry | 30 | Specify the number of retries before queuing is disabled. Set this parameter to fail for immediate failure (no queuing). When this parameter is set to queue , queuing continues indefinitely. |
| rr_min_io | 100 | The number of I/Os to route to a path before switching to the next path in the same path group. This setting applies if there is more than one path in a path group. |

Using the Device Mapper Devices

Multipath devices are created under `/dev/` directory with the prefix `dm-`. These devices are the same as any other block devices on the host. To list all of the multipath devices, run the `multipath -ll` command. The following example shows system output from the `multipath -ll` command for one of the multipath devices.

```
mpathp (3600a0b80005ab177000017544a8d6b92) dm-0 LSI,INF-01-00
[size=5.0G][features=3 queue_if_no_path
pg_init_retries 50][hwhandler=1 rdac][rw]
\_ round-robin 0 [prio=6][active] \_ 5:0:0:0
sdc 8:32 [active][ready] \_
round-robin 0 [prio=1][enabled] \_ 4:0:0:0 sdb 8:16
[active][ghost]
```

In this example, the multipath device node `sfor` this device are `/dev/mapper/mpathp` and `/dev/dm-0`. The following table lists some basic options and parameters for the `multipath` command.

Options and Parameters for the `multipath` Command

| Command | Description |
|-------------------------------|---|
| <code>multipath -h</code> | Prints usage information |
| <code>multipath -ll</code> | Shows the current multipath topology from all available information, such as the sysfs, the device mapper, and path checkers. |
| <code>multipath -f map</code> | Flushes the multipath device map specified by the <code>map</code> option, if the map is unused |
| <code>multipath -F</code> | Flushes all unused multipath device maps |

Troubleshooting the Device Mapper

Troubleshooting the Device Mapper

| Situation | Resolution |
|--|--|
| Is the multipath daemon, multipathd, running? | At the command prompt, enter the command: <code>/etc/init.d/multipathd status</code> . |
| Why are no devices listed when you run the <code>multipath -ll</code> command? | At the command prompt, enter the command: <code>#cat /proc/scsi/scsi</code> . The system output displays all of the devices that are already discovered. Verify that the <code>multipath.conf</code> file has been updated with proper settings. |

Failover Drivers for the Solaris Operating System

MPxIO is the supported failover driver for the Solaris operating system.

Solaris OS Restrictions

SANtricity ES Storage Manager no longer supports or includes RDAC for these Solaris OS:

- Solaris 10 OS
- Solaris 9 OS
- Solaris 8 OS



NOTE MPxIO is not included on the SANtricity ES Storage Manager Installation DVD.

Prerequisites for Installing MPxIO on the Solaris OS for the First Time

Perform these prerequisite tasks.

1. Install the hardware
2. Map the volumes.
3. Make sure that RDAC is not on the system, because you cannot run both RDAC and MPxIO.



IMPORTANT RDAC and MPxIO cannot run on the same system.

Prerequisites for Installing MPxIO on a Solaris OS that Previously Ran RDAC

Perform these prerequisite tasks:

1. Make sure that there are no major problems in the current RDAC.



ATTENTION Potential loss of data access – Some activities, such as adding and removing storage arrays, can lead to stale information in the RDAC module name file. These activities might also render data temporarily inaccessible.

2. To make sure that no leftover RDAC files exist, type this command, and press **Enter**:

```
ls -l /var/symsm/directory
```

3. To make sure that the RDAC directory does not exist, type this command, and press **Enter**:

```
ls -l /dev/rdisk/*s2 >>filename
```

4. Examine the `/etc/symsm/mnf` file.

Each currently connected storage array should be on one line. An example line is:

```
infiniti23/24~1T01610104~ 0 1 7~1T04110240~ 7~0~3~~c6t3d0~c4t2d7~
```

5. Make sure that there are no extra lines for disconnected storage arrays.
6. Make sure that two controllers are listed on each line. (The example shows c6t3 and c4t2.)

7. Make sure that these controllers are the correct controllers.
8. Make sure there are no identical cXtX combinations. For example, if you see c6t3d0 and c6t3d4, a problem exists.
9. Make sure that no major problems exist in the Solaris OS.

When you reset or power-cycle a controller, it might take up to three minutes to come fully ready. Older storage arrays might take longer. The default Solaris Not Ready retry timer is only 30 seconds long, so spurious controller failovers might result. Sun Microsystems has already increased the timer for LSI-branded storage arrays to two minutes.

10. Make sure that the VERITAS Volume Manager can handle the MPxIO upgrade.
11. Capture the current configuration by performing these steps:

- a. Save this file.

```
/etc/symsm/mmf
```

- b. Save this file.

```
/etc/raid/rdac_address
```

- c. Type this command, and press **Enter**:

```
ls -l /dev/rdsk/*s2 >>rdsk.save
```

- d. Type this command, and press **Enter**:

```
ls -l /dev/symsm/dev/rdsk/*s2 >>symsm.save
```

- e. Type this command, and press **Enter**:

```
lad -y >>lad.save
```

12. To remove RDAC, type this command, and press **Enter**:

```
pkgrm RDAC
```



IMPORTANT Do not restart the system at this time.

Installing MPxIO on the Solaris 9 OS

MPxIO is not included in the Solaris 9 OS. To install MPxIO on the Solaris 9 OS, perform these steps.

1. Download and install the *SAN 4.4x release Software/Firmware Upgrades and Documentation* from this website:

```
http://www.sun.com/storage/san/
```

2. Install recommended patches.
3. To enable MPxIO on the Solaris 9 OS, perform these steps:

- a. Open this file:

```
/kernel/drv/scsi_vhci.conf
```

- b. Change the last line in the script to this command:

```
mpxio-disable="no";
```



NOTE Make sure that "no" is enclosed in double quotation marks.

4. Disable MPxIO on any Fibre Channel drives, such as internal drives, that should not be MPxIO enabled. To disable MPxIO on specific drives, perform these steps:

- a. Open the Fibre Channel port driver configuration file:

```
/kernel/drv/qlc.conf
```

- b. Add a line similar to the following:

```
name="qlc" parent="/pci@8,600000" port=0 unit-address="2"
mpxio-disable="yes";
```



NOTE To find the correct parent and port numbers, look at the device entry for the internal drives, found in `/dev/dsk`.

5. To update vfstab and the dump configuration, type this command:

```
stmsboot -u
```

6. Reboot the system.

Enabling MPxIO on the Solaris 10 OS

MPxIO is included in the Solaris 10 OS. Therefore, MPxIO does not need to be installed; It only needs to be enabled.



NOTE MPxIO for iSCSI is enabled by default.

1. To enable MPxIO, run one of these commands:

- To enable FC drives, run the `stmsboot -D fp -ecommand`.
- To enable 3-GB SAS drives, run the `stmsboot -D mpt -ecommand`.
- To enable 6-GB SAS drives, run the `stmsboot -D mpt sas -ecommand`.

To disable MPxIO on specific drives, add a line similar to the following line to the `/kernel/drv/fp.conf` Fibre Channel port driver configuration file:

```
name="fp" parent="/pci@8,600000/SUNW,qlc@2" port=0
mpxio-disable="yes";
```

To find the correct parent and port numbers, look at the device entry for the internal drives, found in `/dev/dsk`

2. Run the `stmsboot -u` command to update vfstab and the dump configuration.
3. Reboot the system.

Configuring Failover Drivers for the Solaris OS

Use the default settings for all Solaris OS configurations.

Frequently Asked Questions about Solaris Failover Drivers

Frequently Asked Questions about Solaris Failover Drivers

| Question | Answer |
|---|---|
| Where can I find MPxIO-related files? | You can find MPxIO-related files in these directories: /etc/ /kernel/drv |
| Where can I find data files? | You can find data files in these directories: /etc/raid ==> /usr/lib/symsm /var/symsm /var/opt/SM |
| Where can I find the command line interface (CLI) files? | You can find CLI files in this directory: /usr/sbin |
| Where can I find the bin files? | You can find the bin files in these directories: etc/raid/bin ==> /usr/lib/symsm/bin /usr/sbin/symsm ==> /usr/lib/symsm/bin |
| Where can I find device files? | You can find device files in these directories: /dev/rdisk /dev/dsk |
| Where can I find the SANtricity ES Storage Manager files? | You can find the SANtricity ES Storage Manager files in these directories: /opt/SMgr /opt/StorageManager |
| How can I get a list of controllers and their volumes? | Use the <code>lad -y</code> command. The command uses LUN 0 to get the information and is located in the <code>/usr/lib/symsm/bin</code> directory. It can be reached through <code>/etc/raid/bin</code> . This command updates the <code>mnf</code> file. |
| Where can I get a list of storage arrays, their volumes, LUNs, WWPNs, preferred paths, and owning controller? | Use the <code>SMdevices</code> utility, which is located in the <code>/usr/bin</code> directory. You can run the <code>SMdevices</code> utility from any command prompt. |
| How can I see whether volumes have been added? | Use the <code>devfsadm</code> utility to scan the system. Then run the <code>mpathadm list lu</code> command to list all volumes and their paths. If you still cannot see any new volumes, either reboot the host and run the <code>mpathadm list lu</code> command again, or use the <code>SMdevices</code> utility. |
| What file holds the storage array identification information? | Go to the <code>/etc/[osa symsm]/mnf</code> directory. The <code>mnf</code> file identifies storage arrays in these ways: <ul style="list-style-type: none"> ▪ Lists their ASCII names ▪ Shows their controller serial numbers ▪ Indicates the current LUN distribution ▪ Lists controller system names |

| Question | Answer |
|--|--|
| | <ul style="list-style-type: none">▪ Lists the storage array numbers |
| Why might the rdriver fail to attach and what can I do about it? | <p>The rdriver might not attach when no entry exists in the <code>rdriver.conf</code> file to match the device, or whether <code>rdnexus</code> runs out of buses.</p> <p>If no physical devnode exists, then the following actions must occur:</p> <ul style="list-style-type: none">▪ The <code>sd.conf</code> file must specify LUNs explicitly.▪ The <code>ssd.conf</code> file with the <code>itmpt</code> HBA must specify LUNs explicitly.▪ With Sun driver stacks, underlying HBA drivers dynamically create devnodes for <code>ssd</code>. <p>You must restart the system with the <code>reconfigure</code> option after you update the <code>rdriver.conf</code> file.</p> <p>In the Solaris 9 OS, you can use the <code>update_drv</code> command whether the HBA driver supports it.</p> |
| How can I determine whether the resolution daemon is working? | <p>Type this command, and press Enter:</p> <pre>ps -ef grep rd</pre> |

Command Line Interface and Script Commands for Version 10.80

This document provides a complete listing of all of the commands and the syntax for those commands that you need to configure and maintain a storage array. Information about how to configure and maintain a storage array using a command line interface is in *Configuring and Maintaining a Storage Array using the Command Line Interface*

This document supports host software version 10.80 and firmware version 7.80.

Formatting the Commands

The command line interface (CLI) is a software application that provides a way to configure and monitor storage arrays. Using the CLI, you can run commands from an operating system prompt, such as the DOS `C:` prompt, a Linux operating system path, or a Solaris operating system path.

The CLI gives you direct access to a script engine that is a utility in the SANtricity ES Storage Manager software (also referred to as the storage management software). The script engine runs commands that configure and manage the storage arrays. The script engine reads the commands, or runs a script file, from the command line and performs the operations instructed by the commands.

The script commands configure and manage a storage array. The script commands are distinct from the CLI commands. You can enter individual script commands, or you can run a file of script commands. When you enter an individual script command, you embed the script command in a CLI command. When you run a file of script commands, you embed the file name in the CLI command.

Structure of a CLI Command

The CLI commands are in the form of a command wrapper and elements embedded into the wrapper. A CLI command consists of these elements:

- A command wrapper identified by the term `SMcli`
- The storage array identifier
- Terminals that define the operation to be performed
- Script commands

The CLI command wrapper is a shell that identifies storage array controllers, embeds operational terminals, embeds script commands, and passes these values to the script engine.

All CLI commands have the following structure:

```
SMcli storageArray terminal script-commands;
```

- `SMcli` invokes the command line interface.
- `storageArray` is the name or the IP address of the storage array.
- `terminal` are CLI values that define the environment and the purpose for the command.
- `script-commands` are one or more script commands or the name of a script file that contains script commands. (The script commands configure and manage the storage array.)

If you enter an incomplete or inaccurate `SMcli` string that does not have the correct syntax, parameter names, options, or terminals, the script engine returns usage information.

For definitions, syntax, and parameters for the script commands, refer to the *Command Line Interface and Script Commands for Version 10.77*.

Interactive Mode

If you enter `SMcli` and a storage array name but do not specify CLI parameters, script commands, or a script file, the command line interface runs in interactive mode. Interactive mode lets you run individual commands without prefixing the commands with `SMcli`.

In interactive mode, you can enter a single command, view the results, and enter the next command without typing the complete **SMcli** string. Interactive mode is useful for determining configuration errors and quickly testing configuration changes.

To end an interactive mode session, type the operating system-specific command for terminating a program, such as **Control-C** on the UNIX operating system or the Windows operating system. Typing the termination command (**Control-C**) while in interactive mode turns off interactive mode and returns operation of the command prompt to an input mode that requires you to type the complete **SMcli** string.

CLI Command Wrapper Syntax

General syntax forms of the CLI command wrappers are listed in this section. The general syntax forms show the terminals and the parameters that are used in each command wrapper. The conventions used in the CLI command wrapper syntax are listed in the following table.

| Convention | Definition |
|---------------------------|---|
| a b | Alternative ("a" or "b") |
| <i>italicized-words</i> | A terminal that needs user input to fulfill a parameter (a response to a variable) |
| [...] (square brackets) | Zero or one occurrence (square brackets are also used as a delimiter for some command parameters) |
| { ... } (curly braces) | Zero or more occurrences |
| (a b c) | Choose only one of the alternatives |
| bold | A terminal that needs a command parameter entered to start an action |

```
SMcli host-name-or-IP-address [host-name-or-IP-address]
[-c "command; {command2};"]
[-n storage-system-name | -w wwID]
[-o outputfile] [-p password] [-e ] [-S ] [-quick]
```

```
SMcli host-name-or-IP-address [hostname-or-IP-address]
[-fscriptfile]
[-nstorage-system-name | -wwwID]
[-ooutputfile] [-ppassword] [-e ] [-S ] [-quick]
```

```
SMcli (-n storage-system-name | -wwwID)
[-c "command; {command2};"]
[-ooutputfile] [-ppassword] [-e ] [-S ] [-quick]
```

```
SMcli (-nstorage-system-name -wwwID)
[-fscriptfile]
[-ooutputfile] [-ppassword] [-e ] [-S ] [-quick]
```

```
SMcli -aemail:email-address [host-name-or-IP-address1]
[host-name-or-IP-address2]
[-nstorage-system-name | -wwwID | -hhost-name]
[-Iinformation-to-include] [-qfrequency] [-S ]
```



```
SMcli -xemail:email-address [host-name-or-IP-address1
[host-name-or-IP-address2]]
[-nstorage-system-name | -wwwID | -hhost-name] [-S]
```

```
SMcli (-a | -x) trap:community, host-name-or-IP-address
[host-name-or-IP-address1 [host-name-or-IP-address2]]
[-nstorage-system-name | -wwwID | -hhost-name] [-S]
```

```
SMcli -d [-w] [-i] [-s] [-v] [-S]
```

```
SMcli -mhost-name-or-IP-address-Femail-address
[-gcontactInfoFile] [-S]
```

```
SMcli -A [host-name-or-IP-address [host-name-or-IP-address]]
[-S]
```

```
SMcli -X (-nstorage-system-name | -wwwID | -hhost-name)
```

```
SMcli -?
```

Command Line Terminals

| Terminal | Definition |
|--------------------------------|---|
| <i>host-name-or-IP-address</i> | <p>Specifies either the host name or the Internet Protocol (IP) address (<i>xxx.xxx.xxx.xxx</i>) of an in-band managed storage array or an out-of-band managed storage array.</p> <ul style="list-style-type: none"> ▪ If you are managing a storage array by using a host through in-band storage management, you must use the -n terminal or the -w terminal if more than one storage array is connected to the host. ▪ If you are managing a storage array by using out-of-band storage management through the Ethernet connection on each controller, you must specify the <i>host-name-or-IP-address</i> of the controllers. ▪ If you have previously configured a storage array in the Enterprise Management Window, you can specify the storage array by its user-supplied name by using the -n terminal. ▪ If you have previously configured a storage array in the Enterprise Management Window, you can specify the storage array by its World Wide Identifier (WWID) by using the -w terminal. |
| -A | <p>Adds a storage array to the configuration file. If you do not follow the -A terminal with a <i>host-name-or-IP-address</i>, auto-discovery scans the local subnet for storage arrays.</p> |
| -a | <p>Adds a Simple Network Management Protocol (SNMP) trap destination or an email address alert destination.</p> |

| Terminal | Definition |
|-----------------------|---|
| | <ul style="list-style-type: none"> ▪ When you add an SNMP trap destination, the SNMP community is automatically defined as the community name for the trap, and the <code>host</code> is the IP address or Domain Name Server (DNS) host name of the system to which the trap should be sent. ▪ When you add an email address for an alert destination, the <code>email-address</code> is the email address to which you want the alert message to be sent. |
| -c | Indicates that you are entering one or more script commands to run on the specified storage array. End each command with a semicolon (;). You cannot place more than one -c terminal on the same command line. You can include more than one script command after the -c terminal. |
| -d | Shows the contents of the script configuration file. The file content has this format: <i>storage-system-name host-name1 host-name2</i> |
| -e | Runs the commands without performing a syntax check first. |
| -F (uppercase) | Specifies the email address from which all alerts will be sent. |
| -f (lowercase) | Specifies a file name that contains script commands that you want to run on the specified storage array. The -f terminal is similar to the -c terminal in that both terminals are intended for running script commands. The -c terminal runs individual script commands. The -f terminal runs a file of script commands. By default, any errors that are encountered when running the script commands in a file are ignored, and the file continues to run. To override this behavior, use the set session errorAction=stop command in the script file. |
| -g | Specifies an ASCII file that contains email sender contact information that will be included in all email alert notifications. The CLI assumes that the ASCII file is text only, without delimiters or any expected format. Do not use the -g terminal if a <code>userdata.txt</code> file exists. |
| -h | Specifies the host name that is running the SNMP agent to which the storage array is connected. Use the -h terminal with these terminals: <ul style="list-style-type: none"> ▪ -a ▪ -x |
| -I (uppercase) | Specifies the type of information to be included in the email alert notifications. You can select these values: <ul style="list-style-type: none"> ▪ eventOnly – Only the event information is included in the email. ▪ profile – The event and array profile information is included in the email. |

| Terminal | Definition |
|-----------------------|--|
| | <ul style="list-style-type: none"> ▪ supportBundle – The event and support bundle information information is included in the email. <p>You can specify the frequency for the email deliveries using the -q terminal.</p> |
| -i (lowercase) | <p>Shows the IP address of the known storage arrays. Use the -i terminal with the -d terminal. The file contents has this format:</p> <pre>storage-system-name IP-address1 IPaddress2</pre> |
| -m | <p>Specifies the host name or the IP address of the email server from which email alert notifications are sent.</p> |
| -n | <p>Specifies the name of the storage array on which you want to run the script commands. This name is optional when you use a <i>host-name-or-IP#address</i>. If you are using the in-band method for managing the storage array, you must use the -n terminal if more than one storage array is connected to the host at the specified address. The storage array name is required when the <i>host-name-or-IP-address</i> is not used. The name of the storage array that is configured for use in the Enterprise Management Window (that is, the name is listed in the configuration file) must not be a duplicate name of any other configured storage array.</p> |
| -o | <p>Specifies a file name for all output text that is a result of running the script commands. Use the -o terminal with these terminals:</p> <ul style="list-style-type: none"> ▪ -c ▪ -f <p>If you do not specify an output file, the output text goes to standard output (stdout). All output from commands that are not script commands is sent to stdout, regardless of whether this terminal is set.</p> |
| -p | <p>Specifies the password for the storage array on which you want to run commands. A password is not necessary under these conditions:</p> <ul style="list-style-type: none"> ▪ A password has not been set on the storage array. ▪ The password is specified in a script file that you are running. ▪ You specify the password by using the -c terminal and this command: <pre>set session password=password</pre> |
| -q | <p>Specifies the frequency that you want to receive event notifications and the type of information returned in the event notifications. An email alert notification containing at least the basic event information is always generated for every critical event. These values are valid for the -q terminal:</p> <ul style="list-style-type: none"> ▪ everyEvent – Information is returned with every email alert notification. ▪ 2 – Information is returned no more than once every two hours. |

| Terminal | Definition |
|-----------------------|--|
| | <ul style="list-style-type: none"> ▪ 4 – Information is returned no more than once every four hours. ▪ 8 – Information is returned no more than once every eight hours. ▪ 12 – Information is returned no more than once every 12 hours. ▪ 24 – Information is returned no more than once every 24 hours. <p>Using the -I terminal you can specify the type of information in the email alert notifications.</p> <ul style="list-style-type: none"> ▪ If you set the -I terminal to eventOnly, the only valid value for the -q terminal is everyEvent. ▪ If you set the -I terminal to either the profile value or the supportBundle value, this information is included with the emails with the frequency specified by the -q terminal. |
| -quick | <p>Reduces the amount of time that is required to run a single-line operation. An example of a single-line operation is the recreate snapshot volume command. This terminal reduces time by not running background processes for the duration of the command. Do not use this terminal for operations that involve more than one single-line operation. Extensive use of this command can overrun the controller with more commands than the controller can process, which causes operational failure. Also, status updates and configuration updates that are collected usually from background processes will not be available to the CLI. This terminal causes operations that depend on background information to fail.</p> |
| -s (uppercase) | <p>Suppresses informational messages describing the command progress that appear when you run script commands. (Suppressing informational messages is also called silent mode.) This terminal suppresses these messages:</p> <ul style="list-style-type: none"> ▪ Performing syntax check ▪ Syntax check complete ▪ Executing script ▪ Script execution complete ▪ SMcli completed successfully |
| -s (lowercase) | <p>Shows the alert settings in the configuration file when used with the -d terminal.</p> |
| -v | <p>Shows the current global status of the known devices in a configuration file when used with the -d terminal.</p> |
| -w | <p>Specifies the WWID of the storage array. This terminal is an alternate to the -n terminal. Use the -w terminal with the -d terminal to show the WWIDs of the known storage arrays. The file content has this format:</p> <pre>storage-system-name world-wide-ID IP-address1 IP-address2</pre> |

| Terminal | Definition |
|----------------|---|
| -x (uppercase) | Deletes a storage array from a configuration. |
| -x (lowercase) | Removes an SNMP trap destination or an email address alert destination. The <i>community</i> is the SNMP community name for the trap, and the <i>host</i> is the IP address or DNS host name of the system to which you want the trap sent. |
| -? | Shows usage information about the CLI commands. |

Structure of a Script Command

All script commands have the following structure:

```
command operand-data (statement-data)
```

- *command* identifies the action to be performed.
- *operand-data* represents the objects associated with a storage array that you want to configure or manage.
- *statement-data* provides the information needed to perform the command.

The syntax for *operand-data* has the following structure:

```
(object-type | allobject-types | [qualifier]
(object-type [identifier] {object-type [identifier]}) | object-types [identifier-list])
```

An object can be identified in four ways:

- Object type – Use when the command is not referencing a specific object.
- all parameter prefix – Use when the command is referencing all of the objects of the specified type in the storage array (for example, allVolumes).
- Square brackets – Use when performing a command on a specific object to identify the object (for example, volume [engineering]).
- A list of identifiers – Use to specify a subset of objects. Enclose the object identifiers in square brackets (for example, volumes [sales engineering marketing]).

A qualifier is required if you want to include additional information to describe the objects.

The object type and the identifiers that are associated with each object type are listed in this table.

Script Command Object Type Identifiers

| Object Type | Identifier |
|------------------|--------------------------|
| controller | a or b |
| drive | Tray ID and slot ID |
| replacementDrive | Tray ID and slot ID |
| driveChannel | Drive channel identifier |

| Object Type | Identifier |
|----------------|---|
| host | User label |
| hostChannel | Host channel identifier |
| hostGroup | User label |
| hostPort | User label |
| iscsiInitiator | User label or iSCSI Qualified Name (IQN) |
| iscsiTarget | User label or IQN |
| remoteMirror | Primary volume user label |
| snapshot | Volume user label |
| storageArray | Not applicable |
| tray | Tray ID |
| volume | Volume user label or volume World Wide Identifier (WWID) (<i>set</i> command only) |
| volumeCopy | Target volume user label and, optionally, the source volume user label |
| volumeGroup | User label Valid characters are alphanumeric, a hyphen, and an underscore. |

Statement data is in the form of:

- Parameter = value (such as `raidLevel=5`)
- Parameter-name (such as `batteryInstallDate`)
- Operation-name (such as `redundancyCheck`)

A user-defined entry (such as user label) is called a variable. In the syntax, it is shown in *italic* (such as *trayID* or *volumeGroupName*).

Synopsis of the Script Commands

Because you can use the script commands to define and manage the different aspects of a storage array (such as host topology, drive configuration, controller configuration, volume definitions, and volume group definitions), the actual number of commands is extensive. The commands, however, fall into general categories that are reused when you apply the commands to the different to configure or maintain a storage array. The following table lists the general form of the script commands and a definition of each command.

General Form of the Script Commands

| Syntax | Description |
|--|--|
| <code>activate object</code> { <i>statement-data</i> } | Sets up the environment so that an operation can take place or performs the operation if the environment is already set up correctly. |
| <code>autoConfigure storageArray</code> { <i>statement-data</i> } | Automatically creates a configuration that is based on the parameters that are specified in the command. |
| <code>check object</code> { <i>statement-data</i> } | Starts an operation to report on errors in the object, which is a synchronous operation. |
| <code>clear object</code> { <i>statement-data</i> } | Discards the contents of some attributes of an object. This operation is destructive and cannot be reversed. |
| <code>create object</code> { <i>statement-data</i> } | Creates an object of the specified type. |
| <code>deactivate object</code> { <i>statement-data</i> } | Removes the environment for an operation. |
| <code>delete object</code> | Deletes a previously created object. |
| <code>diagnose object</code> { <i>statement-data</i> } | Runs a test and shows the results. |
| <code>disable object {<i>statement-data</i>}</code> | Prevents a feature from operating. |
| <code>download object</code> { <i>statement-data</i> } | Transfers data to the storage array or to the hardware that is associated with the storage array. |
| <code>enable object</code> { <i>statement-data</i> } | Sets a feature to operate. |
| <code>load object</code> { <i>statement-data</i> } | Transfers data to the storage array or to the hardware that is associated with the storage array. This command is functionally similar to the download command. |
| <code>recopy object</code> { <i>statement-data</i> } | Restarts a volume copy operation by using an existing volume copy pair. You can change the parameters before the operation is restarted. |
| <code>recover object</code> { <i>statement-data</i> } | Re-creates an object from saved configuration data and the statement parameters. (This command is similar to the create command.) |
| <code>recreate object</code> { <i>statement-data</i> } | Restarts a snapshot operation by using an existing snapshot volume. You can change the parameters before the operation is restarted. |

| Syntax | Description |
|--|--|
| <code>remove object</code> { <i>statement-data</i> } | Removes a relationship from between objects. |
| <code>repair object</code> { <i>statement-data</i> } | Repairs errors found by the <code>check</code> command. |
| <code>reset object</code> { <i>statement-data</i> } | Returns the hardware or an object to an initial state. |
| <code>resume object</code> | Starts a suspended operation. The operation starts where it left off when it was suspended. |
| <code>revive object</code> | Forces the object from the Failed state to the Optimal state. Use this command only as part of an error recovery procedure. |
| <code>save object</code> { <i>statement-data</i> } | Writes information about the object to a file. |
| <code>set object</code> { <i>statement-data</i> } | Changes object attributes. All changes are completed when the command returns. |
| <code>show object</code> { <i>statement-data</i> } | Shows information about the object. |
| <code>start object</code> { <i>statement-data</i> } | Starts an asynchronous operation. You can stop some operations after they have started. You can query the progress of some operations. |
| <code>stop object</code> { <i>statement-data</i> } | Stops an asynchronous operation. |
| <code>suspend object</code> { <i>statement-data</i> } | Stops an operation. You can then restart the suspended operation, and it continues from the point where it was suspended. |

Recurring Syntax Elements

Recurring syntax elements are a general category of parameters and options that you can use in the script commands. The [Recurring Syntax Elements](#) table lists the recurring syntax parameters and the values that you can use with the recurring syntax parameters. The conventions used in the recurring syntax elements are listed in the following table.

| Convention | Definition |
|---------------------------|---|
| <code>a b</code> | Alternative ("a" or "b") |
| <i>italicized-words</i> | A terminal that needs user input to fulfill a parameter (a response to a variable) |
| [...] (square brackets) | Zero or one occurrence (square brackets are also used as a delimiter for some command parameters) |

| Convention | Definition |
|------------------------|--|
| { ... } (curly braces) | Zero or more occurrences |
| (a b c) | Choose only one of the alternatives |
| bold | A terminal that needs a command parameter entered to start an action |

Recurring Syntax Elements

| Recurring Syntax | Syntax Value |
|--|---|
| <i>raid-level</i> | (0 1 3 5 6) |
| <i>repository-raid-level</i> | (1 3 5 6) |
| <i>capacity-spec</i> | <i>integer-literal</i> [KB MB GB TB Bytes] |
| <i>segment-size-spec</i> | <i>integer-literal</i> |
| <i>boolean</i> | (TRUE FALSE) |
| <i>user-label</i> | <i>string-literal</i> Valid characters are alphanumeric, the dash, and the underscore. |
| <i>user-label-list</i> | <i>user-label</i> { <i>user-label</i> } |
| <i>create-raid-vol-attr-value-list</i> | <i>create-raid-volume-attribute-value-pair</i> { <i>create-raid-volume-attribute-value-pair</i> } |
| <i>create-raid-volume-attribute-value-pair</i> | capacity= <i>capacity-spec</i> owner=(a b) cacheReadPrefetch=(TRUE FALSE) segmentSize= <i>integer-literal</i> usageHint= <i>usage-hint-spec</i> |
| <i>noncontroller-trayID</i> | (0-99) |
| <i>slotID</i> | (1-32) |
| <i>portID</i> | (0-127) |
| <i>drive-spec</i> | <i>trayID</i> , <i>slotID</i> Or <i>trayID</i> , <i>drawerID</i> , <i>slotID</i> A drive is defined as two or three interger literal values separated by a comma. Low-density trays require two values. High-density trays, those trays that have drawers, require three values. |
| <i>drive-spec-list</i> | <i>drive-spec</i> <i>drive-spec</i> |
| <i>trayID-list</i> | <i>trayID</i> { <i>trayID</i> } |
| <i>esm-spec-list</i> | <i>esm-spec</i> { <i>esm-spec</i> } |

| Recurring Syntax | Syntax Value |
|---|---|
| <i>esm-spec</i> | <i>trayID</i> , (left right) |
| <i>hex-literal</i> | <i>0xhexadecimal-literal</i> |
| <i>volumeGroup-number</i> | <i>integer-literal</i> |
| <i>filename</i> | <i>string-literal</i> |
| <i>error-action</i> | (stop continue) |
| <i>drive-channel-identifier</i> (four drive ports per tray) | (1 2 3 4) |
| <i>drive-channel-identifier</i> (eight drive ports per tray) | (1 2 3 4 5 6 7 8) |
| <i>drive-channel-identifier-list</i> | <i>drive-channel-identifier</i> { <i>drive-channel#identifier</i> } |
| <i>host-channel-identifier</i> (four host ports per tray) | (a1 a2 b1 b2) |
| <i>host-channel-identifier</i> (eight host ports per tray) | (a1 a2 a3 a4 b1 b2 b3 b4) |
| <i>host-channel-identifier</i> (16 host ports per tray) | (a1 a2 a3 a4 a5 a6 a7 a8 b1 b2 b3 b4 b5 b6 b7 b8) |
| <i>drive-type</i> | (fibre SATA SAS) |
| <i>drive-media-type</i> | (HDD SSD unknown allMedia) <i>HDD</i> means hard disk drive. <i>SSD</i> means solid state disk. |
| <i>feature-identifier</i> | (storagePartition2 storagePartition4 storagePartition8 storagePartition16 storagePartition64 storagePartition96 storagePartition128 storagePartition256 storagePartitionMax snapshot snapshot2 snapshot4 snapshot8 snapshot16 remoteMirror8 remoteMirror16 remoteMirror32 remoteMirror64 remoteMirror128 volumeCopy goldKey mixedDriveTypes highPerformanceTier SSDSupport safeStoreSecurity safeStoreExternalKeyMgr dataAssurance) |

| Recurring Syntax | Syntax Value |
|---------------------------------------|---|
| | <p>To use the High Performance Tier premium feature, you must configure a storage array as one of these:</p> <ul style="list-style-type: none"> ▪ SHIPPED_ENABLED ▪ SHIPPED_ENABLED=FALSE; KEY_ENABLED=TRUE |
| <i>repository-spec</i> | <i>instance-based-repository-spec</i> <i>count-based-repository-spec</i> |
| <i>instance-based-repository-spec</i> | <pre>(repositoryRAIDLevel =repository-raid-level repositoryDrives= (drive-spec-list) [repositoryVolumeGroupUserLabel =user-label] [trayLossProtect=(TRUE FALSE)¹] [drawerLossProtect=(TRUE FALSE)²] (repositoryVolumeGroup=user-label [freeCapacityArea=integer-literal³])</pre> <p>Specify the <code>repositoryRAIDLevel</code> parameter with the <code>repositoryDrives</code> parameter. Do not specify the RAID level or the drives with the volume group. Do not set a value for the <code>trayLossProtect</code> parameter when you specify a volume group.</p> |
| <i>count-based-repository-spec</i> | <pre>repositoryRAIDLevel =repository-raid-level repositoryDriveCount=integer-literal [repositoryVolumeGroupUserLabel =user-label] [driveType=drive-type⁴] [trayLossProtect=(TRUE FALSE)¹] [drawerLossProtect=(TRUE FALSE)²] [dataAssurance=(none enabled)⁵] </pre> |
| <i>wwID</i> | <i>string-literal</i> |
| <i>gid</i> | <i>string-literal</i> |
| <i>host-type</i> | <i>string-literal</i> <i>integer-literal</i> |
| <i>host-card-identifier</i> | (1 2 3 4) |
| <i>backup-device-identifier</i> | (1 n all) n is a specific slot number. Specifying a11 includes all of the cache backup devices available to the entire storage array. |
| <i>nvsram-offset</i> | <i>hex-literal</i> |

| Recurring Syntax | Syntax Value |
|--|--|
| <i>nvsram-byte-setting</i> | <i>nvsram-value</i> = <i>0hexadecimal</i> <i>integer-literal</i> The <i>0hexadecimal</i> value is typically a value from 0x0000 to 0xFFFF. |
| <i>nvsram-bit-setting</i> | <i>nvsram-mask</i> , <i>nvsram-value</i> = <i>0hexadecimal</i> , <i>0hexadecimal</i> <i>integer-literal</i> The <i>0hexadecimal</i> value is typically a value from 0x0000 to 0xFFFF. |
| <i>ip-address</i> | (0-255).(0-255).(0-255).(0-255) |
| <i>ipv6-address</i> | (0-FFFF):(0-FFFF):(0-FFFF):(0-FFFF):(0-FFFF):(0-FFFF):(0-FFFF):(0-FFFF) You must enter all 32 hexadecimal characters. |
| <i>autoconfigure-vols-attr-value-list</i> | <i>autoconfigure-vols-attr-value-pair</i> { <i>autoconfigure-vols-attr-value-pair</i> } |
| <i>autoconfigure-vols-attr-value-pair</i> | <i>driveType=drive-type</i> <i>driveMediaType=drive-media-type</i> <i>raidLevel=raid-level</i> <i>volumeGroupWidth=integer-literal</i> <i>volumeGroupCount=integer-literal</i> <i>volumesPerGroupCount=integer-literal</i> ⁶ <i>hotSpareCount=integer-literal</i> <i>segmentSize=segment-size-spec</i> <i>cacheReadPrefetch=(TRUE FALSE)</i> <i>securityType=(none capable enabled)</i> ⁷ <i>dataAssurance=(none enabled)</i> ⁵ |
| <i>create-volume-copy-attr-value-list</i> | <i>create-volume-copy-attr-value-pair</i> { <i>create-volume-copy-attr-value-pair</i> } |
| <i>create-volume-copy-attr-value-pair</i> | <i>copyPriority=(highest high medium low lowest)</i> <i>targetReadOnlyEnabled=(TRUE FALSE)</i> <i>copyType=(offline online)</i> <i>repositoryPercentOfBase=(20 40 60 120 default)</i> <i>repositoryGroupPreference=(sameAsSource otherThanSource default)</i> |
| <i>recover-raid-volume-attr-value-list</i> | <i>recover-raid-volume-attr-value-pair</i> { <i>recover-raid-volume-attr-value-pair</i> } |
| <i>recover-raid-volume-attr-value-pair</i> | <i>owner=(a b)</i> <i>cacheReadPrefetch=(TRUE FALSE)</i> <i>dataAssurance=(none enabled)</i> |

| Recurring Syntax | Syntax Value |
|-------------------------------------|--|
| <i>cache-flush-modifier-setting</i> | immediate, 0, .25, .5, .75, 1, 1.5, 2, 5, 10, 20, 60, 120, 300, 1200, 3600, infinite |
| <i>serial-number</i> | string-literal |
| <i>usage-hint-spec</i> | usageHint=(multiMedia database fileSystem) |
| <i>iscsiSession</i> | [<i>session-identifier</i>] |
| <i>iscsi-host-port</i> | (1 2 3 4) The host port number might be 2, 3, or 4 depending on the type of controller you are using. |
| <i>ethernet-port-options</i> | enableIPv4=(TRUE FALSE) enableIPv6=(TRUE FALSE) IPv6LocalAddress= <i>ipv6-address</i> IPv6RoutableAddress= <i>ipv6-address</i> IPv6RouterAddress= <i>ipv6-address</i> IPv4Address= <i>ip-address</i> IPv4ConfigurationMethod=(static dhcp) IPv4GatewayIP= <i>ip-address</i> IPv4SubnetMask= <i>ip-address</i> duplexMode=(TRUE FALSE) portSpeed=(autoNegotiate 10 100 1000) |
| <i>iscsi-host-port-options</i> | IPv4Address= <i>ip-address</i> IPv6LocalAddress= <i>ipv6-address</i> IPv6RoutableAddress= <i>ipv6-address</i> IPv6RouterAddress= <i>ipv6-address</i> enableIPv4=(TRUE FALSE) enableIPv6=(TRUE FALSE) enableIPv4Priority=(TRUE FALSE) enableIPv6Priority=(TRUE FALSE) IPv4ConfigurationMethod=(static dhcp) IPv6ConfigurationMethod=(static auto) IPv4GatewayIP= <i>ip-address</i> IPv6HopLimit= <i>integer</i> IPv6NdDetectDuplicateAddress= <i>integer</i> IPv6NdReachableTime= <i>time-interval</i> IPv6NdRetransmitTime= <i>time-interval</i> IPv6NdTimeOut= <i>time-interval</i> IPv4Priority= <i>integer</i> IPv6Priority= <i>integer</i> IPv4SubnetMask= <i>ip-address</i> IPv4VlanId= <i>integer</i> IPv6VlanId= <i>integer</i> |

| Recurring Syntax | Syntax Value |
|---|---|
| | maxFramePayload= <i>integer</i> tcpListeningPort= <i>tcp-port-id</i> portSpeed=(autoNegotiate 1 10) |
| <i>test-devices-list</i> | <i>test-devices</i> { <i>test-devices</i> } |
| <i>test-devices</i> | controller=(<i>a</i> <i>b</i>) esms=(<i>esm-spec-list</i>) drives=(<i>drive-spec-list</i>) |
| <i>snapshot-schedule-attribute-value-list</i> | <i>snapshot-schedule-attribute-value-pair</i> { <i>snapshot-schedule-attribute-value-pair</i> } |
| <i>time-zone-spec</i> | (GMT+HH:MM GMT-HH:MM) [dayLightSaving=HH:MM] |
| <i>snapshot-schedule-attribute-value-pair</i> | startDate=MM:DD:YY scheduleDay=(<i>dayOfWeek</i> all) startTime=HH:MM scheduleInterval= <i>interger</i> endDate=(MM:DD:YY noEndDate) timesPerDay= <i>interger</i> |

¹For tray loss protection to work, each drive in a volume group must be in a separate tray. If you set the `trayLossProtect` parameter to **TRUE** and you have selected more than one drive from any one tray, the storage array returns an error. If you set `trayLossProtect` parameter to **FALSE**, the storage array performs operations, but the volume group that you create might not have tray loss protection.

If you set the `trayLossProtect` parameter to **TRUE**, the storage array returns an error if the controller firmware cannot find drives that will enable the new volume group to have tray loss protection. If you set the `trayLossProtect` parameter to **FALSE**, the storage array performs the operation even if it means that the volume group might not have tray loss protection.

²In trays that have drawers for holding the drives, drawer loss protection determines whether data on a volume is accessible or inaccessible if a drawer fails. To help make sure that your data is accessible, set the `drawerLossProtect` parameter to **TRUE**. For drawer loss protection to work, each drive in a volume group must be in separate drawers. If you have a storage array configuration in which a volume group spans several trays, you must make sure that the setting for drawer loss protection works with the setting for tray loss protection. If you set the `trayLossProtect` parameter to **TRUE**, you must set the `drawerLossProtect` parameter to **TRUE**. If you set the `trayLossProtect` parameter to **TRUE**, and you set the `drawerLossProtect` parameter to **FALSE**, the storage array returns an error message and a storage array configuration will not be created.

³To determine if a free capacity area exists, run the `show volumeGroup` command.

⁴The default drive (drive type) is **ibre** (Fibre Channel).

The `driveType` parameter is not required if only one type of drive is in the storage array. If you use the `driveType` parameter, you also must use the `hotSpareCount` parameter and the `volumeGroupWidth` parameter. If you do not use the `driveType` parameter, the configuration defaults to Fibre Channel drives.

⁵The `dataAssurance` parameter applies to the drives in a volume group. Using the `dataAssurance` parameter, you can specify that protected drives must be selected for a volume group. If you want to set the `dataAssurance` parameter to `enabled`, all of the drives in the volume group must be capable of data assurance. You cannot have a mix of drives that are capable of data assurance and drives that are not capable of data assurance in the volume group.

⁶The `volumesPerGroupCount` parameter is the number of equal-capacity volumes per volume group.

⁷The `securityType` parameter enables you to specify the security setting for a volume group that you are creating. All of the volumes are also set to the security setting that you choose. Available options for setting the security setting include:

- **none** – The volume group is not secure.
- **capable** – The volume group is security capable, but security has not been enabled.
- **enabled** – The volume group is security enabled.



NOTE A storage array security key must already be created for the storage array if you want to set `securityType=enabled`. (To create a storage array security key, use the `create storageArray securityKey` command).

Naming Conventions

- Names can have a maximum of 30 characters.
- You can use any combination of alphanumeric characters, hyphens, and underscores for the names of the following components:
 - Storage arrays
 - Host groups
 - Hosts
 - Volume groups
 - Volumes
 - HBA host ports
- You must use unique names. If you do not use unique names, the controller firmware returns an error.
- If the name contains more than one word, hyphens, or underscores, enclose the name in double quotation marks (" "). In some usages, you must also surround the name with square brackets ([]). The description of each parameter indicates whether you need to enclose a parameter in double quotation marks, square brackets, or both.
- The name character string cannot contain a new line.
- On Windows operating systems, you must enclose the name between two back slashes (\) in addition to other delimiters. For example, the following name is used in a command that runs under a Windows operating system:

```
[\"Engineering\"]
```

- For a UNIX operating system and, when used in a script file, the name appears as in the following example:

```
[\"Engineering\"]
```

- When you enter a World Wide Identifier (WWID) of an HBA host port, some usages require that you surround the WWID with double quotation marks. In other uses, you must surround the WWID with angle brackets (<>). The description of the WWID parameter indicates whether you need to enclose the WWID in double quotation marks or angle brackets.

Entering Numerical Names

When the storage management software automatically configures a storage array, the storage management software assigns names that consist of numerical characters. Names that consist only of numerical characters are valid names. Numerical character names, however, must be treated differently than names that start with alphabetic characters.

When you enter a script command that requires a name, the script engine looks for a name that starts with an alphabetic character. The Script Engine might not recognize the following names:

- Names that are only numbers, such as 1 or 2
- Names that start with a number, such as 1Disk or 32Volume

To enter a name that consists only of numerical characters so that the Script Engine will recognize the name, use a combination of back slashes and double quotation marks. The following are examples of how you can enter names that consist only of numerical characters or start with numerical characters:

- ["1"]
- ["1Disk"]

Formatting CLI Commands

Double quotation marks (" ") that are used as part of a name or label require special consideration when you run the CLI commands and the script commands on a Microsoft Windows operating system.

When double quotation marks (" ") are part of a name or value, you must insert a backslash (\) before each double quotation mark character. For example:

```
-c "set storageArray userLabel=\"Engineering\";"
```

In this example, "Engineering" is the storage array name. A second example is:

```
-n \"My\"_Array
```

In this example, "My"_Array is the name of the storage array.

You cannot use double quotation marks (" ") as part of a character string (also called string literal) within a script command. For example, you cannot enter the following string to set the storage array name to "Finance" Array:

```
-c "set storageArray userLabel=\"\"Finance\"Array\";"
```

In the Linux operating system and the Solaris operating system, the delimiters around names or labels are single quotation marks (' '). The UNIX versions of the previous examples are as follows:

```
-c 'set storageArray userLabel="Engineering";'
```

```
-n "My"_Array
```

In a Windows operating system, if you do not use double quotation marks (" ") around a name, you must insert a caret (^) before each special script character. Special characters are ^, |, <, and >.

Insert a caret before each special script character when used with the terminals `-n`, `-o`, `-f`, and `-p`. For example, to specify storage array CLI>CLIENT, enter this string:

```
-n CLI^>CLIENT
```

Insert one caret (^) before each special script character when used within a string literal in a script command. For example, to change the name of a storage array to FINANCE_>_PAYROLL, enter the following string:

```
-c "set storageArray userLabel=\"FINANCE_^|_PAYROLL\";"
```

Formatting Rules for Script Commands

Syntax unique to a specific script command is explained in the Notes section at the end of each script command description.

Case sensitivity – The script commands are not case sensitive. You can type the script commands in lowercase, uppercase, or mixed case. (In the following command descriptions, mixed case is used as an aid to reading the command names and understanding the purpose of the command.)

Spaces – You must enter spaces in the script commands as they are shown in the command descriptions.

Square brackets – Square brackets are used in two ways:

- As part of the command syntax.
- To indicate that the parameters are optional. The description of each parameter tells you if you need to enclose a parameter value in square brackets.

Parentheses – Parentheses shown in the command syntax enclose specific choices for a parameter. That is, if you want to use the parameter, you must enter one of the values enclosed in parentheses. Generally, you do not include parentheses in a script command; however, in some instances, when you enter lists, you must enclose the list in parentheses. Such a list might be a list of tray ID values and slot ID values. The description of each parameter tells you if you need to enclose a parameter value in parentheses.

Vertical bars – Vertical bars in a script command indicate “or” and separate the valid values for the parameter. For example, the syntax for the `raidLevel` parameter in the command description appears as follows:

```
raidLevel=(0 | 1 | 3 | 5 | 6)
```

To use the `raidLevel` parameter to set RAID Level 5, enter this value:

```
raidLevel=5
```

Drive locations – The CLI commands that identify drive locations support both high-capacity drive trays and low-capacity drive trays. A high-capacity drive tray has drawers that hold the drives. The drawers slide out of the drive tray to provide access to the drives. A low-capacity drive tray does not have drawers. For a high-capacity drive tray, you must specify the identifier (ID) of the drive tray, the ID of the drawer, and the ID of the slot in which a drive resides. For a low-capacity drive tray, you need only specify the ID of the drive tray and the ID of the slot in which a drive resides. For a low-capacity drive tray, an alternative method for identifying a location for a drive is to specify the ID of the drive tray, set the ID of the drawer to 0, and specify the ID of the slot in which a drive resides. Separate the ID values with a comma. If you enter more than one set of ID values, separate each set of values with a space. Enclose the set of values in parentheses. For example:

```
(1,1 1,2 1,3 1,4 2,1 2,2 2,3 2,4)
```

or, for a high-capacity drive tray, this example:

```
(1,1,1 1,2,2 1,3,3 1,4,4 2,1,1 2,2,2 2,3,3 2,4,4)
```

Italicized terms – Italicized terms in the command indicate a value or information that you need to provide. For example, when you encounter the italicized term:

numberOfDrives

Replace the italicized term with a value for the number of drives that you want to include with the script command.

Semicolon – Script commands must end with a semicolon (;). You can enter more than one script command on the command line or in a script file. For example, a semicolon is used to separate each script command in the following script file.

```
create volume drives=(0,2 0,3 1,4 1,5 2,6 2,7) raidLevel=5
userLabel="v1" capacity=2gb owner=a;
create volume volumeGroup=2 userLabel="v2" capacity=1gb owner=b;
create volume volumeGroup=2 userLabel="v3" capacity=1gb owner=a;

create volume drives=(0,4 0,5 1,6 1,7 2,8 2,9) raidLevel=5
userLabel="v4" capacity=2gb owner=b;
create volume volumeGroup=3 userLabel="v5" capacity=1gb owner=a;
create volume volumeGroup=3 userLabel="v6" capacity=1gb owner=b;
```

Usage Guidelines

This list provides guidelines for writing script commands on the command line:

- You must end all commands with a semicolon (;).
- You can enter more than one command on a line, but you must separate each command with a semicolon (;).
- You must separate each base command and its associated primary parameters and secondary parameters with a space.
- The script engine is not case sensitive. You can enter commands by using uppercase letters, lowercase letters, or mixed-case letters.
- Add comments to your scripts to make it easier for you and future users to understand the purpose of the script commands. (For information about how to add comments, see ["Adding Comments to a Script File."](#))



NOTE While the CLI commands and the script commands are not case sensitive, user labels (such as for volumes, hosts, or host ports) are case sensitive. If you try to map to an object that is identified by a user label, you must enter the user label exactly as it is defined, or the CLI commands and the script commands will fail.

Detailed Error Reporting

Data collected from an error encountered by the CLI is written to a file. Detailed error reporting under the CLI works as follows:

- If the CLI must abnormally end running CLI commands and script commands, error data is collected and saved before the CLI finishes.
- The CLI saves the error data by writing the data to a standard file name.
- The CLI automatically saves the data to a file. Special command line options are not required to save the error data.
- You are not required to perform any action to save the error data to a file.
- The CLI does not have any provision to avoid over-writing an existing version of the file that contains error data.

For error processing, errors appear as two types:

- Terminal errors or syntax errors that you might enter
- Exceptions that occur as a result of an operational error

When the CLI encounters either type of error, the CLI writes information that describes the error directly to the command line and sets a return code. Depending on the return code, the CLI also might write additional information about which terminal caused the error. The CLI also writes information about what it was expecting in the command syntax to help you identify any syntax errors that you might have entered.

When an exception occurs while a command is running, the CLI captures the error. At the end of processing the command (after the command processing information has been written to the command line), the CLI automatically saves the error information to a file.

The name of the file to which error information is saved is `excprpt.txt`. The CLI tries to place the `excprpt.txt` file in the directory that is specified by the system property `devmgr.datadir`. If for any reason the CLI cannot place the file in the directory specified by `devmgr.datadir`, the CLI saves the `excprpt.txt` file in the same directory from which the CLI is running. You cannot change the file name or the location. The `excprpt.txt` file is overwritten every time that an exception occurs. If you want to save the information in the `excprpt.txt` file, you must copy the information to a new file or a new directory.

Exit Status

This table lists the exit statuses that might be returned and the meaning of each status.

| Status Value | Meaning |
|--------------|---|
| 0 | The command terminated without an error. |
| 1 | The command terminated with an error. Information about the error also appears. |
| 2 | The script file does not exist. |
| 3 | An error occurred while opening an output file. |
| 4 | A storage array was not at the specified address. |
| 5 | Addresses specify different storage arrays. |
| 6 | A storage array name does not exist for the host agent that is connected. |

| Status Value | Meaning |
|--------------|---|
| 7 | The storage array name was not at the specified address. |
| 8 | The storage array name was not unique. |
| 9 | The storage array name was not in the configuration file. |
| 10 | A management class does not exist for the storage array. |
| 11 | A storage array was not found in the configuration file. |
| 12 | An internal error occurred. |
| 13 | Invalid script syntax was found. |
| 14 | The controller was unable to communicate with the storage array. |
| 15 | A duplicate argument was entered. |
| 16 | An execution error occurred. |
| 17 | A host was not at the specified address. |
| 18 | The WWID was not in the configuration file. |
| 19 | The WWID was not at the address. |
| 20 | An unknown IP address was specified. |
| 21 | The Event Monitor configuration file was corrupted. |
| 22 | The storage array was unable to communicate with the Event Monitor. |
| 23 | The controller was unable to write alert settings. |
| 24 | The wrong organizer node was specified. |
| 25 | The command was not available. |
| 26 | The device was not in the configuration file. |
| 27 | An error occurred while updating the configuration file. |
| 28 | An unknown host error occurred. |
| 29 | The sender contact information file was not found. |
| 30 | The sender contact information file could not be read. |
| 31 | The <code>userdata.txt</code> file exists. |
| 32 | An invalid <code>-I</code> value in the email alert notification was specified. |
| 33 | An invalid <code>-F</code> value in the email alert notification was specified. |

Adding Comments to a Script File

The script engine looks for certain characters or a command to show comments. You can add comments to a script file in three ways:

1. Add text after two forward slashes (//) as a comment until an end-of-line character is reached. If the script engine does not find an end-of-line character in the script after processing a comment, an error message appears, and the script operation is terminated. This error usually occurs when a comment is placed at the end of a script and you have forgotten to press the **Enter** key.

```
// Deletes the existing configuration.  
set storageArray resetConfiguration=true;
```

2. Add text between /* and */ as a comment. If the script engine does not find both a starting comment notation and an ending comment notation, an error message appears, and the script operation is terminated.

```
/* Deletes the existing configuration */  
set storageArray resetConfiguration=true;
```

3. Use the **show** statement to embed comments in a script file that you want to appear while the script file is running. Enclose the text that you want to appear by using double quotation marks (" ").

```
show "Deletes the existing configuration";  
set storageArray resetConfiguration=true;
```

Firmware Compatibility Levels

The script commands and the command parameters do not run under all versions of the controller firmware. The script commands in the following sections list the minimum firmware levels under which the script commands can run. In the script commands, the firmware levels are listed under the heading "Minimum Firmware Level." This list describes how to interpret the information about the firmware levels.

- If a script command does not list a minimum controller firmware level, the script command and all of the parameters associated with that script command can run under any level of controller firmware.
- A controller firmware number without any explanatory information indicates that the controller firmware level applies to the entire script command and all of the parameters for that script command.
- A controller firmware number that is associated with a parameter indicates the minimum controller firmware level under which the parameter can run.



NOTE The minimum controller firmware level indicates support by the software that releases the command, as well as support by all storage management software that picks up usage. CLI support capabilities depend on the hardware used. When an unsupported command is entered, an error message appears.

Examples of Firmware Compatibility Levels

The **create hostGroup** command has the following section.

Minimum Firmware Level

5.20

This level indicates that the entire script command runs under a minimum of controller firmware version 5.20.

The `show volume` command has the following section.

Minimum Firmware Level

5.00

5.43 adds the `summary` parameter

These notations indicate that the script command and all of the parameters except `summary` run under a minimum of controller firmware version 5.00. The `summary` parameter runs under a minimum of controller firmware version 5.43.

Script Commands



ATTENTION The script commands are capable of damaging a configuration and causing loss of data access if not used correctly – Command operations are performed as soon as you run the commands. Some commands can immediately delete configurations or data. Before using the script commands, make sure that you have backed up all data, and have saved the current configuration so that you can reinstall it if the changes you make do not work.

The description of each scriptcommand is intended to provide all of the information that you need to be able to use the command. If, however, you have questions about command usage, these sections provide additional information that can help you use the script commands:

- [“Naming Conventions”](#) lists the general rules for entering the names of storage array entities, such as volumes or drives, with the script commands.
 - [“Formatting CLI Commands”](#) lists the general formatting rules that apply to the CLI command wrapper.
 - [“Formatting Rules for Script Commands”](#) lists the general formatting rules that apply to the script command syntax.
 - [“Firmware Compatibility Levels”](#) explains how to interpret the firmware level information.
 - [“Commands Listed by Function”](#) lists the script commands organized into groups related to the physical features, the logical features, and the operational features of the storage array.
 - [“Commands Listed Alphabetically”](#) lists the script commands alphabetically and, for each script command, includes script command name, syntax, and parameters.
-



IMPORTANT Terminology differences – The names of components and features change from time to time; however, the command syntax does not change at the same time. You will notice minor differences between the terminology used to describe components and features and the terminology used in the syntax to describe those same items when used in a command name, a parameter, or a variable.

Commands Listed by Function

Controller Commands

[Clear Drive Channel Statistics](#)

[Diagnose Controller](#)

[Diagnose Controller iSCSI Host Cable](#)

[Enable Controller Data Transfer](#)

[Reset Controller](#)

[Save Controller NVSRAM](#)

[Save Drive Channel Fault Isolation Diagnostic Status](#)

[Set Controller](#)

[Set Controller Service Action Allowed Indicator](#)

[Set Drive Channel Status](#)

Set Host Channel

Show Cache Backup Device Diagnostic Status

Show Cache Memory Diagnostic Status

Show Controller

Show Controller Diagnostic Status

Show Controller NVSRAM

Show Drive Channel Statistics

Show Host Interface Card Diagnostic Status

Start Cache Backup Device Diagnostic

Start Cache Memory Diagnostic

Start Configuration Database Diagnostic

Start Controller Diagnostic

Start Controller Trace

Start Drive Channel Fault Isolation Diagnostics

Start Drive Channel Locate

Start Host Interface Card Diagnostic

Stop Cache Backup Device Diagnostic

Stop Cache Memory Diagnostic

Stop Configuration Database Diagnostic

Stop Controller Diagnostic

Stop Drive Channel Fault Isolation Diagnostics

Stop Drive Channel Locate

Stop Host Interface Card Diagnostic

Drive Commands

Download Drive Firmware

Replace Drive

Revive Drive

Save Drive Channel Fault Isolation Diagnostic Status

Save Drive Log

Set Drive Hot Spare

Set Drive Service Action Allowed Indicator

Set Drive State

Set Foreign Drive to Native

Show Drive

Show Drive Download Progress

Start Drive Channel Fault Isolation Diagnostics

Start Drive Initialize

Start Drive Locate

Start Drive Reconstruction

Start Secure Drive Erase

Stop Drive Channel Fault Isolation Diagnostics

Stop Drive Locate

Host Topology Commands

Activate iSCSI Initiator

Create Host

Create Host Group

Create Host Port

Create iSCSI Initiator

Delete Host

Delete Host Group

Delete Host Port

Delete iSCSI Initiator

Set Host

Set Host Channel

Set Host Group

Set Host Port

Set iSCSI Initiator

Set iSCSI Target Properties

Show Current iSCSI Sessions

Show Host Ports

iSCSI Commands

Create iSCSI Initiator

Delete iSCSI Initiator

Reset Storage Array iSCSI Baseline

Save Storage Array iSCSI Statistics

Set iSCSI Initiator

Set iSCSI Target Properties

Show Current iSCSI Sessions

Show Storage Array Negotiation Defaults

Show Storage Array Unconfigured iSCSI Initiators

Start iSCSI DHCP Refresh

Stop Storage Array iSCSI Session

Remote Volume Mirroring Commands

Activate Remote Volume Mirroring Feature

Check Remote Mirror Status

Create Remote Mirror

Deactivate Remote Mirror

Diagnose Remote Mirror

Re-create Remote Volume Mirroring Repository Volume

Remove Remote Mirror

Resume Remote Mirror

Set Remote Mirror

Show Remote Volume Mirroring Volume Candidates

Show Remote Volume Mirroring Volume Synchronization Progress

Start Remote Volume Mirroring Synchronization

Suspend Remote Mirror

Session Command

Set Session

Snapshot Commands

Create Snapshot Volume

Delete Snapshot Volume

Re-create Snapshot

Resume Snapshot Rollback

Set Snapshot Volume

Start Snapshot Rollback

Stop Snapshot

Stop Snapshot Rollback

Storage Array Commands

Activate Storage Array Firmware

Autoconfigure Storage Array

Autoconfigure Storage Array Hot Spares

Clear Storage Array Configuration

Clear Storage Array Event Log

Clear Storage Array Firmware Pending Area

Create Storage Array Security Key

Disable External Security Key Management

Disable Storage Array Feature

Download Storage Array Drive Firmware

Download Storage Array Firmware/NVSRAM

Download Storage Array NVSRAM

Enable External Security Key Management

Enable Storage Array Feature

Export Storage Array Security Key
Import Storage Array Security Key
Load Storage Array DBM Database"
Re-create External Security Key
Reset Storage Array Battery Install Date
Reset Storage Array Diagnostic Data
Reset Storage Array Infiniband Statistics Baseline
Reset Storage Array iSCSI Baseline
Reset Storage Array RLS Baseline
Reset Storage Array SAS PHY Baseline
Reset Storage Array SOC Baseline
Reset Storage Array Volume Distribution
Save Storage Array Configuration
Save Storage Array DBM Database
Save Storage Array DBM Validator
Save Storage Array Diagnostic Data
Save Storage Array Events
Save Storage Array Firmware Inventory
Save Storage Array InfiniBand Statistics
Save Storage Array iSCSI Statistics
Save Storage Array Performance Statistics
Save Storage Array RLS Counts
Save Storage Array SAS PHY Counts
Save Storage Array SOC Counts
Save Storage Array State Capture
Save Storage Array Support Data
Set Storage Array
Set Storage Array ICMP Response

Set Storage Array iSNS Server IPv4 Address
Set Storage Array iSNS Server IPv6 Address
Set Storage Array iSNS Server Listening Port
Set Storage Array iSNS Server Refresh
Set Storage Array Learn Cycle
Set Storage Array Redundancy Mode
Set Storage Array Security Key
Set Storage Array Time
Set Storage Array Tray Positions
Show Storage Array
Show Storage Array Auto Configure
Show Storage Array Host Topology
Show Storage Array LUN Mappings
Show Storage Array Negotiation Defaults
Show Storage Array Unreadable Sectors
Show Storage Array Unconfigured iSCSI Initiators
Start Secure Drive Erase
Start Storage Array iSNS Server Refresh
Start Storage Array Locate
Stop Storage Array Drive Firmware Download
Stop Storage Array iSCSI Session
Stop Storage Array Locate
Validate Storage Array Security Key

Tray Commands

Download Power Supply Firmware
Download Tray Configuration Settings
Save Tray Log
Set Drawer Service Action Allowed Indicator

Set Tray Alarm

Set Tray Identification

Set Tray Service Action Allowed Indicator

Start Tray Locate

Stop Tray Locate

Uncategorized Commands

Set Storage Array ICMP Response

Set Storage Array iSNS Server IPv4 Address

Set Storage Array iSNS Server IPv6 Address

Set Storage Array iSNS Server Listening Port

Set Storage Array iSNS Server Refresh

Set Storage Array Unnamed Discovery Session

Show Storage Array Negotiation Defaults

Show String

Volume Commands

Check Volume Parity

Clear Volume Reservations

Clear Volume Unreadable Sectors

Create RAID Volume (Automatic Drive Select)

Create RAID Volume (Free Extent Based Select)

Create RAID Volume (Manual Drive Select)

Delete Volume

Recover RAID Volume

Remove Volume LUN Mapping

Repair Volume Parity

Set Volume

Show Volume

Show Volume Action Progress

Show Volume Performance Statistics

Show Volume Reservations

Start Volume Initialization

Volume Copy Commands

Create Volume Copy

Recopy Volume Copy

Remove Volume Copy

Set Volume Copy

Show Volume Copy

Show Volume Copy Source Candidates

Show Volume Copy Target Candidates

Stop Volume Copy

Volume Group Commands

Create Volume Group

Delete Volume Group

Enable Volume Group Security

Revive Volume Group

Set Volume Group

Set Volume Group Forced State

Show Volume Group

Show Volume Group Export Dependencies

Show Volume Group Import Dependencies

Start Volume Group Defragment

Start Volume Group Export

Start Volume Group Import

Start Volume Group Locate

Stop Volume Group Locate

Commands Listed Alphabetically

Activate Host Port

This command activates an inactive host port that was created when the Host Context Agent (HCA) registered the host port to a host.

Syntax

```
activate hostPort "userLabel"
```

Parameters

| Parameter | Description |
|-----------|--|
| userLabel | The name of the HCA host port. Enclose the host port name in double quotation marks (" "). |

Minimum Firmware Level

7.50

Activate iSCSI Initiator

This command activates an inactive iSCSI initiator that was created when the Host Context Agent (HCA) registered the iSCSI initiator to a host.

Syntax

```
activate iscsiInitiator "iscsiID"
```

Parameters

| Parameter | Description |
|----------------|--|
| iscsiInitiator | The name of the iSCSI initiator. Enclose the name in double quotation marks (" "). |

Minimum Firmware Level

7.50

Activate Remote Volume Mirroring Feature

This command creates the mirror repository volume and activates the Remote Volume Mirroring premium feature. When you use this command, you can define the mirror repository volume in one of three ways:

- User-defined drives
- User-defined volume group
- User-defined number of drives

If you choose to define a number of drives, the controller firmware chooses which drives to use for the mirror repository volume.

Syntax (User-Defined Drives)

```
activate storageArray feature=remoteMirror
repositoryRAIDLevel=(1 | 3 | 5 | 6)
repositoryDrives=(trayID1,drawerID1,slotID1 ... trayIDn,drawerIDn,slotIDn)
repositoryVolumeGroupUserLabel=[volumeGroupName]
driveMediaType=(HDD | SSD | unknown | allMedia)
driveType=(fibre | SATA | SAS)
[trayLossProtect=(TRUE | FALSE)
drawerLossProtect=(TRUE | FALSE)
dataAssurance=(none | enabled)]
```

```
activate storageArray feature=remoteMirror
repositoryRAIDLevel=(1 | 3 | 5 | 6)
repositoryDrives=(trayID1,drawerID1,slotID1 ... trayIDn,drawerIDn,slotIDn)
repositoryVolumeGroupUserLabel=[volumeGroupName]
driveMediaType=(HDD | SSD | unknown | allMedia)
driveType=(fibre | SATA | SAS)
[trayLossProtect=(TRUE | FALSE)
drawerLossProtect=(TRUE | FALSE)
dataAssurance=(none | enabled)]
```

Syntax (User-Defined Volume Group)

```
activate storageArray feature=remoteMirror
repositoryVolumeGroup=volumeGroupName
[freeCapacityArea=freeCapacityIndexNumber]
```

Syntax (User-Defined Number of Drives)

```
activate storageArray feature=remoteMirror
repositoryRAIDLevel=(1 | 3 | 5 | 6)
repositoryDriveCount=numberOfDrives
repositoryVolumeGroupUserLabel=[volumeGroupName]
driveMediaType=(HDD | SSD | unknown | allMedia)
driveType=(fibre | SATA | SAS)]
[trayLossProtect=(TRUE | FALSE)
drawerLossProtect=(TRUE | FALSE)
dataAssurance=(none | enabled)]
```

```
activate storageArray feature=remoteMirror
repositoryRAIDLevel=(1 | 3 | 5 | 6)
repositoryDriveCount=numberOfDrives
repositoryVolumeGroupUserLabel=[volumeGroupName]
driveMediaType=(HDD | SSD | unknown | allMedia)
driveType=(fibre | SATA | SAS)]
[trayLossProtect=(TRUE | FALSE)
drawerLossProtect=(TRUE | FALSE)
dataAssurance=(none | enabled)]
```

Parameters

| Parameter | Description |
|--------------------------------|---|
| repositoryRAIDLevel | The RAID level for the mirror repository volume. Valid values are 1, 3, 5, or 6. |
| repositoryDrives | The drives for the mirror repository volume. For high-capacity drive trays, specify the tray ID value, the drawer ID value, and the slot ID value for each drive that you assign to the mirror repository volume. For low-capacity drive trays, specify the tray ID value and the slot ID value for each drive that you assign to the mirror repository volume. Tray ID values are 0 to 99. Drawer ID values are 1 to 5. Slot ID values are 1 to 32. Enclose the tray ID values, the drawer ID values, and the slot ID values in parentheses. |
| repositoryVolumeGroupUserLabel | The alphanumeric identifier (including - and _) that you want to give the new volume group in which the mirror repository volume will be located. Enclose the volume group identifier in square brackets ([]). |
| repositoryVolumeGroup | The name of the mirror repository volume group where the mirror repository volume is located. (To determine the names of the volume groups in your storage array, run the show storageArray profile command.) |
| driveMediaType | <p>The type of drive media that you want to use for the mirror repository volume group. Valid drive media are these:</p> <ul style="list-style-type: none"> ▪ HDD – Use this option when you have hard drives in the drive tray. ▪ SSD – Use this option when you have solid state drives in the drive tray. ▪ unknown – Use if you are not sure what types of drive media are in the drive tray. ▪ allMedia – Use this option when you want to use all types of drive media that are in the drive tray. <p>Use this parameter when you use the <code>repositoryDriveCount</code> parameter. You must use this parameter when you have more than one type of drive media in your storage array.</p> |
| driveType | <p>The type of drive that you want to use in the mirror volume. You cannot mix drive types. You must use this parameter when you have more than one type of drive in your storage array. Valid drive types are :</p> <ul style="list-style-type: none"> ▪ fibre ▪ SATA ▪ SAS |

| Parameter | Description |
|--|--|
| | <p>If you do not specify a drive type, the command defaults to fibre.</p> <p>Use this parameter when you use the <code>repositoryDriveCount</code> parameter.</p> |
| <p><code>freeCapacityArea</code></p> | <p>The index number of the free space in an existing volume group that you want to use to create the mirror repository volume. Free capacity is defined as the free capacity between existing volumes in a volume group. For example, a volume group might have the following areas: volume 1, free capacity, volume 2, free capacity, volume 3, free capacity. To use the free capacity following volume 2, you would specify:</p> <pre>freeCapacityArea=2</pre> <p>Run the <code>show volumeGroup</code> command to determine if a free capacity area exists.</p> |
| <p><code>repositoryDriveCount</code></p> | <p>The number of unassigned drives that you want to use for the mirror repository volume.</p> |
| <p><code>trayLossProtect</code></p> | <p>The setting to enforce tray loss protection when you create the mirror repository volume. To enforce tray loss protection, set this parameter to TRUE. The default value is FALSE.</p> |
| <p><code>drawerLossProtect</code></p> | <p>The setting to enforce drawer loss protection when you create the mirror repository volume. To enforce drawer loss protection, set this parameter to TRUE. The default value is FALSE.</p> |
| <p><code>dataAssurance</code></p> | <p>The setting to specify that a volume group, and the volumes within the volume group, has data assurance protection to make sure that the data maintains its integrity. When you use this parameter, only protected drives can be used for the volume group. These settings are valid:</p> <ul style="list-style-type: none"> ▪ none – The volume group does not have data assurance protection. ▪ enabled – The volume group has data assurance protection. The volume group supports protected information and is formatted with protection information enabled. |
| <p><code>dataAssurance</code></p> | <p>The setting to specify that a volume group, and the volumes within the volume group, has data assurance protection to make sure that the data maintains its integrity. When you use this parameter, only protected drives can be used for the volume group. These settings are valid:</p> <ul style="list-style-type: none"> ▪ none – The volume group does not have data assurance protection. |

| Parameter | Description |
|-----------|--|
| | <ul style="list-style-type: none"> ▪ enabled – The volume group has data assurance protection. The volume group supports protected information and is formatted with protection information enabled. |

Notes

The `repositoryDrives` parameter supports both high-capacity drive trays and low-capacity drive trays. A high-capacity drive tray has drawers that hold the drives. The drawers slide out of the drive tray to provide access to the drives. A low-capacity drive tray does not have drawers. For a high-capacity drive tray, you must specify the identifier (ID) of the drive tray, the ID of the drawer, and the ID of the slot in which a drive resides. For a low-capacity drive tray, you need only specify the ID of the drive tray and the ID of the slot in which a drive resides. For a low-capacity drive tray, an alternative method for identifying a location for a drive is to specify the ID of the drive tray, set the ID of the drawer to 0, and specify the ID of the slot in which a drive resides.

If the drives that you select for the `repositoryDrives` parameter are not compatible with other parameters (such as the `repositoryRAIDLevel` parameter), the script command returns an error, and Remote Volume Mirroring is not activated. The error returns the amount of space that is needed for the mirror repository volume. You can then re-enter the command, and specify the appropriate amount of space.

If you enter a value for the repository storage space that is too small for the mirror repository volumes, the controller firmware returns an error message that provides the amount of space that is needed for the mirror repository volumes. The command does not try to activate Remote Volume Mirroring. You can re-enter the command by using the value from the error message for the repository storage space value.

When you assign the drives, if you set the `trayLossProtect` parameter to **TRUE** and have selected more than one drive from any one tray, the storage array returns an error. If you set the `trayLossProtect` parameter to **FALSE**, the storage array performs operations, but the volume group that you create might not have tray loss protection.

When the controller firmware assigns the drives, if you set the `trayLossProtect` parameter to **TRUE**, the storage array returns an error if the controller firmware cannot provide drives that result in the new volume group having tray loss protection. If you set the `trayLossProtect` parameter to **FALSE**, the storage array performs the operation even if it means that the volume group might not have tray loss protection.

The `drawerLossProtect` parameter defines if data on a volume is accessible if a drawer fails. When you assign the drives, if you set the `drawerLossProtect` parameter to **TRUE** and select more than one drive from any one drawer, the storage array returns an error. If you set the `drawerLossProtect` parameter to **FALSE**, the storage array performs operations, but the volume group that you create might not have drawer loss protection.

You must set the `trayLossProtect` parameter and the `drawerLossProtect` parameter to the same value. Both of the parameters must be either **TRUE** or **FALSE**. If the `trayLossProtect` parameter and the `drawerLossProtect` parameter are set to different values, the storage array returns an error.

Minimum Firmware Level

6.10

7.10 adds RAID Level 6 capability.

7.60 adds the `drawerID` user input, the `driveMediaType` parameter, and the `drawerLossProtect` parameter.

7.75 adds the `dataAssurance` parameter.

Activate Storage Array Firmware

This command activates firmware that you have previously downloaded to the pending configuration area on the controllers in the storage array.

Syntax

```
activate storageArray firmware
```

Parameters

None.

Minimum Firmware Level

6.10

Autoconfigure Storage Array

This command automatically configures a storage array. Before you enter the **autoConfigure storageArray** command, run the **show storageArray autoConfiguration** command. The **show storageArray autoConfiguration** command returns configuration information in the form of a list of valid drive types, RAID levels, volume information, and hot spare information. (This list corresponds to the parameters for the **autoConfigure storageArray** command.) The controllers audit the storage array and then determine the highest RAID level that the storage array can support and the most efficient volume definition for the RAID level. If the configuration that is described by the returned list is acceptable, you can enter the **autoConfigure storageArray** command without any parameters. If you want to modify the configuration, you can change the parameters to meet your configuration requirements. You can change a single parameter or all of the parameters. After you enter the **autoConfigure storageArray** command, the controllers set up the storage array by using either the default parameters or those you selected.

Syntax

```
autoConfigure storageArray
driveType=(fibre | SATA | SAS)
raidLevel=(0 | 1 | 3 | 5 | 6)
volumeGroupWidth=numberOfDrives
volumeGroupCount=numberOfVolumeGroups
volumesPerGroupCount=numberOfVolumesPerGroup
hotSpareCount=numberOfHotSpares
segmentSize=segmentSizeValue
cacheReadPrefetch=(TRUE | FALSE)
securityType=(none | capable | enabled)
dataAssurance=(none | enabled)]
```

```
autoConfigure storageArray
driveType=(fibre | SATA | SAS)
raidLevel=(0 | 1 | 3 | 5 | 6)
volumeGroupWidth=numberOfDrives
volumeGroupCount=numberOfVolumeGroups
volumesPerGroupCount=numberOfVolumesPerGroup
```

```

hotSpareCount=numberOfHotSpares
segmentSize=segmentSizeValue
cacheReadPrefetch=(TRUE | FALSE)
securityType=(none | capable | enabled)
dataAssurance=(none | enabled)]

```

Parameters

| Parameter | Description |
|----------------------|--|
| driveType | The type of drives that you want to use for the storage array. You must use this parameter when you have more than one type of drive in your storage array. Valid drive types are : <ul style="list-style-type: none"> ▪ fibres ▪ SATA ▪ SAS If you do not specify a drive type, the command defaults to fibres . |
| raidLevel | The RAID level of the volume group that contains the drives in the storage array. Valid RAID levels are 0, 1, 3, 5, or 6. |
| volumeGroupWidth | The number of drives in a volume group in the storage array. |
| volumeGroupCount | The number of volume groups in the storage array. Use integer values. |
| volumesPerGroupCount | The number of equal-capacity volumes per volume group. Use integer values. |
| hotSpareCount | The number of hot spares that you want in the storage array. Use integer values. |
| segmentSize | The amount of data (in KB) that the controller writes on a single drive in a volume before writing data on the next drive. Valid values are 8, 16, 32, 64, 128, 256, or 512. |
| cacheReadPrefetch | The setting to turn on or turn off cache read prefetch. To turn off cache read prefetch, set this parameter to FALSE . To turn on cache read prefetch, set this parameter to TRUE . |
| securityType | The setting to specify the security level when creating the volume groups and all associated volumes. These settings are valid: <ul style="list-style-type: none"> ▪ none – The volume group and volumes are not secure. |

| Parameter | Description |
|---------------|--|
| | <ul style="list-style-type: none"> ▪ capable – The volume group and volumes are capable of having security set, but security has not been enabled. ▪ enabled – The volume group and volumes have security enabled. |
| dataAssurance | <p>The setting to specify that a volume group, and the volumes within the volume group, has data assurance protection to make sure that the data maintains its integrity. When you use this parameter, only protected drives can be used for the volume group. These settings are valid:</p> <ul style="list-style-type: none"> ▪ none – The volume group does not have data assurance protection. ▪ enabled – The volume group has data assurance protection. The volume group supports protected information and is formatted with protection information enabled. |
| dataAssurance | <p>The setting to specify that a volume group, and the volumes within the volume group, has data assurance protection to make sure that the data maintains its integrity. When you use this parameter, only protected drives can be used for the volume group. These settings are valid:</p> <ul style="list-style-type: none"> ▪ none – The volume group does not have data assurance protection. ▪ enabled – The volume group has data assurance protection. The volume group supports protected information and is formatted with protection information enabled. |

Notes

Drives and Volume Group

A volume group is a set of drives that are logically grouped together by the controllers in the storage array. The number of drives in a volume group is a limitation of the RAID level and the controller firmware. When you create a volume group, follow these guidelines:

- Beginning with firmware version 7.10, you can create an empty volume group so that you can reserve the capacity for later use.
- You cannot mix drive types, such as SAS, SATA and Fibre Channel, within a single volume group.
- The maximum number of drives in a volume group depends on these conditions:
 - The type of controller
 - The RAID level
- RAID levels include: 0, 1, 10, 3, 5, and 6.

- In a CDE3992 or a CDE3994 storage array, a volume group with RAID level 0 and a volume group with RAID level 10 can have a maximum of 112 drives.
- In a CE6998 storage array, a volume group with RAID level 0 and a volume group with RAID level 10 can have a maximum of 224 drives.
- A volume group with RAID level 3, RAID level 5, or RAID level 6 cannot have more than 30 drives.
- A volume group with RAID level 6 must have a minimum of five drives.
- If a volume group with RAID level 1 has four or more drives, the storage management software automatically converts the volume group to a RAID level 10, which is RAID level 1 + RAID level 0.
- If a volume group contains drives that have different capacities, the overall capacity of the volume group is based on the smallest capacity drive.
- To enable tray loss protection, you must create a volume group that uses drives located in at least three drive trays.

Hot Spares

Hot spare drives can replace any failed drive in the storage array. The hot spare must be the same type of drive as the drive that failed (that is, a SAS hot spare cannot replace a Fibre Channel drive). A hot spare must have capacity greater than or equal to any drive that can fail. If a hot spare is smaller than a failed drive, you cannot use the hot spare to rebuild the data from the failed drive. Hot spares are available only for RAID Level 1, RAID Level 3, RAID Level 5, or RAID Level 6.

Segment Size

The size of a segment determines how many data blocks that the controller writes on a single drive in a volume before writing data on the next drive. Each data block stores 512 bytes of data. A data block is the smallest unit of storage. The size of a segment determines how many data blocks that it contains. For example, an 8-KB segment holds 16 data blocks. A 64-KB segment holds 128 data blocks.

When you enter a value for the segment size, the value is checked against the supported values that are provided by the controller at run time. If the value that you entered is not valid, the controller returns a list of valid values. Using a single drive for a single request leaves other drives available to simultaneously service other requests.

If the volume is in an environment where a single user is transferring large units of data (such as multimedia), performance is maximized when a single data transfer request is serviced with a single data stripe. (A data stripe is the segment size that is multiplied by the number of drives in the volume group that are used for data transfers.) In this case, multiple drives are used for the same request, but each drive is accessed only once. For optimal performance in a multiuser database or file system storage environment, set your segment size to minimize the number of drives that are required to satisfy a data transfer request.

Cache Read Prefetch

Cache read prefetch lets the controller copy additional data blocks into cache while the controller reads and copies data blocks that are requested by the host from the drive into cache. This action increases the chance that a future request for data can be fulfilled from cache. Cache read prefetch is important for multimedia applications that use sequential data transfers. The configuration settings for the storage array that you use determine the number of additional data blocks that the controller reads into cache. Valid values for the `cacheReadPrefetch` parameter are **TRUE** or **FALSE**.

Security Type

The `securityType` parameter is valid for drives that are capable of full disk encryption (FDE). With FDE, the controller firmware can create a key and activate the drive security feature. The drive security feature encrypts data as the data is written to the drive and decrypts the data as the data is read from the drive. Without the key created by the controller, the data written to the drive is inaccessible.

Before you can set the `securityType` parameter to **capable** or **enabled**, you must create a storage array security key. Use the `create storageArray securityKey` command to create a storage array security key. These commands are related to the security key:

- `create storageArray securityKey`
- `set storageArray securityKey`
- `import storageArray securityKey`
- `export storageArray securityKey`
- `start secureErase (drive | drives)`
- `enable volumeGroup [volumeGroupName] security`

Minimum Firmware Level

6.10

7.10 adds RAID Level 6 capability and removes hot spare limits.

7.50 adds the `securityType` parameter.

7.75 adds the `dataAssurance` parameter.

Autoconfigure Storage Array Hot Spares

This command automatically defines and configures the hot spares in a storage array. You can run this command at any time. This command provides the best hot spare coverage for a storage array.

Syntax

```
autoConfigure storageArray hotSpares
```

Parameters

None.

Notes

When you run the `autoconfigure storageArray hotSpares` command, the controller firmware determines the number of hot spares to create based on the total number and type of drives in the storage array. For Fibre Channel drives, SATA drives, and SAS drives, the controller firmware creates one hot spare for the storage array and one additional hot spare for every 60 drives in the storage array.

Minimum Firmware Level

6.10

Check Remote Mirror Status

This command returns the status of a remote-mirror volume. Use this command to determine when the status of the remote-mirror volume becomes Optimal.

Syntax

```
check remoteMirror localVolume [volumeName] optimalStatus timeout=timeoutValue
```

Parameters

| Parameter | Description |
|-------------|---|
| localVolume | The name of any remote-mirror volume. The remote-mirror volume can be the primary volume or the secondary volume of a remote mirrored pair. Enclose the volume name in square brackets ([]). If the volume name has special characters, you also must enclose the volume name in double quotation marks (" "). |
| timeout | The time interval within which the software can return the remote-mirror volume status. The timeout value is in minutes. |

Notes

This command waits until the status becomes Optimal or the timeout interval expires. Use this command when you run the Asynchronous Remote Volume Mirroring utility.

For more information, see the topic "Asynchronous Remote Volume Mirroring Utility."

Minimum Firmware Level

6.10

Check Volume Parity

This command checks a volume for parity and media errors and writes the results of the check to a file.

Syntax

```
check volume [volumeName]
parity [parityErrorFile=filename]
[mediaErrorFile=filename]
[priority=(highest | high | medium | low | lowest)]
[startingLBA=LBValue] [endingLBA=LBValue]
[verbose=(TRUE | FALSE)]
```

Parameters

| Parameter | Description |
|-----------------|---|
| volume | The name of the specific volume for which you want to check parity. Enclose the volume name in square brackets ([]). If the volume name has special characters, you also must enclose the volume name in double quotation marks (" "). |
| parityErrorFile | The file path and the file name to which you want to save the parity error information. Enclose the file name in double quotation marks (" "). For example: file="C:\Program Files\CLI\logs\parerr.txt" This command does not automatically append a file extension to the saved file. You must specify a file extension when entering the file name. |
| mediaErrorFile | The file path and the file name to which you want to save the media error information. Enclose the file name in double quotation marks (" "). For example: file="C:\Program Files\CLI\logs\mederr.txt" This command does not automatically append a file extension to the saved file. You must specify a file extension when entering the file name. |
| priority | The priority that the parity check has relative to host I/O activity. Valid values are highest , high , medium , low , or lowest . |
| startingLBA | The starting logical block address. Use integer values. |
| endingLBA | The ending logical block address. Use integer values. |
| verbose | The setting to capture progress details, such as percent complete, and to show the information as the volume parity is being repaired. To capture progress details, set this parameter to TRUE . To prevent capturing progress details, set this parameter to FALSE . |

Notes

The starting logical block address and the ending logical block address are useful for very large single-volume LUNs. Running a volume parity check on a very large single volume LUN can take a long time. By defining the beginning address and ending address of the data blocks, you can reduce the time that a volume parity check takes to complete.

Minimum Firmware Level

6.10

Clear Drive Channel Statistics

This command resets the statistics for all of the drive channels.

Syntax

```
clear all DriveChannels stats
```

Parameters

None.

Minimum Firmware Level

6.10

Clear Storage Array Configuration

Use this command to perform one of these operations:

- Clear the entire storage array configuration, and return it back to the initial installation state
- Clear the configuration except for security information and identification information
- Clear volume group configuration information and volume configuration information only



ATTENTION Possible damage to the storage array configuration – As soon as you run this command, the existing storage array configuration is deleted.

Syntax

```
clear storageArray configuration [all | volumeGroups]
```

Parameters

| Parameter | Description |
|--------------|--|
| None | If you do not enter a parameter, this command removes all configuration information for the storage array, except for information related to security and identification. |
| all | The setting to remove the entire configuration of the storage array, including security information and identification information. Removing all configuration information returns the storage array to its initial state. |
| volumeGroups | The setting to remove the volume configuration and the volume group configuration. The rest of the configuration stays intact. |

Notes

When you run this command, the storage array becomes unresponsive, and all script processing is canceled. You must remove and re-add the storage array to resume communication with the host. To remove an unresponsive storage array, access the Enterprise Management Window, and select **Edit > Remove**. To re-add the storage array, access the Enterprise Management Window, select **Edit > Add Storage Array**, and enter the appropriate IP addresses.

Minimum Firmware Level

6.10

7.10 adds these parameters:

- all
- volumeGroups

Clear Storage Array Event Log

This command clears the Event Log in the storage array by deleting the data in the Event Log buffer.



ATTENTION Possible damage to the storage array configuration – As soon as you run this command, the existing Event Log in the storage array is deleted.

Syntax

```
clear storageArray eventLog
```

Parameters

None.

Minimum Firmware Level

6.10

Clear Storage Array Firmware Pending Area

This command deletes a firmware image or NVSRAM values that you have previously downloaded from the pending area buffer.



ATTENTION Possible damage to the storage array configuration – As soon as you run this command, the contents of the existing pending area in the storage array are deleted.

Syntax

```
clear storageArray firmwarePendingArea
```

Parameters

None.

Minimum Firmware Level

6.10

Clear Volume Reservations

This command clears persistent volume reservations.

Syntax

```
clear (allVolumes | volume [volumeName] |
volumes [volumeName1 ... volumeNameN]) reservations
```

Parameters

| Parameter | Description |
|-------------------|--|
| allVolumes | The setting to clear persistent volume reservations on all of the volumes in the storage array. |
| volume or volumes | The name of the specific volume for which you want to clear persistent volume reservations. You can enter more than one volume name. Enclose the volume name in square brackets ([]). If the volume name has special characters, you also must enclose the volume name in double quotation marks (" "). |

Notes

You can use any combination of alphanumeric characters, hyphens, and underscores for the names. Names can have a maximum of 30 characters.

Minimum Firmware Level

5.40

Clear Volume Unreadable Sectors

This command clears unreadable sector information from one or more volumes.

Syntax

```
clear (allVolumes | volume [volumeName] |
volumes [volumeName1 ... volumeNameN]) unreadableSectors
```

Parameters

| Parameter | Description |
|-------------------|---|
| allVolumes | The setting to clear unreadable sector information from all of the volumes in the storage array. |
| volume or volumes | The name of the specific volume for which you want to clear unreadable sector information. You can enter more than one volume name. Enclose the volume name in square brackets ([]). If the volume name has special characters, you also must enclose the volume name in double quotation marks (" "). |

Notes

You can use any combination of alphanumeric characters, hyphens, and underscores for the names. Names can have a maximum of 30 characters.

Minimum Firmware Level

6.10

Create Host

This command creates a new host. If you do not specify a host group in which to create the new host, the new host is created in the Default Group.

Syntax

```
create host userLabel="hostName"
[hostGroup=("hostGroupName" | defaultGroup)]
[hostType=(hostTypeIndexLabel | hostTypeIndexNumber)]
```

Parameters

| Parameter | Description |
|-----------|--|
| userLabel | The name that you want to give the host that you are creating. Enclose the host name in double quotation marks (" "). |
| hostGroup | The name of the host group in which you want to create a new host. Enclose the host group name in double quotation marks (" "). (If a host group does not exist, you can create a new host group by using the create hostGroup command.) The defaultGroup option is the host group that contains the host to which the volume is mapped. |
| hostType | The index label or the index number that identifies the host type. Use the show storageArray hostTypeTable command to generate a list of available host type identifiers. If the host type has special characters, enclose the host type in double quotation marks (" "). |

Notes

You can use any combination of alphanumeric characters, hyphens, and underscores for the names. Names can have a maximum of 30 characters.

A host is a computer that is attached to the storage array and accesses the volumes on the storage array through the host ports. You can define specific mappings to an individual host. You also can assign the host to a host group that shares access to one or more volumes.

A host group is an optional topological element that you can define if you want to designate a collection of hosts that share access to the same volumes. The host group is a logical entity. Define a host group only if you have two or more hosts that share access to the same volumes.

If you do not specify a host group in which to place the host that you are creating, the newly defined host belongs to the default host group.

Minimum Firmware Level

5.20

7.10 adds the `hostType` parameter.

Create Host Group

This command creates a new host group.

Syntax

```
create hostGroup userLabel="hostGroupName"
```

Parameter

| Parameter | Description |
|------------------------|---|
| <code>userLabel</code> | The name that you want to give the host group that you are creating. Enclose the host name in double quotation marks (" "). |

Notes

A host group is an optional topological element that you can define if you want to designate a collection of hosts that share access to the same volumes. The host group is a logical entity. Define a host group only if you have two or more hosts that can share access to the same volumes.

You can use any combination of alphanumeric characters, hyphens, and underscores for the names. Names can have a maximum of 30 characters.

Minimum Firmware Level

5.20

Create Host Port

This command creates a new host port identification on a host bus adapter (HBA) or on a host channel adapter (HCA). The identification is a software value that represents the physical HBA or HCA host port to the controller. Without the correct host port identification, the controller cannot receive instructions or data from the host port.

Syntax

```
create hostPort identifier=("wwID" | "gid")
userLabel="portLabel"
host="hostName"
interfaceType=(FC | SAS | IB)
```

Parameters

| Parameter | Description |
|-------------------------|---|
| <code>identifier</code> | The 8-byte World Wide Identifier (WWID) or the 16-byte group identifier (GID) of the HBA or HCA host port. Enclose the WWID or the GID in double quotation marks (" "). |

| Parameter | Description |
|---------------|--|
| userLabel | The name that you want to give to the new HBA or HCA host port. Enclose the host port label in double quotation marks (" "). |
| host | The name of the host for which you are defining an HBA or HCA host port. Enclose the host name in double quotation marks (" "). |
| interfaceType | The identifier of the type of interface for the host port. The choices for the types of host port interfaces are: <ul style="list-style-type: none"> ▪ FC – Fibre Channel ▪ SAS – Serial-Attached SCSI ▪ IB – Infiniband An FC or a SAS selection requires an 8-byte WWID. An IB selection requires a 16-byte group identifier (gid). If you do not specify the type of interface, FC is used as the default interface for the host port. |

Notes

An HBA host port or an HCA host port is a physical connection on a host bus adapter or on a host channel adapter that resides in a host computer. An HBA host port or an HCA host port provides host access to the volumes in a storage array. If the HBA or the HCA has only one physical connection (one host port), the terms host port and host bus adapter or host channel adapter are synonymous.

You can use any combination of alphanumeric characters, hyphens, and underscores for the names. Names can have a maximum of 30 characters.

Minimum Firmware Level

5.20

7.10 deprecates the `hostType` parameter. The `hostType` parameter has been added to the **create host** command.

7.32 adds the `interfaceType` parameter.

Create iSCSI Initiator

This command creates a new iSCSI initiator object.

Syntax

```
create iscsiInitiator iscsiName="iscsiID"
userLabel="name"
host="hostName"
[chapSecret="securityKey"]
```

Parameters

| Parameters | Description |
|-------------------------|--|
| <code>iscsiName</code> | The default identifier of the iSCSI initiator. Enclose the identifier in double quotation marks (" "). |
| <code>userLabel</code> | The name that you want to use for the iSCSI initiator. Enclose the name in double quotation marks (" "). |
| <code>host</code> | The name of the host in which the iSCSI initiator is installed. Enclose the name in double quotation marks (" "). |
| <code>chapSecret</code> | The security key that you want to use to authenticate a peer connection. Enclose the security key in double quotation marks (" "). |

Notes

Challenge Handshake Authentication Protocol (CHAP) is a protocol that authenticates the peer of a connection. CHAP is based upon the peers sharing a *secret*. A secret is a security key that is similar to a password.

Use the `chapSecret` parameter to set up the security keys for initiators that require a mutual authentication.

Minimum Firmware Level

7.10

Create RAID Volume (Automatic Drive Select)

This command creates a volume group across the drives in the storage array and a new volume in the volume group. The storage array controllers choose the drives to be included in the volume.



NOTE If you have drives with different capacities, you cannot automatically create volumes by specifying the `driveCount` parameter. If you want to create volumes with drives of different capacities, see ["Create RAID Volume \(Manual Drive Select\)."](#)

Syntax

```
create volume driveCount=numberOfDrives
volumeGroupUserLabel="volumeGroupName"
raidLevel=(0 | 1 | 3 | 5 | 6)
userLabel="volumeName"
driveMediaType=(HDD | SSD | unknown | allMedia)
[driveType=(fibre | SATA | SAS)
capacity=volumeCapacity
owner=(a | b)
cacheReadPrefetch=(TRUE | FALSE)
segmentSize=segmentSizeValue
usageHint=(fileSystem | dataBase | multiMedia)
trayLossProtect=(TRUE | FALSE)
drawerLossProtect=(TRUE | FALSE)
dssPreAllocate=(TRUE | FALSE)
```

```

securityType=(none | capable | enabled)
dataAssurance=(none | enabled)]

create volume driveCount=numberOfDrives
volumeGroupUserLabel="volumeGroupName"
raidLevel=(0 | 1 | 3 | 5 | 6)
userLabel="volumeName"
driveMediaType=(HDD | SSD | unknown | allMedia)
[driveType=(fibre | SATA | SAS)
capacity=volumeCapacity
owner=(a | b)
cacheReadPrefetch=(TRUE | FALSE)
segmentSize=segmentSizeValue
usageHint=(fileSystem | dataBase | multiMedia)
trayLossProtect=(TRUE | FALSE)
drawerLossProtect=(TRUE | FALSE)
dssPreAllocate=(TRUE | FALSE)
securityType=(none | capable | enabled)
dataAssurance=(none | enabled)]

```

Parameters

| Parameter | Description |
|----------------------|---|
| driveCount | The number of unassigned drives that you want to use in the volume group. |
| volumeGroupUserLabel | The alphanumeric identifier (including – and _) that you want to give the new volume group. Enclose the new volume group name in double quotation marks (" "). |
| raidLevel | The RAID level of the volume group that contains the volume. Valid values are 0, 1, 3, 5, or 6. |
| userLabel | The name that you want to give to the new volume. Enclose the new volume name in double quotation marks (" "). |
| driveMediaType | The type of drive media that you want to use for the volume group. Valid drive media are these: <ul style="list-style-type: none"> ▪ HDD – Use this option when you have hard drives in the drive tray. ▪ SSD – Use this option when you have solid state drives in the drive tray. ▪ unknown – Use if you are not sure what types of drive media are in the drive tray. ▪ allMedia – Use this option when you want to use all types of drive media that are in the drive tray. |
| driveType | The type of drive that you want to use in the volume. You cannot mix drive types. You must use this parameter when you have more than one type of drive in your storage array. |

| Parameter | Description |
|-------------------|---|
| | <p>Valid drive types are :</p> <ul style="list-style-type: none"> ▪ ibre ▪ SATA ▪ SAS <p>If you do not specify a drive type, the command defaults to ibre.</p> |
| capacity | The size of the volume that you are adding to the storage array. Size is defined in units of bytes , KB , MB , GB , or TB . |
| owner | The controller that owns the volume. Valid controller identifiers are a or b , where a is the controller in slot A, and b is the controller in slot B. If you do not specify an owner, the controller firmware determines the owner. |
| cacheReadPrefetch | The setting to turn on or turn off cache read prefetch. To turn off cache read prefetch, set this parameter to FALSE . To turn on cache read prefetch, set this parameter to TRUE . |
| segmentSize | The amount of data (in KB) that the controller writes on a single drive in a volume before writing data on the next drive. Valid values are 8 , 16 , 32 , 64 , 128 , 256 , or 512 . |
| usageHint | The setting for both <code>cacheReadPrefetch</code> parameter and the <code>segmentSize</code> parameter to be default values. The default values are based on the typical I/O usage pattern of the application that is using the volume. Valid values are fileSystem , dataBase , or multiMedia . |
| trayLossProtect | The setting to enforce tray loss protection when you create the volume group. To enforce tray loss protection, set this parameter to TRUE . The default value is FALSE . |
| drawerLossProtect | The setting to enforce drawer loss protection when you create the mirror repository volume group. To enforce drawer loss protection, set this parameter to TRUE . The default value is FALSE . |
| dssPreAllocate | The setting to make sure that reserve capacity is allocated for future segment size increases. The default value is TRUE . |
| securityType | <p>The setting to specify the security level when creating the volume groups and all associated volumes. These settings are valid:</p> <ul style="list-style-type: none"> ▪ none – The volume group and volumes are not secure. ▪ capable – The volume group and volumes are capable of having security set, but security has not been enabled. |

| Parameter | Description |
|---------------|--|
| | <ul style="list-style-type: none"> ▪ enabled – The volume group and volumes have security enabled. |
| dataAssurance | <p>The setting to specify that a volume group, and the volumes within the volume group, has data assurance protection to make sure that the data maintains its integrity. When you use this parameter, only protected drives can be used for the volume group. These settings are valid:</p> <ul style="list-style-type: none"> ▪ none – The volume group does not have data assurance protection. ▪ enabled – The volume group has data assurance protection. The volume group supports protected information and is formatted with protection information enabled. |
| dataAssurance | <p>The setting to specify that a volume group, and the volumes within the volume group, has data assurance protection to make sure that the data maintains its integrity. When you use this parameter, only protected drives can be used for the volume group. These settings are valid:</p> <ul style="list-style-type: none"> ▪ none – The volume group does not have data assurance protection. ▪ enabled – The volume group has data assurance protection. The volume group supports protected information and is formatted with protection information enabled. |

Notes

You can use any combination of alphanumeric characters, hyphens, and underscores for the names. Names can have a maximum of 30 characters.

The `driveCount` parameter lets you choose the number of drives that you want to use in the volume group. You do not need to specify the drives by tray ID and slot ID. The controllers choose the specific drives to use for the volume group.

The `owner` parameter defines which controller owns the volume.

If you do not specify a capacity using the `capacity` parameter, all of the drive capacity that is available in the volume group is used. If you do not specify capacity units, **bytes** is used as the default value.

Cache Read Prefetch

Cache read prefetch lets the controller copy additional data blocks into cache while the controller reads and copies data blocks that are requested by the host from the drives into cache. This action increases the chance that a future request for data can be fulfilled from cache. Cache read prefetch is important for multimedia applications that use sequential data transfers. The configuration settings for the storage array that you use determine the number of additional data blocks that the controller reads into cache. Valid values for the `cacheReadPrefetch` parameter are **TRUE** or **FALSE**.

Segment Size

The size of a segment determines how many data blocks that the controller writes on a single drive in a volume before writing data on the next drive. Each data block stores 512 bytes of data. A data block is the smallest unit of storage. The size of a segment determines how many data blocks that it contains. For example, an 8-KB segment holds 16 data blocks. A 64-KB segment holds 128 data blocks.

When you enter a value for the segment size, the value is checked against the supported values that are provided by the controller at run time. If the value that you entered is not valid, the controller returns a list of valid values. Using a single drive for a single request leaves other drives available to simultaneously service other requests.

If the volume is in an environment where a single user is transferring large units of data (such as multimedia), performance is maximized when a single data transfer request is serviced with a single data stripe. A data stripe is the segment size that is multiplied by the number of drives in the volume group that are used for data transfers. In this case, multiple drives are used for the same request, but each drive is accessed only once.

For optimal performance in a multiuser database or file system storage environment, set your segment size to minimize the number of drives that are required to satisfy a data transfer request.

You do not need to enter a value for the `cacheReadPrefetch` parameter or the `segmentSize` parameter. If you do not enter a value, the controller firmware uses the `usageHint` parameter with `fileSystem` as the default value. Entering a value for the `usageHint` parameter and a value for the `cacheReadPrefetch` parameter or a value for the `segmentSize` parameter does not cause an error. The value that you enter for the `cacheReadPrefetch` parameter or the `segmentSize` parameter takes priority over the value for the `usageHint` parameter.

Tray Loss Protection and Drawer Loss Protection

For tray loss protection to work, each drive in a volume group must be on a separate tray. If you set the `trayLossProtect` parameter to **TRUE** and have selected more than one drive from any one tray, the storage array returns an error. If you set the `trayLossProtect` parameter to **FALSE**, the storage array performs operations, but the volume group that you create might not have tray loss protection.

Tray loss protection is not valid when you create volumes on existing volume groups.

The `drawerLossProtect` parameter defines if data on a volume is accessible if a drawer fails. When you assign the drives, if you set the `drawerLossProtect` parameter to **TRUE** and select more than one drive from any one drawer, the storage array returns an error. If you set the `drawerLossProtect` parameter to **FALSE**, the storage array performs operations, but the volume group that you create might not have drawer loss protection.

You must set the `trayLossProtect` parameter and the `drawerLossProtect` parameter to the same value. Both of the parameters must be either **TRUE** or **FALSE**. If the `trayLossProtect` parameter and the `drawerLossProtect` parameter are set to different values, the storage array returns an error.

Security Type

The `securityType` parameter is valid for drives that are capable of full disk encryption (FDE). With FDE, the controller firmware can create a key and activate the drive security feature. The drive security feature encrypts data as the data is written to the drive and decrypts the data as the data is read from the drive. Without the key created by the controller, the data written to the drive is inaccessible.

Before you can set the `securityType` parameter to **capable** or **enabled**, you must create a storage array security key. Use the **create storageArray securityKey** command to create a storage array security key. These commands are related to the security key:

- **create storageArray securityKey**
- **set storageArray securityKey**
- **import storageArray securityKey**
- **export storageArray securityKey**
- **start secureErase (drive | drives)**
- **enable volumeGroup [volumeGroupName] security**

Minimum Firmware Level

5.20

7.10 adds RAID Level 6 capability and the `dssPreAllocate` parameter.

7.50 adds the `securityType` parameter.

7.60 adds the `drawerLossProtect` parameter.

7.75 adds the `dataAssurance` parameter.

Create RAID Volume (Free Extent Based Select)

This command creates a volume in the free space of a volume group.

Syntax

```
create volume volumeGroup="volumeGroupName"
userLabel="volumeName"
[freeCapacityArea=freeCapacityIndexNumber
capacity=volumeCapacity
owner=(a | b)
cacheReadPrefetch=(TRUE | FALSE)
segmentSize=segmentSizeValue
usageHint=(fileSystem | dataBase | multiMedia)]
[dssPreAllocate=(TRUE | FALSE)
securityType=(none | capable | enabled)
dataAssurance=(none | enabled)]
```

```
create volume volumeGroup="volumeGroupName"
userLabel="volumeName"
[freeCapacityArea=freeCapacityIndexNumber
capacity=volumeCapacity
owner=(a | b)
cacheReadPrefetch=(TRUE | FALSE)
segmentSize=segmentSizeValue
usageHint=(fileSystem | dataBase | multiMedia)]
[dssPreAllocate=(TRUE | FALSE)
securityType=(none | capable | enabled)
dataAssurance=(none | enabled)]
```

Parameters

| Parameter | Description |
|-------------------|---|
| volumeGroup | The alphanumeric identifier (including - and _) for a specific volume group in your storage array. Enclose the volume group name in double quotation marks (" "). |
| userLabel | The name that you want to give the new volume. Enclose the new volume name in double quotation marks (" "). |
| freeCapacityArea | The index number of the free space in an existing volume group that you want to use to create the new volume. Free capacity is defined as the free capacity between existing volumes in a volume group. For example, a volume group might have the following areas: volume 1, free capacity, volume 2, free capacity, volume 3, free capacity. To use the free capacity following volume 2, you would enter this index number: freeCapacityArea=2 Run the show volumeGroup command to determine whether the free capacity area exists. |
| capacity | The size of the volume that you are adding to the storage array. Size is defined in units of bytes , KB , MB , GB , or TB . |
| owner | The controller that owns the volume. Valid controller identifiers are a or b , where a is the controller in slot A, and b is the controller in slot B. If you do not specify an owner, the controller firmware determines the owner. |
| cacheReadPrefetch | The setting to turn on or turn off cache read prefetch. To turn on cache read prefetch, set this parameter to TRUE . To turn off cache read prefetch, set this parameter to FALSE . |
| segmentSize | The amount of data (in KB) that the controller writes on a single drive in a volume before writing data on the next drive. Valid values are 8 , 16 , 32 , 64 , 128 , 256 , or 512 . |
| usageHint | The settings for both the <code>cacheReadPrefetch</code> parameter and the <code>segmentSize</code> parameter to be default values. The default values are based on the typical I/O usage pattern of the application that is using the volume. Valid values are fileSystem , dataBase , or multiMedia . |
| dssPreAllocate | The setting to make sure that reserve capacity is allocated for future segment size increases. The default value is TRUE . |
| securityType | The setting to specify the security level when creating the volume groups and all associated volumes. These settings are valid: none – The volume group and volumes are not secure. |

| Parameter | Description |
|---------------|--|
| | <p>capable – The volume group and volumes are capable of having security set, but security has not been enabled.</p> <p>enabled – The volume group and volumes have security enabled.</p> |
| dataAssurance | <p>The setting to specify that a volume group, and the volumes within the volume group, has data assurance protection to make sure that the data maintains its integrity. When you use this parameter, only protected drives can be used for the volume group. These settings are valid:</p> <ul style="list-style-type: none"> ▪ none – The volume group does not have data assurance protection. ▪ enabled – The volume group has data assurance protection. The volume group supports protected information and is formatted with protection information enabled. |
| dataAssurance | <p>The setting to specify that a volume group, and the volumes within the volume group, has data assurance protection to make sure that the data maintains its integrity. When you use this parameter, only protected drives can be used for the volume group. These settings are valid:</p> <ul style="list-style-type: none"> ▪ none – The volume group does not have data assurance protection. ▪ enabled – The volume group has data assurance protection. The volume group supports protected information and is formatted with protection information enabled. |

Notes

You can use any combination of alphanumeric characters, hyphens, and underscores for the names. Names can have a maximum of 30 characters.

The `owner` parameter defines which controller owns the volume. The preferred controller ownership of a volume is the controller that currently owns the volume group.

If you do not specify a capacity using the `capacity` parameter, all of the available capacity in the free capacity area of the volume group is used. If you do not specify capacity units, `bytes` is used as the default value.

Segment Size

The size of a segment determines how many data blocks that the controller writes on a single drive in a volume before writing data on the next drive. Each data block stores 512 bytes of data. A data block is the smallest unit of storage. The size of a segment determines how many data blocks that it contains. For example, an 8-KB segment holds 16 data blocks. A 64-KB segment holds 128 data blocks.

When you enter a value for the segment size, the value is checked against the supported values that are provided by the controller at run time. If the value that you entered is not valid, the controller returns a list of valid values. Using a single drive for a single request leaves other drives available to simultaneously service other requests.

If the volume is in an environment where a single user is transferring large units of data (such as multimedia), performance is maximized when a single data transfer request is serviced with a single data stripe. A data stripe is the segment size that is multiplied by the number of drives in the volume group that are used for data transfers. In this case, multiple drives are used for the same request, but each drive is accessed only once.

For optimal performance in a multiuser database or file system storage environment, set your segment size to minimize the number of drives that are required to satisfy a data transfer request.

Cache Read Prefetch

Cache read prefetch lets the controller copy additional data blocks into cache while the controller reads and copies data blocks that are requested by the host from the drives into cache. This action increases the chance that a future request for data can be fulfilled from cache. Cache read prefetch is important for multimedia applications that use sequential data transfers. The configuration settings for the storage array that you use determine the number of additional data blocks that the controller reads into cache. Valid values for the `cacheReadPrefetch` parameter are **TRUE** or **FALSE**. You do not need to enter a value for the `cacheReadPrefetch` parameter or the `segmentSize` parameter. If you do not enter a value, the controller firmware uses the `usageHint` parameter with **fileSystem** as the default value.

Entering a value for the `usageHint` parameter and a value for the `cacheReadPrefetch` parameter or a value for the `segmentSize` parameter does not cause an error. The value that you enter for the `cacheReadPrefetch` parameter or the `segmentSize` parameter takes priority over the value for the `usageHint` parameter.

Security Type

The `securityType` parameter is valid for drives that are capable of full disk encryption (FDE). With FDE, the controller firmware can create a key and activate the drive security feature. The drive security feature encrypts data as the data is written to the drive and decrypts the data as the data is read from the drive. Without the key created by the controller, the data written to the drive is inaccessible.

Before you can set the `securityType` parameter to **capable** or **enabled**, you must create a storage array security key. Use the `create storageArray securityKey` command to create a storage array security key. These commands are related to the security key:

- `create storageArray securityKey`
- `set storageArray securityKey`
- `import storageArray securityKey`
- `export storageArray securityKey`
- `start secureErase (drive | drives)`
- `enable volumeGroup [volumeGroupName] security`
- `create hostPort identifier`

Minimum Firmware Level

5.20

7.10 adds the `dssPreAllocate` parameter.

7.50 adds the `securityType` parameter.

7.75 adds the `dataAssurance` parameter.

Create RAID Volume (Manual Drive Select)

This command creates a new volume group and volume and lets you specify the drives for the volume.

 **NOTE** You cannot use mixed drive types in the same volume group and volume. This command fails if you specify different types of drives for the RAID volume.

Syntax

```
create volume drives=(trayID1,drawerID1,slotID1 ... trayIDn,drawerIDn,slotIDn)
volumeGroupUserLabel="volumeGroupName"
raidLevel=(0 | 1 | 3 | 5 | 6)
userLabel="volumeName"
[capacity=volumeCapacity
owner=(a | b)
cacheReadPrefetch=(TRUE | FALSE)
segmentSize=segmentSizeValue
usageHint=(fileSystem | dataBase | multiMedia)
trayLossProtect=(TRUE | FALSE)
drawerLossProtect=(TRUE | FALSE)
dssPreAllocate=(TRUE | FALSE)
securityType=(none | capable | enabled)
dataAssurance=(none | enabled)]
```

```
create volume drives=(trayID1,drawerID1,slotID1 ... trayIDn,drawerIDn,slotIDn)
volumeGroupUserLabel="volumeGroupName"
raidLevel=(0 | 1 | 3 | 5 | 6)
userLabel="volumeName"
[capacity=volumeCapacity
owner=(a | b)
cacheReadPrefetch=(TRUE | FALSE)
segmentSize=segmentSizeValue
usageHint=(fileSystem | dataBase | multiMedia)
trayLossProtect=(TRUE | FALSE)
drawerLossProtect=(TRUE | FALSE)
dssPreAllocate=(TRUE | FALSE)
securityType=(none | capable | enabled)
dataAssurance=(none | enabled)]
```

Parameters

| Parameter | Description |
|-----------|--|
| drives | The drives that you want to assign to the volume that you want to create. For high-capacity drive trays, specify the tray ID value, the drawer ID value, and the slot ID value for each drive that you assign to the volume. For low-capacity drive trays, specify the tray ID value and the slot ID value for each drive that you assign to the volume. |

| Parameter | Description |
|----------------------|--|
| | Tray ID values are 0 to 99. Drawer ID values are 1 to 5. Slot ID values are 1 to 32. Enclose the tray ID values, the drawer ID values, and the slot ID values in parentheses. |
| volumeGroupUserLabel | The alphanumeric identifier (including – and _) that you want to give the new volume group. Enclose the volume group identifier in double quotation marks (" "). |
| raidLevel | The RAID level of the volume group that contains the volume. Valid values are 0, 1, 3, 5, or 6. |
| userLabel | The name that you want to give the new volume. Enclose the new volume name in double quotation marks (" "). |
| capacity | The size of the volume that you are adding to the storage array. Size is defined in units of bytes , KB , MB , GB , or TB . |
| owner | The controller that owns the volume. Valid controller identifiers are a or b , where a is the controller in slot A, and b is the controller in slot B. If you do not specify an owner, the controller firmware determines the owner. |
| cacheReadPrefetch | The setting to turn on or turn off cache read prefetch. To turn off cache read prefetch, set this parameter to FALSE . To turn on cache read prefetch, set this parameter to TRUE . |
| segmentSize | The amount of data (in KB) that the controller writes on a single drive in a volume before writing data on the next drive. Valid values are 8, 16, 32, 64, 128, 256, or 512. |
| usageHint | The settings for both the <code>cacheReadPrefetch</code> parameter and the <code>segmentSize</code> parameter to be default values. The default values are based on the typical I/O usage pattern of the application that is using the volume. Valid values are fileSystem , dataBase , or multiMedia . |
| trayLossProtect | The setting to enforce tray loss protection when you create the repository. To enforce tray loss protection, set this parameter to TRUE . The default value is FALSE . |
| drawerLossProtect | The setting to enforce drawer loss protection when you create the mirrored repository volume. To enforce drawer loss protection, set this parameter to TRUE . The default value is FALSE . |
| dssPreAllocate | The setting to make sure that reserve capacity is allocated for future segment size increases. This default value is TRUE . |

| Parameter | Description |
|---------------|--|
| securityType | <p>The setting to specify the security level when creating the volume groups and all associated volumes. These settings are valid:</p> <ul style="list-style-type: none"> ▪ none – The volume group and volumes are not secure. ▪ capable – The volume group and volumes are capable of having security set, but security has not been enabled. ▪ enabled – The volume group and volumes have security enabled. |
| dataAssurance | <p>The setting to specify that a volume group, and the volumes within the volume group, has data assurance protection to make sure that the data maintains its integrity. When you use this parameter, only protected drives can be used for the volume group. These settings are valid:</p> <ul style="list-style-type: none"> ▪ none – The volume group does not have data assurance protection. ▪ enabled – The volume group has data assurance protection. The volume group supports protected information and is formatted with protection information enabled. |
| dataAssurance | <p>The setting to specify that a volume group, and the volumes within the volume group, has data assurance protection to make sure that the data maintains its integrity. When you use this parameter, only protected drives can be used for the volume group. These settings are valid:</p> <ul style="list-style-type: none"> ▪ none – The volume group does not have data assurance protection. ▪ enabled – The volume group has data assurance protection. The volume group supports protected information and is formatted with protection information enabled. |

Notes

The `drives` parameter supports both high-capacity drive trays and low-capacity drive trays. A high-capacity drive tray has drawers that hold the drives. The drawers slide out of the drive tray to provide access to the drives. A low-capacity drive tray does not have drawers. For a high-capacity drive tray, you must specify the identifier (ID) of the drive tray, the ID of the drawer, and the ID of the slot in which a drive resides. For a low-capacity drive tray, you need only specify the ID of the drive tray and the ID of the slot in which a drive resides. For a low-capacity drive tray, an alternative method for identifying a location for a drive is to specify the ID of the drive tray, set the ID of the drawer to 0, and specify the ID of the slot in which a drive resides.

If you set the `raidLevel` parameter to RAID 1, the controller firmware takes the list of drives and pairs them by using this algorithm:

Data = X
drive

Parity = N/2 +
drive X

In this algorithm X is 1 to N/2, and N is the number of drives in the list. For example, if you have six drives, the mirrored pairs are as follows:

| Data | Parity |
|------|---------------|
| 1 | $N/2 + 1 = 4$ |
| 2 | $N/2 + 2 = 5$ |
| 3 | $N/2 + 3 = 6$ |

You can use any combination of alphanumeric characters, underscore (_), hyphen (-), and pound (#) for the names. Names can have a maximum of 30 characters.

The `owner` parameter defines which controller owns the volume. The preferred controller ownership of a volume is the controller that currently owns the volume group.

If you do not specify a capacity using the `capacity` parameter, all of the drive capacity that is available in the volume group is used. If you do not specify capacity units, `bytes` is used as the default value.

Segment Size

The size of a segment determines how many data blocks that the controller writes on a single drive in a volume before writing data on the next drive. Each data block stores 512 bytes of data. A data block is the smallest unit of storage. The size of a segment determines how many data blocks that it contains. For example, an 8-KB segment holds 16 data blocks. A 64-KB segment holds 128 data blocks.

When you enter a value for the segment size, the value is checked against the supported values that are provided by the controller at run time. If the value that you entered is not valid, the controller returns a list of valid values. Using a single drive for a single request leaves other drives available to simultaneously service other requests.

If the volume is in an environment where a single user is transferring large units of data (such as multimedia), performance is maximized when a single data transfer request is serviced with a single data stripe. A data stripe is the segment size that is multiplied by the number of drives in the volume group that are used for data transfers. In this case, multiple drives are used for the same request, but each drive is accessed only once.

For optimal performance in a multiuser database or file system storage environment, set your segment size to minimize the number of drives that are required to satisfy a data transfer request.

Cache Read Prefetch

Cache read prefetch lets the controller copy additional data blocks into cache while the controller reads and copies data blocks that are requested by the host from the drive into cache. This action increases the chance that a future request for data can be fulfilled from cache. Cache read prefetch is important for multimedia applications that use sequential data transfers. The configuration settings for the storage array that you use determine the number of additional data blocks that the controller reads into cache. Valid values for the `cacheReadPrefetch` parameter are **TRUE** or **FALSE**.

You do not need to enter a value for the `cacheReadPrefetch` parameter or the `segmentSize` parameter. If you do not enter a value, the controller firmware uses the `usageHint` parameter with `fileSystem` as the default value. Entering a value for the `usageHint` parameter and a value for the `cacheReadPrefetch` parameter or a value for the `segmentSize` parameter does not cause an error. The value that you enter for the `cacheReadPrefetch` parameter or the `segmentSize` parameter takes priority over the value for the `usageHint` parameter.

Tray Loss Protection and Drawer Loss Protection

For tray loss protection to work, each drive in a volume group must be on a separate tray. If you set the `trayLossProtect` parameter to **TRUE** and have selected more than one drive from any one tray, the storage array returns an error. If you set the `trayLossProtect` parameter to **FALSE**, the storage array performs operations, but the volume group that you create might not have tray loss protection.

Tray loss protection is not valid when you create volumes on existing volume groups.

The `drawerLossProtect` parameter defines if data on a volume is accessible if a drawer fails. When you assign the drives, if you set the `drawerLossProtect` parameter to **TRUE** and select more than one drive from any one drawer, the storage array returns an error. If you set the `drawerLossProtect` parameter to **FALSE**, the storage array performs operations, but the volume group that you create might not have drawer loss protection.

You must set the `trayLossProtect` parameter and the `drawerLossProtect` parameter to the same value. Both of the parameters must be either **TRUE** or **FALSE**. If the `trayLossProtect` parameter and the `drawerLossProtect` parameter are set to different values, the storage array returns an error.

Security Type

The `securityType` parameter is valid for drives that are capable of full disk encryption (FDE). With FDE, the controller firmware can create a key and activate the drive security feature. The drive security feature encrypts data as the data is written to the drive and decrypts the data as the data is read from the drive. Without the key created by the controller, the data written to the drive is inaccessible.

Before you can set the `securityType` parameter to **capable** or **enabled**, you must create a storage array security key. Use the `create storageArray securityKey` command to create a storage array security key. These commands are related to the security key:

- `create storageArray securityKey`
- `enable volumeGroup [volumeGroupName] security`
- `export storageArray securityKey`
- `import storageArray securityKey`
- `set storageArray securityKey`
- `start secureErase (drive | drives)`

Minimum Firmware Level

5.20

7.10 adds RAID Level 6 capability and the `dssPreAllocate` parameter.

7.60 adds the `drawerID` user input and the `drawerLossProtect` parameter.

7.75 adds the `dataAssurance` parameter.

Create Remote Mirror

This command creates both the primary volume and the secondary volume for a remote mirrored pair. This command also sets the write mode (synchronous write mode or asynchronous write mode) and the synchronization priority.

Syntax

```
create remoteMirror primary="primaryVolumeName"
secondary="secondaryVolumeName"
(remoteStorageArrayName="storageArrayName" |
remoteStorageArrayWwn="wwID")
[remotePassword="password"
syncPriority=(highest | high | medium | low | lowest)
autoResync=(enabled | disabled)
writeOrder=(preserved | notPreserved)
writeMode=(synchronous | asynchronous)]
```

Parameters

| Parameter | Description |
|------------------------|---|
| primary | The name of an existing volume on the local storage array that you want to use for the primary volume. Enclose the primary volume name in double quotation marks (" "). |
| secondary | The name of an existing volume on the remote storage array that you want to use for the secondary volume. Enclose the secondary volume name in double quotation marks (" "). |
| remoteStorageArrayName | The name of the remote storage array. Enclose the remote storage array name in double quotation marks (" "). |
| remoteStorageArrayWwn | The World Wide Identifier (WWID) of the remote storage array. Enclose the WWID in double quotation marks (" "). |
| remotePassword | The password for the remote storage array. Use this parameter when the remote storage array is password protected. Enclose the password in double quotation marks (" "). |
| syncPriority | The priority that full synchronization has relative to host I/O activity. Valid values are highest , high , medium , low , or lowest . |
| autoResync | The settings for automatic resynchronization between the primary volumes and the secondary volumes of a remote-mirror pair. This parameter has these values: <ul style="list-style-type: none"> enabled– Automatic resynchronization is turned on. You do not need to do anything further to resynchronize the primary volume and the secondary volume. |

| Parameter | Description |
|-------------------------|--|
| | <ul style="list-style-type: none"> ▪ disabled– Automatic resynchronization is turned off. To resynchronize the primary volume and the secondary volume, you must run the resume remoteMirror command. |
| <code>writeOrder</code> | The write order for data transmission between the primary volume and the secondary volume. Valid values are preserved or notPreserved . |
| <code>writeMode</code> | How the primary volume writes to the secondary volume. Valid values are synchronous or asynchronous . |

Notes

You can use any combination of alphanumeric characters, hyphens, and underscores for the names. Names can have a maximum of 30 characters.

When you choose the primary volume and the secondary volume, the secondary volume must be of equal or greater size than the primary volume. The RAID level of the secondary volume does not have to be the same as the primary volume.

Product shipments using the CE6998 or CE7900 controller define a maximum of 128 remote mirrors. The CDE3992 and CDE3994 controllers can define a maximum of 64 remote mirrors.

Passwords are stored on each storage array in a management domain. If a password was not previously set, you do not need a password. The password can be any combination of alphanumeric characters with a maximum of 30 characters. (You can define a storage array password by using the **set storageArray** command.)

Synchronization priority defines the amount of system resources that are used to synchronize the data between the primary volume and the secondary volume of a mirror relationship. If you select the highest priority level, the data synchronization uses the most system resources to perform the full synchronization, which decreases performance for host data transfers.

The `writeOrder` parameter applies only to asynchronous mirrors and makes them become part of a consistency group. Setting the `writeOrder` parameter to **preserved** causes the remote mirrored pair to transmit data from the primary volume to the secondary volume in the same order as the host writes to the primary volume. In the event of a transmission link failure, the data is buffered until a full synchronization can occur. This action can require additional system overhead to maintain the buffered data, which slows operations. Setting the `writeOrder` parameter to **notPreserved** frees the system from having to maintain data in a buffer, but it requires forcing a full synchronization to make sure that the secondary volume has the same data as the primary volume.

Minimum Firmware Level

6.10

Create Snapshot Volume

This command creates a snapshot volume of a base volume. You can also use this command to create a new repository volume group if one does not already exist, or if you would prefer a different repository volume group. This command defines three ways to create a snapshot volume:

- In a new repository volume group created from user-defined drives
- In a new repository volume group created from a user-defined number of drives
- In an existing repository volume group

If you choose to define a number of drives, the controller firmware chooses which drives to use for the snapshot volume.

Syntax (User-Defined Drives)

```
create snapshotVolume baseVolume="baseVolumeName"
(repositoryRAIDLevel=(1 | 3 | 5 | 6)
repositoryDrives=(trayID1,drawerID1,slotID1 ... trayIDn,drawerIDn,slotIDn)
[repositoryVolumeGroupUserLabel="repositoryVolumeGroupName"
trayLossProtect=(TRUE | FALSE)
drawerLossProtect=(TRUE | FALSE)
freeCapacityArea=freeCapacityIndexNumber
userLabel="snapshotVolumeName"
warningThresholdPercent=percentValue
repositoryPercentOfBase=percentValue
repositoryUserLabel="repositoryName"
repositoryFullPolicy=(failBaseWrites | failSnapshot) |
enableSchedule=(TRUE | FALSE) |
schedule=(immediate | snapshotSchedule)]
```

Syntax (User-Defined Number of Drives)

```
create snapshotVolume baseVolume="baseVolumeName"
repositoryRAIDLevel=(1 | 3 | 5 | 6)
repositoryDriveCount=numberOfDrives
[repositoryVolumeGroupUserLabel="repositoryVolumeGroupName"
driveMediaType=(HDD | SSD | unknown | allMedia)]
driveType=(fibre | SATA | SAS)
trayLossProtect=(TRUE | FALSE)
drawerLossProtect=(TRUE | FALSE)
userLabel="snapshotVolumeName"
warningThresholdPercent=percentValue
repositoryPercentOfBase=percentValue
repositoryUserLabel="repositoryName"
repositoryFullPolicy=(failBaseWrites | failSnapshot) |
enableSchedule=(TRUE | FALSE) |
schedule=(immediate | snapshotSchedule)]
```

Syntax (Existing Repository Volume Group)

```
create snapshotVolume baseVolume="baseVolumeName"
[repositoryVolumeGroup="repositoryVolumeGroupName"
repositoryUserLabel="repositoryName"
freeCapacityArea=freeCapacityIndexNumber
userLabel="snapshotVolumeName"
warningThresholdPercent=percentValue
repositoryPercentOfBase=percentValue
repositoryFullPolicy=(failBaseWrites | failSnapshot) |
enableSchedule=(TRUE | FALSE) |
schedule=(immediate | snapshotSchedule)]
```

Parameters

| Parameter | Description |
|--------------------------------|--|
| baseVolume | The name of the base volume from which you want to take a snapshot. Enclose the base volume name in double quotation marks (" "). |
| repositoryRAIDLevel | Use this parameter when you create a new volume group. The RAID level for the snapshot repository volume group. Valid values are 1, 3, 5, or 6. |
| repositoryDrives | Use this parameter when you create a new volume group. The drives that you want to assign to the snapshot repository volume group. For high-capacity drive trays, specify the tray ID value, the drawer ID value, and the slot ID value for each drive that you assign to the snapshot repository volume. For low-capacity drive trays, specify the tray ID value and the slot ID value for each drive that you assign to the snapshot repository volume. Tray ID values are 0 to 99. Drawer ID values are 1 to 5. Slot ID values are 1 to 32. Enclose the tray ID values, the drawer ID values, and the slot ID values in parentheses. |
| repositoryDriveCount | Use this parameter when you create a new volume group. The number of unassigned drives that you want to use for the snapshot repository volume group. |
| repositoryVolumeGroupUserLabel | Use this parameter when you create a new volume group. The name of a new volume group to be used for the repository volume. Enclose the repository volume group name in double quotation marks (" "). |
| repositoryVolumeGroup | The name of an existing volume group where you want to place the repository volume. Use this parameter if you do not want to put the repository volume in the same volume group as the base volume. The default is to use the same volume group for both the base volume and the repository volume. Enclose the name of the repository volume group in double quotation marks (" "). |
| userLabel | The name that you want to give to the snapshots volume. If you do not want to provide a name, the CLI creates a name using the base volume user label that you provide. |

| Parameter | Description |
|-------------------|--|
| trayLossProtect | The setting to enforce tray loss protection when you create the snapshot repository volume. To enforce tray loss protection, set this parameter to TRUE . The default value is FALSE . |
| drawerLossProtect | The setting to enforce drawer loss protection when you create the mirror repository volume. To enforce drawer loss protection, set this parameter to TRUE . The default value is FALSE . |
| driveMediaType | <p>The type of drive medium that you want to use for the mirror repository volume. Valid drive media are these:</p> <ul style="list-style-type: none"> ▪ HDD – Use this option when you have hard drives in the drive tray. ▪ SSD – Use this option when you have solid state drives in the drive tray. ▪ unknown – Use if you are not sure what types of drive media are in the drive tray. ▪ allMedia – Use this option when you want to use all types of drive media that are in the drive tray. <p>Use this parameter when you use the <code>repositoryDriveCount</code> parameter. You must use this parameter when you have more than one type of drive media in your storage array.</p> |
| driveType | <p>The type of drive that you want to use in the volume. You cannot mix drive types. You must use this parameter when you have more than one type of drive in your storage array. Valid drive types are :</p> <ul style="list-style-type: none"> ▪ fibres ▪ SATA ▪ SAS <p>If you do not specify a drive type, the command defaults to fibres. Use this parameter when you use the <code>repositoryDriveCount</code> parameter.</p> |
| freeCapacityArea | The index number of the free space in an existing volume group that you want to use to create the snapshot repository volume. Free capacity is defined as the free capacity between existing volumes in a volume group. For example, a volume group might have these areas: volume 1, |

| Parameter | Description |
|-------------------------|--|
| | <p>free capacity, volume 2, free capacity, volume 3, free capacity. To use the free capacity following volume 2, you would specify:</p> <pre>freeCapacityArea=2</pre> <p>Run the show volumeGroup command to determine if a free capacity area exists.</p> |
| warningThresholdPercent | <p>The percentage of repository capacity at which you receive a warning that the snapshot repository volume is nearing full. Use integer values. For example, a value of 70 means 70 percent. The default value is 50.</p> |
| repositoryPercentOfBase | <p>The size of the snapshot repository volume as a percentage of the base volume. Use integer values. For example, a value of 40 means 40 percent. The default value is 20.</p> |
| repositoryUserLabel | <p>The name that you want to give to the snapshot repository volume. Enclose the snapshot repository volume name in double quotation marks (" ").</p> |
| repositoryFullPolicy | <p>How you want snapshot processing to continue if the snapshot repository volume is full. You can choose to fail writes to the base volume (failBaseWrites) or fail the snapshot volume (failSnapshot). The default value is failSnapshot.</p> |
| enableSchedule | <p>Use this parameter to turn on or to turn off the ability to schedule a snapshot operation. To turn on snapshot scheduling, set this parameter to TRUE. To turn off snapshot scheduling, set this parameter to FALSE.</p> |
| schedule | <p>Use this parameter to schedule a snapshot operation.</p> <p>You can use one of these options for setting a schedule for a snapshot operation:</p> <ul style="list-style-type: none"> ▪ immediate ▪ startDate ▪ scheduleDay ▪ startTime ▪ scheduleInterval ▪ endDate ▪ noEndDate |

| Parameter | Description |
|-----------|--|
| | <ul style="list-style-type: none"> ▪ <code>timesPerDay</code> <p>See the "Notes" section for information explaining how to use these options.</p> |

Notes

The volume that you are taking a snapshot of must be a standard volume in the storage array. The maximum number of snapshot volumes that you can create is one-half of the total number of volumes that are supported by a controller.

You can use any combination of alphanumeric characters, underscore (`_`), hyphen (`-`), and pound (`#`) for the names. Names can have a maximum of 30 characters.

One technique for naming the snapshot volume and the snapshot repository volume is to add a hyphenated suffix to the original base volume name. The suffix distinguishes between the snapshot volume and the snapshot repository volume. For example, if you have a base volume with a name of Engineering Data, the snapshot volume can have a name of Engineering Data-S1, and the snapshot repository volume can have a name of EngineeringData-R1.

If you do not choose a name for either the snapshot volume or the snapshot repository volume, the storage management software creates a default name by using the base volume name. An example of the snapshot volume name that the controllers might create is, if the base volume name is `aaa` and does not have a snapshot volume, the default snapshot volume name is `aaa-1`. If the base volume already has $n-1$ number of snapshot volumes, the default name is `aaa-n`. An example of the snapshot repository volume name that the controller might create is, if the base volume name is `aaa` and does not have a snapshot repository volume, the default snapshot repository volume name is `aaa-R1`. If the base volume already has $n-1$ number of snapshot repository volumes, the default name is `aaa-Rn`.

If you do not specify the unconfigured space or free space, the snapshot repository volume is placed in the same volume group as the base volume. If the volume group where the base volume resides does not have enough space, this command fails.

The `repositoryDrives` parameter supports both high-capacity drive trays and low-capacity drive trays. A high-capacity drive tray has drawers that hold the drives. The drawers slide out of the drive tray to provide access to the drives. A low-capacity drive tray does not have drawers. For a high-capacity drive tray, you must specify the identifier (ID) of the drive tray, the ID of the drawer, and the ID of the slot in which a drive resides. For a low-capacity drive tray, you need only specify the ID of the drive tray and the ID of the slot in which a drive resides. For a low-capacity drive tray, an alternative method for identifying a location for a drive is to specify the ID of the drive tray, set the ID of the drawer to `0`, and specify the ID of the slot in which a drive resides.

Tray Loss Protection and Drawer Loss Protection

When you assign the drives, if you set the `trayLossProtect` parameter to **TRUE** and have selected more than one drive from any one tray, the storage array returns an error. If you set the `trayLossProtect` parameter to **FALSE**, the storage array performs operations, but the volume group that you create might not have tray loss protection.

When the controller firmware assigns the drives, if you set the `trayLossProtect` parameter to **TRUE**, the storage array returns an error if the controller firmware cannot provide drives that result in the new volume group having tray loss protection. If you set the `trayLossProtect` parameter to **FALSE**, the storage array performs the operation even if it means the volume group might not have tray loss protection.

The `drawerLossProtect` parameter defines if data on a volume is accessible if a drawer fails. When you assign the drives, if you set the `drawerLossProtect` parameter to **TRUE** and select more than one drive from any one drawer, the storage array returns an error. If you set the `drawerLossProtect` parameter to **FALSE**, the storage array performs operations, but the volume group that you create might not have drawer loss protection.

If you have a storage configuration that includes a drive tray that has drawers to hold the drives, follow these guidelines when configuring tray loss protection:

- If you set `trayLossProtect` to **TRUE**, then you must set `drawerLossProtect` to **TRUE**.
- If you set `trayLossProtect` to **FALSE**, then you can set `drawerLossProtect` to either **TRUE** or **FALSE**.

If you set `trayLossProtect` to **TRUE** and `drawerLossProtect` to **FALSE**, the storage array returns an error.

Scheduling Snapshots

The `enableSchedule` parameter and the `schedule` parameter provide a way for you to schedule automatic snapshots. Using these parameters, you can schedule snapshots daily, weekly, or monthly (by day or by date). The `enableSchedule` parameter turns on or turns off the ability to schedule snapshots. When you enable scheduling, you use the `schedule` parameter to define when you want the snapshots to occur.

This list explains how to use the options for the `schedule` parameter:

- **immediate** – As soon as you enter the command, a snapshot volume is created and a copy-on-write operation begins.
- **startDate** – A specific date on which you want to create a snapshot volume and perform a copy-on-write operation. The format for entering the date is **MM:DD:YY**. If you do not provide a start date, the current date is used. An example of this option is `startDate=06:27:11`.
- **scheduleDay** – A day of the week on which you want to create a snapshot volume and perform a copy-on-write operation. The values that you can enter are: **monday**, **tuesday**, **wednesday**, **thursday**, **friday**, **saturday**, **sunday**, and **all**. An example of this option is `scheduleDay=wednesday`.
- **startTime** – The time of a day that you want to create a snapshot volume and start performing a copy-on-write operation. The format for entering the time is **HH:MM**, where **HH** is the hour and **MM** is the minute past the hour. Use a 24-hour clock. For example, 2:00 in the afternoon is 14:00. An example of this option is `startTime=14:27`.
- **scheduleInterval** – An amount of time, in minutes, that you want to have as a minimum between copy-on-write operation. It is possible for you to create a schedule in which you have overlapping copy-on-write operations because of the duration a copy operation. You can make sure that you have time between copy-on-write operations by using this option. The maximum value for the `scheduleInterval` option is 1440 minutes. An example of this option is `scheduleInterval=180`.
- **endDate** – A specific date on which you want to stop creating a snapshot volume and end the copy-on-write operations. The format for entering the date is **MM:DD:YY**. An example of this option is `endDate=11:26:11`.
- **noEndDate** – Use this option if you do not want your scheduled copy-on-write operation to end. If you later decide to end the copy-on-write operations you must re-enter the **create snapshotVolume** command and specify an end date.
- **timesPerDay** – The number of times that you want the schedule to run in a day. An example of this option is `timesPerDay=4`.

If you also use the `scheduleInterval` option, the firmware will choose between the `timesPerDay` option and the `scheduleInterval` option by selecting the lowest value of the two options. The firmware calculates an integer value for the `scheduleInterval` option by dividing 1440 by a the `scheduleInterval` option value that you set. For example, $1440/180 = 8$. The firmware then compares the `timesPerDay` integer value with the calculated `scheduleInterval` integer value and uses the smaller value.

To remove a schedule, use the `delete snapshot` command with the `schedule` parameter. The `delete snapshot` command with the `schedule` parameter deletes only the schedule, not the snapshot volume.

Minimum Firmware Level

5.00

7.10 adds RAID 6 Level capability.

7.60 adds the `drawerID` user input, the `driveMediaType` parameter, and the `drawerLossProtect` parameter.

7.77 adds scheduling.

Create Storage Array Security Key

This command creates a new security key for a storage array that has full disk encryption (FDE) drives. This command also sets the security definitions and sets the state to Security Enabled.



NOTE Before you create a storage array security key, you must set the password for the storage array. Use the `set storageArray` command to set the password for the storage array.

Syntax

```
create storageArray securityKey
[keyIdentifier="keyIdentifierString"] |
passPhrase="passPhraseString" |
file="fileName" |
commitSecurityKey=(TRUE | FALSE)
```

Parameters

| Parameter | Description |
|----------------------------|---|
| <code>keyIdentifier</code> | A character string that you can read that is a wrapper around a security key. Enclose the key identifier in double quotation marks (" "). |
| <code>passPhrase</code> | A character string that encrypts the security key so that you can store the security key in an external file. Enclose the pass phrase in double quotation marks (" "). For information about the correct form for creating a valid pass phrase, refer to the Notes in this command description. |
| <code>file</code> | The file path and the file name to which you want to save the security key. For example: file="C:\Program Files\CLI\sup\seckey.slk" |

| Parameter | Description |
|--------------------------------|---|
| | IMPORTANT – You must add a file extension of <code>.slk</code> to the end of the file name. Enclose the file path and name in double quotation marks (" "). |
| <code>commitSecurityKey</code> | This parameter commits the security key identifier to the storage array for all FDE drives as well as the controllers. After the security key identifier is committed, a key is required to read data or write data. The data can only be read or changed by using a key, and the drive can never be used in a non-secure mode without rendering the data useless or totally erasing the drive. |

Notes

Use this command for local key management only.

To use this command successfully, you need to have enough FDE drives to create at least one volume group.

The controller firmware creates a lock that restricts access to the FDE drives. FDE drives have a state called Security Capable. When you create a security key, the state is set to Security Enabled, which restricts access to all FDE drives that exist within the storage array.

You can have a storage array configuration with more than one set of encrypted volume groups. Each volume group can have a unique security key. The character string generated by the `keyIdentifier` parameter is a string that you can read and that enables you to identify the security key that you need. You can create a `keyIdentifier` by using one of these methods:

- You can enter up to 189 alphanumeric characters for a key identifier. The key identifier cannot have these characters:
 - White spaces
 - Punctuation
 - Symbols
- If you do not enter the `keyIdentifier` parameter, the controller automatically generates the `keyIdentifier` parameter.

Additional characters are automatically generated and appended to the end of the string that you enter for the key identifier. If you do not enter any string for the `keyIdentifier` parameter, the key identifier consists of only the characters that are automatically generated.

Your pass phrase must meet these criteria:

- The pass phrase must be between eight and 32 characters long.
- The pass phrase must contain at least one uppercase letter.
- The pass phrase must contain at least one lowercase letter.
- The pass phrase must contain at least one number.
- The pass phrase must contain at least one non-alphanumeric character, for example, `<` `>` `@` `+`.

 **NOTE** If your pass phrase does not meet these criteria, you will receive an error message and will be asked to retry the command.

Minimum Firmware Level

7.40

Create Volume Copy

This command creates a volume copy and starts the volume copy operation.

 **ATTENTION** Starting a volume copy operation overwrites all existing data on the target volume, makes the target volume read-only to hosts, and fails all snapshot volumes associated with the target volume, if any exist. If you have used the target volume as a copy before, be sure you no longer need the data or have it backed up.

This command creates volume copies in two ways:

- Volume copy without snapshot
- Volume copy with snapshot

If you use volume copy without snapshot you cannot write to the source volume until the copy operation is complete. If you want to be able to write to the source volume before the copy operation is complete, use volume copy with snapshot. You can select volume copy with snapshot through the optional parameters in the command syntax.

After completion of the volume copy with snapshot operation, the snapshot is disabled.

 **NOTE** You can have a maximum of eight volume copies in progress at one time. If you try to create more than eight volume copies at one time, the controllers return a status of Pending until one of the volume copies that is in progress finishes and returns a status of Complete.

Syntax

```
create volumeCopy source="sourceName"
target="targetName"
[copyPriority=(highest | high | medium | low | lowest)
targetReadOnlyEnabled=(TRUE | FALSE)
copyType=(offline | online)
repositoryPercentOfBase=(20 |40 | 60 | 120 | default) |
repositoryGroupPreference=(sameAsSource | otherThanSource |
... default)]
```

Parameters

| Parameter | Description |
|-----------|---|
| source | The name of an existing volume that you want to use as the source volume. Enclose the source volume name in double quotation marks (" "). |

| Parameter | Description |
|---------------------------|--|
| target | The name of an existing volume that you want to use as the target volume. Enclose the target volume name in double quotation marks (" "). |
| copyPriority | The priority that volume copy has relative to host I/O activity. Valid values are highest , high , medium , low , or lowest . |
| targetReadOnlyEnabled | The setting so that you can write to the target volume or only read from the target volume. To write to the target volume, set this parameter to FALSE . To prevent writing to the target volume, set this parameter to TRUE . |
| copyType | Use this parameter to create a volume copy with a snapshot. Creating a volume copy with a snapshot enables you to continue to write to the source volume while creating the volume copy. To create a volume copy with a snapshot, set this parameter to online . To create a volume copy without a snapshot, set this parameter to offline . If you do not use this parameter, the volume copy is created without a snapshot. |
| repositoryPercentOfBase | This parameter determines the size of the repository volume for the snapshot when you are creating a volume copy with a snapshot. The size of the repository volume is expressed as a percentage of the source volume, which is also called the base volume. Valid values for this parameter are 20 , 40 , 60 , 120 , and default . The default value is 20. If you do not use this parameter, the firmware uses a value of 20 percent. You must use the <code>copyType</code> parameter with the <code>repositoryPercentOfBase</code> parameter. |
| repositoryGroupPreference | This parameter determines to which volume group the snapshot repository volume is written. You have these choices: <ul style="list-style-type: none"> ▪ sameAsSource – The snapshot repository volume is written to the same volume group as the source volume if space is available. ▪ otherThanSource – The snapshot repository volume is written to a different volume group. Firmware determines which volume group based on available space on the volume groups. ▪ default – The snapshot repository volume is written to any volume group that has space. |

| Parameter | Description |
|-----------|---|
| | <p>For best performance, use the sameAsSource option.</p> <p>You must use the <code>copyType</code> parameter with the <code>repositoryGroupPreference</code> parameter.</p> |

Notes

You can use any combination of alphanumeric characters, happens, and underscores for the names. Names can have a maximum of 30 characters.

Copy priority defines the amount of system resources that are used to copy the data between the source volume and the target volume of a volume copy pair. If you select the highest priority level, the volume copy uses the most system resources to perform volume copy, which decreases performance for host data transfers.

Minimum Firmware Level

5.40

7.77 adds creating a volume copy with snapshot.

Create Volume Group

This command creates either a free-capacity volume group or a volume group with one volume when you enter a set of unassigned drives.

Syntax

```
create volumeGroup
drives=(trayID1,drawerID1,slotID1 ... trayIDn,drawerIDn,slotIDn)
raidLevel=(0 | 1 | 3 | 5 | 6)
userLabel="volumeGroupName"
[driveMediaType=(HDD | SSD | unknown | allMedia)
driveType=(fibre | SATA | SAS)
trayLossProtect=(TRUE | FALSE)
drawerLossProtect=(TRUE | FALSE)
securityType=(none | capable | enabled)
dataAssurance=(none | enabled)]
```

```
create volumeGroup
drives=(trayID1,drawerID1,slotID1 ... trayIDn,drawerIDn,slotIDn)
raidLevel=(0 | 1 | 3 | 5 | 6)
userLabel="volumeGroupName"
[driveMediaType=(HDD | SSD | unknown | allMedia)
driveType=(fibre | SATA | SAS)
trayLossProtect=(TRUE | FALSE)
drawerLossProtect=(TRUE | FALSE)
securityType=(none | capable | enabled)
dataAssurance=(none | enabled)]
```

Parameters

| Parameter | Description |
|-----------------|---|
| drives | The drives that you want to assign to the volume group that you want to create. For high-capacity drive trays, specify the tray ID value, the drawer ID value, and the slot ID value for each drive that you assign to the volume group. For low-capacity drive trays, specify the tray ID value and the slot ID value for each drive that you assign to the volume group. Tray ID values are 0 to 99. Drawer ID values are 1 to 5. Slot ID values are 1 to 32. Enclose the tray ID values, the drawer ID values, and the slot ID values in parentheses. |
| raidLevel | The RAID level of the volume group that contains the volume. Valid values are 0, 1, 3, 5, or 6. |
| userLabel | The alphanumeric identifier (including - and _) that you want to give the new volume group. Enclose the volume group identifier in double quotation marks (" "). |
| driveMediaType | The type of drive media that you want to use for the volume group You must use this parameter when you have more than one type of drive media in your storage array. Valid drive media are: <ul style="list-style-type: none"> ▪ HDD – Use this option when you have hard drives in the drive tray. ▪ SSD – Use this option when you have solid state drives in the drive tray. ▪ unknown – Use if you are not sure what types of drive media are in the drive tray. ▪ allMedia – Use this option when you want to use all types of drive media that are in the drive tray. |
| driveType | The type of drive that you want to use in the volume. You cannot mix drive types. You must use this parameter when you have more than one type of drive in your storage array. Valid drive types are : <ul style="list-style-type: none"> ▪ fibred ▪ SATA ▪ SAS If you do not specify a drive type, the command defaults to fibred . |
| trayLossProtect | The setting to enforce tray loss protection when you create the volume group. To enforce tray loss protection, set this parameter to TRUE . The default value is FALSE . |

| Parameter | Description |
|-------------------|---|
| drawerLossProtect | The setting to enforce drawer loss protection when you create the volume group. To enforce drawer loss protection, set this parameter to TRUE . The default value is FALSE . |
| securityType | The setting to specify the security level when creating the volume groups and all associated volumes. These settings are valid: <ul style="list-style-type: none"> ▪ none – The volume group and volumes are not secure. ▪ capable – The volume group and volumes are capable of having security set, but security has not been enabled. ▪ enabled – The volume group and volumes have security enabled. |
| dataAssurance | The setting to specify that a volume group, and the volumes within the volume group, has data assurance protection to make sure that the data maintains its integrity. When you use this parameter, only protected drives can be used for the volume group. These settings are valid: <ul style="list-style-type: none"> ▪ none – The volume group does not have data assurance protection. ▪ enabled – The volume group has data assurance protection. The volume group supports protected information and is formatted with protection information enabled. |
| dataAssurance | The setting to specify that a volume group, and the volumes within the volume group, has data assurance protection to make sure that the data maintains its integrity. When you use this parameter, only protected drives can be used for the volume group. These settings are valid: <ul style="list-style-type: none"> ▪ none – The volume group does not have data assurance protection. ▪ enabled – The volume group has data assurance protection. The volume group supports protected information and is formatted with protection information enabled. |

Notes

The `drives` parameter supports both high-capacity drive trays and low-capacity drive trays. A high-capacity drive tray has drawers that hold the drives. The drawers slide out of the drive tray to provide access to the drives. A low-capacity drive tray does not have drawers. For a high-capacity drive tray, you must specify the identifier (ID) of the drive tray, the ID of the drawer, and the ID of the slot in which a drive resides. For a

low-capacity drive tray, you need only specify the ID of the drive tray and the ID of the slot in which a drive resides. For a low-capacity drive tray, an alternative method for identifying a location for a drive is to specify the ID of the drive tray, set the ID of the drawer to 0, and specify the ID of the slot in which a drive resides.

If you do not specify a capacity by using the `capacity` parameter, all of the drive capacity that is available in the volume group is used. If you do not specify capacity units, `bytes` is used as the default value.

Cache Read Prefetch

The `cacheReadPrefetch` command lets the controller copy additional data blocks into cache while the controller reads and copies data blocks that are requested by the host from the drives into cache. This action increases the chance that a future request for data can be fulfilled from cache. Cache read prefetch is important for multimedia applications that use sequential data transfers. The configuration settings for the storage array that you use determine the number of additional data blocks that the controller reads into cache. Valid values for the `cacheReadPrefetch` parameter are **TRUE** or **FALSE**.

You do not need to enter a value for the `cacheReadPrefetch` parameter or the `segmentSize` parameter. If you do not enter a value, the controller firmware uses the `usageHint` parameter with **fileSystem** as the default value. Entering a value for the `usageHint` parameter and a value for the `cacheReadPrefetch` parameter or a value for the `segmentSize` parameter does not cause an error. The value that you enter for the `cacheReadPrefetch` parameter or the `segmentSize` parameter takes priority over the value for the `usageHint` parameter.

Segment Size

The size of a segment determines how many data blocks that the controller writes on a single drive in a volume before writing data on the next drive. Each data block stores 512 bytes of data. A data block is the smallest unit of storage. The size of a segment determines how many data blocks that it contains. For example, an 8-KB segment holds 16 data blocks. A 64-KB segment holds 128 data blocks.

When you enter a value for the segment size, the value is checked against the supported values that are provided by the controller at run time. If the value that you entered is not valid, the controller returns a list of valid values. Using a single drive for a single request leaves other drives available to simultaneously service other requests.

If the volume is in an environment where a single user is transferring large units of data (such as multimedia), performance is maximized when a single data transfer request is serviced with a single data stripe. A data stripe is the segment size that is multiplied by the number of drives in the volume group that are used for data transfers. In this case, multiple drives are used for the same request, but each drive is accessed only once.

For optimal performance in a multiuser database or file system storage environment, set your segment size to minimize the number of drives that are required to satisfy a data transfer request.

Security Type

The `securityType` parameter is valid for drives that are capable of full disk encryption (FDE). With FDE, the controller firmware can create a key and activate the drive security feature. The drive security feature encrypts data as the data is written to the drive and decrypts the data as the data is read from the drive. Without the key created by the controller, the data written to the drive is inaccessible.

Before you can set the `securityType` parameter to **capable** or **enabled**, you must create a storage array security key. Use the `create storageArray securityKey` command to create a storage array security key. These commands are related to the security key:

- `create storageArray securityKey`

- `enable volumeGroup [volumeGroupName] security`
- `export storageArray securityKey`
- `import storageArray securityKey`
- `set storageArray securityKey`
- `start secureErase (drive | drives)`

Tray Loss Protection and Drawer Loss Protection

For tray loss protection to work, each drive in a volume group must be on a separate tray. If you set the `trayLossProtect` parameter to **TRUE** and have selected more than one drive from any one tray, the storage array returns an error. If you set the `trayLossProtect` parameter to **FALSE**, the storage array performs operations, but the volume group that you create might not have tray loss protection.

Tray loss protection is not valid when you create volumes on existing volume groups.

The `drawerLossProtect` parameter defines if data on a volume is accessible if a drawer fails. When you assign the drives, if you set the `drawerLossProtect` parameter to **TRUE** and select more than one drive from any one drawer, the storage array returns an error. If you set the `drawerLossProtect` parameter to **FALSE**, the storage array performs operations, but the volume group that you create might not have drawer loss protection.

You must set the `trayLossProtect` parameter and the `drawerLossProtect` parameter to the same value. Both of the parameters must be either **TRUE** or **FALSE**. If the `trayLossProtect` parameter and the `drawerLossProtect` parameter are set to different values, the storage array returns an error.

Minimum Firmware Level

7.10

7.50 adds the `securityType` parameter.

7.60 adds the `drawerID` user input, the `driveMediaType` parameter, and the `drawerLossProtect` parameter.

7.75 adds the `dataAssurance` parameter.

Deactivate Remote Mirror

This command deactivates the Remote Volume Mirroring premium feature, disassembles the mirror repository volume, and releases the controller owner of the secondary volume. The controller host port that is dedicated to the secondary volume is available for host data transfers.

Syntax

```
deactivate storageArray feature=remoteMirror
```

Parameters

None.

Minimum Firmware Level

6.10

Delete Host

This command deletes one or more hosts.

Syntax

```
delete (host [hostName] |
hosts ["hostName1" ... "hostNameN"])
```

Parameters

| Parameter | Description |
|-----------|--|
| host | The name of the host that you want to delete. Enclose the host name in square brackets ([]). If the host name has special characters, you also must enclose the host name in double quotation marks (" "). |
| hosts | The names of several hosts that you want to delete. Enter the names of the hosts using these rules: <ul style="list-style-type: none"> ▪ Enclose all of the names in square brackets ([]). ▪ Enclose each of the names in double quotation marks (" "). ▪ Separate each of the names with a space. |

Notes

A host is a computer that is attached to the storage array and accesses the volumes on the storage array through the host ports on the host.

Minimum Firmware Level

5.20

Delete Host Group

This command deletes a host group.



ATTENTION Possible damage to the storage array configuration – This command deletes all of the host definitions in the host group.

Syntax

```
delete hostGroup [hostGroupName]
```

Parameter

| Parameter | Description |
|-----------|---|
| hostGroup | The name of the host group that you want to delete. Enclose the host group name in square brackets ([]). If the host group name has special characters, you also must enclose the host group name in double quotation marks (" "). |

Notes

A host group is an optional topological element that is a collection of hosts that share access to the same volumes. The host group is a logical entity.

Minimum Firmware Level

5.20

Delete Host Port

This command deletes a host port identification. The identification is a software value that represents the physical host port to the controller. By deleting the identification, the controller no longer recognizes instructions and data from the host port.

Syntax

```
delete hostPort [hostPortName]
```

Parameter

| Parameter | Description |
|-----------|--|
| hostPort | The name of the host port that you want to delete. Enclose the name of the host port in square brackets ([]). |

Notes

A host port is a physical connection on a host adapter that resides within a host computer. A host port provides a host access to the volumes in a storage array.

Minimum Firmware Level

5.20

Delete iSCSI Initiator

This command deletes a specific iSCSI initiator object.

Syntax

```
delete iscsiInitiator (["iscsiID"] | ["name"])
```

Parameters

| Parameter | Description |
|-----------------------------|---|
| <code>iscsiInitiator</code> | The identifier of the iSCSI initiator that you want to delete. The identifier of the iSCSI initiator can be either an iSCSI ID or a unique name. Enclose the identifier in double quotation marks (" "). You must also enclose the iscsiID in either square brackets ([]) or angle brackets (< >). |

Minimum Firmware Level

7.10

Delete Snapshot Volume

This command deletes one or more snapshot volumes or snapshot repository volumes. You can also use this command to remove schedules for creating snapshots.



ATTENTION Possible damage to the storage array configuration – All of the data in the volume is lost as soon as you run this command.

Syntax

```
delete snapshot (volume [volumeName] |
volumes [volumeName1 ... volumeNameN])
[schedule]
```

Parameters

| Parameter | Description |
|---|---|
| <code>volume</code> or <code>volumes</code> | The name of the snapshot volume that you want to delete. You can enter more than one snapshot volume name. Enclose the snapshot volume name in square brackets ([]). If the snapshot volume name has special characters, you also must enclose the snapshot volume name in double quotation marks (" "). |
| <code>schedule</code> | This parameter deletes the schedule for a specific snapshot volume. Only the schedule is deleted, the snapshot volume remains. |

Minimum Firmware Level

7.77

Delete Volume

This command deletes one or more standard volumes, snapshot volumes, or snapshot repository volumes.

 **ATTENTION Possible damage to the storage array configuration** – All of the data in the volume is lost as soon as you run this command.

Syntax

```
delete (allVolumes |
volume [volumeName] |
volumes [volumeName1 ... volumeNameN])
removeVolumeGroup=(TRUE | FALSE)
```

Parameters

| Parameter | Description |
|-------------------|---|
| allVolumes | This parameter deletes all of the volumes in a storage array. |
| volume or volumes | The name of the volume that you want to delete. You can enter more than one volume name. Enclose the volume name in square brackets ([]). If the volume name has special characters, you also must enclose the volume name in double quotation marks (" "). |
| removeVolumeGroup | Deleting the last volume in a volume group does not delete the volume group. You can have a standalone volume group (minus any volumes). To remove the standalone volume group, set this parameter to TRUE . To keep standalone volume groups intact, set this parameter to FALSE . |

Notes

When you use the `allVolumes` parameter, this command deletes volumes until all of the volumes are removed or until an error is encountered. If an error is encountered, this command does not try to delete the remaining volumes. Deleting volumes from different volume groups is possible. All of the volume groups that become empty are deleted if you set the `removeVolumeGroup` parameter to **TRUE**.

If you want to delete an entire volume group, you can also use the `delete volumeGroup` command.

Minimum Firmware Level

6.10

7.10 adds the `removeVolumeGroup` parameter.

Delete Volume Group

 **ATTENTION Possible damage to the storage array configuration** – All of the data in the volume group is lost as soon as you run this command.

This command deletes an entire volume group and its associated volumes.

Syntax

```
delete volumeGroup [volumeGroupName]
```

Parameter

| Parameter | Description |
|-------------|--|
| volumeGroup | The alphanumeric identifier (including - and _) of the volume group that you want to delete. Enclose the volume group identifier in square brackets ([]). |

Minimum Firmware Level

6.10

Diagnose Controller

This command runs diagnostic tests on the controller. The diagnostic tests consist of loopback tests in which data is written to the drives and read from the drives.

Syntax

```
diagnose controller [(a | b)]
loopbackDriveChannel=(allchannels | (1 | 2 | 3 | 4 | 5 | 6 | 7 | 8))
testID=(1 | 2 | 3 | discreteLines)
[patternFile="filename"]
```

Parameters

| Parameter | Description |
|----------------------|---|
| controller | The controller on which you want to run the diagnostic tests. Valid controller identifiers are a or b , where a is the controller in slot A, and b is the controller in slot B. Enclose the controller identifier in square brackets ([]). If you do not specify a controller, the storage management software returns a syntax error. |
| loopbackDriveChannel | The drive channels on which you want to run the diagnostic tests. You can either choose to run the diagnostics on all channels or select a specific channel on which to run diagnostics. If you select a specific channel, valid values for the drive channels are 1 , 2 , 3 , 4 , 5 , 6 , 7 , or 8 . |
| testID | The identifier for the diagnostic test you want to run. The identifier and corresponding tests are as follows: <ul style="list-style-type: none"> ▪ 1 – Read test ▪ 2 – Write test ▪ 3 – Data loop-back test ▪ discreteLines – Discrete lines diagnostic test |

| Parameter | Description |
|-------------|--|
| patternFile | The file path and the file name that contains a data pattern that you want to use as test data. Enclose the file name of the data pattern in double quotation marks (" "). For example: file="C:\Program Files\CLI\sup\patfile.txt" |

Notes

When you run a data loop-back test, you can optionally specify a file that contains a data pattern. If you do not specify a file, the controller firmware provides a default pattern.

Discrete lines are control lines and status lines that are connected between two controllers in a controller tray. The discrete lines diagnostic test lets each controller check that control signal transitions can be observed at the control inputs of the alternate controller. The discrete lines diagnostic test automatically runs after each power-cycle or each controller-reset. You can run the discrete lines diagnostic test after you have replaced a component that failed the initial discrete lines diagnostic test. This test applies only to the CE6998 controller tray and the CE7900 controller tray. The discrete lines diagnostic test returns one of these messages:

- When the discrete lines diagnostic test runs successfully, this message appears:

```
The controller discrete lines successfully passed the diagnostic
test. No failures were detected.
```

- If the discrete lines diagnostic test fails, this message appears:

```
One or more controller discrete lines failed the diagnostic test.
```

- If the CLI cannot run the discrete lines diagnostic test, the CLI returns Error 270, which means that the discrete lines diagnostic test could not start nor complete.

Minimum Firmware Level

6.10 adds the read test, the write test, and the data loop-back test.

6.14 adds the discrete lines diagnostic test.

7.30 adds the updated drive channel identifier.

Diagnose Controller iSCSI Host Cable

This command runs diagnostic tests on the copper cables between iSCSI Host interface cards and a controller. You can run diagnostics on a selected port or all ports. The ports must be able to support the cable diagnostics. If the ports do not support cable diagnostics an error is returned.

Syntax

```
diagnose controller [(a | b)]
iscsiHostPorts=(all | ("wwID" | "gID"))
testID=cableDiagnostics
```

Parameters

| Parameter | Description |
|-----------------------------|--|
| <code>controller</code> | The controller on which you want to run the cable diagnostic test. Valid controller identifiers are a or b , where a is the controller in slot A, and b is the controller in slot B. Enclose the controller identifier in square brackets ([]). If you do not specify a controller, the storage management software returns a syntax error. |
| <code>iscsiHostPorts</code> | The 8-byte World Wide Identifier (WWID) or the 16-byte group identifier (GID) of the HBA or HCA host port. Enclose the WWID or the GID in double quotation marks (" "). |
| <code>testID</code> | The identifier for the diagnostic test that you want to run. For this diagnostic test, the only choice is cableDiagnostics . |

Notes

When you run the cable diagnostic test, the firmware returns the following information:

- Host Port: The port on which the diagnostic test was run.
- HIC: The host interface card associated with this port.
- The date and time the test was run.
- Status:
 - OK: All of the pairs of cables are good and do not have any faults.
 - Open: One or more of the four pairs of cables are open.
 - Short: One or more of the four pairs of cables are shorted.
 - Incomplete: One or more of the four pairs returned incomplete or invalid test results.
- Length – The Length of the cables are listed in meters and the following information about the cables is returned:
 - When the cable status is OK, the approximate lengths of the cable pairs are returned. The lengths of the cable paris are shown as a range (L1-L2), which are the shortest and the longest lengths of the cable pairs.
 - If the cable status is Open or Short, the approximate distance to the failure in the cable pairs. If there is one failure, the length is reported for that cable pair. If there is more than one failure, the information returned is both the shortest and longest lengths to the failures. The lengths are listed as a range (L1-L2) where L1<L2.
 - If the cable status is Incomplete, the information returned are the lengths for the shortest and longest cable pairs that the firmware can successfully test. The lengths are listed for the valid cable pairs as a range (L1-L2) where L1<L2.
- Register values for the cable diagnostic registers. The values are in a hexadecimal format:
 - Two bytes show the combined cable status (four bits per port).
 - Four two-byte numbers show the length of each channel.

Minimum Firmware Level

7.77

Diagnose Remote Mirror

This command tests the connection between the specified primary volumes and the mirror volumes on a storage array with the Remote Volume Mirroring premium feature enabled.

Syntax

```
diagnose remoteMirror (primary [primaryVolumeName] |
primaries [primaryVolumeName1 ... primaryVolumeNameN])
testID=connectivity
```

Parameter

| Parameter | Description |
|----------------------|---|
| primary or primaries | The name of the primary volume of the remote mirror pair that you want to test. You can enter more than one primary volume name. Enclose the primary volume names in square brackets ([]). If the primary volume name has special characters, you also must enclose the primary volume name in double quotation marks (" "). |

Minimum Firmware Level

6.10

Disable External Security Key Management

This command disables external security key management for a storage array that has full disk encryption drives.

Syntax

```
disable storageArray externalKeyManagement
file="fileName"
passPhrase="passPhraseString"
```

Parameters

| Parameter | Description |
|------------|---|
| file | The file path and the file name that has the security key. For example: file="C:\Program Files\CLI\sup\seckey.slk" IMPORTANT – The file name must have an extension of .slk. |
| passPhrase | A character string that encrypts the security key so that you can store the security key in an external file. |

Notes

Your pass phrase must meet these criteria:

- The pass phrase must be between eight and 32 characters long.
- The pass phrase must contain at least one uppercase letter.
- The pass phrase must contain at least one lowercase letter.
- The pass phrase must contain at least one number.
- The pass phrase must contain at least one non-alphanumeric character, for example, < > @ +.



NOTE If your pass phrase does not meet these criteria, you will receive an error message.

Minimum Firmware Level

7.70

Disable Storage Array Feature

This command disables a storage array premium feature. Run the **show storageArray** command to show a list of the feature identifiers for all enabled premium features in the storage array.

Syntax

```
disable storageArray [featurePack |
feature=(storagePartition2 | storagePartition4 |
storagePartition8 | storagePartition16 | storagePartition32 |
storagePartition64 | storagePartition96 | storagePartition128 |
storagePartition256 | storagePartitionMax |
snapshot2 | snapshot4 | snapshot8 | snapshot16 |
remoteMirror8 | remoteMirror16 | remoteMirror32 |
remoteMirror64 | remoteMirror128 | volumeCopy | goldKey |
mixedDriveTypes | highPerformanceTier | SSDSupport |
safeStoreSecurity | safeStoreExternalKeyMgr)]
```

Parameters

None.

Notes

If you specify the `remoteMirror` parameter, this command disables the Remote Volume Mirroring premium feature and takes away the structure of the mirror repository volume.

To use the High Performance Tier premium feature, you must configure a storage array as one of these:

- SHIPPED_ENABLED
- SHIPPED_ENABLED=FALSE; KEY_ENABLED=TRUE

Minimum Firmware Level

5.00

6.50 adds the `goldKey` parameter and the `mixedDriveTypes` parameter.

7.60 adds the `SSDSupport` parameter.

7.70 adds the `remoteMirror8` parameter. Firmware version 7.70 supports a maximum of eight remote mirrored pairs.

Disable Storage Array Remote Status Notification

This command turns off the remote status notification feature. The remote status notification feature enables the periodic collection of the storage array profile and the support bundle information by the persistent monitor. The storage array profile and the support bundle information are automatically sent to a support data collection web server. To turn on the remote status notification feature, use the **enable storageArray remoteStatusNotification** command.

Syntax

```
disable storageArray remoteStatusNotification
```

Parameter

None.

Minimum Firmware Level

7.70

Download Drive Firmware

This command downloads a firmware image to a drive.

 **ATTENTION Possible damage to the storage array configuration** – Downloading drive firmware incorrectly can result in damage to the drives or a loss of data access.

This command is intended for downloading a firmware image to only one drive at a time. If you use this command in a script, make sure that you use this command only once. If you use this command more than once, the operation can fail. You can download firmware images to all of the drives in a storage array at one time by using the **download storageArray driveFirmware** command.

Syntax

```
download drive [trayID,drawerID,slotID] firmware file="filename"
```

Parameters

| Parameter | Description |
|-----------|---|
| drive | The drive to which you want to download the firmware image. For high-capacity drive trays, specify the tray ID value, the drawer ID value, and the slot ID value for each drive to which you want to download firmware. For low-capacity drive trays, specify the tray ID value and the slot ID value for each drive to which you want to download firmware. Tray ID values are 0 |

| Parameter | Description |
|-----------|---|
| | to 99. Drawer ID values are 1 to 5. Slot ID values are 1 to 32. Enclose the tray ID values, the drawer ID values, and the slot ID values in brackets ([]). |
| file | The file path and the file name of the file that contains the firmware image. Enclose the file path and the file name of the firmware image in double quotation marks (" "). For example: file="C:\Program Files\CLI\dnld\drvfrm.dlp" Valid file names have a .dlp extension. |

Notes

Before trying to download drive firmware, take these precautions:

- Stop all I/O activity to the storage array before you download the firmware image. The **download drive** command blocks all I/O activity until the download finishes or fails; however, as a precaution, make sure that all I/O activity that might affect the drive is stopped.
- Make sure that the firmware image file is compatible with the drive tray. If you download a firmware image file that is not compatible with the drive tray that you have selected, the drive tray might become unusable.
- Do not make any configuration changes to the storage array while you download drive firmware. Trying to make a configuration change can cause the firmware download to fail and make the selected drives unusable.

When you download the firmware to the drives, you must provide the full path and file name to the firmware image that is stored on your system.

You can use **download drive** command to test the firmware on one drive before you install the firmware on all of the drives in a storage array. The download returns one of these statuses:

- Successful
- Unsuccessful With Reason
- Never Attempted With Reason

The **drive** parameter supports both high-capacity drive trays and low-capacity drive trays. A high-capacity drive tray has drawers that hold the drives. The drawers slide out of the drive tray to provide access to the drives. A low-capacity drive tray does not have drawers. For a high-capacity drive tray, you must specify the identifier (ID) of the drive tray, the ID of the drawer, and the ID of the slot in which a drive resides. For a low-capacity drive tray, you need only specify the ID of the drive tray and the ID of the slot in which a drive resides. For a low-capacity drive tray, an alternative method for identifying a location for a drive is to specify the ID of the drive tray, set the ID of the drawer to 0, and specify the ID of the slot in which a drive resides.

Minimum Firmware Level

6.10

7.60 adds the `drawerID` user input.

Download Environmental Card Firmware

This command downloads environmental services monitor (ESM) firmware.

Syntax

```
download (allTrays | tray [trayID])
firmware file="filename"
```

Parameters

| Parameter | Description |
|-----------|--|
| allTray | This parameter downloads new firmware to all of the trays in the storage array. |
| tray | The drive tray that contains the ESM card to which you want to load new firmware. Tray ID values are 0 to 99. Enclose the tray ID value in square brackets ([]). |
| file | The file path and the file name of the file that contains the firmware image. Enclose the file path and the file name of the firmware image in double quotation marks (" "). For example: file="C:\Program Files\CLI\dnld\esmfrm.esm" Valid file names have an .esm extension. |

Notes

The `tray` parameter downloads new firmware to a specific drive tray. If you need to download new firmware to more than one drive tray, but not all drive trays, you must enter this command for each drive tray.

Minimum Firmware Level

5.20

Download Power Supply Firmware

This command downloads firmware updates to the power supplies. You can schedule simultaneous firmware updates for several power supplies, and the power supplies can be in different trays. A single firmware file can contain updates for several different power supplies. Matching firmware updates are automatically chosen for the power supplies. Firmware download occurs only if the new firmware version is not the same as the version of the power supplies on the trays. A download succeeds only if the power supply is in an Optimal state and there is a redundant power supply that is in an Optimal state.

To bypass these checks 'forceUpdate' can be used.

Syntax

```
download (allTrays |
...tray [trayID1]...[trayIDn] |
...tray [trayID])
powerSupplyUpdate file="filename"
powerSupplyUnit [(left | right) | (top | bottom)] |
[forceUpdate]
```

Parameters

| Parameter | Description |
|------------------------|--|
| allTrays | This parameter downloads new power supply firmware to all of the trays in the storage array. |
| tray or trays | The tray that contains the power supply to which you want to download new firmware. Tray ID values are 0 to 99. Enclose the tray ID value in square brackets ([]). |
| powerSupplyUpdate file | The file path and the file name of the file that contains the firmware image. Enclose the file path and the file name of the firmware image in double quotation marks (" "). For example: file="C:\Program Files\CLI\dnld\esmfrm.esm" Valid file names have an .esm extension. |
| powerSupplyUnit | The power supply to which you want to download new firmware. Valid power supply identifiers are left , right , top , or bottom . Enclose the power-fan canister identifier in square brackets ([]). |
| forceUpdate | This parameter bypasses these checks: <ul style="list-style-type: none"> ▪ To determine if the new firmware version is the same as the existing firmware version. ▪ To determine if the power supply is in an Optimal state. ▪ To determine if there is a redundant power supply that is in an Optimal state. |

Minimum Firmware Level

7.77

Download Storage Array Drive Firmware

This command downloads firmware images to all of the drives in the storage array.

Syntax

```
download storageArray driveFirmware file="filename"  
[file="filename2"... file="filenameN"]
```

Parameter

| Parameter | Description |
|-----------|---|
| file | The file path and the file name of the file that contains the firmware image. Enclose the file path and the file name of the firmware image in double quotation marks (" "). For example: |

| Parameter | Description |
|-----------|--|
| | file="C:\Program Files\CLI\dnld\sadrvfrm.dlp" Valid file names have a .dlp extension. |

Notes

When you run this command, you can download more than one firmware image file to the drives in a storage array. The number of firmware image files that you can download depends on the storage array. The storage management software returns an error if you try to download more firmware image files than the storage array can accept.

You can schedule downloads for multiple drives at the same time, including multiple drives in a redundant volume group. Each firmware image file contains information about the drive types on which the firmware image runs. The specified firmware images can be downloaded only to a compatible drive. Use the **download drive firmware** command to download a firmware image to a specific drive.

The **download storageArray driveFirmware** command blocks all I/O activity until either download try has been made for each candidate drive or you run the **stop storageArray downloadDriveFirmware** command. When the **download storageArray driveFirmware** command finishes downloading the firmware image, each candidate drive shows the download status for each drive. One of these statuses is returned:

- Successful
- Unsuccessful With Reason
- Never Attempted With Reason

Minimum Firmware Level

5.20

Download Storage Array Firmware/NVSRAM

This command downloads firmware and, optionally, NVSRAM values for the storage array controller. If you want to download only NVSRAM values, use the **download storageArray NVSRAM** command.

Syntax

```
download storageArray firmware [, NVSRAM ]
file="filename" [, "NVSRAM-filename"]
[downgrade=(TRUE | FALSE)]
[activateNow=(TRUE | FALSE)]
```

Parameters

| Parameter | Description |
|-----------|---|
| NVSRAM | The setting to download a file with NVSRAM values when you download a firmware file. Do not include square brackets with this parameter. Include a comma after the <i>firmware</i> parameter. |

| Parameter | Description |
|------------------------|---|
| file | The file path and the file name that contains the firmware. Enclose the file path and the file name in double quotation marks (" "). For example: file="C:\Program Files\CLI\dnld\safm.dlp" Valid file names have a .dlp extension. |
| <i>NVSRAM-filename</i> | The file path and the file name that contains the NVSRAM values. Enclose the NVSRAM file name in double quotation marks (" "). For example: file="C:\Program Files\CLI\dnld\safm.dlp" Valid file names have a .dlp extension. Include a comma before the file name downloading both firmware and NVSRAM. |
| downgrade | The setting to load firmware that is a previous version. The default value is FALSE . Set the <code>downgrade</code> parameter to TRUE if you want to download an earlier version of firmware. |
| activateNow | The setting to activate the firmware image and the NVSRAM image. The default value is TRUE . If you set the <code>activateNow</code> parameter to FALSE , you must run the activate storageArray firmware command to activate the firmware values and the NVSRAM values at a later time. |

Minimum Firmware Level

5.00

Download Storage Array NVSRAM

This command downloads the NVSRAM values for the storage array controller.

Syntax

```
download storageArray NVSRAM file="filename"
```

Parameter

| Parameter | Description |
|-----------|--|
| file | The file path and the file name that contains the NVSRAM values. Enclose the NVSRAM file name in double quotation marks (" "). For example: file="C:\Program Files\CLI\dnld\afm.dlp" Valid file names have a .dlp extension. |

Minimum Firmware Level

6.10

Download Tray Configuration Settings

This command downloads the factory default settings to all of the drive trays in a storage array or to a specific drive tray in a storage array.

Syntax

```
download (allTrays | tray [trayID]) configurationSettings
file="filename"
```

Parameters

| Parameter | Description |
|-----------|--|
| allTray | This parameter downloads new firmware to all of the trays in the storage array. |
| tray | The drive tray that contains the ESM card to which you want to load new firmware. Tray ID values are 0 to 99. Enclose the tray ID value in square brackets ([]). |
| file | The file path and the file name of the file that contains the firmware image. Enclose the file path and the file name of the firmware image in double quotation marks (" "). For example: file="C:\Program Files\CLI\dnld\trayset.dlp" Valid file names have a .dlp extension. |

Notes

The `tray` parameter downloads the factory default configuration settings to a specific drive tray. If you need to download the factory default configuration settings to more than one drive tray, but not all drive trays, you must enter this command for each drive tray.

Minimum Firmware Level

7.75

Enable Controller Data Transfer

This command revives a controller that has become quiesced while running diagnostics.

Syntax

```
enable controller [(a | b)] dataTransfer
```

Parameter

| Parameter | Description |
|------------|---|
| controller | The controller that you want to revive. Valid controller identifiers are a or b , where a is the controller in slot A, and b is the controller in slot B. Enclose the controller identifier in square brackets ([]). If you do not specify a controller, the storage management software returns a syntax error. |

Minimum Firmware Level

6.10

Enable External Security Key Management

This command enables external security key management for a storage array that has full disk encryption drives.

Syntax

```
enable storageArray externalKeyManagement
file="fileName" |
passPhrase="passPhraseString"
```

Parameters

| Parameter | Description |
|------------|--|
| file | The file path and the file name that has the security key. Enclose the file path and the file name that has the security key in double quotation marks (" "). For example: file="C:\Program Files\CLI\sup\seckey.slk" IMPORTANT – The file name must have an extension of .slk. |
| passPhrase | A character string that encrypts the security key so that you can store the security key in an external file. Enclose the pass phrase character string in double quotation marks (" "). |

Notes

Your pass phrase must meet these criteria:

- The pass phrase must be between eight and 32 characters long.
- The pass phrase must contain at least one uppercase letter.
- The pass phrase must contain at least one lowercase letter.
- The pass phrase must contain at least one number.
- The pass phrase must contain at least one non-alphanumeric character, for example, < > @ +.



NOTE If your pass phrase does not meet these criteria, you will receive an error message.

Minimum Firmware Level

7.70

Enable Storage Array Feature

This command enables a premium feature by using a feature key file.



ATTENTION Before you enable the High Performance Tier premium feature, stop all host I/O operations to the storage array. When you enable the High Performance Tier premium feature, both controllers in the storage array will immediately reboot.

Syntax

```
enable storageArray [featurePack | feature]
file="filename"
```

Parameter

| Parameter | Description |
|-----------|--|
| file | The file path and the file name of a valid feature key file. Enclose the file path and the file name in double quotation marks (" "). For example: file="C:\Program Files\CLI\dnld\ftrkey.key" Valid file names for feature key files end with a .key extension. |

Notes

A premium feature is an additional application to enhance the capabilities of a storage array. The premium features are these:

- Storage partitioning
- Snapshots
- Remote Volume Mirroring
- Mixed drive types
- High performance tier
- SSD support
- SafeStore Drive Security

A feature pack is a predefined set of premium features, such as Storage Partitioning and Remote Volume Mirroring. These premium features are combined for the convenience of the users.

Minimum Firmware Level

6.10

6.50 adds the `featurePack` parameter.

7.50 adds the `highPerformanceTier` parameter.

7.70 adds the `remoteMirror8` parameter. Firmware version 7.70 supports a maximum of eight remote mirrored pairs.

Enable Storage Array Remote Status Notification

This command turns on the remote status notification feature. The remote status notification feature enables the periodic collection of the storage array profile and the support bundle information by the persistent monitor. The storage array profile and the support bundle information are automatically sent to a support data collection web server. To turn off the remote status notification feature, use the **disable storageArray remoteStatusNotification** command.

Syntax

```
enable storageArray remoteStatusNotification
```

Parameter

None.

Minimum Firmware Level

7.70

Enable Volume Group Security

This command converts a non-secure volume group to a secure volume group.

Syntax

```
enable volumeGroup [volumeGroupName] security
```

Parameter

| Parameter | Description |
|-------------|---|
| volumeGroup | The alphanumeric identifier (including - and _) of the volume group that you want to place in the Security Enabled state. Enclose the volume group identifier in square brackets ([]). |

Notes

These conditions must be met to successfully run this command.

- All drives in the volume group must be full disk encryption drives.
- The SafeStore Drive Security premium feature must be enabled.
- The storage array security key has to be set.
- The volume group is Optimal, and it does not have snapshot volumes or repository volumes.

The controller firmware creates a lock that restricts access to the FDE drives. FDE drives have a state called Security Capable. When you create a security key, the state is set to Security Enabled, which restricts access to all FDE drives that exist within the storage array.

Minimum Firmware Level

7.40

Export Storage Array Security Key

This command saves a full disk encryption (FDE) security key to a file. You can transfer the file from one storage array to another storage array. The file enables you to move FDE drives between storage arrays.

Syntax

```
export storageArray securityKey
passPhrase="passPhraseString"
file="fileName"
```

Parameters

| Parameter | Description |
|------------|---|
| passPhrase | A character string that encrypts the security key so that you can store the security key in an external file. |
| file | The file path and the file name to which you want to save the security key. For example: file="C:\Program Files\CLI\sup\seckey.slk" IMPORTANT – You must add a file extension of .slk to the end of the file name. |

Notes

The storage array to which you will be moving drives must have drives with a capacity that is equal to or greater than the drives that you are importing.

The controller firmware creates a lock that restricts access to the full disk encryption (FDE) drives. FDE drives have a state called Security Capable. When you create a security key, the state is set to Security Enabled, which restricts access to all FDE drives that exist within the storage array.

Your pass phrase must meet these criteria:

- The pass phrase must be between eight and 32 characters long.
- The pass phrase must contain at least one uppercase letter.
- The pass phrase must contain at least one lowercase letter.
- The pass phrase must contain at least one number.
- The pass phrase must contain at least one non-alphanumeric character, for example, < > @ +.



NOTE If your pass phrase does not meet these criteria, you will receive an error message and will be asked to retry the command.

Minimum Firmware Level

7.40

Import Storage Array Security Key

This command unlocks one or more full disk encryption (FDE) drives that you have imported from one storage array to another storage array. Only the FDE drives with the matching security key from the imported storage array are unlocked. After they are unlocked, the security key for the new storage array is applied.

Syntax

```
import storageArray securityKey file="fileName"
passPhrase="passPhraseString"
```

Parameters

| Parameter | Description |
|------------|---|
| file | The file path and the file name that has the original security key of the imported FDE drives. For example: file="C:\Program Files\CLI\sup\seckey.slk" IMPORTANT – The file that has the security key must have a file extension of .slk. |
| passPhrase | The character string that provides authentication for the security key. The pass phrase is 8 to 32 characters in length. You must use at least one number, one lowercase letter, one uppercase letter, and one non-alphanumeric character in the pass phrase. A space is not permitted. |

Notes

The controller firmware creates a lock that restricts access to the FDE drives. FDE drives have a state called Security Capable. When you create a security key, the state is set to Security Enabled, which restricts access to all FDE drives that exist within the storage array.

Your pass phrase must meet these criteria:

- The pass phrase must be between eight and 32 characters long.
- The pass phrase must contain at least one uppercase letter.
- The pass phrase must contain at least one lowercase letter.
- The pass phrase must contain at least one number.
- The pass phrase must contain at least one non-alphanumeric character, for example, < > @ +.



NOTE If your pass phrase does not meet these criteria, you will receive an error message and will be asked to retry the command.

Minimum Firmware Level

7.40

Load Storage Array DBM Database

This command uploads a Database Management (DBM) database image from a file. This command restores a storage array to the exact configuration that existed when the DBM database image was captured to a file using the `save storageArray dbmDatabase` command. Before using this command, you must first obtain a validator or a security code from your Customer and Technical Support representative. To obtain a validator, use the `save storageArray dbmValidator` command to generate an XML file that contains validator information. Your Customer and Technical Support representative uses the XML file to generate the validator required for this command.

Syntax

```
load storageArray dbmDatabase
file="filename" validator=validatorValue
```

Parameters

| Parameter | Description |
|-----------|---|
| file | <p>The file path and the file name of the DBM database you want to upload. Enclose the file name in double quotation marks (" "). For example:</p> <pre>file="C:\Array Backups\DBMbackup_03302010.dbm"</pre> <p>This command does not automatically append a file extension to the saved file. You must specify a file extension when entering the file name.</p> |
| validator | <p>The alphanumeric security code required to restore a storage array to an existing configuration. Use the <code>save storageArray dbmValidator</code> command to generate the required validation information XML file. After the validation information XML file is available, contact your Customer and Technical Support representative to obtain the Validator.</p> |

Notes

It might take up to 30 minutes to restore controller functionality. Depending on the size of the database image, restoring the database might take up as much as 30 minutes. The host software will not show the controllers in an Optimal state until after all actions for loading the database image are completed on the controllers.

Minimum Firmware Level

7.75

Recopy Volume Copy

This command reinitiates a volume copy operation using an existing volume copy pair.

 **ATTENTION** Starting a volume copy operation overwrites all existing data on the target volume, makes the target volume read-only to hosts, and fails all snapshot volumes associated with the target volume, if any exist. If you have used the target volume as a copy before, be sure you no longer need the data or have it backed up.

This command works with volume copy pairs that you created with a snapshot volume or without a snapshot volume.

Syntax

```
recopy volumeCopy target [targetName]
[source [sourceName]]
[copyPriority=(highest | high | medium | low | lowest)]
targetReadOnlyEnabled=(TRUE | FALSE)
copyType=(online | offline)]
```

Parameters

| Parameter | Description |
|-----------------------|---|
| target | The name of the target volume for which you want to reinitiate a volume copy operation. Enclose the target volume name in square brackets ([]). If the target volume name has special characters, you also must enclose the target volume name in double quotation marks (" "). |
| source | The name of the source volume for which you want to reinitiate a volume copy operation. Enclose the source volume name in square brackets ([]). If the source volume name has special characters, you also must enclose the source volume name in double quotation marks (" "). |
| copyPriority | The priority that the volume copy has relative to host I/O activity. Valid values are highest , high , medium , low , or lowest . |
| targetReadOnlyEnabled | The setting so that you can write to the target volume or only read from the target volume. To write to the target volume, set this parameter to FALSE . To prevent writing to the target volume, set this parameter to TRUE . |
| copyType | Use this parameter to create a volume copy with a snapshot. Creating a volume copy with a snapshot enables you to continue to write to the source volume while creating the volume copy. To reinitiate a volume copy with a snapshot, set this parameter to online . To reinitiate a volume copy with out a snapshot, set this parameter to offline . |

Notes

Copy priority defines the amount of system resources that are used to copy the data between the source volume and the target volume of a volume copy pair. If you select the highest priority level, the volume copy uses the most system resources to perform the volume copy, which decreases performance for host data transfers.

Minimum Firmware Level

6.10

7.77 adds recopying a volume copy with snapshot.

Recover RAID Volume

This command creates a RAID volume with the given properties without initializing any of the user data areas on the drives. Parameter values are derived from the Recovery Profile data file (`recoveryProfile.csv`) for the storage array. You can create the recover volume in an existing volume group or create a new volume group by using this command.



NOTE You can run this command only from a command line. You cannot run this command from the GUI script editor. You cannot use the storage management GUI to recover a volume.

Syntax

```
recover volume (drive=(trayID,drawerID,slotID) |
drives=(trayID1,drawerID1,slotID1
... trayIDn,drawerIDn,slotIDn) |
volumeGroup=volumeGroupName)
[newVolumeGroup=volumeGroupName]
userLabel=( "volumeName"
volumeWWN="volumeWWN" )
capacity=volumeCapacity
offset=offsetValue
raidLevel=(0 | 1 | 3 | 5 | 6)
segmentSize=segmentSizeValue
dssPreallocate=(TRUE | FALSE)
SSID=subsystemVolumeID
[owner=(a | b)
cacheReadPrefetch=(TRUE | FALSE)
dataAssurance=(none | enabled)]
```

```
recover volume (drive=(trayID,drawerID,slotID) |
drives=(trayID1,drawerID1,slotID1
... trayIDn,drawerIDn,slotIDn) |
volumeGroup=volumeGroupName)
[newVolumeGroup=volumeGroupName]
userLabel=( "volumeName"
volumeWWN="volumeWWN" )
capacity=volumeCapacity
offset=offsetValue
raidLevel=(0 | 1 | 3 | 5 | 6)
segmentSize=segmentSizeValue
dssPreallocate=(TRUE | FALSE)
SSID=subsystemVolumeID
[owner=(a | b)
cacheReadPrefetch=(TRUE | FALSE)
dataAssurance=(none | enabled)]
```

Parameters

| Parameter | Description |
|-----------------|--|
| drive or drives | The drives that you want to assign to the volume group that will contain the volume that you want to recover. For high-capacity drive trays, specify the tray ID value, the drawer ID value, and the slot ID value for each drive that you assign to the volume. For low-capacity drive trays, specify the tray ID value and the slot ID value for each drive that you assign to the volume. Tray ID values are 0 to 99. Drawer ID values are 1 to 5. Slot ID values are 1 to 32. Enclose the tray ID values, the drawer ID values, and the slot ID values in square brackets ([]). |
| volumeGroup | The name of an existing volume group in which you want to create the volume. (To determine the names of the volume groups in your storage array, run the show storageArray profile command.) |
| newVolumeGroup | The name that you want to give a new volume group. Enclose the new volume group name in double quotation marks (" "). |
| userLabel | The name of the volume that you want to recover. Enclose the volume name in double quotation marks (" "). |
| volumeWWN | The world wide name of the volume that you want to recover. The name is a 16 byte identifier, for example, 60080E500017B4320000000049887D77. Enclose the identifier in double quotation marks (" "). |
| capacity | The size of the volume that you are adding to the storage array. Size is defined in units of bytes , KB , MB , GB , or TB . |
| offset | The number of blocks from the start of the volume group to the start of the referenced volume. |
| raidLevel | The RAID level of the volume group that contains the drives. Valid values are 0, 1, 3, 5, or 6. |
| segmentSize | The amount of data (in KB) that the controller writes on a single drive in a volume group before writing data on the next drive. Valid values are 8, 16, 32, 64, 128, 256, or 512. |
| dssPreallocate | The setting to turn on or turn off allocating volume storage capacity for future segment size changes. To turn on allocation, set this parameter to TRUE . To turn off allocation, set this parameter to FALSE . |

| Parameter | Description |
|-------------------|---|
| SSID | The storage array subsystem identifier of a volume. Use the show volume command to determine the storage array subsystem identifier. |
| owner | The controller that owns the volume. Valid controller identifiers are a or b , where a is the controller in slot A, and b is the controller in slot B. If you do not specify an owner, the controller firmware determines the owner. |
| cacheReadPrefetch | The setting to turn on or turn off cache read prefetch. To turn off cache read prefetch, set this parameter to FALSE . To turn on cache read prefetch, set this parameter to TRUE . |
| dataAssurance | The setting to specify that a volume group, and the volumes within the volume group, has data assurance protection to make sure that the data maintains its integrity. When you use this parameter, only protected drives can be used for the volume group. These settings are valid: <ul style="list-style-type: none"> ▪ none – The volume group does not have data assurance protection. ▪ enabled – The volume group has data assurance protection. The volume group supports protected information and is formatted with protection information enabled. |
| dataAssurance | The setting to specify that a volume group, and the volumes within the volume group, has data assurance protection to make sure that the data maintains its integrity. When you use this parameter, only protected drives can be used for the volume group. These settings are valid: <ul style="list-style-type: none"> ▪ none – The volume group does not have data assurance protection. ▪ enabled – The volume group has data assurance protection. The volume group supports protected information and is formatted with protection information enabled. |

Notes

The storage management software collects recovery profiles of the monitored storage arrays and saves the profiles on a storage management station.

The `drive` parameter supports both high-capacity drive trays and low-capacity drive trays. A high-capacity drive tray has drawers that hold the drives. The drawers slide out of the drive tray to provide access to the drives. A low-capacity drive tray does not have drawers. For a high-capacity drive tray, you must specify the identifier (ID) of the drive tray, the ID of the drawer, and the ID of the slot in which a drive resides. For a

low-capacity drive tray, you need only specify the ID of the drive tray and the ID of the slot in which a drive resides. For a low-capacity drive tray, an alternative method for identifying a location for a drive is to specify the ID of the drive tray, set the ID of the drawer to 0, and specify the ID of the slot in which a drive resides.

If you attempt to recover a volume using the `drive` parameter or the `drives` parameter and the drives are in an unassigned state, the controller automatically creates a new volume group. Use the `newVolumeGroup` parameter to specify a name for the new volume group.

You can use any combination of alphanumeric characters, underscore (`_`), hyphen (`-`), and pound (`#`) for the names. Names can have a maximum of 30 characters.

The `owner` parameter defines which controller owns the volume. The preferred controller ownership of a volume is the controller that currently owns the volume group.

Preallocating Storage Capacity

The `dssPreallocate` parameter enables you to assign capacity in a volume for storing information that is used to rebuild a volume. When you set the `dssPreallocate` parameter to **TRUE**, the storage space allocation logic in the controller firmware preallocates the space in a volume for future segment size changes. The preallocated space is the maximum allowable segment size. The `dssPreallocate` parameter is necessary for properly recovering volume configurations that are not retrievable from the controller data base. To turn off the preallocation capability, set `dssPreallocate` to **FALSE**.

Segment Size

The size of a segment determines how many data blocks that the controller writes on a single drive in a volume before writing data on the next drive. Each data block stores 512 bytes of data. A data block is the smallest unit of storage. The size of a segment determines how many data blocks that it contains. For example, an 8-KB segment holds 16 data blocks. A 64-KB segment holds 128 data blocks.

When you enter a value for the segment size, the value is checked against the supported values that are provided by the controller at run time. If the value that you entered is not valid, the controller returns a list of valid values. Using a single drive for a single request leaves other drives available to simultaneously service other requests.

If the volume is in an environment where a single user is transferring large units of data (such as multimedia), performance is maximized when a single data transfer request is serviced with a single data stripe. (A data stripe is the segment size that is multiplied by the number of drives in the volume group that are used for data transfers.) In this case, multiple drives are used for the same request, but each drive is accessed only once.

For optimal performance in a multiuser database or file system storage environment, set your segment size to minimize the number of drives that are required to satisfy a data transfer request.

Cache Read Prefetch

Cache read prefetch lets the controller copy additional data blocks into cache while the controller reads and copies data blocks that are requested by the host from disk into cache. This action increases the chance that a future request for data can be fulfilled from cache. Cache read prefetch is important for multimedia applications that use sequential data transfers. The configuration settings for the storage array that you use determine the number of additional data blocks that the controller reads into cache. Valid values for the `cacheReadPrefetch` parameter are **TRUE** or **FALSE**.

Minimum Firmware Level

5.43

7.10 adds RAID 6 Level capability and the `newVolumeGroup` parameter.

7.60 adds the `drawerID` user input.

7.75 adds the `dataAssurance` parameter.

Re-create External Security Key

This command regenerates a storage array security key for use with the external security key management feature.

Syntax

```
recreate storageArray securityKey
passPhrase="passPhraseString"
file="fileName"
```

Parameters

| Parameter | Description |
|-------------------------|---|
| <code>passPhrase</code> | A character string that encrypts the security key so that you can store the security key in an external file. |
| <code>file</code> | The file path and the file name that has the security key. For example: <code>file="C:\Program Files\CLI\sup\seckey.slk"</code> IMPORTANT – The file name must have an extension of <code>.slk</code> . |

Notes

Your pass phrase must meet these criteria:

- The pass phrase must be between eight and 32 characters long.
- The pass phrase must contain at least one uppercase letter.
- The pass phrase must contain at least one lowercase letter.
- The pass phrase must contain at least one number.
- The pass phrase must contain at least one non-alphanumeric character, for example, `<` `>` `@` `+`.



NOTE If your pass phrase does not meet these criteria, you will receive an error message.

Minimum Firmware Level

7.70

Re-create Remote Volume Mirroring Repository Volume



NOTE With firmware version 7.80, the `recreate storageArray mirrorRepository` command is deprecated. This command is no longer supported in either the GUI or the CLI. If you attempts to run this command, an error message will be returned indicating that this functionality is no longer supported and that no changes will be made to the specified remote mirror repositories.

This command creates a new Remote Volume Mirroring repository volume (also called a mirror repository volume) by using the parameters defined for a previous mirror repository volume. The underlying requirement is that you have previously created a mirror repository volume. When you use this command, you can define the mirror repository volume in one of three ways: user-defined drives, user-defined volume group, or user-defined number of drives for the mirror repository volume. If you choose to define a number of drives, the controller firmware chooses which drives to use for the mirror repository volume.

Syntax (User-Defined Drives)

```
recreate storageArray mirrorRepository
repositoryRAIDLevel=(1 | 3 | 5 | 6)
repositoryDrives=(trayID1,slotID1 ... trayIDn,slotIDn)
[trayLossProtect=(TRUE | FALSE)
dataAssurance=(none | enabled)]
```

```
recreate storageArray mirrorRepository
repositoryRAIDLevel=(1 | 3 | 5 | 6)
repositoryDrives=(trayID1,slotID1 ... trayIDn,slotIDn)
[trayLossProtect=(TRUE | FALSE)
dataAssurance=(none | enabled)]
```

Syntax (User-Defined Volume Group)

```
recreate storageArray mirrorRepository
repositoryVolumeGroup=volumeGroupName [freeCapacityArea=freeCapacityIndexNumber]
```

Syntax (User-Defined Number of Drives)

```
recreate storageArray mirrorRepository
repositoryRAIDLevel=(1 | 3 | 5 | 6)
repositoryDriveCount=numberOfDrives
[driveType=(fibre | SATA | SAS)]
[trayLossProtect=(TRUE | FALSE)
dataAssurance=(none | enabled)]
```

```
recreate storageArray mirrorRepository
repositoryRAIDLevel=(1 | 3 | 5 | 6)
repositoryDriveCount=numberOfDrives
[driveType=(fibre | SATA | SAS)]
[trayLossProtect=(TRUE | FALSE)
dataAssurance=(none | enabled)]
```

Parameters

| Parameter | Description |
|---------------------|--|
| repositoryRAIDLevel | The RAID level for the mirror repository volume. Valid values are 1, 3, 5, or 6. |
| repositoryDrives | The drives for the mirror repository volume. Specify the tray ID and slot ID for each drive that you assign to the mirror repository volume. Tray ID values are 0 to 99. Slot ID values are 1 to 32. Enclose the tray ID values and the slot ID values in parentheses. |

| Parameter | Description |
|-----------------------|--|
| repositoryVolumeGroup | The name of the volume group where the mirror repository volume is located. |
| freeCapacityArea | <p>The index number of the free space in an existing volume group that you want to use to re-create the mirror repository volume. Free capacity is defined as the free capacity between existing volumes in a volume group. For example, a volume group might have the following areas: volume 1, free capacity, volume 2, free capacity, volume 3, free capacity. To use the free capacity following volume 2, you would specify:</p> <pre>freeCapacityArea=2</pre> <p>Run the show volumeGroup command to determine if a free capacity area exists.</p> |
| repositoryDriveCount | The number of unassigned drives that you want to use for the mirror repository volume. |
| driveType | <p>The type of drive that you want to use for the mirror repository volume. You cannot mix drive types. You must use this parameter when you have more than one type of drive in your storage array. Valid drive types are :</p> <ul style="list-style-type: none"> ▪ fibre ▪ SATA ▪ SAS <p>If you do not specify a drive type, the command defaults to fibre.</p> |
| trayLossProtect | The setting to enforce tray loss protection when you create the mirror repository volume. To enforce tray loss protection, set this parameter to TRUE . The default value is FALSE . |
| dataAssurance | <p>The setting to specify that a volume group, and the volumes within the volume group, has data assurance protection to make sure that the data maintains its integrity. When you use this parameter, only protected drives can be used for the volume group. These settings are valid:</p> <ul style="list-style-type: none"> ▪ none – The volume group does not have data assurance protection. ▪ enabled – The volume group has data assurance protection. The volume group supports protected information and is formatted with protection information enabled. |

| Parameter | Description |
|---------------|--|
| dataAssurance | <p>The setting to specify that a volume group, and the volumes within the volume group, has data assurance protection to make sure that the data maintains its integrity. When you use this parameter, only protected drives can be used for the volume group. These settings are valid:</p> <ul style="list-style-type: none"> ▪ none – The volume group does not have data assurance protection. ▪ enabled – The volume group has data assurance protection. The volume group supports protected information and is formatted with protection information enabled. |

Notes

If you enter a value for the storage space of the mirror repository volume that is too small, the controller firmware returns an error message, which states the amount of space that is needed for the mirror repository volume. The command does not try to change the mirror repository volume. You can re-enter the command by using the value from the error message for the storage space value of the mirror repository volume.

When you assign the drives, if you set the `trayLossProtect` parameter to **TRUE** and have selected more than one drive from any one tray, the storage array returns an error. If you set the `trayLossProtect` parameter to **FALSE**, the storage array performs operations, but the mirror repository volume that you create might not have tray loss protection.

When the controller firmware assigns the drives, if you set the `trayLossProtect` parameter to **TRUE**, the storage array returns an error if the controller firmware cannot provide drives that result in the new mirror repository volume having tray loss protection. If you set the `trayLossProtect` parameter to **FALSE**, the storage array performs the operation even if it means that the mirror repository volume might not have tray loss protection.

Minimum Firmware Level

6.10

7.10 adds RAID Level 6 capability

7.75 adds the `dataAssurance` parameter.

Re-create Snapshot

This command starts a fresh copy-on-write operation by using an existing snapshot volume. You can re-create a single snapshot volume or re-create multiple snapshot volumes. If you choose to re-create multiple snapshot volumes, you can re-create from two to the maximum number of snapshot volumes that your storage array can support.

Syntax

```
recreate snapshot (volume [volumeName] |
volumes [volumeName1 ... volumeNameN])
[userLabel="snapshotVolumeName"
warningThresholdPercent=percentValue
```

```
repositoryFullPolicy (failBaseWrites | failSnapshot)]
```

Parameters

| Parameter | Description |
|-------------------------|---|
| volume or volumes | The name of the specific volume for which you want to start a fresh copy-on-write operation. You can enter more than one volume name. Enclose the volume name in square brackets ([]). If the volume name has special characters, you must also enclose the volume name in double quotation marks (" "). |
| userLabel | The name of the snapshot volume. Enclose the snapshot volume name in double quotation marks (" "). If you enter more than one snapshot volume name, this command fails. |
| warningThresholdPercent | The percentage of repository capacity at which you receive a warning that the snapshot repository volume is nearing full. Use integer values. For example, a value of 70 means 70 percent. The default value is 50. |
| repositoryFullPolicy | The type of processing that you want to continue if the snapshot repository volume is full. You can choose to fail writes to the base volume (failBaseWrites) or fail writes to the snapshot volume (failSnapshot). The default value is failSnapshot . |

Notes

You can use any combination of alphanumeric characters, underscore (_), hyphen (-), and pound (#) for the names. Names can have a maximum of 30 characters.

If you do not specify a value for the `warningThresholdPercent` parameter or the `repositoryFullPolicy` parameter, the previously set value is used.

Recreating a Single Snapshot Volume or Multiple Snapshot Volumes with Optional Parameters

- If you specify one or more of the optional parameters, the re-create operation processes each snapshot volume separately.
- If you try to use the same user label for more than one volume, the command will fail.
- If you do not set the `warningThresholdPercent` parameter or the `repositoryFullPolicy` parameter, values that you previously set are used.

Recreating Multiple Snapshot Volumes without Optional Parameters

- If you list multiple snapshot volumes to be re-created but do not specify any of the optional parameters, the re-create operation processes the snapshot volumes as a "batch" process.

- Validation checks for the necessary snapshot-restarted preconditions are performed before restarting any snapshot. If any of the listed snapshot volumes fail the validation, the entire command fails and the snapshot volumes are not re-created. If the validation is successful for all of the snapshot volumes in the list, but one or more of the snapshots in the list fails to restart, the entire command fails and none of the snapshots are re-created.
- During snapshot re-creation, all affected volumes (snapshots, base, and repository) are appropriately quiesced and I/O operations are resumed to all affected volumes after all snapshots have been successfully re-created.

Minimum Firmware Level

5.00

Remove Remote Mirror

This command removes the mirror relationship between the primary volume and the secondary volume in a remote-mirrored pair.

Syntax

```
remove remoteMirror (localVolume [volumeName] |
localVolumes [volumeName1 ... volumeNameN])
```

Parameter

| Parameter | Description |
|--------------------------------|--|
| localVolume or localVolumes | The name of the primary volume (the volume on the local storage array) that you want to remove. You can enter more than one volume name. Enclose the volume name in square brackets ([]). If the volume name has special characters, you also must enclose the volume name in double quotation marks (" "). |

Minimum Firmware Level

6.10

Remove Volume Copy

This command removes a volume copy pair.

Syntax

```
remove volumeCopy target [targetName]
[source [sourceName]
copyType=(online | offline)]
```

Parameters

| Parameter | Description |
|-----------|---|
| target | The name of the target volume that you want to remove. Enclose the target volume name in square brackets ([]). If the target volume name has special characters, you also must enclose the target volume name in double quotation marks (" "). |
| source | The name of the source volume that you want to remove. Enclose the source volume name in square brackets ([]). If the source volume name has special characters, you also must enclose the source volume name in double quotation marks (" "). |
| copyType | Use this parameter to identify that a volume copy has a snapshot. If the volume copy has a snapshot, set this parameter to online . If the volume copy does not have a snapshot, set this parameter to offline . |

Minimum Firmware Level

5.40

7.77 adds creating a volume copy with snapshot.

Remove Volume LUN Mapping

This command removes the logical unit number (LUN) mapping from one or more volumes.

Syntax

```
remove (allVolumes | volume [volumeName] |
volumes [volumeName1 ... volumeNameN] | accessVolume)
lunMapping (host="hostName" |
hostGroup=("hostGroupName" | defaultGroup))
```

Parameters

| Parameter | Description |
|-------------------|---|
| allVolumes | This parameter removes the LUN mapping from all of the volumes. |
| volume or volumes | The name of the specific volume that you want to remove from the LUN mapping. You can enter more than one volume name. Enclose the volume name in double quotation marks (" ") inside of square brackets ([]). |
| accessVolume | This parameter removes the access volume. |
| host | The name of the host to which the volume is mapped. Enclose the host name in double quotation marks (" "). |

| Parameter | Description |
|-----------|---|
| hostGroup | The name of the host group that contains the host to which the volume is mapped. Enclose the host group name in double quotation marks (" "). The defaultGroup value is the host group that contains the host to which the volume is mapped. |

Notes

The access volume is the volume in a SAN environment that is used for communication between the storage management software and the storage array controller. The access volume uses a LUN address and consumes 20 MB of storage space that is not available for application data storage. An access volume is required only for in-band managed storage arrays.

 **ATTENTION Removing an access volume can damage your configuration** – The agent uses the access volumes to communicate with a storage array. If you remove an access volume mapping for a storage array from a host that has an agent running on it, the storage management software is no longer able to manage the storage array through the agent.

You must use the `host` parameter and the `hostGroup` parameter when you specify a non-access volume or an access volume. The Script Engine ignores the `host` parameter or the `hostGroup` parameter when you use the `allVolumes` parameter or the `volumes` parameter.

Minimum Firmware Level

6.10

Repair Volume Parity

This command repairs the parity errors on a volume.

Syntax

```
repair volume [volumeName] parity
parityErrorFile="filename"
[verbose=(TRUE | FALSE)]
```

Parameters

| Parameter | Description |
|-----------------|---|
| volume | The name of the specific volume for which you want to repair parity. Enclose the volume name in square brackets ([]). If the volume name has special characters, you also must enclose the volume name in double quotation marks (" "). |
| parityErrorFile | The file path and the file name that contains the parity error information that you use to repair the errors. Enclose the file name in double quotation marks (" "). For example: file="C:\Program Files\CLI\sup\parfile.txt" |

| Parameter | Description |
|-----------|---|
| verbose | The setting to capture progress details, such as percent complete, and to show the information as the volume parity is being repaired. To capture progress details, set this parameter to TRUE . To prevent capturing progress details, set this parameter to FALSE . |

Minimum Firmware Level

6.10

Replace Drive

This command redefines the composition of a volume group. You can use this command to replace a drive with either an unassigned drive or a fully integrated hot spare.

Syntax

```
replace drive([trayID,drawerID,slotID] | <"wwID">)
replacementDrive=trayID,drawerID,slotID
```

Parameters

| Parameter | Description |
|------------------|---|
| drive | The location of the drive that you want to reconstruct. For high-capacity drive trays, specify the tray ID value, the drawer ID value, and the slot ID value of the drive that you want to revive. For low-capacity drive trays, specify the tray ID value and the slot ID value of the drive that you want to revive. Tray ID values are 0 to 99. Drawer ID values are 1 to 5. Slot ID values are 1 to 32. Enclose the tray ID value, the drawer ID value, and the slot ID value in square brackets ([]). |
| replacementDrive | The location of the drive that you want to use for a replacement. For high-capacity drive trays, specify the tray ID value, the drawer ID value, and the slot ID value for the drive. For low-capacity drive trays, specify the tray ID value and the slot ID value for the drive. Tray ID values are 0 to 99. Drawer ID values are 1 to 5. Slot ID values are 1 to 32. |

Notes

The `drive` parameter supports both high-capacity drive trays and low-capacity drive trays. A high-capacity drive tray has drawers that hold the drives. The drawers slide out of the drive tray to provide access to the drives. A low-capacity drive tray does not have drawers. For a high-capacity drive tray, you must specify the identifier (ID) of the drive tray, the ID of the drawer, and the ID of the slot in which a drive resides. For a low-capacity drive tray, you need only specify the ID of the drive tray and the ID of the slot in which a drive resides. For a low-capacity drive tray, an alternative method for identifying a location for a drive is to specify the ID of the drive tray, set the ID of the drawer to 0, and specify the ID of the slot in which a drive resides.

Minimum Firmware Level

7.10

7.60 adds the `drawerID` user input.

Reset Controller

This command resets a controller, and it is disruptive to I/O operations.

 **ATTENTION** When you reset a controller, the controller is removed from the data path and is not available for I/O operations until the reset operation is complete. If a host is using volumes that are owned by the controller being reset, the I/O directed to the controller is rejected. Before resetting the controller, either make sure that the volumes that are owned by the controller are not in use or make sure that a multi-path driver is installed on all of the hosts that use these volumes.

Syntax

```
reset controller [(a | b)]
```

Parameter

| Parameter | Description |
|------------|--|
| controller | The controller that you want to reset. Valid controller identifiers are a or b , where a is the controller in slot A, and b is the controller in slot B. Enclose the controller identifier in square brackets ([]). If you do not specify a controller owner, the controller firmware returns a syntax error. |

Notes

The controller that receives the reset controller command resets the controller specified. For example, if the reset controller command is sent to controller A to request a reset of controller A, then controller A reboots itself by doing a soft reboot. If the reset controller command is sent to controller A to request a reset of controller B, then controller A holds controller B in reset and then releases controller B from reset, which is a hard reboot. A soft reboot in some products only resets the IOC chip. A hard reboot resets both the IOC and the expander chips in the controller.

Minimum Firmware Level

5.20

Reset Storage Array Battery Install Date

This command resets the age of the batteries in a storage array to zero days. You can reset the age of the batteries for an entire storage array or the age of a battery in a specific controller or in a specific battery pack.

Syntax

```
reset storageArray batteryInstallDate
(controller=[(a | b)] | batteryPack [left | right])
```

Parameters

| Parameter | Description |
|--------------------------|--|
| <code>controller</code> | The controller that contains the battery for which you want to reset the age. Valid controller identifiers are a or b , where a is the controller in slot A, and b is the controller in slot B. Use the <code>controller</code> parameter only for controllers with batteries. |
| <code>batteryPack</code> | The battery pack contains both a left battery and a right battery. Valid identifiers are left or right , where left is the battery that supports the controller in slot A, and right is the battery that supports the controller in slot B. Use the <code>batteryPack</code> parameter only for controller trays with battery packs. |

Notes

A controller might have a battery associated with it, so the controller is identified as either **a** or **b**. With the release of the CE7900 controller tray, battery packs inside the interconnect-battery canister are identified as either **left** or **right**. If the command statement uses the wrong parameter, an error appears.

Minimum Firmware Level

6.10

7.15 adds the ability to reset the battery installation dates on the left battery or the right battery in the CE6998-series controllers or the CE7900-series controllers.

Reset Storage Array Diagnostic Data

This command resets the NVSRAM that contains the diagnostic data for the storage array. This command does not delete the diagnostic data. This command replaces the Needs Attention status with the Diagnostic Data Available status. The old diagnostic data is written over automatically when new data is captured. The memory that contains the diagnostic data is also cleared when the controllers reboot. Before you reset the diagnostic data, use the `save storageArray diagnosticData` command to save the diagnostic data to a file.



ATTENTION Run this command only with the assistance of your Customer and Technical Support representative.

Syntax

```
reset storageArray diagnosticData
```

Parameters

None.

Minimum Firmware Level

6.16

Reset Storage Array Infiniband Statistics Baseline

This command resets the Infiniband statistics baseline to 0 for the storage array.

Syntax

```
reset storageArray ibStatsBaseline
```

Parameters

None.

Notes

This command does not actually reset the raw counts maintained in the hardware and firmware. Instead, the firmware creates a snapshot of the current counter values and uses these values to report differences in the counts when the statistics are retrieved. The new baseline time is applied to both controllers so that the controller counts are synchronized with each other. If one controller resets without the other controller resetting, the counters are no longer synchronized. The client becomes aware that the controllers are not synchronized because the timestamp data reported along with the statistics is not the same for both controllers.

Minimum Firmware Level

7.10

Reset Storage Array iSCSI Baseline

This command resets the iSCSI baseline to 0 for the storage array.

Syntax

```
reset storageArray iscsiStatsBaseline
```

Parameters

None.

Notes

This command resets the baseline to 0 for both controllers in the storage array. The purpose of resetting both of the controller baselines is to help make sure that the controller counts are synchronized between the controllers. If one controller resets but the second controller does not reset, the host is informed that the controllers are out of synchronization. The host is informed by the time stamps that are reported with the statistics.

Minimum Firmware Level

7.10

Reset Storage Array RLS Baseline

This command resets the read link status (RLS) baseline for all devices by setting all of the RLS counts to 0.

Syntax

```
reset storageArray RLSBaseline
```

Parameters

None.

Minimum Firmware Level

5.00

Reset Storage Array SAS PHY Baseline

This command resets the SAS physical layer (SAS PHY) baseline for all devices except the drives, and removes the list of errors from the `.csv` file. The `.csv` file is generated when you run the `save storageArray SASPHYCounts` command.



NOTE The `reset storageArray SASPHYBaseline` command clears error counts for all devices except the drives. After you run this command, the `.csv` file will continue to list the `DrivePHY` errors. All other errors are deleted from the `.csv` file.

Syntax

```
reset storageArray SASPHYBaseline
```

Parameters

None.

Minimum Firmware Level

6.10

Reset Storage Array SOC Baseline

This command resets the baseline for all switch-on-a-chip (SOC) devices that are accessed through the controllers. This command resets the baseline by setting all of the SOC counts to 0. This command is valid only for Fibre Channel devices in an arbitrated loop topology.

Syntax

```
reset storageArray SOCBaseline
```

Parameters

None.

Minimum Firmware Level

6.16

Reset Storage Array Volume Distribution

This command reassigns (moves) all of the volumes to their preferred controller.

Syntax

```
reset storageArray volumeDistribution
```

Parameters

None.

Notes

If you use this command on a host without a multi-path driver, you must stop I/O operations to the volumes until this command has completed to prevent application errors.

Under certain host operating system environments, you might be required to reconfigure the multi-path host driver. You might also need to make operating system modifications to recognize the new I/O path to the volumes.

Minimum Firmware Level

5.20

Resume Remote Mirror

This command resumes a suspended Remote Volume Mirroring operation.

Syntax

```
resume remoteMirror (primary [volumeName] |
primaries [volumeName1 ... volumeNameN])
[writeConsistency=(TRUE | FALSE)]
```

Parameters

| Parameter | Description |
|----------------------|---|
| primary or primaries | The name of the primary volume for which you want to resume operation. You can enter more than one primary volume name. Enclose the primary volume name in square brackets ([]). If the primary volume name has special characters, you also must enclose the primary volume name in double quotation marks (" "). |
| writeConsistency | The setting to identify the volumes in this command that are in a write-consistency group or are separate. For the volumes to be in the same write-consistency group, set this parameter to TRUE . For the volumes to be separate, set this parameter to FALSE . |

Notes

If you set the `writeConsistency` parameter to **TRUE**, the volumes must be in a write-consistency group (or groups). This command resumes all write-consistency groups that contain the volumes. For example, if volumes A, B, and C are in a write-consistency group and they have remote counterparts A', B', and C', the **resume remoteMirror volume ["A"] writeConsistency=TRUE** command resumes A-A', B-B', and C-C'.

Minimum Firmware Level

6.10

Resume Snapshot Rollback

This command resumes a rollback operation that has entered a paused state. A rollback operation can enter a paused state due to processing errors, which will trigger a Needs Attention condition for the storage array.

If the rollback operation cannot be resumed, the selected snapshot volume reverts to a paused state, and the Needs Attention condition is displayed.

Syntax

```
resume rollback volume [snapshotVolumeName]
```

Parameter

| Parameter | Description |
|-----------|--|
| volume | The name of the specific snapshot volume for which you want to resume a rollback operation. Enclose the snapshot volume name in square brackets ([]). If the snapshot volume name has special characters, you must also enclose the snapshot volume name in double quotation marks (" "). |

Minimum Firmware Level

7.80

Revive Drive

This command forces the specified drive to the Optimal state.

 **ATTENTION Possible loss of data access** – Correct use of this command depends on the data configuration on all of the drives in the volume group. Never try to revive a drive unless you are supervised by your Customer and Technical Support representative.

Syntax

```
revive drive [trayID,drawerID,slotID]
```

Parameter

| Parameter | Description |
|-----------|--|
| drive | The location of the drive that you want to revive. For high-capacity drive trays, specify the tray ID value, the drawer ID value, and the slot ID value of the drive that you want to revive. For low-capacity drive trays, specify the tray ID value and the slot ID value of the drive that you want to revive. Tray ID values are 0 to 99. Drawer ID values are 1 to 5. Slot ID values are 1 to 32. Enclose the tray ID value, drawer ID value, and the slot ID value in square brackets ([]). |

Notes

The `drive` parameter supports both high-capacity drive trays and low-capacity drive trays. A high-capacity drive tray has drawers that hold the drives. The drawers slide out of the drive tray to provide access to the drives. A low-capacity drive tray does not have drawers. For a high-capacity drive tray, you must specify the identifier (ID) of the drive tray, the ID of the drawer, and the ID of the slot in which a drive resides. For a low-capacity drive tray, you need only specify the ID of the drive tray and the ID of the slot in which a drive resides. For a low-capacity drive tray, an alternative method for identifying a location for a drive is to specify the ID of the drive tray, set the ID of the drawer to 0, and specify the ID of the slot in which a drive resides.

Minimum Firmware Level

5.43

7.60 adds the `drawerID` user input.

Revive Volume Group

This command forces the specified volume group and its associated failed drives to the Optimal state.

 **ATTENTION Possible loss of data access** – Correct use of this command depends on the data configuration on all of the drives in the volume group. Never try to revive a drive unless you are supervised by your Customer and Technical Support representative.

Syntax

```
revive volumeGroup [volumeGroupName]
```

Parameter

| Parameter | Description |
|-------------|---|
| volumeGroup | The alphanumeric identifier (including - and _) of the volume group to be set to the Optimal state. Enclose the volume group identifier in square brackets ([]). |

Minimum Firmware Level

6.10

Save Controller NVSRAM

This command saves a copy of the controller NVSRAM values to a file. This command saves all of the regions.

Syntax

```
save controller [(a | b)] NVSRAM file="filename"
```

Parameters

| Parameter | Description |
|------------|--|
| controller | The controller with the NVSRAM values that you want to save. Valid controller identifiers are a or b , where a is the controller in slot A, and b is the controller in slot B. Enclose the controller identifier in square brackets ([]). |
| file | The file path and the file name to which you want to save the NVSRAM values. Enclose the NVSRAM file name in double quotation marks (" "). For example: file="C:\Program Files\CLI\logs\nvsramb.txt" This command does not automatically append a file extension to the saved file. You must specify a file extension when entering the file name. |

Minimum Firmware Level

6.10

Save Drive Channel Fault Isolation Diagnostic Status

This command saves the drive channel fault isolation diagnostic data that is returned from the **start driveChannel faultDiagnostics** command. You can save the diagnostic data to a file as standard text or as XML.

See "[Start Drive Channel Fault Isolation Diagnostics](#)" for more information.

Syntax

```
save driveChannel faultDiagnostics file="filename"
```

Parameter

| Parameter | Description |
|-----------|---|
| file | The file path and the file name to which you want to save the results of the fault isolation diagnostics test on the drive channel. Enclose the file name in double quotation marks (" "). For example: file="C:\Program Files\CLI\sup\fltdiag.bin" This command does not automatically append a file extension to the saved file. You must specify a file extension when entering the file name. |

Notes

A file extension is not automatically appended to the saved file. You must specify the applicable format file extension for the file. If you specify a file extension of `.txt`, the output will be in a text file format. If you specify a file extension of `.xml`, the output will be in an XML file format.

Minimum Firmware Level

7.15 introduces this new capability for the CE7900 controller tray.

Save Drive Log

This command saves the log sense data to a file. Log sense data is maintained by the storage array for each drive.

Syntax

```
save allDrives logFile="filename"
```

Parameter

| Parameter | Description |
|-----------|---|
| logFile | The file path and the file name to which you want to save the log sense data. Enclose the file name in double quotation marks (" "). For example: file="C:\Program Files\CLI\logs\lgsendat.txt" This command does not automatically append a file extension to the saved file. You must specify a file extension when entering the file name. |

Minimum Firmware Level

6.10

Save Storage Array Configuration

This command creates a script file that you can use to re-create the current storage array volume configuration.

Syntax

```
save storageArray configuration file="filename"
[(allconfig | globalSettings=(TRUE | FALSE)
volumeConfigAndSettings=(TRUE | FALSE)
hostTopology=(TRUE | FALSE)
lunMappings=(TRUE | FALSE))]
```

Parameters

| Parameter | Description |
|-------------------------|--|
| file | The file path and the file name to which you want to save the configuration settings. Enclose the file name in double quotation marks (" "). For example: file="C:\Program Files\CLI\logs\nsaconf.cfg" This command does not automatically append a file extension to the saved file. You must specify a file extension when entering the file name. |
| allConfig | The setting to save all of the configuration values to the file. (If you choose this parameter, all of the configuration parameters are set to TRUE .) |
| globalSettings | The setting to save the global settings to the file. To save the global settings, set this parameter to TRUE . To prevent saving the global settings, set this parameter to FALSE . The default value is TRUE . |
| volumeConfigAndSettings | The setting to save the volume configuration settings and all of the global settings to the file. To save the volume configuration settings and global settings, set this parameter to TRUE . To prevent saving the volume configuration settings and global settings, set this parameter to FALSE . The default value is TRUE . |
| hostTopology | The setting to save the host topology to the file. To save the host topology, set this parameter to TRUE . To prevent saving the host topology, set this parameter to FALSE . The default value is FALSE . |
| lunMappings | The setting to save the LUN mapping to the file. To save the LUN mapping, set this parameter to TRUE . To prevent saving the LUN mapping, set this parameter to FALSE . The default value is FALSE . |

Notes

When you use this command, you can specify any combination of the parameters for the global setting, the volume configuration setting, the host topology, or the LUN mapping. If you want to enter all settings, use the `allConfig` parameter. The parameters are all optional.

Minimum Firmware Level

6.10

Save Storage Array DBM Database

This command saves the current state of the storage array's Database Management (DBM) database into a local file. The output file that is produced can be used as the input file for the `save storageArray dbmValidator` and the `load storageArray dbmDatabase` commands.

Syntax

```
save storageArray dbmDatabase file="filename"
```

Parameter

| Parameter | Description |
|-----------|--|
| file | <p>The file path and the file name of the DBM database you want to save. Enclose the file name in double quotation marks (" "). For example:</p> <pre>file="C:\Array Backups \DBMbackup_03302010.dbm"</pre> <p>This command does not automatically append a file extension to the saved file. You must specify a file extension when entering the file name.</p> |

Minimum Firmware Level

7.75

Save Storage Array DBM Validator

This command saves a storage array's Database Management (DBM) validation information in an XML file, which can be used by a Customer and Technical Support representative to generate a security code or Validator. The Validator must be included in the `load storageArray dbmDatabase` command when restoring a storage array back to a pre-existing configuration.

Syntax

```
save storageArray dbmValidatorInfo file="filename" dbmDatabase="filename"
```

Parameters

| Parameter | Description |
|-----------|--|
| file | <p>The file path and the file name of the DBM Validator required for Customer and Technical Support. Enclose the file name in double quotation marks (" "). For example:</p> <pre>file="C:\Array Backups \DBMvalidator.xml"</pre> <p>This command does not automatically append a file extension to the saved file. You must specify a file extension when entering the file name.</p> |

| Parameter | Description |
|-------------|---|
| dbmDatabase | <p>The file path and the file name of the DBM database you want to use to restore a storage array. Enclose the file name in double quotation marks (" "). For example:</p> <pre>dbmDatabase="C:\Array Backups \DBMbackup_03302010.dbm"</pre> <p>This command does not automatically append a file extension to the saved file. You must specify a file extension when entering the file name.</p> |

Minimum Firmware Level

7.75

Save Storage Array Diagnostic Data

This command saves the storage array diagnostic data from either the controllers or the environmental services monitors (ESMs) to a file. You can review the file contents at a later time. You can also send the file to your Customer and Technical Support representative for further review.

After you have saved the diagnostic data, you can reset the NVSRAM registers that contain the diagnostic data so that the old data can be overwritten. Use the `reset storageArray diagnosticData` command to reset the diagnostic data registers.



ATTENTION Run this command only with the assistance of your Customer and Technical Support representative.

Syntax

```
save storageArray diagnosticData [(controller | tray)]
file="filename"
```

Parameters

| Parameter | Description |
|----------------|---|
| diagnosticData | This parameter allows you to download the diagnostic data from either the controllers or the ESMs. |
| file | <p>The file path and the file name to which you want to save the storage array diagnostic data. Enclose the file name in double quotation marks (" "). For example:</p> <pre>file="C:\Program Files\CLI\logs\sadiag.zip"</pre> <p>This command automatically saves the data to a compressed file; however, this command does not automatically append a file extension to the saved file. You must specify the <code>.zip</code> extension when entering the file name.</p> |

Notes

In versions of this command before 10.77, the user option was `esm` instead of `tray`. Starting in 10.77 `tray` replaces `esm`. The use of `esm` is still supported, but for best compatibility with future releases, replace `esm` with `tray`.

Minimum Firmware Level

6.16

7.77 `tray` replaces `esm`.

Save Storage Array Events

This command saves events from the Major Event Log to a file. You can save these events:

- **Critical events** – An error occurred on the storage array that needs to be addressed immediately. Loss of data access might occur if you do not immediately correct the error.
- **Warning events** – An error occurred on the storage array that results in degraded performance or reduced ability to recover from another error. Access to data has not been lost, but you must correct the error to prevent possible loss of data access if another error would occur.
- **Informational events** – An event occurred on the storage array that does not impact normal operations. The event is reporting a change in configuration or other information that might be useful in evaluating how well the storage array is performing.
- **Debug events** – An event occurred on the storage array that provides information that you can use to help determine the steps or states that led to an error. You can send a file with this information to your Customer and Technical Support representative to help determine the cause of an error.



NOTE Some storage arrays might not be able to support all four types of events.

Syntax

```
save storageArray (allEvents | criticalEvents |
warningEvents | infoEvents | debugEvents)
file="filename"
[count=numberOfEvents
forceSave=(TRUE | FALSE)]
```

Parameters

| Parameter | Description |
|-----------------------------|--|
| <code>allEvents</code> | The parameter to save all of the events to a file. |
| <code>criticalEvents</code> | The parameter to save only the critical events to a file. |
| <code>warningEvents</code> | The parameter to save only the warning events to a file. |
| <code>infoEvents</code> | The parameter to save only the informational events to a file. |
| <code>debugEvents</code> | The parameter to save only the debut events to a file. |

| Parameter | Description |
|-----------|--|
| file | The file path and the file name to which you want to save the events. Enclose the file name in double quotation marks (" "). For example: file="C:\Program Files\CLI\logs\events.txt" This command does not automatically append a file extension to the saved file. You must specify a file extension when entering the file name. |
| count | The number of events or critical events that you want to save to a file. If you do not enter a value for the count, all events or all critical events are saved to the file. If you enter a value for the count, only that number of events or critical events (starting with the last event entered) are saved to the file. Use integer values. |
| forceSave | The parameter to force saving the critical events to a file. To force saving the events, set this parameter to TRUE . The default value is FALSE . |

Notes

You have the option to save all events (**allEvents**) or only the critical events (**criticalEvents**).

Minimum Firmware Level

6.10

7.77 add these parameters:

- warningEvents
- infoEvents
- debugEvents
- forceSave

Save Storage Array Firmware Inventory

This command saves a report to a file of all of the firmware currently running on the storage array. The report lists the firmware for these components:

- Controllers
- Drives
- Drawers (if applicable)
- Environmental services monitors (ESMs)

You can use the information to help identify out-of-date firmware or firmware that does not match the other firmware in your storage array. You can also send the report to your Customer and Technical Support representative for further review.

Syntax

```
save storageArray firmwareInventory file="filename"
```

Parameter

| Parameter | Description |
|-----------|---|
| file | The file path and the file name to which you want to save the firmware inventory. Enclose the file name in double quotation marks (" "). For example: file="C:\Program Files\CLI\logs\fwinvent.txt" This command does not automatically append a file extension to the saved file. You must specify a file extension when entering the file name. |

Minimum Firmware Level

7.70

Save Storage Array InfiniBand Statistics

This command saves the InfiniBand performance statistics of the storage array to a file.

Syntax

```
save storageArray ibStats [raw | baseline]
file="filename"
```

Parameters

| Parameter | Description |
|-----------|--|
| raw | The statistics that are collected are all statistics from the controller start-of-day. Enclose the parameter in square brackets ([]). |
| baseline | The statistics that are collected are all statistics from the time the controllers were reset to zero using the reset storageArray ibStatsBaseline command. Enclose the parameter in square brackets ([]). |
| file | The file path and the file name to which you want to save the performance statistics. Enclose the file name in double quotation marks (" "). For example: file="C:\Program Files\CLI\sup\ibstat.txt" This command does not automatically append a file extension to the saved file. You must specify a file extension when entering the file name. |

Notes

If you have not reset the InfiniBand baseline statistics since the controller start-of-day, the time at the start-of-day is the default baseline time.

Minimum Firmware Level

7.32

Save Storage Array iSCSI Statistics

This command saves the iSCSI performance of the storage array to a file.

Syntax

```
save storageArray iscsiStatistics [raw | baseline] file="filename"
```

Parameters

| Parameter | Description |
|-----------|---|
| raw | The statistics collected are all statistics from the controller start-of-day. Enclose the parameter in square brackets ([]). |
| baseline | The statistics that are collected are all statistics from the time the controllers were reset to zero using the reset storageArray ibStatsBaseline command. Enclose the parameter in square brackets ([]). |
| file | The file path and the file name to which you want to save the performance statistics. Enclose the file name in double quotation marks (" "). For example: file="C:\Program Files\CLI\logs\iscsistat.csv" This command does not automatically append a file extension to the saved file. You can use any file name but you must use the .csv extension. |

Notes

If you have not reset the iSCSI baseline statistics since the controller start-of-day, the time at the start-of-day is the default baseline time.

Minimum Firmware Level

7.10

Save Storage Array Performance Statistics

This command saves the performance statistics to a file. Before you use this command, run the **set session performanceMonitorInterval** command and the **set session performanceMonitorIterations** command to specify how often statistics are collected.

Syntax

```
save storageArray performanceStats file="filename"
```

Parameter

| Parameter | Description |
|-----------|--|
| file | The file path and the file name to which you want to save the performance statistics. Enclose the file name in double quotation marks (" "). For example: file="C:\Program Files\CLI\logs\sastat.csv" |

| Parameter | Description |
|-----------|---|
| | This command does not automatically append a file extension to the saved file. You can use any file name, but you must use the <code>.csv</code> extension. |

Minimum Firmware Level

6.10

Save Storage Array RLS Counts

This command saves the read link status (RLS) counters to a file.

Syntax

```
save storageArray RLSCounts file="filename"
```

Parameter

| Parameter | Description |
|-----------|--|
| file | The file path and the file name to which you want to save the RLS counters. Enclose the file name in double quotation marks (" "). For example: file="C:\Program Files\CLI\logs\rlsCnt.csv" The default name of the file that contains the RLS counts is readLinkStatus.csv . You can use any file name, but you must use the <code>.csv</code> extension. |

Notes

To more effectively save RLS counters to a file, perform these steps:

1. Run the `reset storageArray RLSBaseline` command to set all of the RLS counters to 0.
2. Run the storage array for a predetermined amount of time (for instance, two hours).
3. Run the `save storageArray RLSCounts file="filename"` command.

Minimum Firmware Level

6.10

Save Storage Array SAS PHY Counts

This command saves the SAS physical layer (SAS PHY) counters to a file. To reset the SAS PHY counters, run the `reset storageArray SASPHYBaseline` command.

Syntax

```
save storageArray SASPHYCounts file="filename"
```

Parameter

| Parameter | Description |
|-----------|---|
| file | The file path and the file name to which you want to save the SAS PHY counters. Enclose the file path and the file name in double quotation marks (" "). For example: file="C:\Program Files\CLI\logs\sasphy.csv" This command does not automatically append a file extension to the saved file. You can use any file name but you must use the .csv extension. |

Minimum Firmware Level

6.10

Save Storage Array SOC Counts

This command saves the SOC error statistics to a file. This command is valid only for Fibre Channel devices in an arbitrated loop topology.

Syntax

```
save storageArray SOCCounts file="filename"
```

Parameter

| Parameter | Description |
|-----------|---|
| file | The file path and the file name to which you want to save the SOC error statistics. Enclose the file name in double quotation marks (" "). For example: file="C:\Program Files\CLI\logs\socstat.csv" The default name of the file that contains the SOC error statistics is socStatistics.csv. You can use any file name but you must use the .csv extension. |

Notes

To more effectively save SOC error statistics to a file, perform these steps:

1. Run the `reset storageArray SOCBaseline` command to set all of the SOC counters to 0.
2. Run the storage array for a predetermined amount of time (for example, two hours).
3. Run the `save storageArray SOCCounts file="filename"` command.

Minimum Firmware Level

6.16

Save Storage Array State Capture

This command saves the state capture of a storage array to a file.

Syntax

```
save storageArray stateCapture file="filename"
```

Parameter

| Parameter | Description |
|-----------|---|
| file | The file path and the file name to which you want to save the state capture. Enclose the file name in double quotation marks (" "). For example: file="C:\Program Files\CLI\logs\state.zip" This command does not automatically append a file extension to the saved file. You must specify a file extension when entering the file name. |

Minimum Firmware Level

6.10

Save Storage Array Support Data

This command saves the support-related information of the storage array to a file. Support-related information includes these items:

- The storage array profile
- The Major Event Log information
- The read link status (RLS) data
- The NVSRAM data
- Current problems and associated recovery information
- The performance statistics for the entire storage array
- The persistent registration information and the persistent reservation information
- Detailed information about the current status of the storage array
- The diagnostic data for the drive
- A recovery profile for the storage array
- The unreadable sectors that are detected on the storage array
- The state capture data
- An inventory of the versions of the firmware running on the controllers, the drives, the drawers, and the environmental services monitors (ESMs)

Syntax

```
save storageArray supportData file="filename"  
[force=(TRUE | FALSE)]
```

Parameter

| Parameter | Description |
|-----------|---|
| file | The file path and the file name to which you want to save the support-related data for the storage array. Enclose the file path and the file name in double quotation marks (" "). For example: file="C:\Program Files\CLI\logs\supdat.zip" This command does not automatically append a file extension to the saved file. You must specify a file extension when entering the file name. |
| force | This parameter forces the collection of support data if there are any failures in securing a lock on controller operations. To force the collection of support data, set this parameter to TRUE . The default value is FALSE . |

Minimum Firmware Level

6.10

7.80 adds the `force` parameter.**Save Tray Log**

This command saves the log sense data to a file. Log sense data is maintained by the environmental cards for each tray. Not all of the environmental cards contain log sense data.

Syntax

```
save allTrays logFile="filename"
```

Parameter

| Parameter | Description |
|-----------|---|
| logFile | The file path and the file name to which you want to save the log sense data. Enclose the file name in double quotation marks (" "). For example: file="C:\Program Files\CLI\logs\traylogdat.txt" This command does not automatically append a file extension to the saved file. You must specify a file extension when entering the file name. |

Minimum Firmware Level

6.50

Set Controller

This command defines the attributes for the controllers.

Syntax

```

set controller [(a | b)]
availability=(online | offline | serviceMode) |
ethernetPort [(1 | 2)] ethernetPortOptions |
globalNVSramByte [nvsramOffset]=(nvsramByteSetting | nvsramBitSetting) |
hostNVSramByte [hostType, nvsramOffset]=(nvsramByteSetting | nvsramBitSetting) |
IPv4GatewayIP=ipAddress |
IPv6RouterAddress=ipv6Address |
iscsiHostPort [(1 | 2 | 3 | 4)] iscsiHostPortOptions
rloginEnabled=(TRUE | FALSE) |
serviceAllowedIndicator=(on | off)

```

Parameters

| Parameter | Description |
|-------------------|---|
| controller | The controller for which you want to define properties. Valid identifiers for the controller are a or b , where a is the controller in slot A, and b is the controller in slot B. Enclose the identifier for the controller in square brackets ([]). If you do not specify a controller, the firmware for the controller returns a syntax error. |
| availability | The mode for the controller, which you can set to online , offline , or serviceMode (service). |
| ethernetPort | The attributes (options) for the management Ethernet ports. The entries to support this parameter are listed in the Syntax Element Statement Data table that follows. Many settings are possible, including setting the IP address, the gateway address, and the subnet mask address. |
| globalNVSramByte | A portion of the controller NVSRAM. Specify the region to be modified using the starting byte offset within the region and the byte value or bit value of the new data to be stored into the NVSRAM. |
| hostNVSramByte | The NVSRAM for the host-specific region. The setting specifies the host index for the specific host, the starting offset within the region, the number of bytes, and the the byte value or bit value of the new data to be stored into the NVSRAM. |
| IPv4GatewayIP | The IP address of the node that provides the interface to the network. The address format for the IPv4 gateway is (0-255).(0-255).(0-255).(0-255) |
| IPv6RouterAddress | The IP address of IPv6 router that connects two or more logical subnets. The address format for the IPv6 router is (0-FFFF):(0-FFFF):(0-FFFF):(0-FFFF):(0-FFFF):(0-FFFF):(0-FFFF):(0-FFFF) . |

| Parameter | Description |
|-------------------------|--|
| iscsiHostPort | The values that support this parameter are listed in the Syntax Element Statement Data table that follows. Many settings are possible, including setting the IP address, the gateway address, the subnet mask address, the IPv4 priority, and the IPv6 priority. |
| rloginEnabled | The setting for whether the remote login feature is turned on or turned off. To turn on the remote login feature, set this parameter to TRUE . To turn off the remote login feature, set this parameter to FALSE . |
| serviceAllowedIndicator | The setting for whether the Service Action Allowed indicator light is turned on or turned off. To turn on the Service Action Allowed indicator light, set this parameter to on . To turn off the Service Action Allowed indicator light, set this parameter to off . |

Syntax Element Statement Data

| Options for the ethernetPort Parameter |
|---|
| enableIPv4=(TRUE FALSE) |
| enableIPv6=(TRUE FALSE) |
| IPv6LocalAddress=(0-FFFF):(0-FFFF):(0-FFFF):(0-FFFF): (0-FFFF):(0-FFFF):(0-FFFF):(0-FFFF) |
| IPv6RoutableAddress=(0-FFFF):(0-FFFF):(0-FFFF):(0-FFFF): (0-FFFF):(0-FFFF):(0-FFFF):(0-FFFF) |
| IPv4Address=(0-255).(0-255).(0-255).(0-255) |
| IPv4ConfigurationMethod=[(static dhcp)] |
| IPv4SubnetMask=(0-255).(0-255).(0-255).(0-255) |
| duplexMode=(TRUE FALSE) |
| portSpeed=(autoNegotiate 10 100 1000) |

| Options for the iscsiHostPort Parameter |
|---|
| IPv4Address=(0-255).(0-255).(0-255).(0-255) |
| IPv6LocalAddress=(0-FFFF):(0-FFFF):(0-FFFF):(0-FFFF): (0-FFFF):(0-FFFF):(0-FFFF):(0-FFFF) |
| IPv6RoutableAddress=(0-FFFF):(0-FFFF):(0-FFFF):(0-FFFF): (0-FFFF):(0-FFFF):(0-FFFF):(0-FFFF) |

Options for the `iscsiHostPort` Parameter

IPv6RouterAddress=(0-FFFF):(0-FFFF):(0-FFFF):(0-FFFF):
(0-FFFF):(0-FFFF):(0-FFFF):(0-FFFF) |

enableIPv4=(TRUE | FALSE) |

enableIPv6=(TRUE | FALSE) |

enableIPv4Vlan=(TRUE | FALSE) |

enableIPv6Vlan=(TRUE | FALSE) |

enableIPv4Priority=(TRUE | FALSE) |

enableIPv6Priority=(TRUE | FALSE) |

IPv4ConfigurationMethod=(static | dhcp) |

IPv6ConfigurationMethod=(static | auto) |

IPv4GatewayIP=(TRUE | FALSE) |

IPv6HopLimit=[0-255] |

IPv6NdDetectDuplicateAddress=[0-256] |

IPv6NdReachableTime=[0-65535] |

IPv6NdRetransmitTime=[0-65535] |

IPv6NdTimeOut=[0-65535] |

IPv4Priority=[0-7] |

IPv6Priority=[0-7] |

IPv4SubnetMask=(0-255).(0-255).(0-255).(0-255) |

IPv4VlanId=[1-4094] |

IPv6VlanId=[1-4094] |

maxFramePayload=[*frameSize*] |

tcpListeningPort=[3260, 49152-65536] |

portSpeed=(autoNegotiate | 1 | 10)

Notes



NOTE Before firmware version 7.75, the `set controller` command supported an `NVSRAMByte` parameter. The `NVSRAMByte` parameter is deprecated and must be replaced with either the `hostNVSRAMByte` parameter or the `globalNVSRAMByte` parameter.

When you use this command, you can specify one or more of the parameters. You do not need to use all of the parameters.

Setting the `availability` parameter to `serviceMode` causes the alternate controller to take ownership of all of the volumes. The specified controller no longer has any volumes and refuses to take ownership of any more volumes. Service mode is persistent across reset cycles and power cycles until the `availability` parameter is set to `online`.

Use the `show controller NVSRAM` command to show the NVSRAM information. Before making any changes to the NVSRAM, contact your Customer and Technical Support representative to learn what regions of the NVSRAM you can modify.

When the `duplexMode` option is set to `TRUE`, the selected Ethernet port is set to full duplex. The default value is half duplex (the `duplexMode` parameter is set to `FALSE`).

To make sure that the IPv4 settings or the IPv6 settings are applied, you must set these `iscsiHostPort` options:

- `enableIPV4=TRUE`
- `enableIPV6=TRUE`

The IPv6 address space is 128 bits. It is represented by eight 16-bit hexadecimal blocks separated by colons.

The `maxFramePayload` option is shared between IPv4 and IPv6. The payload portion of a standard Ethernet frame is set to 1500, and a jumbo Ethernet frame is set to 9000. When using jumbo frames, all of the devices that are in the network path should be capable of handling the larger frame size.

The `portSpeed` option is expressed as megabits per second (Mb/s).

Values for the `portSpeed` option of the `iscsiHostPort` parameter are in megabits per second (Mb/s).

The following values are the default values for the `iscsiHostOptions`:

- The `IPv6HopLimit` option is 64.
- The `IPv6NdReachableTime` option is 30000 milliseconds.
- The `IPv6NdRetransmitTime` option is 1000 milliseconds.
- The `IPv6NdTimeOut` option is 30000 milliseconds.
- The `tcpListeningPort` option is 3260.

Minimum Firmware Level

7.15 removed the `bootp` parameter, and added the new Ethernet port options and the new iSCSI host port options.

7.50 moved the `IPV4Gateway` parameter and the `IPV6RouterAddress` parameter from the iSCSI host port options to the command.

7.60 adds the `portSpeed` option of the `iscsiHostPort` parameter.

7.75 deprecates the `NVSRAMByte` parameter.

Set Controller Service Action Allowed Indicator

This command turns on or turns off the Service Action Allowed indicator light on a controller in a controller tray or a controller-drive tray. If the storage array does not support the Service Action Allowed indicator light feature, this command returns an error. If the storage array supports the command but is unable to turn on or turn off the indicator light, this command returns an error. (To turn on or turn off the Service Action Allowed indicator light on the power-fan canister or the interconnect-battery canister, use the `set tray serviceAllowedIndicator` command.)

Syntax

```
set controller=[(a | b)]
serviceAllowedIndicator=(on | off)
```

Parameters

| Parameter | Description |
|--------------------------------------|--|
| <code>controller</code> | The controller that has the Service Action Allowed indicator light that you want to turn on or turn off. Valid controller identifiers are <code>a</code> or <code>b</code> , where <code>a</code> is the controller in slot A, and <code>b</code> is the controller in slot B. Enclose the controller identifier in square brackets ([]). If you do not specify a controller, the controller firmware returns a syntax error. |
| <code>serviceAllowedIndicator</code> | The setting to turn on or turn off the Service Action Allowed indicator light. To turn on the Service Action Allowed indicator light, set this parameter to <code>on</code> . To turn off the Service Action Allowed indicator light, set this parameter to <code>off</code> . |

Notes

This command was originally defined for use with the CE6998 controller tray. This command is not supported by controller trays that were shipped before the introduction of the CE6998 controller tray. The 3992 and 3994 controllers also support this command.

Minimum Firmware Level

6.14

Set Drawer Service Action Allowed Indicator

This command turns on or turns off the Service Action Allowed indicator light on a drawer that holds drives. Drawers are used in high-capacity drive trays. The drawers slide out of the drive tray to provide access to the drives. Use this command only for drive trays that use drawers. If the storage array does not support the Service Action Allowed indicator light feature, this command returns an error. If the storage array supports the command but is unable to turn on or turn off the indicator light, this command returns an error.

Syntax

```
set tray [trayID] drawer [drawerID]
serviceAllowedIndicator=(on | off | forceOnWarning)
```

Parameters

| Parameter | Description |
|-------------------------|--|
| tray | The tray where the drawer resides. Tray ID values are 0 to 99. Enclose the tray ID value in square brackets ([]). If you do not enter a tray ID value, the tray ID of the controller tray is the default value. |
| drawer | The location of the drawer for which you want to turn on or turn off the Service Action Allowed Indicator light. Drawer ID values are 1 to 5. Enclose the drawer ID value in square brackets ([]). |
| serviceAllowedIndicator | The setting to turn on or turn off the Service Action Allowed indicator light. To turn on the Service Action Allowed indicator light, set this parameter to on . To turn off the Service Action Allowed indicator light, set this parameter to off . For information about using <code>forceOnWarning</code> , see the Notes. |

Notes

Before you can enter this command, the drive tray must meet these conditions:

- The drive tray cannot be over temperature.
- The fans must have a status of Optimal.
- All drive tray components must be in place.
- The volumes in the drive drawer cannot be in a Degraded state. If you remove drives from the drive drawer and a volume is already in a Degraded state, the volume can fail.



ATTENTION Do not issue this command if you cannot meet any of these conditions.

All volumes with drives in the affected drive drawer are checked to make sure that the volumes have drawer loss protection before the command is sent. If the volumes have drawer loss protection, the Set Service Action Allowed command proceeds without stopping I/O activity to the volume.

If any volumes in the affected drawer do not have drawer loss protection, you must stop I/O activity to those volumes. A warning appears, which indicates that this command should not be completed.

If you are preparing a component for removal and want to override the warning that the volumes do not have drawer loss protection, enter this parameter:

```
serviceAllowedIndicator=forceOnWarning
```

`forceOnWarning` sends the request to prepare to remove a component to the controller firmware, and forces the `set drawer serviceAllowedIndicator` command to proceed.

To turn on or turn off the Service Action Allowed indicator light for the entire high-capacity drive tray, use the `set tray serviceAllowedIndicator` command.

Minimum Firmware Level

7.60

Set Drive Channel Status

This command defines how the drive channel performs.

Syntax

```
set driveChannel [(1 | 2 | 3 | 4 | 5 | 6 | 7 | 8)]
status=(optimal | degraded)
```

Parameters

| Parameter | Description |
|---------------------------|---|
| <code>driveChannel</code> | The identifier number of the drive channel for which you want to set the status. Valid drive channel values are 1, 2, 3, 4, 5, 6, 7, or 8. Enclose the drive channel number in square brackets ([]). |
| <code>status</code> | The condition of the drive channel. You can set the drive channel status to optimal or degraded . |

Notes

Use the **optimal** option to move a degraded drive channel back to the Optimal state. Use the **degraded** option when the drive channel is experiencing problems, and the storage array requires additional time for data transfers.

Minimum Firmware Level

6.10

7.15 adds the update to the drive channel identifier.

Set Drive Hot Spare

This command assigns or unassigns one or more drives as a hot spare.

Syntax

```
set (drive [trayID,drawerID,slotID] |
drives [trayID1,drawerID1,slotID1 ... trayIDn,drawerIDn,slotIDn])
hotSpare=(TRUE | FALSE)
```

Parameters

| Parameter | Description |
|-----------------|---|
| drive or drives | The location of the drive that you want to use for a hot spare. For high-capacity drive trays, specify the tray ID value, the drawer ID value, and the slot ID value for the drive. For low-capacity drive trays, specify the tray ID value and the slot ID value for the drive. Tray ID values are 0 to 99. Drawer ID values are 1 to 5. Slot ID values are 1 to 32. Enclose the tray ID value, the drawer ID value, and the slot ID value in square brackets ([]). |
| hotSpare | The setting to assign the drive as the hot spare. To assign the drive as the hot spare, set this parameter to TRUE . To remove a hot spare assignment from a drive, set this parameter to FALSE . |

Notes

The `drive` parameter supports both high-capacity drive trays and low-capacity drive trays. A high-capacity drive tray has drawers that hold the drives. The drawers slide out of the drive tray to provide access to the drives. A low-capacity drive tray does not have drawers. For a high-capacity drive tray, you must specify the identifier (ID) of the drive tray, the ID of the drawer, and the ID of the slot in which a drive resides. For a low-capacity drive tray, you need only specify the ID of the drive tray and the ID of the slot in which a drive resides. For a low-capacity drive tray, an alternative method for identifying a location for a drive is to specify the ID of the drive tray, set the ID of the drawer to 0, and specify the ID of the slot in which a drive resides.

Minimum Firmware Level

6.10

7.60 adds the `drawerID` user input.

Set Drive Service Action Allowed Indicator

This command turns on or turns off the Service Action Allowed indicator light on a drive in drive trays that support the Service Action Allowed indicator light feature. If the storage array does not support the Service Action Allowed indicator light feature, this command returns an error. If the storage array supports the command but is unable to turn on or turn off the indicator light, this command returns an error.

Syntax

```
set (drive [trayID,drawerID,slotID] |
drives [trayID1,drawerID1,slotID1 ... trayIDn,drawerIDn,slotIDn])
serviceAllowedIndicator=(on | off)
```

Parameters

| Parameter | Description |
|-----------------|--|
| drive or drives | The location of the drive that you want to turn on or turn off the service action allowed indicator. For high-capacity drive trays, specify the tray ID value, |

| Parameter | Description |
|-------------------------|---|
| | the drawer ID value, and the slot ID value for the drive. For low-capacity drive trays, specify the tray ID value and the slot ID value for the drive. Tray ID values are 0 to 99. Drawer ID values are 1 to 5. Slot ID values are 1 to 32. Enclose the tray ID value, the drawer ID value, and the slot ID value in square brackets ([]). |
| serviceAllowedIndicator | The setting to turn on or turn off the Service Action Allowed indicator light. To turn on the Service Action Allowed indicator light, set this parameter to <code>on</code> . To turn off the Service Action Allowed indicator light, set this parameter to <code>off</code> . |

Notes

The `drive` parameter supports both high-capacity drive trays and low-capacity drive trays. A high-capacity drive tray has drawers that hold the drives. The drawers slide out of the drive tray to provide access to the drives. A low-capacity drive tray does not have drawers. For a high-capacity drive tray, you must specify the identifier (ID) of the drive tray, the ID of the drawer, and the ID of the slot in which a drive resides. For a low-capacity drive tray, you need only specify the ID of the drive tray and the ID of the slot in which a drive resides. For a low-capacity drive tray, an alternative method for identifying a location for a drive is to specify the ID of the drive tray, set the ID of the drawer to 0, and specify the ID of the slot in which a drive resides.

Minimum Firmware Level

6.16

7.60 adds the `drawerID` user input.

Set Drive State

This command sets a drive to the Failed state. (To return a drive to the Optimal state, use the `revive drive` command.)

Syntax

```
set drive [trayID,drawerID,slotID]
operationalState=failed
```

Parameter

| Parameter | Description |
|-----------|---|
| drive | The location of the drive that you want to set to the Failed state. For high-capacity drive trays, specify the tray ID value, the drawer ID value, and the slot ID value for the drive. For low-capacity drive trays, specify the tray ID value and the slot ID value for the drive. Tray ID values are 0 to 99. Drawer ID values are 1 to 5. Slot ID values are 1 to 32. Enclose the tray ID value, the drawer ID value, and the slot ID value in square brackets ([]). |

Notes

The `drive` parameter supports both high-capacity drive trays and low-capacity drive trays. A high-capacity drive tray has drawers that hold the drives. The drawers slide out of the drive tray to provide access to the drives. A low-capacity drive tray does not have drawers. For a high-capacity drive tray, you must specify the identifier (ID) of the drive tray, the ID of the drawer, and the ID of the slot in which a drive resides. For a low-capacity drive tray, you need only specify the ID of the drive tray and the ID of the slot in which a drive resides. For a low-capacity drive tray, an alternative method for identifying a location for a drive is to specify the ID of the drive tray, set the ID of the drawer to 0, and specify the ID of the slot in which a drive resides.

Minimum Firmware Level

5.20

7.60 adds the `drawerID` user input.

Set Foreign Drive to Native

A drive is considered to be native when it is a part of a volume group in a storage array. A drive is considered to be foreign when it does not belong to a volume group in a storage array or when it fails to be imported with the drives of a volume group that are transferred to a new storage array. The latter failure creates an incomplete volume group on the new storage array.

Run this command to add the missing (foreign) drives back into their original volume group and to make them part of the volume group in the new storage array.

Use this operation for emergency recovery only: when one or more drives need to be changed from a foreign drive status and returned to a native status within their original volume group.



ATTENTION Possible data corruption or data loss – Using this command for reasons other than what is stated previously might result in data loss without notification.

Syntax

```
set (drive [trayID,drawerID,slotID] |
    drives [trayID1,drawerID1,slotID1 ... trayIDn,drawerIDn,slotIDn] |
    allDrives) nativeState
```

Parameters

| Parameter | Description |
|---|--|
| <code>drive</code> or <code>drives</code> | The location of the foreign drive that you want to add to the volume group in a storage array. For high-capacity drive trays, specify the tray ID value, the drawer ID value, and the slot ID value for the drive. For low-capacity drive trays, specify the tray ID value and the slot ID value for the drive. Tray ID values are 0 to 99. Drawer ID values are 1 to 5. Slot ID values are 1 to 32. Enclose the tray ID value, the drawer ID value, and the slot ID value in square brackets ([]). |
| <code>allDrives</code> | The setting to select all of the drives. |

Notes

The `drive` parameter supports both high-capacity drive trays and low-capacity drive trays. A high-capacity drive tray has drawers that hold the drives. The drawers slide out of the drive tray to provide access to the drives. A low-capacity drive tray does not have drawers. For a high-capacity drive tray, you must specify the identifier (ID) of the drive tray, the ID of the drawer, and the ID of the slot in which a drive resides. For a low-capacity drive tray, you need only specify the ID of the drive tray and the ID of the slot in which a drive resides. For a low-capacity drive tray, an alternative method for identifying a location for a drive is to specify the ID of the drive tray, set the ID of the drawer to 0, and specify the ID of the slot in which a drive resides.

Minimum Firmware Level

7.10

7.60 adds the `drawerID` user input.

Set Host

This command assigns a host to a host group or moves a host to a different host group. You can also create a new host group and assign the host to the new host group with this command. The actions performed by this command depend on whether the host has individual mappings or does not have individual mappings.

Syntax

```
set host [hostName]
hostGroup=( "hostGroupName" | none | defaultGroup )
userLabel="newHostName"
hostType=( hostTypeIndexLabel | hostTypeIndexNumber )
```

Parameters

| Parameter | Description |
|------------------------|--|
| <code>host</code> | The name of the host that you want to assign to a host group. Enclose the host name in square brackets ([]). If the host name has special characters, you also must enclose the host name in double quotation marks (" "). |
| <code>hostGroup</code> | The name of the host group to which you want to assign the host. (The following table defines how the command runs if the host does or does not have individual mappings.) Enclose the host group name in double quotation marks (" "). The <code>defaultGroup</code> option is the host group that contains the host to which the volume is mapped. |
| <code>userLabel</code> | The new host name. Enclose the host name in double quotation marks (" "). |
| <code>hostType</code> | The index label or number of the host type for the host port. Use the <code>show storageArray hostTypeTable</code> command to generate a list of available host type identifiers. If the host type has special characters, enclose the host type in double quotation marks (" "). |

| Host Group Parameter | Host Has Individual Mappings | Host Does Not Have Individual Mappings |
|----------------------|--|--|
| <i>hostGroupName</i> | The host is removed from the present host group and is placed under the new host group defined by <i>hostGroupName</i> . | The host is removed from the present host group and is placed under the new host group defined by <i>hostGroupName</i> . |
| none | The host is removed from the host group as an independent partition and is placed under the root node. | The host is removed from the present host group and is placed under the default group. |
| defaultGroup | The command fails. | The host is removed from the present host group and is placed under the default group. |

Notes

When you use this command, you can specify one or more of the optional parameters.

For the names, you can use any combination of alphanumeric characters, hyphens, and underscores. Names can have a maximum of 30 characters.

Minimum Firmware Level

6.10

Set Host Channel

This command defines the loop ID for the host channel.

Syntax

```
set hostChannel [hostChannelNumber]
preferredID=portID
```

Parameters

| Parameter | Description |
|-------------|--|
| hostChannel | The identifier number of the host channel for which you want to set the loop ID. Enclose the host channel identifier number in square brackets ([]). Use a host channel value that is appropriate for your particular controller model. A controller tray might support one host channel or as many as eight host channels. Valid host channel values are a1, a2, a3, a4, a5, a6, a7, a8, b1, b2, b3, b4, b5, b6, b7, or b8 . |
| preferredID | The port identifier for the specified host channel. Port ID values are 0 to 127. |

Minimum Firmware Level

6.10

6.14 adds an update to the host channel identifier.

7.15 adds an update to the host channel identifier.

Set Host Group

This command renames a host group.

Syntax

```
set hostGroup [hostGroupName]  
userLabel="newHostGroupName"
```

Parameters

| Parameter | Description |
|-----------|---|
| hostGroup | The name of the host group that you want to rename. Enclose the host group name in square brackets ([]). If the host group name has special characters, you also must enclose the host group name in double quotation marks (" "). |
| userLabel | The new name for the host group. Enclose the new host group name in double quotation marks (" "). |

Notes

You can use any combination of alphanumeric characters, hyphens, and underscores for the names. Names can have a maximum of 30 characters.

Minimum Firmware Level

6.10

Set Host Port

This command changes the host type for a host port. You can also change a host port label with this command.

Syntax

```
set hostPort [portLabel] host="hostName" userLabel="newPortLabel"
```

Parameters

| Parameter | Description |
|-----------|--|
| hostPort | The name of the host port for which you want to change the host type, or for which you want to create a new name. Enclose the host port name in square brackets ([]). If the host port label has special characters, enclose the host port label in double quotation marks (" "). |
| host | The name of the host to which the host port is connected. Enclose the host name in double quotation marks (" "). |
| userLabel | The new name that you want to give to the host port. Enclose the new name of the host port in double quotation marks (" "). |

Notes

When you use this command, you can specify one or more of the optional parameters.

You can use any combination of alphanumeric characters, hyphens, and underscores for the names. Names can have a maximum of 30 characters.

Minimum Firmware Level

6.10

Set iSCSI Initiator

This command sets the attributes for an iSCSI initiator.

Syntax

```
set iscsiInitiator (["iscsiID"] |
userLabel="newName" |
host="newHostName" |
chapSecret="newSecurityKey")
```

Parameters

| Parameter | Description |
|----------------|---|
| iscsiInitiator | The name of the iSCSI initiator for which you want to set attributes. Enclose the iSCSI initiator name in double quotation marks (" ") and square brackets ([]). |
| userLabel | The new name that you want to use for the iSCSI initiator. Enclose the new name in double quotation marks (" "). |
| host | The name of the new host to which the host port is connected. Enclose the host name in double quotation marks (" "). |

| Parameter | Description |
|------------|--|
| chapSecret | The security key that you want to use to authenticate a peer connection. Enclose the security key in double quotation marks (" "). |

Notes

You can use any combination of alphanumeric characters, hyphens, and underscores for the names. Names can have a maximum of 30 characters.

Challenge Handshake Authentication Protocol (CHAP) is a protocol that authenticates the peer of a connection. CHAP is based upon the peers sharing a *secret*. A secret is a security key that is similar to a password.

Use the `chapSecret` parameter to set up the security keys for initiators that require a mutual authentication. The CHAP secret must be between 12 characters and 57 characters. This table lists the valid characters.

| | | | | | | | | | | | |
|-------|---|---|---|----|---|---|---|---|---|---|---|
| Space | ! | " | # | \$ | % | & | ' | (|) | * | + |
| , | - | . | / | 0 | 1 | 2 | 3 | 4 | 5 | 6 | 7 |
| 8 | 9 | : | ; | < | = | > | ? | @ | A | B | C |
| D | E | F | G | H | I | J | K | L | M | N | O |
| P | Q | R | S | T | U | V | W | X | Y | Z | [|
| \ |] | ^ | _ | ' | a | b | c | d | e | f | g |
| h | i | j | k | l | m | n | o | p | q | r | s |
| t | u | v | w | x | y | z | { | | } | ~ | |

Minimum Firmware Level

7.10

Set iSCSI Target Properties

This command defines properties for an iSCSI target.

Syntax

```
set iscsiTarget ["userLabel"]
authenticationMethod=(none | chap) |
chapSecret=securityKey |
targetAlias="userLabel"
```

Parameters

| Parameter | Description |
|-----------------------------------|--|
| <code>iscsiTarget</code> | The iSCSI target for which you want to set properties. Enclose the <code>userLabel</code> in double quotation marks (" "). You must also enclose the <code>userLabel</code> in either square brackets ([]) or angle brackets (< >). |
| <code>authenticationMethod</code> | The means of authenticating your iSCSI session. |
| <code>chapSecret</code> | The security key that you want to use to authenticate a peer connection. |
| <code>targetAlias</code> | The new name that you want to use for the target. Enclose the name in double quotation marks (" "). |

Notes

Challenge Handshake Authentication Protocol (CHAP) is a protocol that authenticates the peer of a connection. CHAP is based upon the peers sharing a *secret*. A secret is a security key that is similar to a password.

Use the `chapSecret` parameter to set up the security keys for initiators that require a mutual authentication. The CHAP secret must be between 12 characters and 57 characters. This table lists the valid characters.

| | | | | | | | | | | | |
|-------|---|---|---|----|---|---|---|---|---|---|---|
| Space | ! | " | # | \$ | % | & | ' | (|) | * | + |
| , | - | . | / | 0 | 1 | 2 | 3 | 4 | 5 | 6 | 7 |
| 8 | 9 | : | ; | < | = | > | ? | @ | A | B | C |
| D | E | F | G | H | I | J | K | L | M | N | O |
| P | Q | R | S | T | U | V | W | X | Y | Z | [|
| \ |] | ^ | _ | ' | a | b | c | d | e | f | g |
| h | i | j | k | l | m | n | o | p | q | r | s |
| t | u | v | w | x | y | z | { | | } | ~ | |

Minimum Firmware Level

7.10

Set Remote Mirror

This command defines the properties for a remote-mirrored pair.

Syntax

```
set remoteMirror (localVolume [volumeName] |
localVolumes [volumeName1 ... volumeNameN])
role=(primary | secondary)
```



```
[force=(TRUE | FALSE)]
syncPriority=(highest | high | medium | low | lowest)
autoResync=(enabled | disabled)
writeOrder=(preserved | notPreserved)
writeMode=(synchronous | asynchronous)
```

Parameters

| Parameter | Description |
|-----------------------------|--|
| localVolume or localVolumes | The name of the primary volume for which you want to define properties. You can enter more than one primary volume name. Enclose the primary volume name in square brackets ([]). If the primary volume name has special characters, you also must enclose the primary volume name in double quotation marks (" "). |
| role | The setting for the volume to act as the primary volume or the secondary volume. To define the volume as the primary volume, set this parameter to primary . To define the volume as the secondary volume, set this parameter to secondary . This parameter applies only when the volume is part of a mirror relationship. |
| force | The role reversal is forced if the communications link between the storage arrays is down and promotion or demotion on the local side results in a dual-primary condition or a dual-secondary condition. To force a role reversal, set this parameter to TRUE . The default value is FALSE . |
| syncPriority | The priority that full synchronization has relative to host I/O activity. Valid values are highest , high , medium , low , or lowest . |
| autoResync | The settings for automatic resynchronization between the primary volumes and the secondary volumes of a remote-mirrored pair. This parameter has these values: <ul style="list-style-type: none"> ▪ enabled – Automatic resynchronization is turned on. You do not need to do anything further to resynchronize the primary volume and the secondary volume. ▪ disabled – Automatic resynchronization is turned off. To resynchronize the primary volumes and the secondary volume, you must run the resume remoteMirror command. |
| writeOrder | This parameter defines write order for data transmission between the primary volume and the secondary volume. Valid values are preserved or notPreserved . |
| writeMode | This parameter defines how the primary volume writes to the secondary volume. Valid values are synchronous or asynchronous . |

Notes

When you use this command, you can specify one or more of the optional parameters.

Synchronization priority defines the amount of system resources that are used to synchronize the data between the primary volumes and the secondary volumes of a mirror relationship. If you select the highest priority level, the data synchronization uses the most system resources to perform the full synchronization, which decreases the performance for host data transfers.

The `writeOrder` parameter applies only to asynchronous mirrors and makes them become part of a consistency group. Setting the `writeOrder` parameter to **preserved** causes the remote-mirrored pair to transmit data from the primary volume to the secondary volume in the same order as the host writes to the primary volume. In the event of a transmission link failure, the data is buffered until a full synchronization can occur. This action can require additional system overhead to maintain the buffered data, which slows operations. Setting the `writeOrder` parameter to **notPreserved** frees the system from having to maintain data in a buffer, but it requires forcing a full synchronization to make sure that the secondary volume has the same data as the primary volume.

Minimum Firmware Level

6.10

Set Session

This command defines how you want the current script engine session to run.

Syntax

```
set session errorAction=(stop | continue)
password="storageArrayPassword"
performanceMonitorInterval=intervalValue
performanceMonitorIterations=iterationValue
```

Parameters

| Parameter | Description |
|---|--|
| <code>errorAction</code> | How the session responds if an error is encountered during processing. You can choose to stop the session if an error is encountered, or you can continue the session after encountering an error. The default value is stop . (This parameter defines the action for execution errors, not syntax errors. Some error conditions might override the continue value.) |
| <code>password</code> | The password for the storage array. Enclose the password in double quotation marks (" "). |
| <code>performanceMonitorInterval</code> | The frequency of gathering performance data. Enter an integer value for the polling interval, in seconds, for which you want |

| Parameter | Description |
|------------------------------|--|
| | to capture data. The range of values is 3 to 3600 seconds. The default value is 5 seconds. |
| performanceMonitorIterations | The number of samples to capture. Enter an integer value. The range of values for samples captured is 1 to 3600. The default value is 5. |

Notes

When you use this command, you can specify one or more of the optional parameters.

Passwords are stored on each storage array in a management domain. If a password was not previously set, you do not need a password. The password can be any combination of alphanumeric characters with a maximum of 30 characters. (You can define a storage array password by using the `set storageArray` command.)

The polling interval and the number of iterations that you specify remain in effect until you end the session. After you end the session, the polling interval and the number of iterations return to their default values.

Minimum Firmware Level

5.20

Set Snapshot Volume

This command defines the properties for a snapshot volume and lets you rename a snapshot volume.

Syntax

```
set (volume [volumeName] |
volumes [volumeName1 ... volumeNameN])
userLabel="snapshotVolumeName"
warningThresholdPercent=percentValue
repositoryFullPolicy=(failBaseWrites | failSnapshot) |
enableSchedule=(TRUE | FALSE) |
schedule=(immediate | snapshotSchedule)
rollbackPriority=(0 | 1 | 2 | 3 | 4)
```

Parameters

| Parameter | Description |
|-------------------|--|
| volume or volumes | The name of the specific snapshot volume for which you want to define properties. (You can enter more than one volume name if you use the <code>volumes</code> parameter). Enclose the snapshot volume name in double quotation marks (" ") inside of square brackets ([]). |

| Parameter | Description |
|-------------------------|--|
| userLabel | A new name that you want to give to a snapshot volume. Enclose the new snapshot volume name in double quotation marks (" "). |
| warningThresholdPercent | The percentage of repository capacity at which you receive a warning that the snapshot repository is nearing full. Use integer values. For example, a value of 70 means 70 percent. The default value is 50. |
| repositoryFullPolicy | How you want snapshot processing to continue if the snapshot repository volume is full. You can choose to fail writes to the base volume (failBaseWrites) or fail writes to the snapshot volume (failSnapshot). The default value is failSnapshot . |
| enableSchedule | Use this parameter to turn on or to turn off the ability to schedule a snapshot operation. To turn on snapshot scheduling, set this parameter to TRUE . To turn off snapshot scheduling, set this parameter to FALSE . |
| schedule | <p>Use this parameter to schedule a snapshot operation.</p> <p>You can use one of these options for setting a schedule for a snapshot operation:</p> <ul style="list-style-type: none"> ▪ immediate ▪ startDate ▪ scheduleDay ▪ startTime ▪ scheduleInterval ▪ endDate ▪ noEndDate ▪ timesPerDay <p>See the Notes section for information explaining how to use these options.</p> |
| rollbackPriority | Use this parameter to determine whether system resources should be allocated to the rollback operation at the expense of system performance. A value of 0 indicates that the rollback operation is prioritized over all other host I/O. A value of 4 indicates that the rollback operation should be performed with minimal impact to host I/O. |

Notes

When you use this command, you can specify one or more of the optional parameters.

You can use any combination of alphanumeric characters, hyphens, and underscores for the names. Names can have a maximum of 30 characters.

You can set the `warningThresholdPercent` parameter and the `repositoryFullPolicy` parameter for both the snapshot repository volume or the snapshot volume.

Scheduling Snapshots

The `enableSchedule` parameter and the `schedule` parameter provide a way for you to schedule automatic snapshots. Using these parameters, you can schedule snapshots daily, weekly, or monthly (by day or by date). The `enableSchedule` parameter turns on or turns off the ability to schedule snapshots. When you enable scheduling, you use the `schedule` parameter to define when you want the snapshots to occur.

This list explains how to use the options for the `schedule` parameter:

- **immediate** – As soon as you enter the command, a snapshot volume is created, and a copy-on-write operation begins.
- **startDate** – A specific date on which you want to create a snapshot volume and perform a copy-on-write operation. The format for entering the date is **MM:DD:YY**. If you do not provide a start date, the current date is used. An example of this option is `startDate=06:27:11`.
- **scheduleDay** – A day of the week on which you want to create a snapshot volume and perform a copy-on-write operation. You can enter these values: **monday**, **tuesday**, **wednesday**, **thursday**, **friday**, **saturday**, **sunday**, and **all**. An example of this option is `scheduleDay=wednesday`.
- **startTime** – The time of a day that you want to create a snapshot volume and start performing a copy-on-write operation. The format for entering the time is **HH:MM**, where **HH** is the hour and **MM** is the minute past the hour. Use a 24-hour clock. For example, 2:00 in the afternoon is 14:00. An example of this option is `startTime=14:27`.
- **scheduleInterval** – An amount of time, in minutes, that you want to have as a minimum between copy-on-write operation. You can possibly create a schedule in which you have overlapping copy-on-write operations because of the duration a copy operation. You can make sure that you have time between copy-on-write operations by using this option. The maximum value for the `scheduleInterval` option is 1440 minutes. An example of this option is `scheduleInterval=180`.
- **endDate** – A specific date on which you want to stop creating a snapshot volume and end the copy-on-write operation. The format for entering the date is **MM:DD:YY**. An example of this option is `endDate=11:26:11`.
- **noEndDate** – Use this option if you do not want your scheduled copy-on-write operation to end. If you later decide to end the copy-on-write operations you must re-enter the **create snapshotVolume** command and specify an end date.
- **timesPerDay** – The number of times that you want the schedule to run in a day. An example of this option is `timesPerDay=4`.

If you also use the `scheduleInterval` option, the firmware chooses between the `timesPerDay` option and the `scheduleInterval` option by selecting the lowest value of the two options. The firmware calculates an integer value for the `scheduleInterval` option by dividing 1440 by the `scheduleInterval` option value that you set. For example, $1440/180 = 8$. The firmware then compares the `timesPerDay` integer value with the calculated `scheduleInterval` integer value and uses the smaller value.

To remove a schedule, use the **delete snapshot** command with the `schedule` parameter. The **delete snapshot** command with the `schedule` parameter deletes only the schedule, not the snapshot volume.

Minimum Firmware Level

6.10

7.77 adds scheduling.

7.80 adds the `rollback` parameter.

Set Storage Array

This command defines the properties of the storage array.

Syntax

```
set storageArray {alarm=(enable | disable | mute) |
{autoSupportConfig (enable | disable) |
cacheBlockSize=cacheBlockSizeValue |
cacheFlushStart=cacheFlushStartSize |
cacheFlushStop=cacheFlushStopSize |
defaultHostType=("hostTypeName" | hostTypeIdentifier)
failoverAlertDelay=delayValue |
mediaScanRate=(disabled | 1-30) |
password="password" |
userLabel="storageArrayName"
isnsRegistration=(TRUE | FALSE))
```

Parameters

| Parameter | Description |
|-------------------|--|
| alarm | <p>The setting for the audible alarm. This parameter has these values:</p> <ul style="list-style-type: none"> enable – The audible alarm is turned on and sounds if a fault occurs. disable – The audible alarm is turned off and does not sound if a fault occurs. mute – The audible alarm is turned off if it is sounding. <p>If another fault occurs after you set the audible alarm to mute, the audible alarm sounds again.</p> |
| autoSupportConfig | <p>The setting for automatically collecting support data each time the firmware detects a critical MEL event. This parameter has these values:</p> <ul style="list-style-type: none"> enable – Turns on the collection of support data disable – Turns off the collection of support data |
| cacheBlockSize | <p>The cache block size that is used by the controller for managing the cache. Valid values are 4 (4 KB), 8 (8 KB), 16 (16 KB), or 32 (32 KB).</p> |

| Parameter | Description |
|--------------------|--|
| cacheFlushStart | The percentage of unwritten data in the cache that causes a cache flush. Use integer values from 0 to 100 to define the percentage. The default value is 80. |
| cacheFlushStop | The percentage of unwritten data in the cache that stops a cache flush in progress. Use integer values from 0 to 100 to define the percentage. This value must be less than the value of the cacheFlushStart parameter. |
| defaultHostType | The default host type of any unconfigured host port to which the controllers are connected. To generate a list of valid host types for the storage array, run the show storageArray hostTypeTable command. Host types are identified by a name or a numerical index. Enclose the host type name in double quotation marks (" "). Do not enclose the host type numerical identifier in double quotation marks. |
| failoverAlertDelay | The failover alert delay time in minutes. The valid values for the delay time are 0 to 60 minutes. The default value is 5. |
| mediaScanRate | The number of days over which the media scan runs. Valid values are disabled , which turns off the media scan, or 1 day to 30 days, where 1 day is the fastest scan rate, and 30 days is the slowest scan rate. A value other than disabled or 1 to 30 does not allow the media scan to function. |
| password | The password for the storage array. Enclose the password in double quotation marks (" "). |
| userLabel | The name for the storage array. Enclose the storage array name in double quotation marks (" "). |
| isnsRegistration | The means of listing the iSCSI target on the iSNS server. Set the parameter to TRUE to list it. |

Notes

When you use this command, you can specify one or more of the optional parameters.

Auto Support Data

When enabled, the `set storageArray autoSupportConfig` command causes all configuration and state information for the storage array to be returned each time a critical Major Event Log (MEL) event is detected. The configuration and state information is returned in the form of an object graph. The object graph contains all relevant logical and physical objects and their associated state information for the storage array.

The `set storageArray autoSupportConfig` command collects configuration and state information in this way:

- Automatic collection of the configuration and state information occurs every 72 hours. The configuration and state information is saved to the storage array zip archive file. The archive file has a time stamp that is used to manage the archive files.
- Two storage array zip archive files are maintained for each storage array. The zip archive files are kept on a drive. After the 72-hour time period is exceeded, the oldest archive file is always overwritten during the new cycle.
- After you enable automatic collection of the configuration and state information using this command, an initial collection of information starts. Collecting information after the you issue the command makes sure that one archive file is available and starts the time stamp cycle.

You can run the `set storageArray autoSupportConfig` command on more than one storage array.

Cache Block Size

When you define cache block sizes, use the 4-KB cache block size for storage arrays that require I/O streams that are typically small and random. Use the 8-KB cache block size when the majority of your I/O streams are larger than 4 KB but smaller than 8 KB. Use the 16-KB cache block size or the 32-KB cache block size for storage arrays that require large data transfer, sequential, or high-bandwidth applications.

The `cacheBlockSize` parameter defines the supported cache block size for all of the volumes in the storage array. Not all controller types support all cache block sizes. For redundant configurations, this parameter includes all of the volumes that are owned by both controllers within the storage array.

Cache Flush Start and Cache Flush Stop

When you define values to start a cache flush, a value that is too low increases the chance that data needed for a host read is not in the cache. A low value also increases the number of drive writes that are necessary to maintain the cache level, which increases system overhead and decreases performance.

When setting storage array cache settings, the value of the `cacheFlushStart` parameter must always be greater than or equal to the value of the `cacheFlushStop` parameter. For example, if the value of the `cacheFlushStart` parameter is set to 80, you may set the value of the `cacheFlushStop` parameter within the range of 0 to 80.

When you define values to stop a cache flush, the lower the value, the higher the chance that the data for a host read requires a drive read rather than reading from the cache.

Default Host Type

When you define host types, if Storage Partitioning is enabled, the default host type affects only those volumes that are mapped in the default group. If Storage Partitioning is not enabled, all of the hosts that are attached to the storage array must run the same operating system and be compatible with the default host type.

Media Scan Rate

Media scan runs on all of the volumes in the storage array that have Optimal status, do not have modification operations in progress, and have the `mediaScanRate` parameter enabled. Use the `set volume` command to enable or disable the `mediaScanRate` parameter.

Password

Passwords are stored on each storage array. For best protection, the password must meet these criteria:

- The password must be between eight and 32 characters long.

- The password must contain at least one uppercase letter.
- The password must contain at least one lowercase letter.
- The password must contain at least one number.
- The password must contain at least one non-alphanumeric character, for example, < > @ +.

 **NOTE** If you are using full disk encryption drives in your storage array, you must use these criteria for your storage array password.

 **NOTE** You must set a password for your storage array before you can create a security key for encrypted full disk encryption drives.

Minimum Firmware Level

5.00 adds the `defaultHostType` parameter.

5.40 adds the `failoverAlertDelay` parameter.

6.14 adds the `alarm` parameter.

7.15 adds more cache block sizes.

Set Storage Array ICMP Response

This command returns the default values for negotiable settings for sessions and connections, which represent the starting point for the storage array for negotiations.

Syntax

```
set storageArray icmpPingResponse=(TRUE | FALSE)
```

Parameter

| Parameter | Description |
|-------------------------------|---|
| <code>icmpPingResponse</code> | This parameter turns on or turns off Echo Request messages. Set the parameter to TRUE to turn on Echo Request messages. Set the parameter to FALSE to turn off Echo Request messages. |

Notes

The Internet Control Message Protocol (ICMP) is used by operating systems in a network to send error messages, test packets, and informational messages related to the IP, such as a requested service is not available or that a host or router could not be reached. The ICMP response command sends ICMP Echo Request messages and receives ICMP Echo Response messages to determine if a host is reachable and the time it takes for packets to get to and from that host.

Minimum Firmware Level

7.10

Set Storage Array iSNS Server IPv4 Address

This command sets the configuration method and address for an IPv4 Internet Storage Name Service (iSNS).

Syntax

```
set storageArray isnsIPv4ConfigurationMethod=[static | dhcp]
isnsIPv4Address=ipAddress
```

Parameters

| Parameters | Description |
|-----------------------------|---|
| isnsIPv4ConfigurationMethod | The method that you want to use to define the iSNS server configuration. You can enter the IP address for the IPv4 iSNS servers by selecting static . For IPv4, you can choose to have a Dynamic Host Configuration Protocol (DHCP) server select the iSNS server IP address by entering dhcp . To enable DHCP, you must set the <i>isnsIPv4Address</i> parameter to 0.0.0.0 . |
| isnsIPv4Address | The IP address that you want to use for the iSNS server. Use this parameter with the static value for IPv4 configurations. If you choose to have a DHCP server set the IP address for an IPv4 Internet iSNS server, you must set the <i>isnsIPv4Address</i> parameter to 0.0.0.0 . |

Notes

The iSNS protocol facilitates the automated discovery, management, and configuration of iSCSI devices and Fibre Channel devices on a TCP/IP network. iSNS provides intelligent storage discovery and management services comparable to those found in Fibre Channel networks, which allow a commodity IP network to function in a similar capacity as a storage area network. iSNS also facilitates a seamless integration of IP networks and Fibre Channel networks, due to its ability to emulate Fibre Channel fabric services and manage both iSCSI devices and Fibre Channel devices.

The DHCP server passes configuration parameters, such as network addresses, to IP nodes. DHCP enables a client to acquire all of the IP configuration parameters that it needs to operate. DHCP lets you automatically allocate reusable network addresses.

Minimum Firmware Level

7.10

Set Storage Array iSNS Server IPv6 Address

This command sets the IPv6 address for the iSNS server.

Syntax

```
set storageArray isnsIPv6Address=ipAddress
```

Parameter

| Parameters | Description |
|-----------------|--|
| isnsIPv6Address | The IPv6 address that you want to use for the iSNS server. |

Notes

The iSNS protocol facilitates the automated discovery, management, and configuration of iSCSI devices and Fibre Channel devices on a TCP/IP network. iSNS provides intelligent storage discovery and management services comparable to those found in Fibre Channel networks, which permits a commodity IP network to function in a similar capacity as a storage area network. iSNS also facilitates a seamless integration of IP networks and Fibre Channel networks, due to its ability to emulate Fibre Channel fabric services, and manage both iSCSI devices and Fibre Channel devices. iSNS provides value in any storage network that has iSCSI devices, Fibre Channel devices, or any combination.

Minimum Firmware Level

7.10

Set Storage Array iSNS Server Listening Port

This command sets the iSNS server listening port.

Syntax

```
set storageArray isnsListeningPort=listeningPortIPAddress
```

Parameter

| Parameter | Description |
|-------------------|--|
| isnsListeningPort | The IP address that you want to use for the iSNS server listening port. The range of values for the listening port is 49152 to 65535. The default value is 3205. |

Notes

A listening port resides on the database server and is responsible for these activities:

- Listening (monitoring) for incoming client connection requests
- Managing the traffic to the server

When a client requests a network session with a server, a listener receives the actual request. If the client information matches the listener information, then the listener grants a connection to the database server.

Minimum Firmware Level

7.10

Set Storage Array iSNS Server Refresh

This command refreshes the network address information for the iSNS server. This command is valid for only IPv4.

Syntax

```
set storageArray isnsServerRefresh
```

Parameters

None.

Notes

If the DHCP server is not operating at full capability, or if the DHCP server is unresponsive, the refresh operation can take between two and three minutes to complete.

The `set storageArray isnsServerRefresh` command returns an error if you did not set the configuration method to DHCP. To set the configuration method to DHCP, use the `set storageArray isnsIPV4ConfigurationMethod` command.

Minimum Firmware Level

7.10

Set Storage Array Learn Cycle

This command sets the learn cycle for the battery backup unit. The learn cycle enables the storage management software to predict the remaining battery life. Learn cycles run at set intervals and store the results for software analysis.

Syntax

```
set storageArray learnCycleDate
(daysToNextLearnCycle=numberOfDays |
day=dayOfTheWeek) time=HH:MM
```

Parameters

| Parameter | Description |
|----------------------|---|
| daysToNextLearnCycle | Valid values are 0 through 7, where 0 is immediately and 7 is in seven days. The daysToNextLearnCycle parameter takes place up to seven days after the next scheduled learn cycle. |
| day | Valid values for the day parameter include the days of the week (Sunday, Monday, Tuesday, Wednesday, Thursday, Friday, and Saturday). Setting the day causes the next learn cycle to be scheduled on the specified day, after the currently scheduled learn cycle. |

| Parameter | Description |
|-----------|--|
| time | The time in 24-hour format; for example 8:00 a.m. is entered as 08:00. Nine o'clock p.m. is entered as 21:00, and 9:30 p.m. is entered as 21:30. |

Notes

You can set the learn cycle to occur only once during a seven-day period.

The `time` parameter selects a specific time that you want to run the learn cycle. If a value is not entered, the command uses a default value of 00:00 (midnight).

If the day and time specified are in the past, the next learn cycle takes place on the next possible day specified.

Minimum Firmware Level

7.15

Set Storage Array Redundancy Mode

This command sets the redundancy mode of the storage array to either simplex or duplex.

Syntax

```
set storageArray redundancyMode=(simplex | duplex)
```

Parameter

| Parameter | Description |
|----------------|--|
| redundancyMode | Use simplex mode when you have a single controller. Use duplex mode when you have two controllers. |

Minimum Firmware Level

6.10

Set Storage Array Remote Status Notification

This command sets or changes the proxy configuration settings for the remote status notification feature. The proxy configuration settings are saved in the `devmgr.datadir\monitor\EMRSstate\EMRSRuntimeConfig.xml` file on the storage management station.

Syntax

```
set remoteStatusNotification proxyConfig
(PACProxy=proxyLocationURL | [proxyHost=hostURL] |
[proxyPort=hostPort])
```

Parameters

| Parameter | Description |
|------------------|--|
| PACProxy | The URL for the location of a proxy auto-config (PAC) file. The file defines the proxy server to be used for remote status notification. |
| proxyHost | The URL for a host that is to be used for remote status notification. |
| proxyPort | The port number of a host that is to be used for remote status notification. |

Minimum Firmware Level

7.70

Set Storage Array Security Key

Use this command to set the security key that is used throughout the storage array to implement the SafeStore Drive Security premium feature. When any security-capable drive in the storage array is assigned to a secured volume group, that drive will be security-enabled using the security key. Before you can set the security key, you must use the **create storageArray securityKey** command to create the security key.

Syntax

```
set storageArray securityKey
```

Parameters

None.

Notes

Security-capable drives have hardware to accelerate cryptographic processing and each has a unique drive key. A security-capable drive behaves like any other drive until it is added to a secured volume group, at which time the security-capable drive becomes security-enabled.

Whenever a security-enabled drive is powered on, it requires the correct security key from the controller before it can read or write data. So, a security-enabled drive uses two keys: the drive key that encrypts and decrypts the data and the security key that authorizes the encryption and decryption processes. The **set storageArray securityKey** command commits the security key to all of the controllers and security-enabled drives in the storage array. The full disk encryption feature ensures that if a security-enabled drive is physically removed from a storage array, its data cannot be read by any other device unless the security key is known.

Minimum Firmware Level

7.50

Set Storage Array Time

This command sets the clocks on both controllers in a storage array by synchronizing the controller clocks with the clock of the host from which you run this command.

Syntax

```
set storageArray time
```

Parameters

None.

Minimum Firmware Level

6.10

Set Storage Array Tray Positions

This command defines the position of the trays in a storage array. You must include all of the trays in the storage array when you enter this command.

Syntax

```
set storageArray trayPositions=(controller | trayID ... trayIDn)
```

Parameter

| Parameter | Description |
|---------------|---|
| trayPositions | A list of all of the tray IDs. The sequence of the tray IDs in the list defines the positions for the controller tray and the drive trays in a storage array. Valid values are 0 to 99. Enter the tray ID values separated with a space. Enclose the list of tray ID values in parentheses. For storage arrays where the controller tray has a predefined identifier that is not in the range of valid tray position values, use the controller value. |

Notes

This command defines the position of a tray in a storage array by the position of the tray ID in the `trayPositions` list. For example, if you have a controller tray with an ID set to 84 and drive trays with IDs set to 1, 12, and 50, the `trayPositions` sequence (84 1 12 50) places the controller tray in the first position, drive tray 1 in the second position, drive tray 12 in the third position, and drive tray 50 in the fourth position. The `trayPositions` sequence (1 84 50 12) places the controller tray in the second position, drive tray 1 in the first position, drive tray 50 in the third position, and drive tray 12 in the fourth position.



NOTE You must include all of the trays in the storage array in the list defined by the `trayPositions` parameter. If the number of trays in the list does not match the total number of trays in the storage array, an error message appears.

Minimum Firmware Level

6.10

For 6.14 and 6.16, `controller` is not a valid value.

Set Storage Array Unnamed Discovery Session

This command enables the storage array to participate in unnamed discovery sessions.

Syntax

```
set storageArray unnamedDiscoverySession=(TRUE | FALSE)
```

Parameter

| Parameter | Description |
|-------------------------|--|
| unnamedDiscoverySession | This parameter turns on or turns off unnamed discovery sessions. Set the parameter to TRUE to turn on unnamed discovery sessions. Set the parameter to FALSE to turn off unnamed discovery sessions. |

Notes

Discovery is the process where initiators determine the targets that are available. Discovery occurs at power-on/initialization and also if the bus topology changes, for example, if an extra device is added.

An unnamed discovery session is a discovery session that is established without specifying a target ID in the login request. For unnamed discovery sessions, neither the target ID nor the target portal group ID are available to the targets.

Minimum Firmware Level

7.10

Set Tray Alarm

This command turns on, turns off, or mutes the audible alarm for a specific tray or all of the trays in a storage array.

Syntax

```
set (allTrays | tray [trayID]  
alarm=(enable | disable | mute))
```

Parameters

| Parameter | Description |
|-----------|---|
| allTrays | The setting to select all of the trays in a storage array that have audible alarms that you want to turn on, turn off, or mute. |

| Parameter | Description |
|-----------|---|
| tray | The specific tray that has the audible alarm that you want to turn on, turn off, or mute. Tray ID values are 0 to 99. Enclose the tray ID value in square brackets ([]). |
| alarm | The setting for the audible alarm. This alarm has these values: <ul style="list-style-type: none"> ▪ enable – The audible alarm is turned on and sounds if a fault occurs. ▪ disable – The audible alarm is turned off and does not sound if a fault occurs. ▪ mute – The audible alarm is turned off if it is sounding. (If another fault occurs after you set the audible alarm to mute , the audible alarm sounds again.) |

Minimum Firmware Level

6.16

Set Tray Identification

This command sets the tray ID of a controller tray, a controller-drive tray, or a drive tray in a storage array. This command is valid only for controller trays, controller-drive trays, or drive trays that have tray IDs that you can set through the controller firmware. You cannot use this command for controller trays, controller-drive trays, or drive trays that have a tray ID that you set with a switch.

Syntax

```
set tray ["serialNumber"] id=trayID
```

Parameters

| Parameter | Description |
|-----------|---|
| tray | The serial number of the controller tray, controller-drive tray, or the drive tray for which you are setting the tray ID. Serial numbers can be any combination of alphanumeric characters and any length. Enclose the serial number in double quotation marks (" "). |
| id | The value for the controller tray tray ID, controller-drive tray tray ID, or the drive tray tray ID. Tray ID values are 0 through 99. You do not need to enclose the tray ID value in parentheses. |

Notes

This command originally supported the CE6998 controller tray. The CE6998-series controller trays can connect to a variety of drive trays, including those whose tray IDs are set by switches. When connecting a CE6998-series controller tray to drive trays whose tray IDs are set by switches, valid values for tray IDs for the controller tray are 80 through 99. This range avoids conflicts with tray IDs that are used for attached drive trays.

Minimum Firmware Level

6.14 adds support for the CE6998 controller tray.

6.16 adds support for controller trays, controller-drive trays, and drive trays that have tray IDs set through the controller firmware.

Set Tray Service Action Allowed Indicator

This command turns on or turns off the Service Action Allowed indicator light on a power-fan canister, an interconnect-battery canister, or an environmental services monitor (ESM) canister. If the storage array does not support the Service Action Allowed indicator light feature, this command returns an error. If the storage array supports the command but is unable to turn on or turn off the indicator light, this command returns an error.

To turn on or turn off the Service Action Allowed indicator light on the controller canister, use the **set controller serviceAllowedIndicator** command.

Syntax

```
set tray [trayID]
(powerFan [(left | right | top | bottom)] |
interconnect |
esm [(left | right | top | bottom)]) |
battery [(left | right)] |
serviceAllowedIndicator=(on | off)
```

Parameters

| Parameter | Description |
|------------------|--|
| tray | The tray where the power-fan canister, the interconnect canister, the ESM canister, or the battery canister resides. Tray ID values are 0 to 99. Enclose the tray ID value in square brackets ([]). If you do not enter a tray ID value, the tray ID of the controller tray is the default value. |
| powerFan | The Service Action Allowed indicator light on the power-fan canister that you want to turn on or turn off. Valid power-fan canister identifiers are left , right , top , or bottom . Enclose the power-fan canister identifier in square brackets ([]). |
| interconnect | The Service Action Allowed indicator light for the interconnect-battery canister. |
| esm | The Service Action Allowed indicator light for an ESM canister. Valid ESM canister identifiers are left , right , top , or bottom . |
| battery | The Service Action Allowed indicator light for a battery. Valid battery identifiers are left or right . |

| Parameter | Description |
|-------------------------|--|
| serviceAllowedIndicator | The setting to turn on or turn off the Service Action Allowed indicator light. To turn on the Service Action Allowed indicator light, set this parameter to on . To turn off the Service Action Allowed indicator light, set this parameter to off . |

Example

This command turns on the Service Action Allowed indicator light for the left ESM in tray 5 with the IP address of 155.155.155.155.

```
SMcli 123.145.167.214 123.145.167.215 -c "set tray [5]
ESM [left] serviceAllowedIndicator=on;"
```

Notes

This command was originally defined for use with the CE6998 controller tray. This command is not supported by controller trays that were shipped before the introduction of the CE6998 controller tray.

Minimum Firmware Level

6.14 adds these parameters:

- powerFan
- interconnect

6.16 adds these parameters:

- tray
- esm

7.60 adds the identifiers `top` and `bottom`.

Set Volume

This command defines the properties for a volume. You can use most parameters to define properties for one or more volumes. You also can use some parameters to define properties for only one volume. The syntax definitions are separated to show which parameters apply to several volumes and which apply to only one volume. Also, the syntax for volume mapping is listed separately.



NOTE In configurations where volume groups consist of more than 32 volumes, the operation can result in host I/O errors or internal controller reboots due to the expiration of the timeout period before the operation completes. If you experience host I/O errors or internal controller reboots, quiesce the host I/O and try the operation again.

Syntax Applicable to One or More Volumes

```
set (allVolumes | volume ["volumeName"] |
volumes ["volumeName1" ... "volumeNameN"] | volume <wwID>)
cacheFlushModifier=cacheFlushModifierValue
cacheWithoutBatteryEnabled=(TRUE | FALSE)
```

```

mediaScanEnabled=(TRUE | FALSE)
mirrorCacheEnabled=(TRUE | FALSE)
modificationPriority=(highest | high | medium | low | lowest)
owner=(a | b)
readCacheEnabled=(TRUE | FALSE)
writeCacheEnabled=(TRUE | FALSE)
cacheReadPrefetch=(TRUE | FALSE)
dataAssuranceDisabled=(TRUE | FALSE)

set (allVolumes | volume ["volumeName"] |
volumes ["volumeName1" ... "volumeNameN"] | volume <wwID>)
cacheFlushModifier=cacheFlushModifierValue
cacheWithoutBatteryEnabled=(TRUE | FALSE)
mediaScanEnabled=(TRUE | FALSE)
mirrorCacheEnabled=(TRUE | FALSE)
modificationPriority=(highest | high | medium | low | lowest)
owner=(a | b)
preReadRedundancyCheck=(TRUE | FALSE)
readCacheEnabled=(TRUE | FALSE)
writeCacheEnabled=(TRUE | FALSE)
cacheReadPrefetch=(TRUE | FALSE)
dataAssuranceDisabled=(TRUE | FALSE)

```

Syntax Applicable to Only One Volume

```

set (volume ["volumeName"] | volume <wwID>)
addCapacity=volumeCapacity
[addDrives=(trayID1,drawerID1,slotID1 ... trayIDn,drawerIDn,slotIDn)]
redundancyCheckEnabled=(TRUE | FALSE)
segmentSize=segmentSizeValue
userLabel=volumeName
preReadRedundancyCheck=(TRUE | FALSE)

```

Syntax Applicable to Volume Mapping

```

set (volume ["volumeName"] | volume <wwID> | accessVolume)
logicalUnitNumber=LUN
(host="hostName" |
hostGroup=("hostGroupName" | defaultGroup)

```

Parameters

| Parameter | Description |
|-------------------|---|
| allVolumes | The properties for all volumes in the storage array. |
| volume or volumes | The name of the specific volume for which you want to define properties. (You can enter more than one volume name if you use the volumes parameter.) Enclose the volume name in double quotation marks (") inside of square brackets ([]). |

| Parameter | Description |
|----------------------------|--|
| volume | The World Wide Identifier (WWID) of the volume for which you are setting properties. You can use the WWID instead of the volume name to identify the volume. Enclose the WWID in angle brackets (< >). |
| cacheFlushModifier | The maximum amount of time that data for the volume stays in cache before the data is flushed to physical storage. Valid values are listed in the Notes section. |
| cacheWithoutBatteryEnabled | The setting to turn on or turn off caching without batteries. To turn on caching without batteries, set this parameter to TRUE . To turn off caching without batteries, set this parameter to FALSE . |
| mediaScanEnabled | The setting to turn on or turn off media scan for the volume. To turn on media scan, set this parameter to TRUE . To turn off media scan, set this parameter to FALSE . (If media scan is disabled at the storage array level, this parameter has no effect.) |
| mirrorCacheEnabled | The setting to turn on or turn off the mirror cache. To turn on the mirror cache, set this parameter to TRUE . To turn off the mirror cache, set this parameter to FALSE . |
| modificationPriority | The priority for volume modifications while the storage array is operational. Valid values are highest , high , medium , low , or lowest . |
| owner | The controller that owns the volume. Valid controller identifiers are a or b , where a is the controller in slot A, and b is the controller in slot B. Use this parameter only if you want to change the volume owner. |
| preReadRedundancyCheck | <p>The setting to turn on or turn off pre-read redundancy checking. Turning on pre-read redundancy checking verifies the consistency of RAID redundancy data for the stripes containing the read data. Pre-read redundancy checking is performed on read operations only. To turn on pre-read redundancy checking, set this parameter to TRUE. To turn off pre-read redundancy checking, set this parameter to FALSE.</p> <hr/> <p>NOTE Do not use this parameter on non-redundant volumes, such as RAID 0 volumes.</p> <hr/> |

| Parameter | Description |
|-----------------------|--|
| readCacheEnabled | The setting to turn on or turn off the read cache. To turn on the read cache, set this parameter to TRUE . To turn off the read cache, set this parameter to FALSE . |
| writeCacheEnabled | The setting to turn on or turn off the write cache. To turn on the write cache, set this parameter to TRUE . To turn off the write cache, set this parameter to FALSE . |
| cacheReadPrefetch | The setting to turn on or turn off cache read prefetch. To turn off cache read prefetch, set this parameter to FALSE . To turn on cache read prefetch, set this parameter to TRUE . |
| dataAssuranceDisabled | <p>The setting to turn on or turn off data assurance for a specific volume. For this parameter to have meaning, your volume must be capable of data assurance. This parameter changes a volume from one that supports data assurance to a volume that cannot support data assurance. To remove data assurance from a volume that supports data assurance, set this parameter to TRUE. To return a volume to supporting data assurance, set this parameter to FALSE.</p> <hr/> <p>NOTE If you remove data assurance from a volume, you cannot reset data assurance for that volume.</p> <hr/> <p>To reset data assurance for the data on a volume, from which you removed data assurance, perform these steps:</p> <ol style="list-style-type: none"> 1. Remove the data from the volume. 2. Delete the volume. 3. Recreate a new volume with the properties of the deleted volume. 4. Set data assurance for the new volume. 5. Move the data to the new volume. |
| dataAssuranceDisabled | The setting to turn on or turn off data assurance for a specific volume. For this parameter to have meaning, your volume must be capable of data assurance. This parameter changes a volume from one that supports data assurance to a volume that cannot support data assurance. |

| Parameter | Description |
|------------------------|--|
| | <p>To remove data assurance from a volume that supports data assurance, set this parameter to TRUE. To return a volume to supporting data assurance, set this parameter to FALSE.</p> <hr/> <p>NOTE If you remove data assurance from a volume, you cannot reset data assurance for that volume.</p> <hr/> <p>To reset data assurance for the data on a volume, from which you removed data assurance, perform these steps:</p> <ol style="list-style-type: none"> 1. Remove the data from the volume. 2. Delete the volume. 3. Recreate a new volume with the properties of the deleted volume. 4. Set data assurance for the new volume. 5. Move the data to the new volume. |
| addCapacity | The setting to increase the storage size (capacity) of the volume for which you are defining properties. Size is defined in units of bytes , KB , MB , GB , or TB . The default value is bytes . |
| addDrives | The setting to add new drives to the volume. For high-capacity drive trays, specify the tray ID value, the drawer ID value, and the slot ID value for the drive. For low-capacity drive trays, specify the tray ID value and the slot ID value for the drive. Tray ID values are 0 to 99. Drawer ID values are 1 to 5. Slot ID values are 1 to 32. Enclose the tray ID value, drawer ID value, and the slot ID value in parentheses. Use this parameter with the <code>addCapacity</code> parameter if you need to specify additional drives to accommodate the new size. |
| redundancyCheckEnabled | The setting to turn on or turn off redundancy checking during a media scan. To turn on redundancy checking, set this parameter to TRUE . To turn off redundancy checking, set this parameter to FALSE . |
| segmentSize | The amount of data (in KB) that the controller writes on a single drive in a volume before writing data on the next drive. Valid values are 8 , 16 , 32 , 64 , 128 , 256 , or 512 . |

| Parameter | Description |
|------------------------|--|
| userLabel | The new name that you want to give an existing volume. Enclose the new volume name in double quotation marks (" "). |
| preReadRedundancyCheck | The setting to check the consistency of RAID redundancy data on the stripes during read operations. Do not use this operation for non-redundant volumes, for example RAID Level 0. To check redundancy consistency, set this parameter to TRUE . For no stripe checking, set this parameter to FALSE . |
| accessVolume | The logical unit number for the access volume. The logical unit number is the only property that you can set for the access volume. |
| logicalUnitNumber | The logical unit number that you want to use to map to a specific host. This parameter also assigns the host to a host group. |
| host | The name of the host to which the volume is mapped. Enclose the host name in double quotation marks (" "). |
| hostGroup | The name of the host group to which the volume is mapped. Enclose the host group name in double quotation marks (" "). defaultGroup is the host group that contains the host to which the volume is mapped. |

Notes

Host I/O errors might result in volume groups with more than 32 volumes. This operation might also result in internal controller reboots due to the expiration of the timeout period before the operation completes. If you experience this issue, quiesce host I/O, and try the operation again.

When you use this command, you can specify one or more of the optional parameters.

You can apply these parameters to only one volume at a time:

- addCapacity
- segmentSize
- userLabel
- logicalUnitNumber

Add Capacity, Add Drives, and Segment Size

Setting the `addCapacity` parameter, the `addDrives` parameter, or the `segmentSize` parameter starts a long-running operation that you cannot stop. These long-running operations are performed in the background and do not prevent you from running other commands. To show the progress of long-running operations, use the `show volume actionProgress` command.

The `addDrives` parameter supports both high-capacity drive trays and low-capacity drive trays. A high-capacity drive tray has drawers that hold the drives. The drawers slide out of the drive tray to provide access to the drives. A low-capacity drive tray does not have drawers. For a high-capacity drive tray, you must specify the identifier (ID) of the drive tray, the ID of the drawer, and the ID of the slot in which a drive resides. For a low-capacity drive tray, you need only specify the ID of the drive tray and the ID of the slot in which a drive resides. For a low-capacity drive tray, an alternative method for identifying a location for a drive is to specify the ID of the drive tray, set the ID of the drawer to 0, and specify the ID of the slot in which a drive resides.

Access Volume

The access volume is the volume in a SAN environment that is used for in-band communication between the storage management software and the storage array controller. This volume uses a LUN address and consumes 20 MB of storage space that is not available for application data storage. An access volume is required only for in-band managed storage arrays. If you specify the `accessVolume` parameter, the only property you can set is the `logicalUnitNumber` parameter.

Cache Flush Modifier

Valid values for the cache flush modifier are listed in this table.

| Value | Description |
|------------------|---|
| Immediate | Data is flushed as soon as it is placed into the cache. |
| 250 | Data is flushed after 250 ms. |
| 500 | Data is flushed after 500 ms. |
| 750 | Data is flushed after 750 ms. |
| 1 | Data is flushed after 1 s. |
| 1500 | Data is flushed after 1500 ms. |
| 2 | Data is flushed after 2 s. |
| 5 | Data is flushed after 5 s. |
| 10 | Data is flushed after 10 s. |
| 20 | Data is flushed after 20 s. |
| 60 | Data is flushed after 60 s (1 min.). |
| 120 | Data is flushed after 120 s (2 min.). |
| 300 | Data is flushed after 300 s (5 min.). |

| Value | Description |
|-----------------|--|
| 1200 | Data is flushed after 1200 s (20 min.). |
| 3600 | Data is flushed after 3600 s (1 hr). |
| Infinite | Data in cache is not subject to any age or time constraints. The data is flushed based on other criteria that are managed by the controller. |

Cache Without Battery Enabled

Write caching without batteries enables write caching to continue if the controller batteries are completely discharged, not fully charged, or not present. If you set this parameter to **TRUE** without an uninterruptible power supply (UPS) or other backup power source, you can lose data if the power to the storage array fails. This parameter has no effect if write caching is disabled.

Modification Priority

Modification priority defines the amount of system resources that are used when modifying volume properties. If you select the highest priority level, the volume modification uses the most system resources, which decreases the performance for host data transfers.

Cache Read Prefetch

The `cacheReadPrefetch` parameter enables the controller to copy additional data blocks into cache while the controller reads and copies data blocks that are requested by the host from the drive into cache. This action increases the chance that a future request for data can be fulfilled from cache. Cache read prefetch is important for multimedia applications that use sequential data transfers. The configuration settings for the storage array that you use determine the number of additional data blocks that the controller reads into cache. Valid values for the `cacheReadPrefetch` parameter are **TRUE** or **FALSE**.

Segment Size

The size of a segment determines how many data blocks that the controller writes on a single drive in a volume before writing data on the next drive. Each data block stores 512 bytes of data. A data block is the smallest unit of storage. The size of a segment determines how many data blocks that it contains. For example, an 8-KB segment holds 16 data blocks. A 64-KB segment holds 128 data blocks.

When you enter a value for the segment size, the value is checked against the supported values that are provided by the controller at run time. If the value that you entered is not valid, the controller returns a list of valid values. Using a single drive for a single request leaves other drives available to simultaneously service other requests.

If the volume is in an environment where a single user is transferring large units of data (such as multimedia), performance is maximized when a single data transfer request is serviced with a single data stripe. (A data stripe is the segment size that is multiplied by the number of drives in the volume group that are used for data transfers.) In this case, multiple drives are used for the same request, but each drive is accessed only once.

For optimal performance in a multiuser database or file system storage environment, set your segment size to minimize the number of drives that are required to satisfy a data transfer request.

Minimum Firmware Level

5.00 adds the `addCapacity` parameter.

7.10 adds the `preReadRedundancyCheck` parameter.

7.60 adds the `drawerID` user input.

7.75 adds the `dataAssuranceDisabled` parameter.

Set Volume Copy

This command defines the properties for a volume copy pair.

Syntax

```
set volumeCopy target [targetName]
[source [sourceName]]
copyPriority=(highest | high | medium | low | lowest)
targetReadOnlyEnabled=(TRUE | FALSE)
copyType=(online | offline)
```

Parameters

| Parameter | Description |
|------------------------------------|---|
| <code>target</code> | The name of the target volume for which you want to define properties. Enclose the target volume name in square brackets ([]). If the target volume name has special characters, you also must enclose the target volume name in double quotation marks (" "). |
| <code>source</code> | The name of the source volume for which you want to define properties. Enclose the source volume name in square brackets ([]). If the source volume name has special characters, you also must enclose the source volume name in double quotation marks (" "). |
| <code>copyPriority</code> | The priority that the volume copy has relative to host I/O activity. Valid values are highest , high , medium , low , or lowest . |
| <code>targetReadOnlyEnabled</code> | The setting so that you can write to the target volume or only read from the target volume. To write to the target volume, set this parameter to FALSE . To prevent writing to the target volume, set this parameter to TRUE . |
| <code>copyType</code> | Use this parameter to identify that a volume copy has a snapshot. If the volume copy has a snapshot, set this parameter to online . If the volume copy does not have a snapshot, set this parameter to offline . |

Notes

When you use this command, you can specify one or more of the optional parameters.

Minimum Firmware Level

5.40

7.77 adds creating a volume copy with snapshot.

Set Volume Group

This command defines the properties for a volume group.

Syntax

```
set volumeGroup [volumeGroupName]
addDrives=(trayID1,drawerID1,slotID1 ... trayIDn,drawerIDn,slotIDn)
raidLevel=(0 | 1 | 3 | 5 | 6)
owner=(a | b)
```

Parameters

| Parameter | Description |
|-------------|---|
| volumeGroup | The alphanumeric identifier (including - and _) of the volume group for which you want to set properties. Enclose the volume group identifier in square brackets ([]). |
| addDrives | The location of the drive that you want to add to the volume group. For high-capacity drive trays, specify the tray ID value, the drawer ID value, and the slot ID value for the drive. For low-capacity drive trays, specify the tray ID value and the slot ID value for the drive. Tray ID values are 0 to 99. Drawer ID values are 1 to 5. Slot ID values are 1 to 32. Enclose the tray ID value, the drawer ID value, and the slot ID value in parentheses. |
| raidLevel | The RAID level for the volume group. Valid values are 0, 1, 3, 5, or 6. |
| owner | The controller that owns the volume group. Valid controller identifiers are a or b , where a is the controller in slot A, and b is the controller in slot B. Use this parameter only if you want to change the volume group owner. |

Notes

Host I/O errors might result in volume groups with more than 32 volumes. This operation also might result in internal controller reboots because the timeout period ends before the volume group definition is set. If you experience this issue, quiesce the host I/O operations, and try the command again.

When you use this command, you can specify one or more of the parameters.



NOTE Specifying the `addDrives` parameter or the `raidLevel` parameter starts a long-running operation that you cannot stop.

The `addDrives` parameter supports both high-capacity drive trays and low-capacity drive trays. A high-capacity drive tray has drawers that hold the drives. The drawers slide out of the drive tray to provide access to the drives. A low-capacity drive tray does not have drawers. For a high-capacity drive tray, you must specify the identifier (ID) of the drive tray, the ID of the drawer, and the ID of the slot in which a drive resides. For a low-capacity drive tray, you need only specify the ID of the drive tray and the ID of the slot in which a drive resides. For a low-capacity drive tray, an alternative method for identifying a location for a drive is to specify the ID of the drive tray, set the ID of the drawer to 0, and specify the ID of the slot in which a drive resides.

Minimum Firmware Level

6.10

7.10 adds RAID 6 capability.

7.30 removes the `availability` parameter.

7.60 adds the `drawerID` user input.

Set Volume Group Forced State

This command moves a volume group into a Forced state. Use this command if the `start volumeGroup import` command does not move the volume group to an Imported state or if the import operation does not work because of hardware errors. In a Forced state, the volume group can be imported, and you can then identify the hardware errors.

Syntax

```
set volumeGroup [volumeGroupName] forcedState
```

Parameter

| Parameter | Description |
|--------------------------|---|
| <code>volumeGroup</code> | The alphanumeric identifier (including - and _) of the volume group that you want to place in a Forced state. Enclose the volume group identifier in square brackets ([]). |

Notes

You can move the drives that comprise a volume group from one storage array to another storage array. The CLI provides three commands that let you move the drives. The commands are `start volumeGroup export`, `start volumeGroup import`, and `set volumeGroup forcedState`.

In the Forced state, you can perform an import operation on the volume group.

Minimum Firmware Level

7.10

Show Cache Backup Device Diagnostic Status

This command returns the status of backup device diagnostic tests started by the **start cacheBackupDevice diagnostic** command. If the diagnostics have finished, all of the results of the diagnostic tests are shown. If the diagnostics have not finished, only the results of the diagnostic tests that finished are shown. The results of the test are shown on the terminal, or you can write the results to a file.

Syntax

```
show cacheBackupDevice controller [(a | b)] diagnosticStatus [file="fileName"]
```

Parameters

| Parameter | Description |
|------------|--|
| controller | The controller that has the cache backup device on which you are running the diagnostic tests. Valid controller identifiers are a or b , where a is the controller in slot A, and b is the controller in slot B. Enclose the controller identifier in square brackets ([]). If you do not specify a controller, the storage management software returns a syntax error. |
| file | The name of the file that contains the result of the diagnostic tests. Enclose the file name in double quotation marks (" "). This command does not automatically append a file extension to the file name. You must add an extension when you enter the file name. |

Minimum Firmware Level

7.60 adds the capability for cache backup device diagnostics.

Show Cache Memory Diagnostic Status

This command returns the status of cache memory diagnostics started by the **start controller diagnostic** command. If the diagnostics have finished, all of the results of the diagnostic tests are shown. If all of the diagnostics have not finished, only the results of the diagnostic tests that finished are shown.

Syntax

```
show cacheMemory controller [(a | b)] diagnosticStatus file="fileName"
```

Parameters

| Parameter | Description |
|------------|---|
| controller | The controller that has the cache memory on which you are running the diagnostic tests. Valid controller identifiers are a or b , where a is the controller in slot A, and b is the controller in slot B. Enclose the controller identifier in square brackets ([]). |
| file | The name of the file that contains the result of the diagnostic tests. Enclose the file name in double quotation marks (" "). |

| Parameter | Description |
|-----------|---|
| | This command does not automatically append a file extension to the file name. You must add an extension when you enter the file name. |

Minimum Firmware Level

7.60 adds the capability for the cache memory diagnostics.

Show Controller

For each controller in a storage array, this command returns the following information:

- The status (Online or Offline)
- The current firmware and NVSRAM configuration
- The pending firmware configuration and NVSRAM configuration (if any)
- The board ID
- The product ID
- The product revision
- The serial number
- The date of manufacture
- The cache size or the processor size
- The date and the time to which the controller is set
- The associated volumes (including the preferred owner)
- The Ethernet port
- The physical disk interface
- The host interface, which applies only to Fibre Channel host interfaces

Syntax

```
show (allControllers | controller [(a | b)]) [summary]
```

Parameters

| Parameter | Description |
|----------------|---|
| allControllers | The setting to return information about both controllers in the storage array. |
| controller | The setting to return information about a specific controller in the storage array. Valid controller identifiers are a or b , where a is the controller in slot A, and b is the controller in slot B. Enclose the controller identifier in square brackets ([]). |
| summary | The setting to return a concise list of information about both controllers in the storage array. |

Notes

The following list is an example of the information that is returned by the `show controller` command. This example only shows how the information is presented and should not be considered to represent best practice for a storage array configuration.

```
Controller in slot A
  Status: Online
  Current configuration
    Firmware version: 96.10.21.00
    Appware version: 96.10.21.00
    Bootware version: 96.10.21.00
    NVSRAM version: N4884-610800-001
  Pending configuration
    Firmware version: Not applicable
    Appware version: Not applicable
    Bootware version: Not applicable
    NVSRAM version: Not applicable
    Transferred on: Not applicable
  Board ID: 4884
  Product ID: INF-01-00
  Product revision: 9610
  Serial number: 1T14148766
  Date of manufacture: October 14, 2006
  Cache/processor size (MB): 1024/128
  Date/Time: Wed Feb 18 13:55:53 MST 2008
  Associated Volumes (* = Preferred Owner):
    1*, 2*, CTL 0 Mirror Repository*, Mirror Repository 1*,
    JCG_Remote_MirrorMenuTests*
  Ethernet port: 1
    MAC address: 00:a0:b8:0c:c3:f5
    Host name: ausctlr9
    Network configuration: Static
    IP address: 172.22.4.249
    Subnet mask: 255.255.255.0
    Gateway: 172.22.4.1
    Remote login: Enabled
  Drive interface: Fibre
    Channel: 1
    Current ID: 125/0x1
    Maximum data rate: 2 Gbps
    Current data rate: 1 Gbps
    Data rate control: Switch
    Link status: Up
  Drive interface: Fibre
    Channel: 2
    Current ID: 125/0x1
    Maximum data rate: 2 Gbps
    Current data rate: 1 Gbps
    Data rate control: Switch
    Link status: Up
  Drive interface: Fibre
    Channel: 3
    Current ID: 125/0x1
    Maximum data rate: 2 Gbps
    Current data rate: 1 Gbps
```



```

    Data rate control: Switch
    Link status: Up
Drive interface: Fibre
    Channel: 4
    Current ID: 125/0x1
    Maximum data rate: 2 Gbps
    Current data rate: 1 Gbps
    Data rate control: Switch
    Link status: Up
Host interface: Fibre
    Port: 1
    Current ID: Not applicable/0xFFFFFFFF
    Preferred ID: 126/0x0
    NL-Port ID: 0x011100
    Maximum data rate: 2 Gbps
    Current data rate: 1 Gbps
    Data rate control: Switch
    Link status: Up
    Topology: Fabric Attach
    World-wide port name: 20:2c:00:a0:b8:0c:c3:f6
    World-wide node name: 20:2c:00:a0:b8:0c:c3:f5
    Part type: HPFC-5200    revision 10
Host interface: Fibre
    Port: 2
    Current ID: Not applicable/0xFFFFFFFF
    Preferred ID: 126/0x0
    NL-Port ID: 0x011100
    Maximum data rate: 2 Gbps
    Current data rate: 1 Gbps
    Data rate control: Switch
    Link status: Up
    Topology: Fabric Attach
    World-wide port name: 20:2c:00:a0:b8:0c:c3:f7
    World-wide node name: 20:2c:00:a0:b8:0c:c3:f5
    Part type: HPFC-5200    revision 10

```

When you use the `summary` parameter, the command returns the list of information without the drive channel information and the host channel information.

The `show storageArray` command also returns detailed information about the controller.

Minimum Firmware Level

5.43 adds the `summary` parameter.

Show Controller Diagnostic Status

This command returns the status of controller diagnostics started by the `start controller diagnostic` command. If the diagnostics have finished, the entire results of the diagnostic tests are shown. If the diagnostic tests have not finished, only the results of the of the tests that are finished are shown. The results of the test are shown on the terminal, or you can write the results to a file.

Syntax

```
show controller [(a | b)] diagnosticStatus [file=filename]
```

Parameters

| Parameter | Description |
|------------|---|
| controller | The setting to return information about a specific controller in the storage array. Valid controller identifiers are a or b , where a is the controller in slot A, and b is the controller in slot B. Enclose the controller identifier in square brackets ([]). |
| file | The name of the file that contains the results of the diagnostic tests. This command does not automatically append a file extension to the file name. You must add an extension when you enter the file name. |

Minimum Firmware Level

7.70 adds the capability for controller diagnostic status.

Show Controller NVSRAM

This command returns a list of the NVSRAM byte values for the specified host type. If you do not enter the optional parameters, this command returns a list of all of the NVSRAM byte values. To view an example of a table of NVSRAM values that are returned by this command, refer to the "Examples of Information Returned by the Show Command" appendix in Configuring and Maintaining a Storage Array Using the Command Line Interface document.

Syntax

```
show (allControllers | controller [(a | b)])
NVSRAM [hostType=hostTypeIndexLabel | host="hostName"]
```

Parameters

| Parameter | Description |
|----------------|---|
| allControllers | The setting to return information about both controllers in the storage array. |
| controller | The setting to return information about a specific controller in the storage array. Valid controller identifiers are a or b , where a is the controller in slot A, and b is the controller in slot B. Enclose the controller identifier in square brackets ([]). |
| hostType | The index label or number of the host type. Use the show storageArray hostTypeTable command to generate a list of available host type identifiers. |
| host | The name of the host that is connected to the controllers. Enclose the host name in double quotation marks (" "). |

Notes

Use the **show controller NVSRAM** command to show parts of or all of the NVSRAM before using the **set controller** command to change the NVSRAM values. Before making any changes to the NVSRAM, contact your Customer and Technical Support representative to learn what regions of the NVSRAM you can modify.

Minimum Firmware Level

6.10

Show Current iSCSI Sessions

This command returns information about an iSCSI session for either an iSCSI initiator or an iSCSI target.

Syntax

```
show iscsiInitiator ["initiatorName"] iscsiSessions
```

```
show iscsiTarget ["targetName"] iscsiSessions
```

Parameters

| Parameter | Description |
|----------------|---|
| iscsiInitiator | The name of the iSCSI initiator for which you want to obtain session information. Enclose the iSCSI initiator name in double quotation marks (" "). You must also enclose the name in either square brackets ([]) or angle brackets (< >). |
| iscsiTarget | The name of the iSCSI target for which you want to obtain session information. Enclose the iSCSI target name in double quotation marks (" "). You must also enclose the name in either square brackets ([]) or angle brackets (< >). |

Notes

If you enter this command without defining any arguments, this command returns information about all of the iSCSI sessions that are currently running. The following command returns information about all of the current iSCSI sessions:

```
show iscsiSessions
```

To limit the information that is returned, enter a specific iSCSI initiator or a specific iSCSI target. This command then returns information about the session for only the iSCSI initiator or the iSCSI target that you named.

Minimum Firmware Level

7.10

Show Drive

For each drive in the storage array, this command returns the following information:

- The total number of drives
- The type of drive (Fibre Channel, SATA, or SAS)
- Information about the basic drive:
 - The tray location and the slot location
 - The status
 - The capacity
 - The data transfer rate
 - The product ID
 - The firmware level
- Information about the drive channel:
 - The tray location and the slot location
 - The preferred channel
 - The redundant channel
- Hot spare coverage
- Details for each drive

Depending on the size of your storage array, this information can be several pages long. To view an example of the drive information that is returned by the **show drives** command, refer to the "Examples of Information Returned by the Show Commands" topic in "Configuring and Maintaining a Storage Array Using the Command Line Interface." In addition, the drive information is returned for the **show storageArray profile** command.

Syntax

```
show (allDrives
[driveMediaType=(HDD | SSD | unknown | allMedia)] |
[driveType=(fibre | SATA | SAS)]) |
drive [trayID,drawerID,slotID] |
drives [trayID1,drawerID1,slotID1 ... trayIDn,drawerIDn,slotIDn])
summary
```

Parameters

| Parameter | Description |
|----------------|---|
| allDrives | The setting to return information about all of the drives in the storage array. |
| driveMediaType | The type of drive media for which you want to retrieve information. The following values are valid types of drive media: <ul style="list-style-type: none"> ▪ HDD – Use this option when you have hard drives in the drive tray. ▪ SSD – Use this option when you have solid state drives in the drive tray. ▪ unknown – Use this option if you are not sure what types of drive media are in the drive tray. |

| Parameter | Description |
|-----------------|---|
| | <ul style="list-style-type: none"> ▪ allMedia – Use this option when you want to use all types of drive media that are in the drive tray. |
| driveType | <p>The type of drive for which you want to retrieve information. You cannot mix drive types. Valid drive types are :</p> <ul style="list-style-type: none"> ▪ fibred ▪ SATA ▪ SAS <p>If you do not specify a drive type, the command defaults to fibred.</p> |
| drive or drives | <p>The location of the drive for which you want to retrieve information. For high-capacity drive trays, specify the tray ID value, the drawer ID value, and the slot ID value for each drive. For low-capacity drive trays, specify the tray ID value and the slot ID value for each drive. Tray ID values are 0 to 99. Drawer ID values are 1 to 5. Slot ID values are 1 to 32. Enclose the tray ID values, the drawer ID values, and the slot ID values in parentheses.</p> |
| summary | <p>The setting to return the status, the capacity, the data transfer rate, the product ID, and the firmware version for the specified drives.</p> |

Notes

To determine information about the type and location of all of the drives in the storage array, use the `allDrives` parameter.

To determine the information about the Fibre Channel, SATA, or SAS drives in the storage array, use the `driveType` parameter.

To determine the type of drive in a specific location, use the `drive` parameter, and enter the tray ID and the slot ID for the drive.

The `drive` parameter supports both high-capacity drive trays and low-capacity drive trays. A high-capacity drive tray has drawers that hold the drives. The drawers slide out of the drive tray to provide access to the drives. A low-capacity drive tray does not have drawers. For a high-capacity drive tray, you must specify the identifier (ID) of the drive tray, the ID of the drawer, and the ID of the slot in which a drive resides. For a low-capacity drive tray, you need only specify the ID of the drive tray and the ID of the slot in which a drive resides. For a low-capacity drive tray, an alternative method for identifying a location for a drive is to specify the ID of the drive tray, set the ID of the drawer to 0, and specify the ID of the slot in which a drive resides.

Minimum Firmware Level

5.43

7.60 adds the `drawerID` user input and the `driveMediaType` parameter.

Show Drive Channel Statistics

This command shows the cumulative data transfer for the drive channel and error information. If the controller has automatically degraded a drive channel, this command also shows interval statistics. When you use this command, you can show information about one specific drive channel, several drive channels, or all drive channels.

Syntax

```
show (driveChannel [(1 | 2 | 3 | 4 | 5 | 6 | 7 | 8)] |
driveChannels [1 2 3 4 5 6 7 8] |
allDriveChannels) stats
```

Parameters

| Parameter | Description |
|------------------|---|
| driveChannel | The identifier number of a specific drive channel for which you want to show information. Valid drive channel values are 1, 2, 3, 4, 5, 6, 7, or 8. Enclose the drive channel in square brackets ([]). Use this parameter when you want to show the statistics for only one drive channel. |
| driveChannels | The identifier numbers of several drive channels for which you want to show information. Valid drive channel values are 1, 2, 3, 4, 5, 6, 7, or 8. Enclose the drive channels in square brackets ([]) with the drive channel value separated with a space. Use this parameter when you want to show the statistics for more than one drive channel. |
| allDriveChannels | The identifier that selects all of the drive channels. |

Notes

None.

Minimum Firmware Level

6.10

7.15 adds an update to the drive channel identifier.

Show Drive Download Progress

This command returns the status of firmware downloads for the drives that are targeted by the `download drive firmware` command or the `download storageArray driveFirmware` command.

Syntax

```
show allDrives downloadProgress
```

Parameters

None.

Notes

When all of the firmware downloads have successfully completed, this command returns good status. If any firmware downloads fail, this command shows the firmware download status of each drive that was targeted. This command returns the statuses shown in this table.

| Status | Definition |
|------------------|---|
| Successful | The downloads completed without errors. |
| Not Attempted | The downloads did not start. |
| Partial Download | The downloads are in progress. |
| Failed | The downloads completed with errors. |

Minimum Firmware Level

6.10

Show Host Interface Card Diagnostic Status

This command returns the status of running, interrupted, or completed host interface card diagnostics started by the `start hostCard diagnostic` command. If the diagnostics have finished, the entire results of the diagnostic tests are shown. If the diagnostics have not finished, only the results of the tests that are finished are shown. The results of the test are shown on the terminal, or you can write the results to a file.

Syntax

```
show hostCard controller [(a | b)] diagnosticStatus [progressOnly] [file=filename]
```

Parameters

| Parameter | Description |
|------------------|--|
| controller | The controller that has the host interface card on which you are running the diagnostic tests. Valid controller identifiers are <code>a</code> or <code>b</code> , where <code>a</code> is the controller in slot A, and <code>b</code> is the controller in slot B. Enclose the controller identifier in square brackets ([]). If you do not specify a controller, the storage management software returns a syntax error. |
| progressOnly | The <code>progressOnly</code> parameter, shows the progress of the diagnostic test without waiting for the diagnostic tests to completely finish. |
| file | The name of the file that contains the results of the diagnostic tests. This command does not automatically append a file extension to the file name. You must add an extension when you enter the file name. |

Notes

The `progressOnly` parameter is useful for seeing the progress of command scripts that need to sequentially complete operations.

Minimum Firmware Level

7.70 adds the capability for controller host interface card diagnostics.

Show Host Ports

For all of the host ports that are connected to a storage array, this command returns this information:

- The host port identifier
- The host port name
- The host type

Syntax

```
show allHostPorts
```

Parameters

None.

Notes

This command returns HBA host port information similar to this example.

| HOST PORT IDENTIFIER | HOST PORT NAME | HOST TYPE |
|-------------------------|----------------|------------------------------------|
| 12:34:56:54:33:22:22:22 | Jupiter1 | Solaris |
| 12:34:56:78:98:98:88:88 | Pluto1 | Windows 2000/Server 2003 Clustered |
| 54:32:12:34:34:55:65:66 | Undefined | Undefined |

Minimum Firmware Level

5.40

Show Remote Volume Mirroring Volume Candidates

This command returns information about the candidate volumes on a remote storage array that you can use as secondary volumes in a Remote Volume Mirroring configuration.

Syntax

```
show remoteMirror candidates primary="volumeName"  
remoteStorageArrayName="storageArrayName"
```

Parameters

| Parameter | Description |
|------------------------|---|
| primary | The name of the local volume that you want for the primary volume in the remote-mirrored pair. Enclose the primary volume name in double quotation marks (" "). |
| remoteStorageArrayName | The remote storage array that contains possible volumes for a secondary volume. If the remote storage array name has special characters, you must also enclose the remote storage array name in double quotation marks (" "). |

Minimum Firmware Level

5.40

Show Remote Volume Mirroring Volume Synchronization Progress

This command returns the progress of data synchronization between the primary volume and the secondary volume in a Remote Volume Mirroring configuration. This command shows the progress as a percentage of data synchronization that has been completed.

Syntax

```
show remoteMirror (localVolume ["volumeName"] |
localVolumes ["volumeName1" ... "volumeNameN"])
synchronizationProgress
```

Parameter

| Parameter | Description |
|-----------------------------|---|
| localVolume or localVolumes | The name of the primary volume of the remote mirrored pair for which you want to check synchronization progress. Enclose the primary volume name in double quotation marks (" ") inside of square brackets ([]). |

Minimum Firmware Level

5.40

Show Storage Array

This command returns configuration information about the storage array. The parameters return lists of values for the components and features in the storage array. You can enter the command with a single parameter or more than one parameter. If you enter the command without any parameters, the entire storage array profile is shown (which is the same information as if you entered the `profile` parameter).

Syntax

```
show storageArray | autoSupportConfig | profile |
```

batteryAge | connections | defaultHostType | healthStatus |
 hostTypeTable | hotSpareCoverage | features | time |
 volumeDistribution | longRunningOperations | summary

Parameters

| Parameter | Description |
|--------------------|--|
| profile | The parameter to show all of the properties of the logical components and the physical components that comprise the storage array. The information appears in several screens. |
| autoSupportConfig | The parameter to return information about the current state of the operation to automatically collect support data. The following information is returned: <ul style="list-style-type: none"> ▪ Whether the operation is enabled or disabled ▪ The location of the folder where the support data file is located |
| batteryAge | The parameter to show the status, the age of the battery in days, and the number of days until the battery needs to be replaced. |
| connections | The parameter to show a list of where the drive channel ports are located and where the drive channels are connected. |
| defaultHostType | The parameter to show the default host type and the host type index. |
| healthStatus | The parameter to show the health, logical properties, and physical component properties of the storage array. |
| hostTypeTable | The parameter to show a table of all of the host types that are known to the controller. Each row in the table shows a host type index and the platform that the host type index represents. |
| hotSpareCoverage | The parameter to show information about which volumes of the storage array have hot spare coverage and which volumes do not. |
| features | The parameter to show a list of the feature identifiers for all enabled premium features in the storage array. |
| time | The parameter to show the current time to which both controllers in the storage array are set. |
| volumeDistribution | The parameter to show the current controller owner for each volume in the storage array. |

| Parameter | Description |
|-----------------------|--|
| longRunningOperations | <p>The parameter to show the long running operations for each volume group and each volume in the storage array.</p> <p>The longRunningOperation parameter returns this information:</p> <ul style="list-style-type: none"> ▪ Name of the volume group or volume ▪ Long running operation ▪ Status ▪ % complete ▪ Time left |
| summary | The parameter to show a concise list of information about the storage array configuration. |

Notes

The `profile` parameter shows detailed information about the storage array. The information appears on several screens on a display monitor. You might need to increase the size of your display buffer to see all of the information. Because this information is so detailed, you might want to save the output of this parameter to a file. To save the output to a file, run the `show storageArray` command that looks like this example.

```
-c "show storageArray profile;" -o "c:\\folder\\storageArrayProfile.txt"
```

The previous command syntax is for a host that is running a Windows operating system. The actual syntax varies depending on your operating system.

The `profile` parameter also returns information about the power supplies if the storage array has that capability.

*** UNDEFINED CROSS-REF FORMAT [Heading] *** shows the type of information that is returned. When you save the information to a file, you can use the information as a record of your configuration and as an aid during recovery.

The `batteryAge` parameter returns information in this form.

```
Battery status: Optimal
  Age: 1 day(s)
  Days until replacement: 718 day(s)
```

The newer controller trays do not support the `batteryAge` parameter.

The `defaultHostType` parameter returns information in this form.

```
Default host type: Linux (Host type index 6)
```

The `healthStatus` parameter returns information in this form.

```
Storage array health status = optimal.
```

The `hostTypeTable` parameter returns information in this form.

NVSRAM HOST TYPE INDEX DEFINITIONS

| INDEX | AVT | STATUS | TYPE |
|-------------|----------|--------------------------|-------------------------------|
| 0 | Disabled | Windows NT | Non-Clustered (SP5 or higher) |
| 1 (Default) | Disabled | Windows 2000/Server 2003 | Non-Clustered |
| 2 | Disabled | Solaris | |
| 3 | Enabled | HP-UX | |
| 4 | Disabled | AIX | |
| 5 | Disabled | Irix | |
| 6 | Enabled | Linux | |
| 7 | Disabled | Windows NT | Clustered (SP5 or higher) |
| 8 | Disabled | Windows 2000/Server 2003 | Clustered |
| 9 | Enabled | Netware | Non-Failover |
| 10 | Enabled | PTX | |
| 11 | Enabled | Netware | Failover |
| 12 | Enabled | Solaris | (with Veritas DMP) |

The `hotSpareCoverage` parameter returns information in this form.

```
The following volume groups are not protected: 2, 1
Total hot spare drives: 0
  Standby: 0
  In use: 0
```

The `features` parameter returns information in this form.

```
storagePartitionMax
snapshot
remoteMirror
volumeCopy
```

The `time` parameter returns information in this form.

```
Controller in Slot A
Date/Time: Thu Jun 03 14:54:55 MDT 2004
Controller in Slot B
Date/Time: Thu Jun 03 14:54:55 MDT 2004
```

The `longRunningOperations` parameter returns information in this form:

| LOGICAL DEVICES | OPERATION | STATUS | TIME REMAINING |
|-----------------|------------------|---------------|----------------|
| Volume-2 | Volume Disk Copy | 10% COMPLETED | 5 min |

The information fields returned by the `longRunningOperations` parameter have these meanings:

- `NAME` is the name of a volume that is currently in a long running operation. The volume name must have the "Volume" as a prefix.
- `OPERATION` lists the operation being performed on the volume group or volume.
- `% COMPLETE` shows how much of the long running operation has been performed.
- `STATUS` can have one of these meanings:
 - Pending – The long running operation has not started but will start after the current operation is completed.

- In Progress – The long running operation has started and will run until completed or stopped by user request.
- `TIME LEFT` indicates the duration remaining to completing the current long running operation. The time is in an "hours minute" format. If less than an hour remains, only the minutes are shown. If less than a minute remains, the message "less than a minute" is shown.

The `volumeDistribution` parameter returns information in this form.

```

volume name: 10
    Current owner is controller in slot: A
volume name: CTL 0 Mirror Repository
    Current owner is controller in slot: A
volume name: Mirror Repository 1
    Current owner is controller in slot:A
volume name: 20
    Current owner is controller in slot:A
volume name: JCG_Remote_MirrorMenuTests
    Current owner is controller in slot:A

```

Minimum Firmware Level

5.00 adds the `defaultHostType` parameter.

5.43 adds the `summary` parameter.

6.10 adds the `volumeDistribution` parameter.

6.14 adds the `connections` parameter.

7.10 adds the `autoSupportConfig` parameter.

7.77 adds the `longRunningOperations` parameter.

Show Storage Array Auto Configure

This command shows the default auto-configuration that the storage array creates if you run the **`autoConfigure storageArray`** command. If you want to determine whether the storage array can support specific properties, enter the parameter for the properties when you run this command. You do not need to enter any parameters for this command to return configuration information.

Syntax

```

show storageArray autoConfiguration
[driveType=(fibre | SATA | SAS)
driveMediaType=(HDD | SSD | unknown | allMedia)
raidLevel=(0 | 1 | 3 | 5 | 6)
volumeGroupWidth=numberOfDrives
volumeGroupCount=numberOfVolumeGroups
volumesPerGroupCount=numberOfVolumesPerGroup
hotSpareCount=numberOfHotspares
segmentSize=segmentSizeValue
cacheReadPrefetch=(TRUE | FALSE)
securityType=(none | capable | enabled)]

```

Parameters

| Parameter | Description |
|----------------------|--|
| driveType | <p>The type of drives that you want to use for the storage array.</p> <p>The <code>driveType</code> parameter is not required if only one type of drive is in the storage array. You must use this parameter when you have more than one type of drive in your storage array.</p> <p>Valid drive types are :</p> <ul style="list-style-type: none"> ▪ fibre ▪ SATA ▪ SAS <p>If you do not specify a drive type, the command defaults to fibre.</p> |
| driveMediaType | <p>The type of drive media that you want to use for the mirror repository volume group. Valid drive media are these:</p> <ul style="list-style-type: none"> ▪ HDD – Use this option when you have hard drives in the drive tray. ▪ SSD – Use this option when you have solid state drives in the drive tray. ▪ unknown – Use if you are not sure what types of drive media are in the drive tray. ▪ allMedia – Use this option when you want to use all types of drive media that are in the drive tray. <p>Use this parameter when you use the <code>repositoryDriveCount</code> parameter.</p> <p>You must use this parameter when you have more than one type of drive media in your storage array.</p> |
| raidLevel | <p>The RAID level of the volume group that contains the drives in the storage array. Valid RAID levels are 0, 1, 3, 5, or 6.</p> |
| volumeGroupWidth | <p>The number of drives in a volume group in the storage array, which depends on the capacity of the drives.</p> <p>Use integer values.</p> |
| volumeGroupCount | <p>The number of volume groups in the storage array.</p> <p>Use integer values.</p> |
| volumesPerGroupCount | <p>The number of equal-capacity volumes per volume group. Use integer values.</p> |
| hotSpareCount | <p>The number of hot spares that you want in the storage array. Use integer values.</p> |

| Parameter | Description |
|-------------------|--|
| segmentSize | The amount of data (in KB) that the controller writes on a single drive in a volume before writing data on the next drive. Valid values are 8, 16, 32, 64, 128, 256, or 512 . |
| cacheReadPrefetch | The setting to turn on or turn off cache read prefetch. To turn off cache read prefetch, set this parameter to FALSE . To turn on cache read prefetch, set this parameter to TRUE . |
| securityType | The setting to specify the security level when creating the volume groups and all associated volumes. These settings are valid: <ul style="list-style-type: none"> ▪ none – The volume group and volumes are not secure. ▪ capable – The volume group and volumes are capable of having security set, but security has not been enabled. ▪ enabled – The volume group and volumes have security enabled. |

Notes

If you do not specify any properties, this command returns the RAID Level 5 candidates for each drive type. If RAID Level 5 candidates are not available, this command returns candidates for RAID Level 6, RAID Level 3, RAID Level 1, or RAID Level 0. When you specify auto configuration properties, the controllers validate that the firmware can support the properties.

Drives and Volume Group

A volume group is a set of drives that are logically grouped together by the controllers in the storage array. The number of drives in a volume group is a limitation of the RAID level and the controller firmware. When you create a volume group, follow these guidelines:

- Beginning with firmware version 7.10, you can create an empty volume group so that you can reserve the capacity for later use.
- You cannot mix drive types, such as SAS and Fibre Channel, within a single volume group.
- The maximum number of drives in a volume group depends on these conditions:
 - The type of controller
 - The RAID level
- RAID levels include: 0, 1, 10, 3, 5, and 6.
 - In a CDE3992 or a CDE3994 storage array, a volume group with RAID level 0 and a volume group with RAID level 10 can have a maximum of 112 drives.
 - In a CE6998 storage array, a volume group with RAID level 0 and a volume group with RAID level 10 can have a maximum of 224 drives.
 - A volume group with RAID level 3, RAID level 5, or RAID level 6 cannot have more than 30 drives.
 - A volume group with RAID level 6 must have a minimum of five drives.

- If a volume group with RAID level 1 has four or more drives, the storage management software automatically converts the volume group to a RAID level 10, which is RAID level 1 + RAID level 0.
- If a volume group contains drives that have different capacities, the overall capacity of the volume group is based on the smallest capacity drive.
- To enable tray loss protection, you must create a volume group that uses drives located in at least three drive trays.

Hot Spares

Hot spare drives can replace any failed drive in the storage array. A hot spare drive must have capacity greater than or equal to any drive that can fail. If a hot spare drive is smaller than a failed drive, you cannot use the hot spare drive to rebuild the data from the failed drive. Hot spare drives are available only for RAID Level 1, RAID Level 3, RAID Level 5, or RAID Level 6.

Segment Size

The size of a segment determines how many data blocks that the controller writes on a single drive in a volume before writing data on the next drive. Each data block stores 512 bytes of data. A data block is the smallest unit of storage. The size of a segment determines how many data blocks that it contains. For example, an 8-KB segment holds 16 data blocks. A 64-KB segment holds 128 data blocks.

When you enter a value for the segment size, the value is checked against the supported values that are provided by the controller at run time. If the value that you entered is not valid, the controller returns a list of valid values. Using a single drive for a single request leaves other drives available to simultaneously service other requests. If the volume is in an environment where a single user is transferring large units of data (such as multimedia), performance is maximized when a single data transfer request is serviced with a single data stripe. (A data stripe is the segment size that is multiplied by the number of drives in the volume group that are used for data transfers.) In this case, multiple drives are used for the same request, but each drive is accessed only once.

For optimal performance in a multiuser database or file system storage environment, set your segment size to minimize the number of drives that are required to satisfy a data transfer request.

Cache Read Prefetch

Cache read prefetch lets the controller copy additional data blocks into cache while the controller reads and copies data blocks that are requested by the host from the drive into cache. This action increases the chance that a future request for data can be fulfilled from cache. Cache read prefetch is important for multimedia applications that use sequential data transfers. The configuration settings for the storage array that you use determine the number of additional data blocks that the controller reads into cache. Valid values for the `cacheReadPrefetch` parameter are **TRUE** or **FALSE**.

Minimum Firmware Level

6.10

7.10 adds RAID Level 6 capability and removes hot spare limits.

Show Storage Array Host Topology

This command returns the storage partition topology, the host type labels, and the host type index for the host storage array.

Syntax

```
show storageArray hostTopology
```

Parameters

None.

Notes

This command returns the host topology information similar to this example.

TOPOLOGY DEFINITIONS

DEFAULT GROUP

Default type: Windows 2000/Server 2003 Non-Clustered

Host Group: scott

Host: scott1

Host Port: 28:37:48:55:55:55:55:55

Alias: scott11

Type: Windows 2000/Server 2003 Clustered

Host: scott2

Host Port: 98:77:66:55:44:33:21:23

Alias: scott21

Type: Windows 2000/Server 2003 Clustered

Host: Bill

Host Port: 12:34:55:67:89:88:88:88

Alias: Bill1

Type: Windows 2000/Server 2003 Non-Clustered

NVSRAM HOST TYPE INDEX DEFINITIONS

| INDEX | AVT STATUS | TYPE |
|-------------|------------|--|
| 0 | Disabled | Windows NT Non-Clustered (SP5 or higher) |
| 1 (Default) | Disabled | Windows 2000/Server 2003 Non-Clustered |
| 2 | Disabled | Solaris |
| 3 | Enabled | HP-UX |
| 4 | Disabled | AIX |
| 5 | Disabled | Irix |
| 6 | Enabled | Linux |
| 7 | Disabled | Windows NT Clustered (SP5 or higher) |
| 8 | Disabled | Windows 2000/Server 2003 Clustered |
| 9 | Enabled | Netware Non-Failover |
| 10 | Enabled | PTX |
| 11 | Enabled | Netware Failover |
| 12 | Enabled | Solaris (with Veritas DMP) |

Minimum Firmware Level

5.20

Show Storage Array LUN Mappings

This command returns information from the storage array profile about the logical unit number (LUN) mappings in the storage array. Default group LUN mappings are always shown. If you run this command without any parameters, this command returns all of the LUN mappings.

Syntax

```
show storageArray lunMappings [host ["hostName"] |
hostgroup ["hostGroupName"]]
```

Parameters

| Parameter | Description |
|-----------|--|
| host | The name of a specific host for which you want to see the LUN mappings. Enclose the host name in double quotation marks (") inside of square brackets ([]). |
| hostGroup | The name of a specific host group for which you want to see the LUN mappings. Enclose the host group name in double quotation marks (") inside of square brackets ([]). |

Notes

This command returns host topology information similar to this example.

```
MAPPINGS (Storage Partitioning - Enabled (0 of 16 used))
VOLUME NAME  LUN  CONTROLLER  ACCESSIBLE BY  VOLUME STATUS
Access Volume 7  A,B          Default Group  Optimal
21            21  B           Default Group  Optimal
22            22  B           Default Group  Optimal
```

Minimum Firmware Level

6.10

Show Storage Array Negotiation Defaults

This statement returns information about connection-level settings that are subject to initiator-target negotiation.

Syntax

```
show storageArray iscsiNegotiationDefaults
```

Parameters

None.

Notes

Information returned includes RAID controller tray default settings (that is, those settings that are the starting point for negotiation) and the current active settings.

Minimum Firmware Level

7.10

Show Storage Array Remote Status Notification

This command shows the proxy configuration settings for the remote status notification feature that were defined by the `set remoteStatusNotification proxyConfig` command. The remote status proxy configuration settings apply to all of the storage arrays managed by the storage management station. The storage arrays must be capable of supporting the storage array profile and the support bundle. The proxy configuration settings are saved in the `devmgr.datadir\monitor\EMRSstate\EMRSRuntimeConfig.xml` file on the storage management station.

Syntax

```
show remoteStatusNotification proxyConfig
```

Parameter

None.

Minimum Firmware Level

7.70

Show Storage Array Unconfigured iSCSI Initiators

This command returns a list of initiators that have been detected by the storage array but are not yet configured into the storage array topology.

Syntax

```
show storageArray unconfiguredIscsiInitiators
```

Parameters

None.

Minimum Firmware Level

7.10

Show Storage Array Unreadable Sectors

This command returns a table of the addresses of all of the sectors in the storage array that cannot be read. The table is organized with column headings for the following information:

1. Volume user label
2. Logical unit number (LUN)
3. Accessible by (host or host group)
4. Date/time
5. Volume-relative logical block address (hexadecimal format – 0xnxxxxxxxx)
6. Drive location (tray t, slot s)
7. Drive-relative logical block address (hexadecimal format – 0xnxxxxxxxx)
8. Failure type

The data is sorted first by the volume user label and second by the logical block address (LBA). Each entry in the table corresponds to a single sector.

Syntax

```
show storageArray unreadableSectors
```

Parameters

None.

Minimum Firmware Level

6.10

Show String

This command shows a string of text from a script file. This command is similar to the `echo` command in MS-DOS and UNIX.

Syntax

```
show "textString"
```

Parameters

None.

Notes

Enclose the string in double quotation marks (" ").

Minimum Firmware Level

6.10

Show Volume

For the volumes in a storage array, this command returns the following information:

- The number of volumes
- The name
- The status
- The capacity
- The RAID level
- The volume group where the volume is located
- Details:
 - The volume ID
 - The subsystem ID
 - The drive type (Fibre Channel, SATA, or SAS)
 - Tray loss protection

- The preferred owner
- The current owner
- The segment size
- The modification priority
- The read cache status (enabled or disabled)
- The write cache status (enabled or disabled)
- The write cache without batteries status (enabled or disabled)
- The write cache with mirror status (enabled or disabled)
- The flush write cache after time
- The cache read prefetch setting (TRUE or FALSE)
- The enable background media scan status (enabled or disabled)
- The media scan with redundancy check status (enabled or disabled)
- The snapshot repository volumes
- The mirror repository volumes
- The snapshot volumes
- The snapshot copies

To view an example of the information returned by this command, refer to the topic "Examples of Information Returned by the Show Commands" in *Configuring and Maintaining a Storage Array Using the Command Line Interface*.

Syntax

```
show (allVolumes | volume [volumeName] |
volumes [volumeName1 ... volumeNameN]) summary
```

Parameters

| Parameter | Description |
|-------------------|--|
| allVolumes | The setting to return information about all of the volumes in the storage array. |
| volume or volumes | The name of the specific volume for which you are retrieving information. You can enter more than one volume name. Enclose the volume name in square brackets ([]). If the volume name has special characters, you also must enclose the volume name in double quotation marks (" "). |
| summary | The setting to return a concise list of information about the volumes. |

Notes

For snapshot volume copies, the **show volume** command returns information about the schedules for the snapshot volume copies. The schedule information is in this form:

```
Schedule State: "Active" | "Disabled" | "Completed"
Last Run Time: <mm/dd/yyyy> <hh:mm a.m. | p.m.>
Next Run Time: <mm/dd/yyyy> <hh:mm a.m. | p.m.>
Start Date: <mm/dd/yyyy>End Date: <mm/dd/yyyy> | "No End Date"
```

Days of Week: <Sunday - Saturday>, <Sunday - Saturday>, ...
 Times for snapshot recreate: <hh:mm a.m. | p.m.>, <hh:mm a.m. | p.m.>

Minimum Firmware Level

5.00

5.43 adds the `summary` parameter.

7.77 adds the schedule information for the snapshot volume copies.

Show Volume Action Progress



NOTE With firmware version 7.77, the `show volume actionProgress` command is deprecated. Replace this command with `show storageArray longRunningOperations`.

For a long-running operation that is currently running on a volume, this command returns information about the volume action and amount of the long-running operation that is completed. The amount of the long-running operation that is completed is shown as a percentage (for example, 25 means that 25 percent of the long-running operation is completed).

Syntax

```
show volume ["volumeName"] actionProgress
```

Parameter

| Parameter | Description |
|-----------|--|
| volume | The name of the volume that is running the long-running operation. Enclose the volume name in double quotation marks (" ") inside of square brackets ([]). |

Minimum Firmware Level

5.43

7.77 deprecates this command.

Show Volume Copy

This command returns this information about volume copy operations:

- The copy status
- The start time stamp
- The completion time stamp
- The copy priority
- The source volume World Wide Identifier (WWID) or the target volume WWID
- The target volume Read-Only attribute setting

You can retrieve information about a specific volume copy pair or all of the volume copy pairs in the storage array.

Syntax

```
show volumeCopy (allVolumes | source ["sourceName"] |
target ["targetName"])
```

Parameters

| Parameter | Description |
|------------|--|
| allVolumes | The setting to return information about volume copy operations for all of the volume copy pairs. |
| source | The name of the source volume about which you want to retrieve information. Enclose the source volume name in double quotation marks (" ") inside of square brackets ([]). |
| target | The name of the target volume about which you want to retrieve information. Enclose the target volume name in double quotation marks (" ") inside of square brackets ([]). |

Minimum Firmware Level

5.40

Show Volume Copy Source Candidates

This command returns information about the candidate volumes that you can use as the source for a volume copy operation.

Syntax

```
show volumeCopy sourceCandidates
```

Parameters

None.

Notes

This command returns volume copy source information as shown in this example.

```
Volume Name: finance
  Capacity: 4.0 GB
  Volume Group: 1
Volume Name: engineering
  Capacity: 4.0 GB
  Volume Group: 2
```

Minimum Firmware Level

6.10

Show Volume Copy Target Candidates

This command returns information about the candidate volumes that you can use as the target for a volume copy operation.

Syntax

```
show volumeCopy source ["sourceName"] targetCandidates
```

Parameter

| Parameter | Description |
|-----------|--|
| source | The name of the source volume for which you are trying to find a candidate target volume. Enclose the source volume name in double quotation marks (" ") inside of square brackets ([]). |

Minimum Firmware Level

6.10

Show Volume Group

This command returns this information about a volume group:

- The status (Online or Offline)
- The drive type (Fibre Channel, SATA, or SAS)
- Tray loss protection (yes or no)
- The current owner (the controller in slot A or the controller in slot B)
- The associated volumes and free capacity
- The associated drives

Syntax

```
show volumeGroup [volumeGroupName]
```

Parameter

| Parameter | Description |
|-------------|---|
| volumeGroup | The alphanumeric identifier of the volume group (including - and _) for which you want to show information. Enclose the volume group identifier in square brackets ([]). |

Notes

This command returns volume group information as shown in this example:

```
Volume Group 1 (RAID 5)
  Status: Online
  Drive type: Fibre Channel
  Tray loss protection: No
```



```

Current owner: Controller in slot A
Associated volumes and free capacities:
  1 (1 GB), 1R1 (0.2 GB), Free Capacity (134.533 GB)
Associated drives (in piece order):
  Drive at Tray 1, Slot 14
  Drive at Tray 1, Slot 13
  Drive at Tray 1, Slot 12

```

Minimum Firmware Level

6.10

Show Volume Group Export Dependencies

This command shows a list of dependencies for the drives in a volume group that you want to move from one storage array to a second storage array.

Syntax

```
show volumeGroup [volumeGroupName] exportDependencies
```

Parameter

| Parameter | Description |
|-------------|---|
| volumeGroup | The alphanumeric identifier (including - and _) of the volume group for which you want to show export dependencies. Enclose the volume group identifier in square brackets ([]). |

Notes

This command spins up the drives in a volume group, reads the DACstore, and shows a list of import dependencies for the volume group. The volume group must be in an Exported state or a Forced state.

Minimum Firmware Level

7.10

Show Volume Group Import Dependencies

This command shows a list of dependencies for the drives in a volume group that you want to move from one storage array to a second storage array.

Syntax

```
show volumeGroup [volumeGroupName] importDependencies
[cancelImport=(TRUE | FALSE)]
```

Parameters

| Parameter | Description |
|--------------|---|
| volumeGroup | The alphanumeric identifier (including - and _) of the volume group for which you want to show import dependencies. Enclose the volume group identifier in square brackets ([]). |
| cancelImport | The setting to spin the drives back down after the volume group dependencies have been read. To spin down the drives, set this parameter to TRUE . To let the drives stay spinning, set this parameter to FALSE . |

Notes

This command returns the dependencies of a specific volume group, which must be in an Exported state or a Forced state. If a decision is made to retain the listed dependencies, then the `cancelImport` parameter can be enforced to spin the drives back down.

You must run the `show volumeGroup importDependencies` command before you run the `start volumeGroup import` command.

Minimum Firmware Level

7.10

Show Volume Performance Statistics

This command returns information about the performance of the volumes in a storage array.

Syntax

```
show (allVolumes | volume [volumeName]
volumes [volumeName1 ... volumeNameN]) performanceStats
```

Parameters

| Parameter | Description |
|-------------------|---|
| allVolumes | The setting to return performance statistics about all of the volumes in the storage array. |
| volume or volumes | The name of the specific volume for which you are retrieving performance statistics. You can enter more than one volume name. Enclose the volume name in square brackets ([]). If the volume name has special characters, you also must enclose the volume name in double quotation marks (" "). |

Notes

Before you run the `show volume performanceStat` command, run the `set session performanceMonitorInterval` command and the `set session performanceMonitorIterations` command to define how often you collect the statistics.

The **show volume** command returns volume performance statistics as shown in this example:

```
Performance Monitor Statistics for Storage Array: ausctrl9
Date/Time: 2/19/09 4:03:09 PM
Polling Interval in seconds: 10
Devices, Total, Read, Cache, Hit, Current, Maximum,
  Current, Maximum, IOs, Percentage, Percentage,
  KB/second, KB/second, IO/second, IO/second
Capture Iteration: 1
Date/Time: 2/19/04 4:03:09 PM
Controller in slot A,0.0,0.0,0.0,0.0,0.0,0.0,0.0,
Volume 1,0.0,0.0,0.0,0.0,0.0,0.0,0.0,
Volume 2,0.0,0.0,0.0,0.0,0.0,0.0,0.0,
Volume 3,0.0,0.0,0.0,0.0,0.0,0.0,0.0,
Storage Array totals,0.0,0.0,0.0,0.0,0.0,0.0,0.0,
```

Minimum Firmware Level

6.10

Show Volume Reservations

This command returns information about the volumes that have persistent reservations.

Syntax

```
show (allVolumes | volume [volumeName] |
volumes [volumeName1 ... volumeNameN]) reservations
```

Parameters

| Parameter | Description |
|-------------------|---|
| allVolumes | The setting to return persistent reservation information about all of the volumes in the storage array. |
| volume or volumes | The name of the specific volume for which you are retrieving persistent reservation information. You can enter more than one volume name. Enclose the volume name in square brackets ([]). If the volume name has special characters, you also must enclose the volume name in double quotation marks (" "). |

Minimum Firmware Level

5.40

Start Cache Backup Device Diagnostic



ATTENTION Before you run this diagnostic test, make sure that the cache backup device has a status of Optimal.

This command runs diagnostic tests to evaluate the functionality of the device that you use to backup the data in the cache if you lose power to the controller. The diagnostic tests are specific to the backup device that is in the controller. Before you run these tests, make these changes to the controller that has the backup device on which you want to run diagnostics:

- Place the controller into service mode (use the `set controller [(a | b)] availability=serviceMode` command).
- Attach the management client directly to the controller through the management Ethernet port.

 **NOTE** In a dual-controller configuration, you must run these diagnostic tests through the controller that you want to evaluate. You cannot run these diagnostic tests through the partner controller.

Syntax

```
start cacheBackupDevice [(1 | n | all)]
controller [(a | b)]
diagnostic diagnosticType=(basic | extended)
[extendedTestID=(writePatterns | random)]
```

Parameters

| Parameter | Description |
|-------------------|---|
| cacheBackupDevice | <p>The identifier for the cache backup device on which you want to run the diagnostic tests. Valid cache backup device identifiers are 1, 2, 3, 4 or a11.</p> <ul style="list-style-type: none"> ▪ 1 for USB1 on the controller circuit board ▪ 2 for USB2 on the controller circuit board ▪ 3 for USB3 on the controller circuit board ▪ 4 for USB4 on the controller circuit board ▪ a11 for all of the USBs on the controller circuit board <p>NOTE – If you have only one cache backup device, the a11 identifier does not work. Enclose the identifier for the cache backup device in square brackets ([]).</p> |
| controller | <p>The controller that has the cache backup device on which you want to run the diagnostic tests. Valid controller identifiers are a or b, where a is the controller in slot A, and b is the controller in slot B. Enclose the controller identifier in square brackets ([]). If you do not specify a controller, the storage management software returns a syntax error.</p> |
| diagnosticType | <p>The level of diagnostic testing that you want to run on the cache backup device. You can run one of these levels of testing:</p> |

| Parameter | Description |
|----------------|--|
| | <p>basic – This option validates the basic operation of the ability of the cache backup device to store cache data. This option determines these capabilities of the cache backup device:</p> <ul style="list-style-type: none"> ▪ Whether the cache backup device is write protected or the cache can write data to the device. ▪ If the cache backup device is approaching its write cycle limit. <p>extended – This option enables you to run more comprehensive diagnostic tests on the host interface card.</p> |
| extendedTestID | <p>This parameter selects the extended test option that you want to run.</p> <p>If you choose the <code>extended</code> parameter, you also must also use the <code>extendedTestID</code> parameter and one of the extended test options.</p> |

| Extended Test Option | Description |
|----------------------|--|
| writePatterns | This option writes a predefined pattern of data in blocks to the entire cache backup device. Each block that was written is then read back, and the data is verified for integrity and accuracy. |
| random | This option writes a random pattern to each flash block in the cache backup device. |

Notes

- When an unexpected power loss occurs, cache memory can have data that has not been written to the drives. This data must be preserved so that it can be written to the drives when power is restored. The contents of the cache memory are backed up to a persistent storage device, such as a USB flash drive, a SATA drive, or a solid state device (SSD).
- The total storage capacity of the flash drives must be equal to the total cache memory, considering that all storage space in a flash drive is not always usable. For example, in a 1-GB flash drive, approximately 968 MB is usable. Also, in some flash drives, the Cyclic Redundancy Check (CRC) needs to be stored along with the data. Because the metadata region is persisted in these flash drives, the storage capacity for the flash drives must be greater than the size of the cache memory.
- You can run the diagnostic test on only one controller in the storage array at any one time.

Minimum Firmware Level

7.60 adds the capability for cache backup device diagnostics.

Start Cache Memory Diagnostic

This command runs extended diagnostic tests to evaluate the functionality of the cache memory in a controller. Before you run these tests, you must make these changes to the controller on which you want to run diagnostics:

- Place the controller into Service mode (use the `set controller [(a | b)] availability=serviceMode` command).
- Attach the management client directly to the controller through the management Ethernet port.

 **NOTE** In a dual controller configuration, you must run these diagnostic tests through the controller that you want to evaluate. You cannot run these diagnostic tests through the partner controller.

Syntax

```
start cacheMemory controller [(a | b)] diagnostic
diagnosticType=(basic | extended)
[extendedTestID=(marchC | patterns | psuedoRndm| DMACopy)]
```

Parameters

| Parameter | Description |
|----------------|---|
| controller | The controller that has the cache memory on which you want to run the diagnostic tests. Valid controller identifiers are a or b , where a is the controller in slot A, and b is the controller in slot B. Enclose the controller identifier in square brackets ([]). If you do not specify a controller, the storage management software returns a syntax error. |
| diagnosticType | The level of diagnostic testing that you want to run on the host interface card. You can run one of these levels of testing: basic – This option validates the ability of the cache memory to address and access data. extended – This option enables you to run more comprehensive diagnostic tests on the host interface card. |
| extendedTestID | This parameter selects the extended test option that you want to run. If you choose the <code>extended</code> parameter, you also must use the <code>extendedTestID</code> parameter and one of the extended test options. |

| Extended Test Option | Description |
|----------------------|--|
| marchC | This option performs a March C test on specific regions of the Reconfigurable Processor Assembly (RPA) memory. This option tests for only one set of inverse patterns. |

| Extended Test Option | Description |
|----------------------|---|
| patterns | This option performs a word pattern test where the test sequence proceeds with a series of read/write operations for all locations in the specified memory region. The test uses a set of special patterns. The test writes and verifies several patterns at 32-bit widths. |
| pseudoRndm | This option generates a non-repetitive pattern for double word length, writes the pattern to the entire region, and reads back the pattern for verification. |
| DMAcopy | This option tests the capability of Direct Memory Access (DMA) copy operations across regions in the cache memory. This options uses the RPA hardware capabilities to move the data from one region to another region. |

Notes

- You can run the diagnostic test on only one controller in the storage array at any one time.

Minimum Firmware Level

7.60 adds the capability for cache memory diagnostics.

Start Configuration Database Diagnostic

This command starts a diagnostic test to validate the configuration database in the controller firmware.

Syntax

```
start storageArray configDbDiagnostic
```

Parameters

None.

Notes

Upon completion of the diagnostic test, the controller firmware returns one of these results:

- Diagnosis completed without errors. No ZIP file created.
- Diagnosis completed with errors. Refer to the ZIP file created at:

```
...\Install_dir\data\FirmwareUpgradeReports\timestamp_buildNo.zip
```

If the diagnostic test detects an inconsistency in the configuration database, the controller firmware performs these actions:

- Returns a description of the inconsistency
- Saves a ZIP file containing raw binary data

The controller firmware saves the ZIP file to this location:

```
... \Install_dir\data\FirmwareUpgradeReports\timestamp_buildNo.zip
```

You can use the binary data to help determine the cause of the problem, or you can send the file containing the binary data to a Customer and Technical Support representative.

To stop the database configuration diagnostic test, use the `stop storageArray configDbDiagnostic` command.

In addition, you can start the database configuration diagnostic test through the storage management software GUI; however, you cannot stop the database configuration diagnostic test through the storage management software GUI. If you want to stop a running diagnostic test, you must use the `stop storageArray configDbDiagnostic` command.

Minimum Firmware Level

7.75

Start Controller Diagnostic

This command runs diagnostic tests to evaluate the functionality of the controller card. Before you run these tests, you must make these changes to the controller on which you want to run diagnostics:

- Place the controller into Service Mode (use the `set controller [(a | b)] availability=serviceMode` command).
- Attach the management client directly to the controller through the management Ethernet port.



NOTE In a dual controller configuration, you must run these diagnostic tests through the controller that you want to evaluate. You cannot run these diagnostic tests through the partner controller.

Syntax

```
start controller [(a | b)] diagnostic diagnosticType=(basic | extended)
[extendedTestID=(SRAM | FIFO | dataCopy | RAID5Parity | RAID6Parity)]
```

Parameters

| Parameter | Description |
|-------------------------|---|
| <code>controller</code> | The controller on which you want to run the diagnostic tests. Valid controller identifiers are a or b , where a is the controller in slot A, and b is the controller in slot B. Enclose the controller identifier in square brackets ([]). If you do not specify a controller, the storage management software returns a syntax error. |
| <code>diagnostic</code> | The level of diagnostic testing that you want to run on the host interface card. You can run one of these levels of testing: <code>basic</code> – This option validates the ability of the base controller to address and access data. |

| Parameter | Description |
|-----------------------------|---|
| | <code>extended</code> – This option enables you to run more comprehensive diagnostic tests on the base controller card. |
| <code>extendedTestID</code> | This parameter selects the extended test option that you want to run. If you choose the <code>extended</code> parameter, you must also use the <code>extendedTestID</code> parameter and one of the extended test options. |

| Extended Test Option | Description |
|--------------------------|---|
| <code>SRAM</code> | This option tests for address, data, and data retention. The address test attempts to write to specific address offsets. The data test attempts to write several data patterns to the address offsets. The data retention test attempts to write a data pattern and then read the data pattern back after a delay. The purpose of the <code>SRAM</code> option is to find memory parity or error correcting code (ECC) errors. |
| <code>FIFO</code> | This option tests the active processor chip (APC) first in, first out (FIFO) data transmission of the Zip chip. The APC FIFO channels are tested concurrently by writing and verifying different patterns to each channel. |
| <code>dataCopy</code> | This option tests the ability of the Zip chip to support data copy operations that can copy data from one area of the Zip SDRAM to another area of the Zip SDRAM. This test is performed on any available section of the Zip chip that is not busy. |
| <code>RAID5Parity</code> | This option tests the ability of the Zip APC to generate and verify RAID 5 parity data. Data buffers are set up in processor memory and parity is generated in processor memory. Some data buffers are set up in parallel architecture (RPA) memory and parity is generated for the data within the RPA memory. The parity that is generated within processor memory is then compared with the parity in the Zip APC. |
| <code>RAID6Parity</code> | This option tests the ability of the Zip APC to generate and verify RAID 6 parity data. Data buffers are set up in processor memory and parity is generated in processor memory. Some data buffers are set up in redundant parallel architecture (RPA) memory and parity is generated for the data within the RPA memory. The parity that is generated within processor memory is then compared with the parity in the Zip APC. |

Notes

You can run the diagnostic test on only one controller in the storage array at any one time.

Minimum Firmware Level

7.60 adds the capability for controller card diagnostics.

Start Controller Trace

This command starts an operation that saves debug trace information to a compressed file. The debug trace information can be used by a Customer and Technical Support representative to help analyze how well a storage array is running.

Syntax

```
start controller [(a | b | both)] trace
dataType=(current | flushed | currentFlushed | all)
[forceFlush=(TRUE | FALSE)]
```

Parameters

| Parameter | Description |
|------------|---|
| controller | The controller for which you want to collect the trace debug information. Valid controller identifiers are a or b , where a is the controller in slot A, and b is the controller in slot B. You can also simultaneously collect debug for both controllers by entering both . Enclose the controller identifier in square brackets ([]). If you do not specify a controller, the storage management software returns a syntax error. |
| dataType | The type of data that you want to collect: <ul style="list-style-type: none"> ▪ current – Retrieves the current DQ traces ▪ flushed – Retrieves all flushed DQ traces ▪ currentFlushed – Retrieves both the current DQ trace and the flushed DQ trace ▪ all – Retrieves the current DQ trace, flushed DQ trace, and all platform DQ traces <p>NOTE – If dataType=flushed and forceFlush=True, an error message is returned indicating that only active traces can be flushed to the buffer on retrieval.</p> |
| forceFlush | The setting to move the DQ information in the current buffer to the flushed buffer when the DQ trace information defined by the dataType parameter is retrieved. To enable force flush, set this parameter to TRUE . To disable force flush, set this parameter to FALSE . |

| Parameter | Description |
|-------------------|--|
| | NOTE – If <code>dataType=flushed</code> and <code>forceFlush=True</code> , an error message is returned indicating that only active traces can be flushed to the buffer on retrieval. |
| <code>file</code> | The file path and the file name to which you want to save the DQ trace information. Refer to the Notes section for information about naming the files. |

Notes

The DQ trace information is written to a compressed file with an extension of .zip. The file name is a combination of a user-defined file name and the storage array identifier (SAID). A constant of "dq" is also added to the file name. The complete file name has this form:

```
user_defined_file_name-SAID-dq.zip
```

The compressed file contains the information listed in this table.

| File Name | Directory | Comments |
|---|---------------------|---|
| <code>user_provided_file_name-SAID-A.dq</code> | SAID/ timestamp/ | The DQ trace data retrieved from controller A. |
| <code>user_provided_file_name-SAID-B.dq</code> | SAID/ timestamp/ | The DQ trace data retrieved from controller B. |
| <code>user_provided_file_name-SAID-trace_description.xml</code> | SAID/ timestamp/ | The description file in an xml format that describes the DQ file attributes for future data mining. |

Minimum Firmware Level

7.75

Start Drive Channel Fault Isolation Diagnostics

This command runs the drive channel fault isolation diagnostics and stores the results.

Syntax

```
start driveChannel [(1 | 2 | 3 | 4 | 5 | 6 | 7 | 8)]
controller [(a | b)] faultDiagnostics
(testDevices=[all | controller=(a | b) |
esms=[trayID1 (left | right), ... , trayIDn (left | right)] |
drives=[trayID1, slotID1, ... , trayIDn, slotIDn]] |
dataPattern=(fixed | pseudoRandom) |
patternNumber=[(0xhexadecimal | number)] |
maxErrorCount=integer |
testIterations=integer |
timeout=timeInterval)
```

Parameters

| Parameter | Description |
|-----------------------------|---|
| <code>driveChannel</code> | The identifier number of the drive channel that you want to locate. Valid values for the identifier number for the drive channel are 1, 2, 3, 4, 5, 6, 7, or 8. Enclose the drive channel identifier number in square brackets ([]). |
| <code>controller</code> | The identifier letter of the controller that you want to test. Valid controller identifier values are a or b , where a is the controller in slot A, and b is the controller in slot B. |
| <code>testDevices</code> | The identifiers of the devices (controllers, environmental services monitor [ESMs], or drives) that you want to test. You can specify a11 or enter the specific identifiers for the devices that you want to diagnose. |
| <code>dataPattern</code> | The method of repeatability that you want to test. |
| <code>patternNumber</code> | The hexadecimal data pattern that you want to use to run the test. This number can be any hexadecimal number between 0000 to FFFF . You must place 0x in front to indicate a hexadecimal number. |
| <code>maxErrorCount</code> | The number of errors that you want to accept before terminating the test. |
| <code>testIterations</code> | The number of times that you want to repeat the test. |
| <code>timeout</code> | The length of time in minutes that you want to run the test. |

Notes

Use the `save driveChannel faultDiagnostics` command and the `stop driveChannel faultDiagnostics` command with the `start driveChannel faultDiagnostics` command. These commands are needed to save diagnostic test results to a file and to stop the diagnostic test.

Examples of valid `patternNumber` entries are **0xA5A5**, **0x3C3C**, **8787**, and **1234**.

You can also stop this command at any time by pressing **Ctrl+C**.

Minimum Firmware Level

7.15

Start Drive Channel Locate

This command identifies the drive trays that are connected to a specific drive channel by turning on the indicator lights for the drive tray that is connected to the drive channel. (Use the `stop driveChannel locate` command to turn off the indicator lights on the drive tray.)

Syntax

```
start driveChannel [(1 | 2 | 3 | 4 | 5 | 6 | 7 | 8)] locate
```

Parameter

| Parameter | Description |
|--------------|---|
| driveChannel | The identifier number of the drive channel that you want to locate. Valid values for the identifier number for the drive channel are 1, 2, 3, 4, 5, 6, 7, or 8. Enclose the drive channel identifier number in square brackets ([]). |

Minimum Firmware Level

6.10

7.15 adds an update to the drive channel identifier.

Start Drive Initialize

This command starts drive initialization.

 **ATTENTION Possible damage to the storage array configuration** – As soon as you enter this command, all user data is destroyed.

Syntax

```
start drive [trayID,drawerID,slotID] initialize
```

Parameter

| Parameter | Description |
|-----------|---|
| drive | The location of the drive that you want to reconstruct. For high-capacity drive trays, specify the tray ID value, the drawer ID value, and the slot ID value of the drive that you want to revive. For low-capacity drive trays, specify the tray ID value and the slot ID value of the drive that you want to revive. Tray ID values are 0 to 99. Drawer ID values are 1 to 5. Slot ID values are 1 to 32. Enclose the tray ID value, the drawer ID value, and the slot ID value in square brackets ([]). |

Notes

The `drive` parameter supports both high-capacity drive trays and low-capacity drive trays. A high-capacity drive tray has drawers that hold the drives. The drawers slide out of the drive tray to provide access to the drives. A low-capacity drive tray does not have drawers. For a high-capacity drive tray, you must specify the identifier (ID) of the drive tray, the ID of the drawer, and the ID of the slot in which a drive resides. For a low-capacity drive tray, you need only specify the ID of the drive tray and the ID of the slot in which a drive resides. For a low-capacity drive tray, an alternative method for identifying a location for a drive is to specify the ID of the drive tray, set the ID of the drawer to 0, and specify the ID of the slot in which a drive resides.

Minimum Firmware Level

6.10

7.60 adds the `drawerID` user input.

Start Drive Locate

This command locates a drive by turning on an indicator light on the drive. (Run the `stop drive locate` command to turn off the indicator light on the drive.)

Syntax

```
start drive [trayID,drawerID,slotID] locate
```

Parameter

| Parameter | Description |
|--------------------|---|
| <code>drive</code> | The location of the drive that you want to reconstruct. For <code>high#capacity</code> drive trays, specify the tray ID value, the drawer ID value, and the slot ID value of the drive that you want to revive. For <code>low#capacity</code> drive trays, specify the tray ID value and the slot ID value of the drive that you want to revive. Tray ID values are 0 to 99. Drawer ID values are 1 to 5. Slot ID values are 1 to 32. Enclose the tray ID value, the drawer ID value, and the slot ID value in square brackets ([]). |

Notes

The `drive` parameter supports both high-capacity drive trays and `low#capacity` drive trays. A high-capacity drive tray has drawers that hold the drives. The drawers slide out of the drive tray to provide access to the drives. A `low#capacity` drive tray does not have drawers. For a high-capacity drive tray, you must specify the identifier (ID) of the drive tray, the ID of the drawer, and the ID of the slot in which a drive resides. For a `low#capacity` drive tray, you need only specify the ID of the drive tray and the ID of the slot in which a drive resides. For a `low#capacity` drive tray, an alternative method for identifying a location for a drive is to specify the ID of the drive tray, set the ID of the drawer to 0, and specify the ID of the slot in which a drive resides.

Minimum Firmware Level

6.10

7.60 adds the `drawerID` user input.

Start Drive Reconstruction

This command starts reconstructing a drive.

Syntax

```
start drive [trayID,drawerID,slotID] reconstruct
```

Parameter

| Parameter | Description |
|-----------|---|
| drive | The location of the drive that you want to reconstruct. For high-capacity drive trays, specify the tray ID value, the drawer ID value, and the slot ID value of the drive that you want to revive. For low-capacity drive trays, specify the tray ID value and the slot ID value of the drive that you want to revive. Tray ID values are 0 to 99. Drawer ID values are 1 to 5. Slot ID values are 1 to 32. Enclose the tray ID value, the drawer ID value, and the slot ID value in square brackets ([]). |

Notes

The `drive` parameter supports both high-capacity drive trays and low-capacity drive trays. A high-capacity drive tray has drawers that hold the drives. The drawers slide out of the drive tray to provide access to the drives. A low-capacity drive tray does not have drawers. For a high-capacity drive tray, you must specify the identifier (ID) of the drive tray, the ID of the drawer, and the ID of the slot in which a drive resides. For a low-capacity drive tray, you need only specify the ID of the drive tray and the ID of the slot in which a drive resides. For a low-capacity drive tray, an alternative method for identifying a location for a drive is to specify the ID of the drive tray, set the ID of the drawer to 0, and specify the ID of the slot in which a drive resides.

Minimum Firmware Level

5.43

7.60 adds the `drawerID` user input.

Start Host Interface Card Diagnostic

This command runs diagnostic tests to evaluate the functionality of the controller host interface card. The diagnostic tests that this command runs are specific to the host interface card that is in the controller. Before you run these tests, you must make these changes to the controller that has the host interface card on which you want to run diagnostics:

- Place the controller into service mode (use the `set controller [(a | b)] availability=serviceMode` command).
- Attach the management client directly to the controller through the management Ethernet port.



NOTE In a dual controller configuration, you must run these diagnostic tests through the controller that you want to evaluate. You cannot run these diagnostic tests through the partner controller.

Syntax

```
start hostCard [(1 | 2 | 3 | 4)] controller [(a | b)] diagnostic
diagnosticType=(basic | extended)
[extendedTestID=(EDC | DMA | RAM | internalLoopback)]
```

Parameters

| Parameter | Description |
|----------------|--|
| hostCard | The identifier for host interface card on which you want to run the diagnostic tests. Valid host interface card identifiers are 1, 2, 3, or 4. The value of the identifier is for the position of the host interface card in the controller tray or controller-drive tray. The position of the host interface card depends on the type of controller tray or controller-drive tray in your storage array. See the Notes for more information about the host interface card identifier and the position of the host interface cards in a controller tray. Enclose the controller identifier in square brackets ([]). |
| controller | The controller that has the host interface card on which you want to run the diagnostic tests. Valid controller identifiers are a or b , where a is the controller in slot A, and b is the controller in slot B. Enclose the controller identifier in square brackets ([]). If you do not specify a controller, the storage management software returns a syntax error. |
| diagnosticType | The level of diagnostic testing that you want to run on the host interface card. You can run one of these levels of testing: basic – This option validates the ability of the host interface card to transport I/O data. This option takes approximately 30 seconds to complete. extended – This option enables you to run more comprehensive diagnostic tests on the host interface card. |
| extendedTestID | This parameter selects the extended test option that you want to run. If you choose the <code>extended</code> parameter, you also must use the <code>extendedTestID</code> parameter and one of the extended test options. |

| Extended Test Option for Fibre Channel | Description |
|--|--|
| EDC | This option tests the Error Detection and Correction (EDC) generation, verification, and deletion functionality of the QE4 chip. This option tests all modes of the EDC operation, such as, insert, verify, and delete EDC data. |
| DMA | This option tests the capability of the QE4 chip to take part in a Direct Memory Access (DMA) operation. The DMA can be internal to the chip or can be |

| Extended Test Option for Fibre Channel | Description |
|--|---|
| | performed using the services of the raw pool within the Reconfigurable Processor Assembly (RPA) memory. |

| Extended Test Option for iSCSI | Description |
|--------------------------------|---|
| RAM | This option performs a read/write test for the local RAM, the SRAM, and also performs a checksum test for the NVRAM. This option performs the read/write test for the RAM and SRAM by writing data to the memory, reading back the data, and comparing the read data to the written data. |
| internalLoopBack | This option tests the ability of the physical layer (PHY) to transmit data packets over the physical link. For this test, the PHY is set to an internal loopback mode. Data is then transmitted, received, and compared with the original data. The test is run in two passes: <ul style="list-style-type: none"> ▪ For the first pass, the data is predefined by the firmware. ▪ For the second pass, the data is generated externally and then transmitted. |

Notes

You can run the diagnostic test on only one controller in the storage array at any one time.

A controller can have either one or two host interface cards.

- If a controller has one host interface card, the value for the position of each host interface card depends on the position of the controller in the controller tray. The host interface card in the controller in controller tray slot A has a position value of 1. The host interface card in the controller in controller tray slot B has a position value of 2.
- If a controller has two host interface cards, the value for the position of each host interface card depends on the position of the host interface card in the controller and the position of the controller in the controller tray. In most cases the position of the host interface card is identified with labels such as Host Card 1 and Host Card 2 on each controller. The position value of the host interface cards are listed in this table.

| Controller | Host Card Label | Position |
|------------|-----------------|----------|
| A | Host Card 1 | 1 |
| | Host Card 2 | 2 |
| B | Host Card 1 | 3 |
| | Host Card 2 | 4 |

You cannot use a loopback connection for the host interface card that you are testing.

Minimum Firmware Level

7.70 adds the capability for controller host interface card diagnostics.

Start iSCSI DHCP Refresh

This command initiates a refresh of the DHCP parameters for the iSCSI interface. If the configuration method for the interface is not set to DHCP, the procedure returns an error.

Syntax

```
start controller [(a | b)] iscsiHostPort [(1 | 2 | 3 | 4)] dhcpRefresh
```

Parameter

| Parameter | Description |
|---------------|--|
| controller | The identifier letter of the controller that has the iSCSI host ports. Valid controller identifier values are a or b , where a is the controller in slot A, and b is the controller in slot B. |
| iscsiHostPort | The identifier of the iSCSI port for which you want to refresh the DHCP parameters. Enclose the iSCSI host port identifier in square brackets ([]). |

Notes

This operation ends the iSCSI connections for the portal and temporarily brings down the portal.

Minimum Firmware Level

7.10

Start Remote Volume Mirroring Synchronization

This command starts Remote Volume Mirroring synchronization.

Syntax

```
start remoteMirror primary ["volumeName"] synchronize
```

Parameter

| Parameter | Description |
|-----------|--|
| primary | The name of the primary volume for which you want to start synchronization. Enclose the primary volume name in double quotation marks (") inside of square brackets ([]). |

Minimum Firmware Level

6.10

Start Secure Drive Erase

This command erases all of the data from one or more full disk encryption (FDE) drives so that they can be reused as FDE drives. Run this command only when the FDE drives are no longer part of a secure volume group, or when the security key is unknown.

Syntax

```
start secureErase (drive [trayID,slotID] |
drives [trayID1,slotID1 ... trayIDn,slotIDn])
```

Parameters

| Parameter | Description |
|-----------------|--|
| drive or drives | The tray and the slot where the drive resides. Tray ID values are 0 to 99. Slot ID values are 1 to 32. Enclose the tray ID values and the slot ID values in square brackets ([]). |

Notes

The controller firmware creates a lock that restricts access to the FDE drives. FDE drives have a state called Security Capable. When you create a security key, the state is set to Security Enabled, which restricts access to all FDE drives that exist within the storage array.

Minimum Firmware Level

7.40

Start Snapshot Rollback

This command starts a rollback operation for one or more snapshot volumes. The content of the base volume changes immediately to match the point-in-time content of the selected snapshot volume. The base volume immediately becomes available for read/write requests after the rollback operation has successfully completed. To stop a snapshot rollback operation, use the `stop rollback volume` command.

The repository volume that is associated with the snapshot continues to track any new changes between the base volume and the snapshot volume that occur after the rollback operation is completed.

Syntax

```
start rollback (volume [snapshotVolumeName |
volumes [snapshotVolumeName1 ... snapshotVolumeNameN])
```

Parameter

| Parameter | Description |
|-------------------|--|
| volume or volumes | The name of the specific snapshot volume or snapshot volumes for which you want to start a rollback operation. Enclose the snapshot volume name in square brackets ([]). If |

| Parameter | Description |
|-----------|--|
| | the snapshot volume name has special characters, you must also enclose the snapshot volume name in double quotation marks (" ").). |

Minimum Firmware Level

7.80

Start Storage Array iSNS Server Refresh

This command initiates a refresh of the network address information for the iSNS server. If the DHCP server is marginal or unresponsive, the refresh operation can take from two to three minutes to complete.



NOTE This command is for IPv4 only.

Syntax

```
start storageArray isnsServerRefresh
```

Parameter

None.

Notes

If you used the `set storageArray isnsIPv4ConfigurationMethod` command to set the configuration but did not set the configuration to DHCP, running the `start storageArray isnsServerRefresh` returns an error.

Minimum Firmware Level

7.10

Start Storage Array Locate

This command locates a storage array by turning on the indicator lights for the storage array. (Use the `stop storageArray locate` command to turn off the indicator lights for the storage array.)

Syntax

```
start storageArray locate
```

Parameters

None.

Minimum Firmware Level

6.10

Start Tray Locate

This command locates a tray by turning on the indicator light. (Use the `stop tray locate` command to turn off the indicator light for the tray.)

Syntax

```
start tray [trayID] locate
```

Parameter

| Parameter | Description |
|-------------------|---|
| <code>tray</code> | The tray that you want to locate. Tray ID values are 0 to 99. Enclose the tray ID value in square brackets ([]). |

Minimum Firmware Level

6.10

Start Volume Group Defragment

This command starts a defragment operation on the specified volume group.



NOTE Defragmenting a volume group starts a long-running operation that you cannot stop.

Syntax

```
start volumeGroup [volumeGroupName] defragment
```

Parameter

| Parameter | Description |
|--------------------------|--|
| <code>volumeGroup</code> | The alphanumeric identifier of the volume group (including - and _) that you want to defragment. Enclose the volume group identifier in square brackets ([]). |

Notes

Host I/O errors might result in the volume groups with more than 32 volumes. This operation also might result in internal controller reboots because the timeout period ends before the volume group definition is set. If you experience this issue, quiesce the host I/O operations, and try the command again.

Minimum Firmware Level

6.10

Start Volume Group Export

This command moves a volume group into an Exported state. Then you can remove the drives that comprise the volume group and reinstall the drives in a different storage array.

 **NOTE** Within the volume group, you cannot move volumes that are associated with the premium features from one storage array to another storage array.

Syntax

```
start volumeGroup [volumeGroupName] export
```

Parameter

| Parameter | Description |
|-------------|--|
| volumeGroup | The alphanumeric identifier of the volume group (including - and _) that you want to export. Enclose the volume group identifier in square brackets ([]). |

Notes

When this command is successful, you can run the **start volumeGroup import** command to finish moving the volume group to a Complete state, which makes the volume group available to the new storage array.

If this command is unsuccessful because hardware problems prevented the completion of the export, use the **set volumeGroup forceState** command. The **set volumeGroup forceState** command lets you use the **start volumeGroup import** command to import a volume group.

After the volume group is in an Exported state or a Forced state, you can remove the drives that comprise the volume group from the storage array. You can reinstall the drives in a different storage array.

Minimum Firmware Level

7.10

Start Volume Group Import

This command moves a volume group into a Complete state to make a newly introduced volume group available to its new storage array. The volume group must be in an Exported state or a Forced state before you run this command. Upon successfully running the command, the volume group is operational.

 **NOTE** Within the volume group, you cannot move volumes that are associated with the premium features from one storage array to another storage array.

Syntax

```
start volumeGroup [volumeGroupName] import
```

Parameter

| Parameter | Description |
|-------------|--|
| volumeGroup | The alphanumeric identifier of the volume group (including - and _) that you want to import. Enclose the volume group identifier in square brackets ([]). |

Notes

Higher-level volumes that are specifically related to premium features (Snapshot, Remote Volume Mirroring, Volume Copy, mapping, and persistent reservations) are removed as part of the import operation.

You must run the `show volumeGroup importDependencies` command before you run the `start volumeGroup import` command.

Minimum Firmware Level

7.10

Start Volume Group Locate

This command identifies the drives that are logically grouped together to form the specified volume group by blinking the indicator lights on the drives. (Use the `stop volumeGroup locate` command to turn off the indicator lights on the drives.)

Syntax

```
start volumeGroup [volumeGroupName] locate
```

Parameter

| Parameter | Description |
|-------------|---|
| volumeGroup | The alphanumeric identifier of the volume group (including - and _) for which you want to locate the drives that belong to that volume group. Enclose the volume group identifier in square brackets ([]). |

Minimum Firmware Level

6.16

Start Volume Initialization

This command starts the formatting of a volume in a storage array.



NOTE Formatting a volume starts a long-running operation that you cannot stop.

Syntax

```
start volume [volumeName] initialize
```

Parameter

| Parameter | Description |
|-----------|---|
| volume | The name of the volume for which you are starting the formatting. Enclose the volume name in square brackets ([]). If the volume name has special characters, you also must enclose the volume name in double quotation marks (" "). |

Minimum Firmware Level

6.10

Stop Cache Backup Device Diagnostic

This command stops the cache backup device diagnostic tests that were started by the **start cacheBackupDevice diagnostic** command.

Syntax

```
stop cacheBackupDevice controller [(a | b)] diagnostic
```

Parameters

| Parameter | Description |
|------------|--|
| controller | The controller that has the cache backup device on which you are running the diagnostic tests. Valid controller identifiers are a or b , where a is the controller in slot A, and b is the controller in slot B. Enclose the controller identifier in square brackets ([]). If you do not specify a controller, the storage management software returns a syntax error. |

Minimum Firmware Level

7.60 adds the capability for cache backup device diagnostics.

Stop Cache Memory Diagnostic

This command stops the cache memory diagnostic tests that were started by the **start cacheMemory diagnostic** command.

Syntax

```
stop cacheMemory controller [(a | b)] diagnostic
```

Parameter

| Parameter | Description |
|------------|---|
| controller | The controller that has the cache memory on which you are running the diagnostic tests. Valid controller identifiers are a or b , where a is the controller in slot A, and b is the controller in slot B. Enclose the controller identifier in square brackets ([]). If you do not specify a controller, the storage management software returns a syntax error. |

Minimum Firmware Level

7.60 adds the capability for cache memory diagnostics.

Stop Configuration Database Diagnostic

This command stops the diagnostic test to validate the configuration database in the controller firmware that was started by the `start storageArray configDbDiagnostic` command.

Syntax

```
stop storageArray configDbDiagnostic
```

Parameters

None.

Notes

The controller firmware returns a confirmation that the diagnostic test was cancelled.

In addition, you can start the database configuration diagnostic test through the storage management software GUI; however, you cannot stop the database configuration diagnostic test through the storage management software GUI. If you want to stop a running diagnostic test, you must use the `stop storageArray configDbDiagnostic` command.

If you try to use the `stop storageArray configDbDiagnostic` command after validation of the storage array configuration has finished, you do not receive any message that the validation has finished. This behavior is expected.

Minimum Firmware Level

7.75

7.77 refines usage.

Stop Controller Diagnostic

This command stops the controller diagnostic tests that were started by the `start controller diagnostic` command.

Syntax

```
stop controller [(a | b)] diagnostic
```

Parameters

| Parameter | Description |
|------------|---|
| controller | The setting to return information about a specific controller in the storage array. Valid controller identifiers are a or b , where a is the controller in slot A, and b is the controller in slot B. Enclose the controller identifier in square brackets ([]). If you do not specify a controller, the storage management software returns a syntax error. |

Minimum Firmware Level

7.70

Stop Drive Channel Fault Isolation Diagnostics

This command stops the drive channel fault isolation diagnostics, which stops the `start drive channel fault isolation diagnostics` command before it completes.

Syntax

```
stop driveChannel faultDiagnostics
```

Parameters

None.

Notes

Use the `start driveChannel faultDiagnostics` command and the `save driveChannel faultDiagnostics` command with the `stop driveChannel faultDiagnostics` command. These commands are needed to start the diagnostic test and save diagnostic test results to a file.

You can also stop the `start driveChannel faultDiagnostics` command at any time by pressing **Ctrl +C**.

Minimum Firmware Level

7.15

Stop Drive Channel Locate

This command turns off the indicator lights on the drive trays that were turned on by the `start driveChannel locate` command.

Syntax

```
stop driveChannel locate
```

Parameters

None.

Minimum Firmware Level

6.10

Stop Drive Locate

This command turns off the indicator light on the drive that was turned on by the `start drive locate` command.

Syntax

```
stop drive locate
```

Parameters

None.

Minimum Firmware Level

6.10

Stop Host Interface Card Diagnostic

This command stops the host interface card diagnostic tests that were started by the `start host card diagnostic` command.

Syntax

```
stop host card controller [(a | b)] diagnostic
```

Parameters

| Parameter | Description |
|------------|--|
| controller | The controller that has the host interface card on which you are running the diagnostic tests. Valid controller identifiers are a or b , where a is the controller in slot A, and b is the controller in slot B. Enclose the controller identifier in square brackets ([]). If you do not specify a controller, the storage management software returns a syntax error. |

Minimum Firmware Level

7.70 adds the capability for controller host interface card diagnostics.

Stop Snapshot

This command stops a copy-on-write operation.

Syntax

```
stop snapshot (volume [volumeName] |  
volumes [volumeName1 ... volumeNameN])
```

Parameter

| Parameter | Description |
|-------------------|---|
| volume or volumes | The name of the specific volume for which you want to stop a copy-on-write operation. You can enter more than one volume name. Enclose the volume names using one of these forms: <ul style="list-style-type: none"> ▪ On a Windows command line: <code>\\"volumeName\"</code> ▪ In a Windows script engine window: <code>["volumeName"]</code> ▪ On a Linux command line: <code>\\"volumeName\"</code> |

| Parameter | Description |
|-----------|---|
| | <ul style="list-style-type: none"> In a Linux script engine window: ["volumeName"] |

Notes

Names can be any combination of alphanumeric characters, underscore (_), hyphen (-), and pound (#). Names can have a maximum of 30 characters.

One technique for naming the snapshot volume and the snapshot repository volume is to add a hyphenated suffix to the original base volume name. The suffix distinguishes between the snapshot volume and the snapshot repository volume. For example, if you have a base volume with a name of Engineering Data, the snapshot volume can have a name of Engineering Data-S1, and the snapshot repository volume can have a name of EngineeringData-R1.

If you do not choose a name for either the snapshot volume or the snapshot repository volume, the storage management software creates a default name by using the base volume name. An example of the snapshot volume name that the controllers might create is, if the base volume name is aaa and does not have a snapshot volume, the default snapshot volume name is aaa-1. If the base volume already has $n-1$ number of snapshot volumes, the default name is aaa- n . An example of the snapshot repository volume name that the controller might create is, if the base volume name is aaa and does not have a snapshot repository volume, the default snapshot repository volume name is aaa-R1. If the base volume already has $n-1$ number of snapshot repository volumes, the default name is aaa-R n .

Minimum Firmware Level

6.10

Stop Snapshot Rollback

This command stops a snapshot rollback operation that was initiated by the the `start rollback volume` command.



NOTE Canceling a rollback operation leaves the base volume in an indeterminate state with potentially invalid or inconsistent data. The related snapshot volume becomes disabled and unusable.

Syntax

```
stop rollback volume [snapshotVolumeName]
```

Parameter

| Parameter | Description |
|-----------|--|
| volume | The name of the specific snapshot volume for which you want to stop a rollback operation. Enclose the snapshot volume name in square brackets ([]). If the snapshot volume name has special characters, you must also enclose the snapshot volume name in double quotation marks (" "). |

Minimum Firmware Level

7.80

Stop Storage Array Drive Firmware Download

This command stops a firmware download to the drives in a storage array that was started with the `download storageArray driveFirmware` command. This command does not stop a firmware download that is already in progress to a drive. This command stops all firmware downloads to drives that are waiting for the download.

Syntax

```
stop storageArray driveFirmwareDownload
```

Parameters

None.

Minimum Firmware Level

6.10

Stop Storage Array iSCSI Session

This command forces the termination of a storage array iSCSI session.

Syntax

```
stop storageArray iscsiSession [sessionNumber]
```

Parameter

| Parameter | Description |
|---------------------------|--|
| <code>iscsiSession</code> | The identifier number of the iSCSI session. Enclose the identifier number of the iSCSI session in square brackets ([]). |

Minimum Firmware Level

7.10

Stop Storage Array Locate

This command turns off the indicator lights on the storage array that were turned on by the `start storageArray locate` command.

Syntax

```
stop storageArray locate
```

Parameters

None.

Minimum Firmware Level

6.10

Stop Tray Locate

This command turns off the indicator light on the tray that was turned on by the `start tray locate` command.

Syntax

```
stop tray locate
```

Parameters

None.

Minimum Firmware Level

6.10

Stop Volume Copy

This command stops a volume copy operation.

Syntax

```
stop volumeCopy target [targetName] source [sourceName]
```

Parameters

| Parameter | Description |
|-----------|--|
| target | The name of the target volume for which you want to stop a volume copy operation. Enclose the target volume name in square brackets ([]). If the target volume name has special characters, you also must enclose the target volume name in double quotation marks (" "). |
| source | The name of the source volume for which you want to stop a volume copy operation. Enclose the source volume name in square brackets ([]). If the source volume name has special characters, you also must enclose the source volume name in double quotation marks (" "). |

Minimum Firmware Level

5.40

Stop Volume Group Locate

This command turns off the indicator lights on the drives that were turned on by the `start volumeGroup locate` command.

Syntax

```
stop volumeGroup locate
```

Parameters

None.

Minimum Firmware Level

6.16

Suspend Remote Mirror

This command suspends a Remote Volume Mirroring operation.

Syntax

```
suspend remoteMirror (primary [primaryVolumeName]  
primaries [primaryVolumeName1 ... primaryVolumeNameN])  
writeConsistency=(TRUE | FALSE)
```

Parameters

| Parameter | Description |
|--|--|
| <code>primary</code> or <code>primaries</code> | The name of the volume for which you want to suspend operation. Enclose the volume name in square brackets ([]). If the volume name has special characters, you must also enclose the volume name in double quotation marks (" "). |
| <code>writeConsistency</code> | This parameter defines whether the volumes identified in this command are in a write-consistency group or are separate. For the volumes in the same write-consistency group, set this parameter to TRUE . For the volumes that are separate, set this parameter to FALSE . |

Notes

If you set the `writeConsistency` parameter to **TRUE**, the volumes must be in a write-consistency group (or groups). This command suspends all write-consistency groups that contain the volumes. For example, if volumes A, B, and C are in a write-consistency group and they have remote counterparts A', B', and C', the command:

```
suspend remoteMirror volume ["A"] writeConsistency=TRUE
```

suspends A-A', B-B', and C-C'. If you have a write-consistency group 1={A, B, C} and write-consistency group 2={D, E, F}, the command:

```
suspend remoteMirror volumes ["A" "D"] writeConsistency=TRUE
```

suspends both write-consistency groups.

Minimum Firmware Level

6.10

Validate Storage Array Security Key

This command validates the security key for a storage array that has full disk encryption (FDE) drives to make sure that the security key is not corrupt.

Syntax

```
validate storageArray securityKey
file="fileName"
passPhrase="passPhraseString"
```

Parameters

| Parameter | Description |
|------------|--|
| file | The file path and the file name that has the security key. Enclose file path and the file name in double quotation marks (" "). For example: file="C:\Program Files\CLI\sup\seckey.slk" IMPORTANT – The file name must have an extension of .slk. |
| passPhrase | A character string that encrypts the security key so that you can store the security key in an external file. Enclose the pass phrase in double quotation marks (" "). |

Notes

Your pass phrase must meet these criteria:

- The pass phrase must be between eight and 32 characters long.
- The pass phrase must contain at least one uppercase letter.
- The pass phrase must contain at least one lowercase letter.
- The pass phrase must contain at least one number.
- The pass phrase must contain at least one non-alphanumeric character, for example, < > @ +.



NOTE If your pass phrase does not meet these criteria, you will receive an error message.

Minimum Firmware Level

7.70

Deprecated Commands and Parameters

This appendix lists the commands, the command formats, and the parameters that are no longer supported by this level of software. The information is presented in two tables. "" lists commands that are no longer supported in this level of software and the new commands that replaced them. "" lists the parameters that are no longer supported in this level of software and the new parameters that replaced them.

Deprecated Commands

Commands Deprecated in Firmware Release 10.80

| Deprecated Command | New Command |
|---|---|
| <code>recreate storageArray mirrorRepository</code> | With firmware version 7.80, the recreate storageArray mirrorRepository command is deprecated. This functionality is no longer supported in either the GUI or the CLI. If the user attempts to run this command, an error message will be returned indicating that this functionality is no longer supported and that no changes will be made to the specified remote mirror repositories. |
| <code>save storageArray diagnosticData</code> | <code>(save storageArray esm) diagfiles "ifData" ("controller tray</code> The <i>tray</i> parameter replaces the <i>esm</i> parameter. |
| <code>set storageArray autoSupportConfig</code> | <code>(enable disable)</code> The old set storageArray autoSupportConfig command is deprecated to enable the user to specify that the automatic bundling of support information occur at a global level. The ability to enable or disable is still be supported in the appended set storageArray command, and new syntax has been added to the CLI Wrapper to support the collection of data for all storage arrays being managed. |
| <code>show volume actionProgress</code> | With firmware version 7.77, the show volume actionProgress command is deprecated. Replace this command with the show storageArray longRunningOperations command. |

Deprecated Parameters

Parameters Deprecated in Firmware Release 10.80

| Old Syntax | New Syntax |
|---------------------------------------|--|
| <code>drive = tray id, slot id</code> | <code>drive = tray id, drawer id, slot id</code> |

| Old Syntax | New Syntax |
|------------|--|
| | <p>In all commands that require identifying the position of a drive, the <code>drawer id</code> parameter is added to identify the position of a drive in high capacity trays that have drawers. In low capacity trays (those that do not have drawers), you need only specify the <code>tray id</code> parameter and the <code>slot id</code> parameter in which a drive resides.</p> |

Configuring and Maintaining a Storage Array Using the Command Line Interface

This document provides information about configuring and maintaining a storage array using a command line interface. The information explains how to format the commands and provides examples such as creating volume groups and volumes, configuring host, and troubleshooting if problems occur. This document also explains how to use commands to run premium features such as Remote Volume Mirroring. A complete listing of all of the commands and the syntax for those commands is in the *Command Line Interface and Script Commands* document.

This document supports host software version 10.80 and firmware version 7.80.

About the Command Line Interface

The command line interface (CLI) is a software application that provides a way for installers, developers, and engineers to configure and monitor storage arrays. Using the CLI, you can run commands from an operating system prompt, such as the DOS C: prompt, a Linux operating system path, or a Solaris operating system path.

Each command performs a specific action for managing a storage array or returning information about the status of a storage array. You can enter individual commands, or you can run script files when you need to perform operations more than once. For example, you can run script files when you want to install the same configuration on several storage arrays. The CLI enables you to load a script file from a disk and run the script file. The CLI provides a way to run storage management commands on more than one network storage array. You can use the CLI both in installation sites and in development environments.

The CLI gives you direct access to a script engine that is a utility in the SANtricity ES Storage Manager software (also referred to as the storage management software). The script engine runs commands that configure and manage the storage arrays. The script engine reads the commands, or runs a script file, from the command line and performs the operations instructed by the commands.



NOTE You can also access the script engine by using the Enterprise Management Window in the storage management software. If you access the script engine by using the Enterprise Management Window, you can edit or run script commands on only one storage array in the script window. You can open a script window for each storage array in your configuration and run commands in each window. By using the CLI, you can run commands on more than one storage array from a single command line.

You can use the command line interface to perform these actions:

- Directly access the script engine and run script commands
- Create script command batch files to be run on multiple storage arrays when you need to install the same configuration on different storage arrays
- Run script commands on an in-band managed storage array, an out-of-band managed storage array, or a combination of both
- Show configuration information about the network storage arrays
- Add storage arrays to and remove storage arrays from the management domain
- Perform automatic discovery of all of the storage arrays that are attached to the local subnet
- Add or delete Simple Network Management Protocol (SNMP) trap destinations and email alert notifications
- Specify the mail server and sender email address or SNMP server for alert notifications
- Show the alert notification settings for storage arrays that are currently configured in the Enterprise Management Window
- Direct the output to a standard command line display or to a named file

Structure of a CLI Command

The CLI commands are in the form of a command wrapper and elements embedded into the wrapper. A CLI command consists of these elements:

- A command wrapper identified by the term **SMcli**
- The storage array identifier

- Terminals that define the operation to be performed
- Script commands

The CLI command wrapper is a shell that identifies storage array controllers, embeds operational terminals, embeds script commands, and passes these values to the script engine.

All CLI commands have the following structure:

```
SMcli storageArray terminal script-commands;
```

- **SMcli** invokes the command line interface.
- *storageArray* is the name or the IP address of the storage array.
- *terminal* are CLI values that define the environment and the purpose for the command.
- *script-commands* are one or more script commands or the name of a script file that contains script commands. (The script commands configure and manage the storage array.)

If you enter an incomplete or inaccurate **SMcli** string that does not have the correct syntax, parameter names, options, or terminals, the script engine returns usage information.

For an overview of the script commands, see "[About the Script Commands](#)." For definitions, syntax, and parameters for the script commands, refer to the *Command Line Interface and Script Commands for Version 10.77*.

Interactive Mode

If you enter **SMcli** and a storage array name but do not specify CLI parameters, script commands, or a script file, the command line interface runs in interactive mode. Interactive mode lets you run individual commands without prefixing the commands with **SMcli**.

In interactive mode, you can enter a single command, view the results, and enter the next command without typing the complete **SMcli** string. Interactive mode is useful for determining configuration errors and quickly testing configuration changes.

To end an interactive mode session, type the operating system-specific command for terminating a program, such as **Control-C** on the UNIX operating system or the Windows operating system. Typing the termination command (**Control-C**) while in interactive mode turns off interactive mode and returns operation of the command prompt to an input mode that requires you to type the complete **SMcli** string.

CLI Command Wrapper Syntax

General syntax forms of the CLI command wrappers are listed in this section. The general syntax forms show the terminals and the parameters that are used in each command wrapper. The conventions used in the CLI command wrapper syntax are listed in the following table.

| Convention | Definition |
|-------------------------|--|
| a b | Alternative ("a" or "b") |
| <i>italicized-words</i> | A terminal that needs user input to fulfill a parameter (a response to a variable) |

| Convention | Definition |
|---------------------------|---|
| [...] (square brackets) | Zero or one occurrence (square brackets are also used as a delimiter for some command parameters) |
| { ... } (curly braces) | Zero or more occurrences |
| (a b c) | Choose only one of the alternatives |
| bold | A terminal that needs a command parameter entered to start an action |

```
SMcli host-name-or-IP-address [host-name-or-IP-address]
[-c "command; {command2};"]
[-n storage-system-name | -w wwID]
[-o outputfile] [-p password] [-e ] [-S ] [-quick]
```

```
SMcli host-name-or-IP-address [hostname-or-IP-address]
[-fscriptfile]
[-nstorage-system-name | -wwID]
[-ooutputfile] [-ppassword] [-e] [-S] [-quick]
```

```
SMcli (-n storage-system-name | -wwID)
[-c "command; {command2};"]
[-ooutputfile] [-ppassword] [-e] [-S] [-quick]
```

```
SMcli (-nstorage-system-name -wwID)
[-fscriptfile]
[-ooutputfile] [-ppassword] [-e] [-S] [-quick]
```

```
SMcli -aemail:email-address [host-name-or-IP-address1]
[host-name-or-IP-address2]
[-nstorage-system-name | -wwID | -hhost-name]
[-iinformation-to-include] [-qfrequency] [-S]
```

```
SMcli -xemail:email-address [host-name-or-IP-address1]
[host-name-or-IP-address2]
[-nstorage-system-name | -wwID | -hhost-name] [-S]
```

```
SMcli (-a | -x) trap:community, host-name-or-IP-address
[host-name-or-IP-address1 [host-name-or-IP-address2]]
[-nstorage-system-name | -wwID | -hhost-name] [-S]
```

```
SMcli -d [-w] [-i] [-s] [-v] [-S]
```

```
SMcli -mhost-name-or-IP-address-Femail-address
[-gcontactInfoFile] [-S]
```

```
SMcli -A [host-name-or-IP-address [host-name-or-IP-address]]
[-S]
```

```
SMcli -X (-nstorage-system-name | -wwID | -hhost-name)
```

```
SMcli -?
```

Command Line Terminals

| Terminal | Definition |
|--------------------------------|---|
| <i>host-name-or-IP-address</i> | <p>Specifies either the host name or the Internet Protocol (IP) address (<i>xxx.xxx.xxx.xxx</i>) of an in-band managed storage array or an out-of-band managed storage array.</p> <ul style="list-style-type: none"> ▪ If you are managing a storage array by using a host through in-band storage management, you must use the -n terminal or the -w terminal if more than one storage array is connected to the host. ▪ If you are managing a storage array by using out-of-band storage management through the Ethernet connection on each controller, you must specify the <i>host-name-or-IP-address</i> of the controllers. ▪ If you have previously configured a storage array in the Enterprise Management Window, you can specify the storage array by its user-supplied name by using the -n terminal. ▪ If you have previously configured a storage array in the Enterprise Management Window, you can specify the storage array by its World Wide Identifier (WWID) by using the -w terminal. |
| -A | <p>Adds a storage array to the configuration file. If you do not follow the -A terminal with a <i>host-name-or-IP-address</i>, auto-discovery scans the local subnet for storage arrays.</p> |
| -a | <p>Adds a Simple Network Management Protocol (SNMP) trap destination or an email address alert destination.</p> <ul style="list-style-type: none"> ▪ When you add an SNMP trap destination, the SNMP community is automatically defined as the community name for the trap, and the <i>host</i> is the IP address or Domain Name Server (DNS) host name of the system to which the trap should be sent. ▪ When you add an email address for an alert destination, the <i>email-address</i> is the email address to which you want the alert message to be sent. |
| -c | <p>Indicates that you are entering one or more script commands to run on the specified storage array. End each command with a semicolon (;). You cannot place more than one -c terminal on the same command line. You can include more than one script command after the -c terminal.</p> |
| -d | <p>Shows the contents of the script configuration file. The file content has this format:</p> <pre><i>storage-system-name host-name1 host-name2</i></pre> |
| -e | <p>Runs the commands without performing a syntax check first.</p> |
| -F (uppercase) | <p>Specifies the email address from which all alerts will be sent.</p> |

| Terminal | Definition |
|-----------------------|--|
| -f (lowercase) | <p>Specifies a file name that contains script commands that you want to run on the specified storage array. The -f terminal is similar to the -c terminal in that both terminals are intended for running script commands. The -c terminal runs individual script commands. The -f terminal runs a file of script commands.</p> <p>By default, any errors that are encountered when running the script commands in a file are ignored, and the file continues to run. To override this behavior, use the set session errorAction=stop command in the script file.</p> |
| -g | <p>Specifies an ASCII file that contains email sender contact information that will be included in all email alert notifications. The CLI assumes that the ASCII file is text only, without delimiters or any expected format. Do not use the -g terminal if a <code>userdata.txt</code> file exists.</p> |
| -h | <p>Specifies the host name that is running the SNMP agent to which the storage array is connected. Use the -h terminal with these terminals:</p> <ul style="list-style-type: none"> ▪ -a ▪ -x |
| -I (uppercase) | <p>Specifies the type of information to be included in the email alert notifications. You can select these values:</p> <ul style="list-style-type: none"> ▪ eventOnly – Only the event information is included in the email. ▪ profile – The event and array profile information is included in the email. ▪ supportBundle – The event and support bundle information is included in the email. <p>You can specify the frequency for the email deliveries using the -q terminal.</p> |
| -i (lowercase) | <p>Shows the IP address of the known storage arrays. Use the -i terminal with the -d terminal. The file contents has this format:</p> <pre>storage-system-name IP-address1 IPaddress2</pre> |
| -m | <p>Specifies the host name or the IP address of the email server from which email alert notifications are sent.</p> |
| -n | <p>Specifies the name of the storage array on which you want to run the script commands. This name is optional when you use a <i>host-name-or-IP#address</i>. If you are using the in-band method for managing the storage array, you must use the -n terminal if more than one storage array is connected to the host at the specified address. The storage array name is required when the <i>host-name-or-IP-address</i> is not used. The name of the storage array that is configured for use in the Enterprise Management Window (that is, the name is listed in the configuration file) must not be a duplicate name of any other configured storage array.</p> |

| Terminal | Definition |
|---------------|---|
| -o | <p>Specifies a file name for all output text that is a result of running the script commands. Use the -o terminal with these terminals:</p> <ul style="list-style-type: none"> ▪ -c ▪ -f <p>If you do not specify an output file, the output text goes to standard output (stdout). All output from commands that are not script commands is sent to stdout, regardless of whether this terminal is set.</p> |
| -p | <p>Specifies the password for the storage array on which you want to run commands. A password is not necessary under these conditions:</p> <ul style="list-style-type: none"> ▪ A password has not been set on the storage array. ▪ The password is specified in a script file that you are running. ▪ You specify the password by using the -c terminal and this command: <pre>set session password=password</pre> |
| -q | <p>Specifies the frequency that you want to receive event notifications and the type of information returned in the event notifications. An email alert notification containing at least the basic event information is always generated for every critical event. These values are valid for the -q terminal:</p> <ul style="list-style-type: none"> ▪ everyEvent – Information is returned with every email alert notification. ▪ 2 – Information is returned no more than once every two hours. ▪ 4 – Information is returned no more than once every four hours. ▪ 8 – Information is returned no more than once every eight hours. ▪ 12 – Information is returned no more than once every 12 hours. ▪ 24 – Information is returned no more than once every 24 hours. <p>Using the -I terminal you can specify the type of information in the email alert notifications.</p> <ul style="list-style-type: none"> ▪ If you set the -I terminal to eventOnly, the only valid value for the -q terminal is everyEvent. ▪ If you set the -I terminal to either the profile value or the supportBundle value, this information is included with the emails with the frequency specified by the -q terminal. |
| -quick | <p>Reduces the amount of time that is required to run a single-line operation. An example of a single-line operation is the recreate snapshot volume command. This terminal reduces time by not running background processes for the duration of the command. Do not use this terminal for operations that involve more than one single-line operation. Extensive use of this command can overrun the controller with more commands than the controller can</p> |

| Terminal | Definition |
|-----------------------|---|
| | process, which causes operational failure. Also, status updates and configuration updates that are collected usually from background processes will not be available to the CLI. This terminal causes operations that depend on background information to fail. |
| -s (uppercase) | Suppresses informational messages describing the command progress that appear when you run script commands. (Suppressing informational messages is also called silent mode.) This terminal suppresses these messages: <ul style="list-style-type: none"> ▪ Performing syntax check ▪ Syntax check complete ▪ Executing script ▪ Script execution complete ▪ SMcli completed successfully |
| -s (lowercase) | Shows the alert settings in the configuration file when used with the -d terminal. |
| -v | Shows the current global status of the known devices in a configuration file when used with the -d terminal. |
| -w | Specifies the WWID of the storage array. This terminal is an alternate to the -n terminal. Use the -w terminal with the -d terminal to show the WWIDs of the known storage arrays. The file content has this format: <i>storage-system-name world-wide-ID IP-address1 IP-address2</i> |
| -x (uppercase) | Deletes a storage array from a configuration. |
| -x (lowercase) | Removes an SNMP trap destination or an email address alert destination. The <i>community</i> is the SNMP community name for the trap, and the <i>host</i> is the IP address or DNS host name of the system to which you want the trap sent. |
| -? | Shows usage information about the CLI commands. |

Formatting CLI Commands

Double quotation marks (" ") that are used as part of a name or label require special consideration when you run the CLI commands and the script commands on a Microsoft Windows operating system.

When double quotation marks (" ") are part of a name or value, you must insert a backslash (\) before each double quotation mark character. For example:

```
-c "set storageArray userLabel=\"Engineering\";"
```

In this example, "Engineering" is the storage array name. A second example is:

```
-n \"My\"_Array
```

In this example, "My"_Array is the name of the storage array.

You cannot use double quotation marks (" ") as part of a character string (also called string literal) within a script command. For example, you cannot enter the following string to set the storage array name to "Finance" Array:

```
-c "set storageArray userLabel=\"\"Finance\"Array\";"
```

In the Linux operating system and the Solaris operating system, the delimiters around names or labels are single quotation marks (' '). The UNIX versions of the previous examples are as follows:

```
-c 'set storageArray userLabel="Engineering";'
```

```
-n "My"_Array
```

In a Windows operating system, if you do not use double quotation marks (" ") around a name, you must insert a caret (^) before each special script character. Special characters are ^, |, <, and >.

Insert a caret before each special script character when used with the terminals **-n**, **-o**, **-f**, and **-p**. For example, to specify storage array CLI>CLIENT, enter this string:

```
-n CLI^>CLIENT
```

Insert one caret (^) before each special script character when used within a string literal in a script command. For example, to change the name of a storage array to FINANCE_|_PAYROLL, enter the following string:

```
-c "set storageArray userLabel=\"FINANCE_|_PAYROLL\";"
```

Usage Examples

The following examples show how to enter CLI commands on a command line. The examples show the syntax, the form, and, in some examples, script commands. Examples are shown for both the Windows operating system and the UNIX operating system. Note that the usage for the **-c** terminal varies depending on your operating system. On Windows operating systems, enclose the script command following the **-c** terminal in double quotation marks (" "). On UNIX operating systems, enclose the script command following the **-c** terminal in single quotation marks (' '). For descriptions of the script commands used in these examples, refer to the *Command Line Interface and Script Commands for Version 10.75*.

This example shows how to change the name of a storage array. The original name of the storage array is Payroll_Array. The new name is Finance_Array.

Windows operating system:

```
SMcli ICTSANT -n "Payroll_Array" -c "set storageArray userLabel=\"Finance_Array\";"
```

UNIX operating system:

```
SMcli ICTSANT -n 'Payroll_Array' -c 'set storageArray userLabel="Finance_Array";'
```

This example shows how to delete an existing volume and create a new volume on a storage array. The existing volume name is Stocks_<_Bonds. The new volume name is Finance. The controller host names are finance1 and finance2. The storage array is protected, requiring the password TestArray.

Windows operating system:

```
SMcli finance1 finance2 -c "set session password=\"TestArray\";
delete volume [\"Stocks_<Bonds\"];
create volume driveCount[3] RAIDLEVEL=3 capacity=10GB userLabel=\"Finance\";
show storageArray healthStatus;"
```

UNIX operating system:

```
SMcli finance1 finance2 -c 'set session password="TestArray";
delete volume ["Stocks_<Bonds"];
create volume driveCount[3] RAIDLEVEL=3 capacity=10GB userLabel="Finance";
show storageArray healthStatus;'
```

This example shows how to run commands in a script file named `scriptfile.scr` on a storage array named Example. The `-e` terminal causes the file to run without checking the syntax. Running a script file without checking the syntax lets the file run more quickly; however, the file might not run correctly because the syntax for a command might be incorrect.

```
SMcli -n Example -f scriptfile.scr -e
```

This example shows how to run commands in a script file named `scriptfile.scr` on a storage array named Example. In this example, the storage array is protected by the password `MyArray`. Output, as a result of commands in the script file, goes to file `output.txt`.

Windows operating system:

```
SMcli -n Example -f scriptfile.scr -p "My_Array" -o output.txt
```

UNIX operating system:

```
SMcli -n Example -f scriptfile.scr -p 'My_Array' -o output.txt
```

This example shows how to show all of the storage arrays in the current configuration. The command in this example returns the host name of each storage array.

```
SMcli -d
```

If you want to know the IP address of each storage array in the configuration, add the `#i` terminal to the command.

```
SMcli -d -i
```

Exit Status

This table lists the exit statuses that might be returned and the meaning of each status.

| Status Value | Meaning |
|--------------|---|
| 0 | The command terminated without an error. |
| 1 | The command terminated with an error. Information about the error also appears. |
| 2 | The script file does not exist. |

| Status Value | Meaning |
|---------------------|---|
| 3 | An error occurred while opening an output file. |
| 4 | A storage array was not at the specified address. |
| 5 | Addresses specify different storage arrays. |
| 6 | A storage array name does not exist for the host agent that is connected. |
| 7 | The storage array name was not at the specified address. |
| 8 | The storage array name was not unique. |
| 9 | The storage array name was not in the configuration file. |
| 10 | A management class does not exist for the storage array. |
| 11 | A storage array was not found in the configuration file. |
| 12 | An internal error occurred. |
| 13 | Invalid script syntax was found. |
| 14 | The controller was unable to communicate with the storage array. |
| 15 | A duplicate argument was entered. |
| 16 | An execution error occurred. |
| 17 | A host was not at the specified address. |
| 18 | The WWID was not in the configuration file. |
| 19 | The WWID was not at the address. |
| 20 | An unknown IP address was specified. |
| 21 | The Event Monitor configuration file was corrupted. |
| 22 | The storage array was unable to communicate with the Event Monitor. |
| 23 | The controller was unable to write alert settings. |
| 24 | The wrong organizer node was specified. |
| 25 | The command was not available. |
| 26 | The device was not in the configuration file. |
| 27 | An error occurred while updating the configuration file. |
| 28 | An unknown host error occurred. |

| Status Value | Meaning |
|--------------|---|
| 29 | The sender contact information file was not found. |
| 30 | The sender contact information file could not be read. |
| 31 | The <code>userdata.txt</code> file exists. |
| 32 | An invalid <code>-I</code> value in the email alert notification was specified. |
| 33 | An invalid <code>-F</code> value in the email alert notification was specified. |

About the Script Commands

You can use the script commands to configure and manage a storage array. The script commands are distinct from the command line interface (CLI) command wrappers. You can enter individual script commands, or you can run a file of script commands. When you enter an individual script command, you embed the script command in a CLI command wrapper. When you run a file of script commands, you embed the file name in the CLI command wrapper. The script commands are processed by a script engine that performs the following functions:

- Verifies the command syntax
- Interprets the commands
- Converts the commands to the appropriate protocol-compliant commands
- Passes the commands to the storage array

At the storage array, the storage array controllers run the script commands.

The script engine and the script commands support the storage array configuration and management operations that are listed in the following table.

Configuration and Management Operations

| Operation | Activities |
|---|--|
| General storage array configuration | Resetting a configuration to defaults, labeling, checking the health status, setting the time of day, clearing the Event Log, and setting the media scan rate |
| Volume configuration and volume group configuration | Creating, deleting, and setting the reconstruction priority control; labeling; setting drive composition when creating volumes; setting the segment size; and setting the media scan control |
| Drive configuration | Assigning hot spares |
| Controller configuration | Defining volume ownership, changing mode settings, defining network settings, and setting host channel IDs |
| Firmware management | Downloading controller firmware, the environmental services monitor (ESM) firmware, and the drive firmware |
| NVSRAM configuration | Downloading and modifying the user configuration region at the bit level and the byte level, showing nonvolatile static random access memory (NVSRAM) values |
| Cache configuration | Controlling all cache parameters, both at the storage array level and the individual volume level |
| Product identification | Retrieving the tray profile display data |
| Battery management | Setting the battery installation date |

Structure of a Script Command

All script commands have the following structure:

command operand-data (statement-data)

- *command* identifies the action to be performed.
- *operand-data* represents the objects associated with a storage array that you want to configure or manage.
- *statement-data* provides the information needed to perform the command.

The syntax for *operand-data* has the following structure:

```
(object-type | allobject-types | [qualifier]
(object-type [identifier] {object-type [identifier]}) | object-types [identifier-list]
```

An object can be identified in four ways:

- Object type – Use when the command is not referencing a specific object.
- all parameter prefix – Use when the command is referencing all of the objects of the specified type in the storage array (for example, allVolumes).
- Square brackets – Use when performing a command on a specific object to identify the object (for example, volume [engineering]).
- A list of identifiers – Use to specify a subset of objects. Enclose the object identifiers in square brackets (for example, volumes [sales engineering marketing]).

A qualifier is required if you want to include additional information to describe the objects.

The object type and the identifiers that are associated with each object type are listed in this table.

Script Command Object Type Identifiers

| Object Type | Identifier |
|------------------|--|
| controller | a or b |
| drive | Tray ID and slot ID |
| replacementDrive | Tray ID and slot ID |
| driveChannel | Drive channel identifier |
| host | User label |
| hostChannel | Host channel identifier |
| hostGroup | User label |
| hostPort | User label |
| iscsiInitiator | User label or iSCSI Qualified Name (IQN) |
| iscsiTarget | User label or IQN |
| remoteMirror | Primary volume user label |
| snapshot | Volume user label |

| Object Type | Identifier |
|--------------|---|
| storageArray | Not applicable |
| tray | Tray ID |
| volume | Volume user label or volume World Wide Identifier (WWID) (set command only) |
| volumeCopy | Target volume user label and, optionally, the source volume user label |
| volumeGroup | User label Valid characters are alphanumeric, a hyphen, and an underscore. |

Statement data is in the form of:

- Parameter = value (such as `raidLevel=5`)
- Parameter-name (such as `batteryInstallDate`)
- Operation-name (such as `redundancyCheck`)

A user-defined entry (such as user label) is called a variable. In the syntax, it is shown in *italic* (such as *trayID* or *volumeGroupName*).

Synopsis of the Script Commands

Because you can use the script commands to define and manage the different aspects of a storage array (such as host topology, drive configuration, controller configuration, volume definitions, and volume group definitions), the actual number of commands is extensive. The commands, however, fall into general categories that are reused when you apply the commands to the different to configure or maintain a storage array. The following table lists the general form of the script commands and a definition of each command.

General Form of the Script Commands

| Syntax | Description |
|---|---|
| <code>activate <i>object</i></code> <code>{<i>statement-data</i>}</code> | Sets up the environment so that an operation can take place or performs the operation if the environment is already set up correctly. |
| <code>autoConfigure storageArray</code> <code>{<i>statement-data</i>}</code> | Automatically creates a configuration that is based on the parameters that are specified in the command. |
| <code>check <i>object</i></code> <code>{<i>statement-data</i>}</code> | Starts an operation to report on errors in the object, which is a synchronous operation. |
| <code>clear <i>object</i></code> <code>{<i>statement-data</i>}</code> | Discards the contents of some attributes of an object. This operation is destructive and cannot be reversed. |
| <code>create <i>object</i></code> <code>{<i>statement-data</i>}</code> | Creates an object of the specified type. |

| Syntax | Description |
|---|--|
| <code>deactivate object {statement-data}</code> | Removes the environment for an operation. |
| <code>delete object</code> | Deletes a previously created object. |
| <code>diagnose object {statement-data}</code> | Runs a test and shows the results. |
| <code>disable object {statement-data}</code> | Prevents a feature from operating. |
| <code>download object {statement-data}</code> | Transfers data to the storage array or to the hardware that is associated with the storage array. |
| <code>enable object {statement-data}</code> | Sets a feature to operate. |
| <code>load object {statement-data}</code> | Transfers data to the storage array or to the hardware that is associated with the storage array. This command is functionally similar to the <code>download</code> command. |
| <code>recopy object {statement-data}</code> | Restarts a volume copy operation by using an existing volume copy pair. You can change the parameters before the operation is restarted. |
| <code>recover object {statement-data}</code> | Re-creates an object from saved configuration data and the statement parameters. (This command is similar to the <code>create</code> command.) |
| <code>recreate object {statement-data}</code> | Restarts a snapshot operation by using an existing snapshot volume. You can change the parameters before the operation is restarted. |
| <code>remove object {statement-data}</code> | Removes a relationship from between objects. |
| <code>repair object {statement-data}</code> | Repairs errors found by the <code>check</code> command. |
| <code>reset object {statement-data}</code> | Returns the hardware or an object to an initial state. |
| <code>resume object</code> | Starts a suspended operation. The operation starts where it left off when it was suspended. |
| <code>revive object</code> | Forces the object from the Failed state to the Optimal state. Use this command only as part of an error recovery procedure. |
| <code>save object {statement-data}</code> | Writes information about the object to a file. |

| Syntax | Description |
|--|--|
| <code>set object</code> { <i>statement-data</i> } | Changes object attributes. All changes are completed when the command returns. |
| <code>show object</code> { <i>statement-data</i> } | Shows information about the object. |
| <code>start object</code> { <i>statement-data</i> } | Starts an asynchronous operation. You can stop some operations after they have started. You can query the progress of some operations. |
| <code>stop object</code> { <i>statement-data</i> } | Stops an asynchronous operation. |
| <code>suspend object</code> { <i>statement-data</i> } | Stops an operation. You can then restart the suspended operation, and it continues from the point where it was suspended. |

Recurring Syntax Elements

Recurring syntax elements are a general category of parameters and options that you can use in the script commands. The [Recurring Syntax Elements](#) table lists the recurring syntax parameters and the values that you can use with the recurring syntax parameters. The conventions used in the recurring syntax elements are listed in the following table.

| Convention | Definition |
|---------------------------|---|
| a b | Alternative ("a" or "b") |
| <i>italicized-words</i> | A terminal that needs user input to fulfill a parameter (a response to a variable) |
| [...] (square brackets) | Zero or one occurrence (square brackets are also used as a delimiter for some command parameters) |
| { ... } (curly braces) | Zero or more occurrences |
| (a b c) | Choose only one of the alternatives |
| bold | A terminal that needs a command parameter entered to start an action |

Recurring Syntax Elements

| Recurring Syntax | Syntax Value |
|------------------------------|--|
| <i>raid-level</i> | (0 1 3 5 6) |
| <i>repository-raid-level</i> | (1 3 5 6) |
| <i>capacity-spec</i> | <i>integer-literal</i> [KB MB GB TB Bytes] |

| Recurring Syntax | Syntax Value |
|---|---|
| <i>segment-size-spec</i> | <i>integer-literal</i> |
| <i>boolean</i> | (TRUE FALSE) |
| <i>user-label</i> | <i>string-literal</i> Valid characters are alphanumeric, the dash, and the underscore. |
| <i>user-label-list</i> | <i>user-label</i> { <i>user-label</i> } |
| <i>create-raid-vol-attr-value-list</i> | <i>create-raid-volume-attribute-value-pair</i> { <i>create-raid-volume-attribute-value-pair</i> } |
| <i>create-raid-volume-attribute-value-pair</i> | capacity= <i>capacity-spec</i> owner=(a b) cacheReadPrefetch=(TRUE FALSE) segmentSize= <i>integer-literal</i> usageHint= <i>usage-hint-spec</i> |
| <i>noncontroller-trayID</i> | (0-99) |
| <i>slotID</i> | (1-32) |
| <i>portID</i> | (0-127) |
| <i>drive-spec</i> | <i>trayID</i> , <i>slotID</i> or <i>trayID</i> , <i>drawerID</i> , <i>slotID</i> A drive is defined as two or three interger literal values separated by a comma. Low-density trays require two values. High-density trays, those trays that have drawers, require three values. |
| <i>drive-spec-list</i> | <i>drive-spec</i> <i>drive-spec</i> |
| <i>trayID-list</i> | <i>trayID</i> { <i>trayID</i> } |
| <i>esm-spec-list</i> | <i>esm-spec</i> { <i>esm-spec</i> } |
| <i>esm-spec</i> | <i>trayID</i> , (left right) |
| <i>hex-literal</i> | <i>0xhexadecimal-literal</i> |
| <i>volumeGroup-number</i> | <i>integer-literal</i> |
| <i>filename</i> | <i>string-literal</i> |
| <i>error-action</i> | (stop continue) |
| <i>drive-channel-identifier</i> (four drive ports per tray) | (1 2 3 4) |
| <i>drive-channel-identifier</i> (eight drive ports per tray) | (1 2 3 4 5 6 7 8) |
| <i>drive-channel-identifier-list</i> | <i>drive-channel-identifier</i> { <i>drive-channel#identifier</i> } |

| Recurring Syntax | Syntax Value |
|---|---|
| <i>host-channel-identifier</i> (four host ports per tray) | (a1 a2 b1 b2) |
| <i>host-channel-identifier</i> (eight host ports per tray) | (a1 a2 a3 a4 b1 b2 b3 b4) |
| <i>host-channel-identifier</i> (16 host ports per tray) | (a1 a2 a3 a4 a5 a6 a7 a8 b1 b2 b3 b4 b5 b6 b7 b8) |
| <i>drive-type</i> | (fibre SATA SAS) |
| <i>drive-media-type</i> | (HDD SSD unknown allMedia) <i>HDD</i> means hard disk drive. <i>SSD</i> means solid state disk. |
| <i>feature-identifier</i> | (storagePartition2 storagePartition4 storagePartition8 storagePartition16 storagePartition64 storagePartition96 storagePartition128 storagePartition256 storagePartitionMax snapshot snapshot2 snapshot4 snapshot8 snapshot16 remoteMirror8 remoteMirror16 remoteMirror32 remoteMirror64 remoteMirror128 volumeCopy goldKey mixedDriveTypes highPerformanceTier SSDSupport safeStoreSecurity safeStoreExternalKeyMgr dataAssurance) To use the High Performance Tier premium feature, you must configure a storage array as one of these: <ul style="list-style-type: none"> ▪ SHIPPED_ENABLED ▪ SHIPPED_ENABLED=FALSE; KEY_ENABLED=TRUE |
| <i>repository-spec</i> | <i>instance-based-repository-spec</i> <i>count-based-repository-spec</i> |
| <i>instance-based-repository-spec</i> | (repositoryRAIDLevel = <i>repository-raid-level</i> repositoryDrives= (<i>drive-spec-list</i>) [repositoryVolumeGroupUserLabel = <i>user-label</i>] [trayLossProtect=(TRUE FALSE) ¹]) [drawerLossProtect=(TRUE FALSE) ²]) (repositoryVolumeGroup= <i>user-label</i> |

| Recurring Syntax | Syntax Value |
|---|--|
| | <p>[freeCapacityArea=<i>integer-literal</i>³])</p> <p>Specify the <code>repositoryRAIDLevel</code> parameter with the <code>repositoryDrives</code> parameter. Do not specify the RAID level or the drives with the volume group. Do not set a value for the <code>trayLossProtect</code> parameter when you specify a volume group.</p> |
| <i>count-based-repository-spec</i> | <p><code>repositoryRAIDLevel</code> <code>=repository-raid-level</code> <code>repositoryDriveCount=integer-literal</code> [<code>repositoryVolumeGroupUserLabel</code> <code>=user-label</code>] [<code>driveType=drive-type⁴] [<code>trayLossProtect=(TRUE FALSE)¹] [<code>drawerLossProtect=(TRUE FALSE)²] [<code>dataAssurance=(none enabled)⁵] </code></code></code></code></p> |
| <i>wwID</i> | <i>string-literal</i> |
| <i>gid</i> | <i>string-literal</i> |
| <i>host-type</i> | <i>string-literal</i> <i>integer-literal</i> |
| <i>host-card-identifier</i> | (1 2 3 4) |
| <i>backup-device-identifier</i> | (1 n all) n is a specific slot number. Specifying a11 includes all of the cache backup devices available to the entire storage array. |
| <i>nvsram-offset</i> | <i>hex-literal</i> |
| <i>nvsram-byte-setting</i> | <i>nvsram-value = 0hexadecimal</i> <i>integer-literal</i> The <i>0hexadecimal</i> value is typically a value from 0x0000 to 0xFFFF. |
| <i>nvsram-bit-setting</i> | <i>nvsram-mask, nvsram-value = 0hexadecimal, 0hexadecimal</i> <i>integer-literal</i> The <i>0hexadecimal</i> value is typically a value from 0x0000 to 0xFFFF. |
| <i>ip-address</i> | (0-255).(0-255).(0-255).(0-255) |
| <i>ipv6-address</i> | (0-FFFF):(0-FFFF):(0-FFFF):(0-FFFF):(0-FFFF):(0-FFFF):(0-FFFF):(0-FFFF) You must enter all 32 hexadecimal characters. |
| <i>autoconfigure-vols-attr-value-list</i> | <i>autoconfigure-vols-attr-value-pair</i> { <i>autoconfigure-vols-attr-value-pair</i> } |

| Recurring Syntax | Syntax Value |
|--|--|
| <i>autoconfigure-vols-attr-value-pair</i> | driveType= <i>drive-type</i> driveMediaType= <i>drive-media-type</i> raidLevel= <i>raid-level</i> volumeGroupWidth= <i>integer-literal</i> volumeGroupCount= <i>integer-literal</i> volumesPerGroupCount= <i>integer-literal</i> ⁶ hotSpareCount= <i>integer-literal</i> segmentSize= <i>segment-size-spec</i> cacheReadPrefetch=(TRUE FALSE) securityType=(none capable enabled) ⁷ dataAssurance=(none enabled) ⁵ |
| <i>create-volume-copy-attr-value-list</i> | <i>create-volume-copy-attr-value-pair</i> { <i>create-volume-copy-attr-value-pair</i> } |
| <i>create-volume-copy-attr-value-pair</i> | copyPriority=(highest high medium low lowest) targetReadOnlyEnabled=(TRUE FALSE) copyType=(offline online) repositoryPercentOfBase=(20 40 60 120 default) repositoryGroupPreference=(sameAsSource otherThanSource default) |
| <i>recover-raid-volume-attr-value-list</i> | <i>recover-raid-volume-attr-value-pair</i> { <i>recover-raid-volume-attr-value-pair</i> } |
| <i>recover-raid-volume-attr-value-pair</i> | owner=(a b) cacheReadPrefetch=(TRUE FALSE) dataAssurance=(none enabled) |
| <i>cache-flush-modifier-setting</i> | immediate, 0, .25, .5, .75, 1, 1.5, 2, 5, 10, 20, 60, 120, 300, 1200, 3600, infinite |
| <i>serial-number</i> | string-literal |
| <i>usage-hint-spec</i> | usageHint=(multiMedia database fileSystem) |
| <i>iscsiSession</i> | [<i>session-identifier</i>] |
| <i>iscsi-host-port</i> | (1 2 3 4) The host port number might be 2, 3, or 4 depending on the type of controller you are using. |
| <i>ethernet-port-options</i> | enableIPv4=(TRUE FALSE) enableIPv6=(TRUE FALSE) IPv6LocalAddress= <i>ipv6-address</i> IPv6RoutableAddress= <i>ipv6-address</i> IPv6RouterAddress= <i>ipv6-address</i> |

| Recurring Syntax | Syntax Value |
|---|---|
| | IPv4Address= <i>ip-address</i> IPv4ConfigurationMethod= (static dhcp) IPv4GatewayIP= <i>ip-address</i> IPv4SubnetMask= <i>ip-address</i> duplexMode=(TRUE FALSE) portSpeed=(autoNegotiate 10 100 1000) |
| <i>iscsi-host-port-options</i> | IPv4Address= <i>ip-address</i> IPv6LocalAddress= <i>ipv6-address</i> IPv6RoutableAddress= <i>ipv6-address</i> IPv6RouterAddress= <i>ipv6-address</i> enableIPv4=(TRUE FALSE) enableIPv6=(TRUE FALSE) enableIPv4Priority=(TRUE FALSE) enableIPv6Priority=(TRUE FALSE) IPv4ConfigurationMethod= (static dhcp) IPv6ConfigurationMethod= (static auto) IPv4GatewayIP= <i>ip-address</i> IPv6HopLimit= <i>integer</i> IPv6NdDetectDuplicateAddress= <i>integer</i> IPv6NdReachableTime= <i>time-interval</i> IPv6NdRetransmitTime= <i>time-interval</i> IPv6NdTimeOut= <i>time-interval</i> IPv4Priority= <i>integer</i> IPv6Priority= <i>integer</i> IPv4SubnetMask= <i>ip-address</i> IPv4VlanId= <i>integer</i> IPv6VlanId= <i>integer</i> maxFramePayload= <i>integer</i> tcpListeningPort= <i>tcp-port-id</i> portSpeed=(autoNegotiate 1 10) |
| <i>test-devices-list</i> | <i>test-devices</i> { <i>test-devices</i> } |
| <i>test-devices</i> | controller=(a b) esms=(<i>esm-spec-list</i>) drives=(<i>drive-spec-list</i>) |
| <i>snapshot-schedule-attribute-value-list</i> | <i>snapshot-schedule-attribute-value-pair</i> { <i>snapshot-schedule-attribute-value-pair</i> } |
| <i>time-zone-spec</i> | (GMT+HH:MM GMT-HH:MM) [dayLightSaving=HH:MM] |
| <i>snapshot-schedule-attribute-value-pair</i> | startDate=MM:DD:YY scheduleDay=(<i>dayOfWeek</i> all) startTime=HH:MM scheduleInterval= <i>interger</i> endDate=(MM:DD:YY noEndDate) |

| Recurring Syntax | Syntax Value |
|------------------|--|
| | <code>timesPerDay=<i>interger</i></code> |

¹For tray loss protection to work, each drive in a volume group must be in a separate tray. If you set the `trayLossProtect` parameter to **TRUE** and you have selected more than one drive from any one tray, the storage array returns an error. If you set `trayLossProtect` parameter to **FALSE**, the storage array performs operations, but the volume group that you create might not have tray loss protection.

If you set the `trayLossProtect` parameter to **TRUE**, the storage array returns an error if the controller firmware cannot find drives that will enable the new volume group to have tray loss protection. If you set the `trayLossProtect` parameter to **FALSE**, the storage array performs the operation even if it means that the volume group might not have tray loss protection.

²In trays that have drawers for holding the drives, drawer loss protection determines whether data on a volume is accessible or inaccessible if a drawer fails. To help make sure that your data is accessible, set the `drawerLossProtect` parameter to **TRUE**. For drawer loss protection to work, each drive in a volume group must be in separate drawers. If you have a storage array configuration in which a volume group spans several trays, you must make sure that the setting for drawer loss protection works with the setting for tray loss protection. If you set the `trayLossProtect` parameter to **TRUE**, you must set the `drawerLossProtect` parameter to **TRUE**. If you set the `trayLossProtect` parameter to **TRUE**, and you set the `drawerLossProtect` parameter to **FALSE**, the storage array returns an error message and a storage array configuration will not be created.

³To determine if a free capacity area exists, run the `show volumeGroup` command.

⁴The default drive (drive type) is **fibre** (Fibre Channel).

The `driveType` parameter is not required if only one type of drive is in the storage array. If you use the `driveType` parameter, you also must use the `hotSpareCount` parameter and the `volumeGroupWidth` parameter. If you do not use the `driveType` parameter, the configuration defaults to Fibre Channel drives.

⁵The `dataAssurance` parameter applies to the drives in a volume group. Using the `dataAssurance` parameter, you can specify that protected drives must be selected for a volume group. If you want to set the `dataAssurance` parameter to **enabled**, all of the drives in the volume group must be capable of data assurance. You cannot have a mix of drives that are capable of data assurance and drives that are not capable of data assurance in the volume group.

⁶The `volumesPerGroupCount` parameter is the number of equal-capacity volumes per volume group.

⁷The `securityType` parameter enables you to specify the security setting for a volume group that you are creating. All of the volumes are also set to the security setting that you choose. Available options for setting the security setting include:

- **none** – The volume group is not secure.
- **capable** – The volume group is security capable, but security has not been enabled.
- **enabled** – The volume group is security enabled.



NOTE A storage array security key must already be created for the storage array if you want to set `securityType=enabled`. (To create a storage array security key, use the `create storageArray securityKey` command).

Usage Guidelines

This list provides guidelines for writing script commands on the command line:

- You must end all commands with a semicolon (;).
- You can enter more than one command on a line, but you must separate each command with a semicolon (;).
- You must separate each base command and its associated primary parameters and secondary parameters with a space.
- The script engine is not case sensitive. You can enter commands by using uppercase letters, lowercase letters, or mixed-case letters.
- Add comments to your scripts to make it easier for you and future users to understand the purpose of the script commands. (For information about how to add comments, see ["Adding Comments to a Script File."](#))



NOTE While the CLI commands and the script commands are not case sensitive, user labels (such as for volumes, hosts, or host ports) are case sensitive. If you try to map to an object that is identified by a user label, you must enter the user label exactly as it is defined, or the CLI commands and the script commands will fail.

Adding Comments to a Script File

The script engine looks for certain characters or a command to show comments. You can add comments to a script file in three ways:

1. Add text after two forward slashes (//) as a comment until an end-of-line character is reached. If the script engine does not find an end-of-line character in the script after processing a comment, an error message appears, and the script operation is terminated. This error usually occurs when a comment is placed at the end of a script and you have forgotten to press the **Enter** key.

```
// Deletes the existing configuration.  
set storageArray resetConfiguration=true;
```

2. Add text between /* and */ as a comment. If the script engine does not find both a starting comment notation and an ending comment notation, an error message appears, and the script operation is terminated.

```
/* Deletes the existing configuration */  
set storageArray resetConfiguration=true;
```

3. Use the **show** statement to embed comments in a script file that you want to appear while the script file is running. Enclose the text that you want to appear by using double quotation marks ("").

```
show "Deletes the existing configuration";  
set storageArray resetConfiguration=true;
```

Configuring a Storage Array

This chapter explains how to run script commands from the command line to create a volume from a collection of drives and how to configure a redundant array of independent disks (RAID) storage array. This chapter assumes that you have a basic understanding of RAID concepts and terminology. Before you begin to configure your storage array, become familiar with these concepts:

- Controllers
- Drives
- Hot spares
- Volume groups
- Volumes
- RAID technology
- Hosts
- Host groups
- Host bus adapter (HBA) host ports
- Logical unit numbers (LUNs)

Configuring a RAID storage array requires caution and planning to make sure that you define the correct RAID level and configuration for your storage array. The main purpose in configuring a storage array is to create volumes, which are addressable by the hosts, from a collection of drives. The commands described in this chapter enable you to set up and run a RAID storage array. Additional commands are also available to provide you with more control and flexibility in managing and maintaining your storage array.



NOTE Many of these commands require a thorough understanding of the firmware as well as an understanding of the network components that need to be mapped. Use the CLI commands and the script commands with caution.

The sections in this chapter show some, but not all, of the CLI wrapper commands and the script commands. The commands in this chapter show how you can use the commands to configure a storage array. These presentations do not describe all possible usage and syntax for the commands. For complete definitions of the commands, including syntax, parameters, and usage notes, refer to the *Command Line Interface and Script Commands*.

This chapter contains examples of CLI command usage and script command usage. The command syntax that is used in the examples is for a host running a Microsoft operating system. As part of the examples, the complete `C:\` prompt and the DOS path for the commands are shown. Depending on your operating system, the prompt and path construct will vary.

For most commands, the syntax is the same for all Windows operating systems and UNIX operating systems, as well as for a script file. Windows operating systems, however, have an additional requirement when entering names on a command line. On Windows operating systems, you must enclose the name between two back slashes (`\ \`) in addition to other delimiters. For example, the following name is used in a command running under a Windows operating system:

```
[ \ "Engineering\ " ]
```

For a UNIX operating system, and when used in a script file, the name appears as follows:

```
[ "Engineering" ]
```

Configuration Concepts

When you configure a storage array, you organize drives into a logical structure that provides storage capacity and data protection so that one or more hosts can safely store data in the storage array. This section provides definitions of the physical and logical components required to organize the physical disks into a storage array configuration. This section also describes how the components relate to each other.

Controllers

All storage arrays have one or two controllers. The controllers are circuit-board assemblies that manage data and communication between the hosts and the storage array. The controller manages the data flow between the hosts and the drives, keeping track of the logical address of where the data resides. In general, each controller has a processor for performing control operations, NVSRAM for storing the firmware code that operates the storage array, and the buses along which the data flows.

The controllers are located in a controller tray or a controller-drive tray. The controller tray or a controller-drive tray has two positions for controllers: slot A and slot B. The script commands identify each controller by the slot in which the controller is installed. If controller tray or a controller-drive tray has only one controller, the controller must be in slot A. A controller tray or a controller-drive tray with two controllers is called a duplex tray. A controller tray or a controller-drive tray with one controller is called a simplex tray.

Early controller models FC1250 and FC1275 used minihubs; two connected to each controller. When viewed from the rear of the controller tray, the host-side minihubs are numbered from left-to-right a1, b1, a2, and b2. The script commands identify the host channels by using these identifiers. Minihubs also support the drive-side, where each minihub represents a single channel to the drives. When viewed from the rear of the controller tray, the drive minihubs are numbered from left to right 4, 3, 2, and 1. The script commands use these numbers to identify the drive channels.

Controller models SAT2700 and SHV2600 are used in an early controller-drive tray that has a slot where either a controller or an environmental services monitor (ESM) can be used. When an ESM is used, the tray is called a drive tray.

Controllers manage the interface by running controller firmware to transmit and receive commands between the hosts and the drives. Host bus adapters facilitate the communication through whichever interface is selected. Typically, two host bus adapters and two paths are used to optimize redundancy.

The controller-drive trays and controller trays incorporate all host connections and drive tray connections into each controller. The host ports must be identified in your command statements to let you complete their network configurations.

The more recent models of controllers do not use minihubs. These controllers have host ports that are integrated into the controller circuit boards or auxiliary circuit boards that are directly connected to the controller circuit boards.

The following table lists the controller-drive trays that do not use minihubs, the type of host port, and the number of host ports.

Host Ports and Host Interfaces for Controllers

| Model | Available Host Ports | Type of Host Interface |
|------------------------------|----------------------|------------------------|
| AM1331 controller-drive tray | 1 | SAS |

| Model | Available Host Ports | Type of Host Interface |
|-------------------------------|----------------------|--|
| AM1333 controller-drive tray | 3 | SAS |
| AM1532 controller-drive tray | 2 | iSCSI |
| AM1932 controller-drive tray | 2 | Fibre Channel |
| CE2600 controller-drive tray | 2 or 4 | SAS |
| | 4 | Fibre Channel |
| | 4 | iSCSI |
| CDE3992 controller-drive tray | 2 | Fibre Channel |
| CDE3994 controller-drive tray | 4 | Fibre Channel |
| CE6998 controller tray | 4 | Fibre Channel |
| CE7900 controller tray | 16 | Fibre Channel |
| | 4 | iSCSI The four iSCSI host connections are used with eight Fibre Channel host connections. |

The AM1333 controller-drive tray has three host ports that are numbered from left to right: host port 1, host port 2, and host port 3 as seen from the rear of the controller-drive tray.

The AM1532 and AM1932 controller-drive trays have two host ports on each controller, which are numbered from left to right: host port 1 and host port 2 as seen from the rear of the controller-drive tray.

The host ports on the CDE3994 controller-drive tray are numbered from left-to-right on controller B as Ch 1, Ch 2, Ch 3, and Ch 4. Controller A, which is installed upside-down in the controller-drive tray, is numbered from right-to-left in the same sequence.

The controller in the CE6998 controller tray can have up to four host channels with one port for each channel; up to two drive channels with two ports per channel (for a total of four drive ports); and up to two Ethernet ports. In the CE6998 controller tray, the controllers are stacked one above the other. The top controller is A. The bottom controller is B.

For controller A, the host channel identifiers are a1, a2, a3, and a4, and the host bus adapter (HBA) host ports are labeled 1, 2, 3, and 4. For controller B, the host channel identifiers are b1, b2, b3, and b4, and the HBA host ports are labeled 1, 2, 3, and 4.

Controller A has drive channels 1 and 2. Drive ports labeled 3 and 4 connect to drive channel 1. Drive ports labeled 1 and 2 connect to Drive Channel 2. Controller B has drive channels 3 and 4. Drive ports labeled 1 and 2 connect to drive channel 3. Drive ports labeled 3 and 4 connect to drive channel 4. Each Ethernet port on a controller can have a unique IP address; however, both Ethernet ports share the same gateway IP address, subnet mask, and remote login settings.

Each of the two controllers in the CE7900 controller tray can have two host cards with four host ports on each card. Some CE7900 controller trays can have controllers with only one host card each. Controller A is inverted from controller B, which means that its host channels are upside-down.

Drives

The drives store the data that is sent to the storage array. The drives are mounted in either a controller-drive tray or a drive tray. The controller-drive tray has drives and controllers in one tray. A drive tray has only drives, and is connected to a controller through an environmental services monitor (ESM). In addition to the drives and ESMs, the drive tray contains power supplies and fans. These components support drive tray operation and can be maintained through the CLI.

Drives are located in a storage array by tray ID and slot ID. Tray ID values are 0 to 99. In older trays, tray ID values are set during installation by switches on the rear of the trays. In newer trays, tray ID values are set automatically when the power is applied.

The slot ID is the drive position in the drive tray. A drive tray can contain 12, 14, 16, 24, or 60 drives. In drive trays with fewer than 60 drives, slot ID values range from 1 to 32. In drive trays with 60 drives, slot ID values are defined by the drawer number and the position of the drive in the drawer. The drawer numbers range from 1 to 5, counting from top to bottom. The position of each drive in a drawer is shown in the following figure.

Drive Drawer with Drives

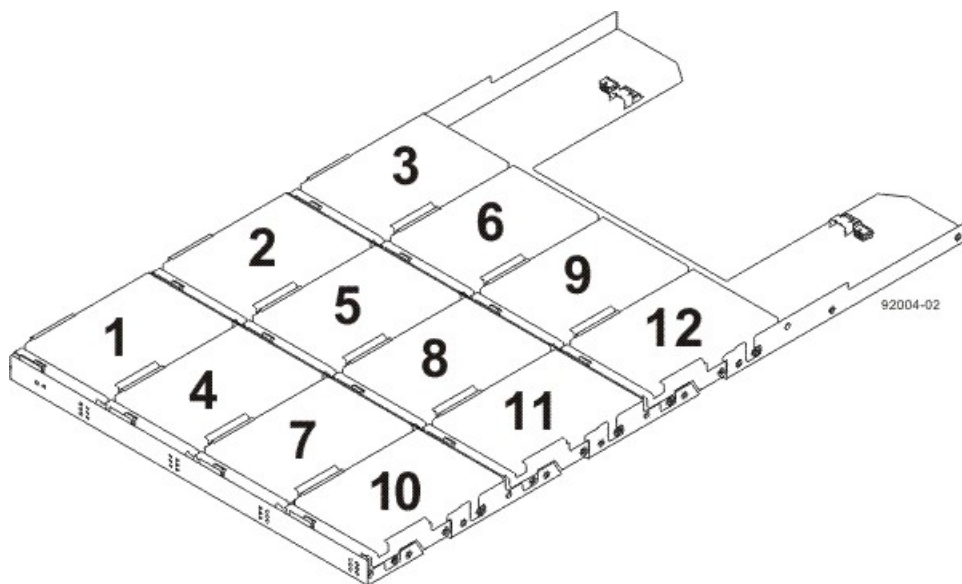

The total number of drives in a storage array depends on the model of the controller tray or controller-drive tray and the capacity of the drives. The following table lists, by controller tray or controller-drive tray model and drive tray capacity, the maximum number of drives in a storage array.

Maximum Number of Drives Supported

| Controller Model | 12-Drive Drive Tray | 14-Drive Drive Tray | 16-Drive Drive Tray | 24-Drive Drive Tray | 60-Drive Drive Tray |
|------------------|---------------------|---------------------|---------------------|---------------------|---------------------|
| AM1331 AM1333 | 48 | | | | |

| Controller Model | 12-Drive Drive Tray | 14-Drive Drive Tray | 16-Drive Drive Tray | 24-Drive Drive Tray | 60-Drive Drive Tray |
|-----------------------------|---------------------|---------------------|---------------------|---------------------|---------------------|
| AM1532 | 48 | | | | |
| AM1932 | 48 | | | | |
| CE2600 (simplex controller) | 96 | | | 96 | |
| CE2600 (duplex controller) | 192 | | | 192 | |
| CDE3992 | | 112 | 112 | | |
| CDE3994 | | 112 | 112 | | |
| CE4900 | | 112 | 112 | | |
| CE6998 | | 224 | 224 | | |
| CE7900 | | | 256 | | 480 |



NOTE A maximum of seven drive trays can be on a channel when mixing 14-slot drive trays and 16-slot drive trays.

The maximum capacity in a storage array depends on the number of the drives in the and storage array the capacity of each drive in the storage array. The following table lists the maximum storage for each controller model based on the capacity of the drives.

Maximum Capacity with Supported Drives

| Drive Capacity | AM1331 AM1333 AM1532 AM1932 | CE2600 | CDE3992/ CDE3994 | CE4900 | CE6998 | CE7900 |
|----------------|--------------------------------------|---------|---------------------|--------|---------|--------|
| 73#GB FC | | | 8.0 TB | | 16.4 TB | |
| 73#GB SAS | 3.5 TB | | | | | |
| 146#GB FC | | | 16.0 TB | | 32.7 TB | |
| 146#GB SAS | 7.0 TB | 28.0 TB | | | | |

| Drive Capacity | AM1331 AM1333 AM1532 AM1932 | CE2600 | CDE3992/ CDE3994 | CE4900 | CE6998 | CE7900 |
|----------------|--------------------------------------|----------|---------------------|----------|----------|----------|
| 150#GB SAS | | 28.8 TB | | | | |
| 300#GB FC | | | 34.0 TB | | 67.2 TB | |
| 300#GB SAS | 14.4 TB | 57.6 TB | | | | |
| 450#GB FC | | | | 50.0 TB | | 201.0 TB |
| 450#GB SAS | | 86.4 TB | | | | |
| 500#GB SATA | 24.0 TB | | 56.0 TB | | 112.0 TB | |
| 500#GB SAS | | 96.0 TB | | | | |
| 600#GB SAS | | 115.2 TB | | | | |
| 750#GB SATA | 36.0 TB | | | | | |
| 1.0#TB SAS | | 192.0 TB | | | | |
| 1.0#TB SATA | 48.0 TB | | | 112.0 TB | | 480.0 TB |

Hot Spare Drives

A hot spare is a drive that acts as a standby in the event that a drive containing data fails. The hot spare is a drive that has not been assigned to a particular volume group and, as such, can be used in any volume group. You can use the hot spare feature with RAID Level 1, RAID Level 3, RAID Level 5, or RAID Level 6. If a drive in a volume group fails, the controllers automatically replace the failed drive with a hot spare. The controllers use redundancy data to reconstruct the data from the failed drive onto the hot spare. To be most effective, the drive that you assign as a hot spare must have a capacity equal to or greater than the capacity of the largest drive in the storage array. The hot spare must be the same type of drive as the drive that failed (for example, a Serial Advanced Technology Attachment [SATA] hot spare cannot replace a Fibre Channel hot spare).

You can assign drives to act as hot spares manually or have the script commands automatically assign hot spares. If you manually assign a drive to be a hot spare, you must identify the drive by tray ID and slot ID. When you let the script commands automatically assign hot spares, you must enter the number of hot spares that you want in the storage array.

SafeStore Drive Security with Full Disk Encryption

SafeStore Drive Security is a premium feature that prevents unauthorized access to the data on a drive that is physically removed from the storage array. Controllers in the storage array have a *security key*. Secure drives provide access to data only through a controller that has the correct security key. SafeStore Drive Security is a premium feature of the storage management software and must be enabled either by you or your storage vendor.

The SafeStore Drive Security premium feature requires security capable drives. A security capable drive encrypts data during writes and decrypts data during reads. Each security capable drive has a unique drive encryption key.

When you create a secure volume group from security capable drives, the drives in that volume group become security enabled. When a security capable drive has been security enabled, the drive requires the correct security key from a controller to read or write the data. All of the drives and controllers in a storage array share the same security key. The shared security key provides read and write access to the drives, while the drive encryption key on each drive is used to encrypt the data. A security capable drive works like any other drive until it is security enabled.

Whenever the power is turned off and turned on again, all of the security-enabled drives change to a *security locked* state. In this state, the data is inaccessible until the correct security key is provided by a controller.

You can view the SafeStore Drive Security status of any drive in the storage array from the **Drive Properties** dialog. The drive can have one of these capabilities:

- Security Capable
- Secure – Security enabled or disabled
- Read/Write Accessible – Security locked or unlocked

You can view the SafeStore Drive Security status of any volume group in the storage array by using the **show volume group** command. The volume group can have one of these capabilities:

- Security Capable
- Secure

The following table shows how to interpret the security properties status of a volume group.

Volume Group Security Properties

| | Security Capable – yes | Security Capable – no |
|---------------------|---|---|
| Secure – yes | The volume group is composed of all full disk encryption (FDE) drives and is in a Secure state. | Not applicable. Only FDE drives can be in a Secure state. |
| Secure – no | The volume group is composed of all FDE drives and is in a Non-Secure state. | The volume group is not entirely composed of FDE drives. |

You can erase security-enabled drives so that you can reuse the drives in another volume group or in another storage array. Use the **start secure erase** command to completely erase any data on a security-enabled drive. Using the **start secure erase** command results in the loss of all of the data on a drive, and is irreversible. You can never recover the data.

The storage array password protects a storage array from potentially destructive operations by unauthorized users. The storage array password is independent from the SafeStore Drive Security premium feature and should not be confused with the pass phrase that is used to protect copies of a security key. However, it is good practice to set a storage array password before you create, change, or save a security key or unlock secure drives.

Commands for FDE Drives

You can use these commands to enable security in the FDE drives and manage the drives.

- `activate hostPort`
- `activate iscsiInitiator`
- `create volume` – Automatic drive select
- `create volume` – Free extent based select
- `create volume` – Manual drive select
- `create storageArray securityKey`
- `create volumeGroup`
- `enable volumeGroup security`
- `export storageArray securityKey`
- `import storageArray securityKey`
- `set controller`
- `set storageArray securityKey`
- `show drive`
- `start secure erase`

Volume Groups

A volume group is a set of drives that are logically grouped together by the controllers in a storage array. After you create a volume group, you can create one or more volumes in the volume group. A volume group is identified by a sequence number that is defined by the controller firmware when you created the volume group.



NOTE Some storage arrays permit different drive types in the same tray; however, you cannot have a combination of different drives in the same volume group.

To create a volume group, you must define the capacity and the RAID level.

Capacity is the size of the volume group. Capacity is determined by the number of drives that you assign to the volume group. You can use only unassigned drives to create a volume group. (In this programming guide, the storage space on unassigned drives constitutes the unconfigured capacity of a storage array.)

Free capacity is a contiguous region of unassigned capacity in a designated volume group. Before you create a new volume in a volume group, you need to know the free capacity space so that you can determine the size of the volume.

The RAID level is the level of data protection that you want to define for your storage array. The RAID level that you choose affects storage capacity. When you configure your storage array, you must consider this compromise between data protection and storage capacity. In general, the more protection that you need, the less storage capacity is available in your storage array.

The following table lists the minimum number of drives and the maximum number of drives that you can use in a volume group based on the RAID level that you want to assign to the volume group.

Maximum Number of Drives in a Volume Group Based on RAID Level

| RAID Level | Minimum Number of Drives | Maximum Number of Drives | Redundancy |
|------------|--------------------------|--------------------------|----------------|
| 0 | 1 | All | None |
| 1 | 1 | All | Mirrored pairs |
| 3 | 3 | 30 | 1 drive |
| 5 | 3 | 30 | 1 drive |
| 6 | 5 | 30 | 2 drives |

You can determine the size of the volume group by multiplying the maximum number of drives in the volume group by the capacity of the smallest drive in the volume group.

Volumes

A volume is a logical component (object) that is the basic structure that is created on the storage array to store data. A volume is a contiguous subsection of a volume group that is configured to meet application needs for data availability and I/O performance. The storage management software administers a volume as if the volume is one “drive” for data storage. Volumes are identified by names or labels that users choose. The volume names can be any combination of alphanumeric characters, hyphens (-), and underscores (_). The maximum length of a volume name is 30 characters.

The script commands support the following types of volumes:

- **Standard volume** – A logical structure that is the principal type of volume for data storage. A standard volume is the most common type of volume in a storage array.
- **Access volume** – A factory-configured volume in a storage area network (SAN) environment that is used for communication between the storage management software and the storage array controller. The access volume uses a logical unit number (LUN) address and consumes 20 MB of storage space. The 20 MB of access volume storage space is not available for data storage.



NOTE Use the access volume only for in-band-managed storage arrays.

- **Snapshot volume** – A logical point-in-time image of another volume. A snapshot volume is the logical equivalent of a complete physical copy; however, it is not an actual, physical copy. Instead, the firmware tracks only the data blocks that are overwritten and copies those blocks to a snapshot repository volume.
- **Snapshot repository volume** – A special volume in the storage array that is created as a resource for a snapshot volume. A snapshot repository volume contains snapshot data and copy-on-write data for a particular snapshot volume.

- **Base volume** – A standard volume from which you create a snapshot volume. The term “base volume” is used only to show the relationship between a standard volume from which you are taking the point-in-time image and a snapshot volume.
- **Primary volume** – A standard volume in a Remote Volume Mirroring relationship. The primary volume accepts host data transfers and stores application data. When you first create the mirror relationship, data from the primary volume is copied in its entirety to the associated secondary volume.
- **Secondary volume** – A standard volume in a Remote Volume Mirroring relationship that maintains a mirror (or copy) of the data from its associated primary volume. The secondary volume remains unavailable to host applications while mirroring is underway. In the event of a disaster or a catastrophic failure of the primary site, a system administrator can promote the secondary volume to a primary role.
- **Mirror repository volume** – A special volume in a Remote Volume Mirroring configuration that is created as a resource for each controller in both the local storage array and the remote storage array. The controller stores mirroring information on this volume, including information about remote writes that are not yet complete. A controller can use this information to recover from controller resets and accidental power shutdown of the storage arrays.

 **NOTE** Snapshot Volume and Remote Volume Mirroring are premium features that you must activate before you can use them. For more information about snapshot volumes, see [“Using the Snapshot Premium Feature.”](#) For more information about Remote Volume Mirroring, see [“Using the Remote Volume Mirroring Premium Feature.”](#)

The number and capacity of the volumes in your storage array depends on the type of controller in the storage array. The following table lists the maximum number of volumes in a storage array that each controller model supports.

Maximum Number of Volumes Each Controller Model Supports

| Specification | AM1331 AM1333 AM1532 AM1932 | CE2600 | CDE3992 or CDE3994 | CE4900 | CE6998 or CE7900 |
|--|---|--------|--------------------------|--------|------------------------|
| Maximum number of volumes per storage array | 256 | 256 | 1024 | 1024 | 2048 |
| Maximum number of volumes per volume group | 256 | 256 | 256 | 256 | 256 |
| Maximum volume size | Number of drives supported by array x (capacity of largest supported drive by array – 512 MB) | | | | |
| Maximum number of drives per volume group using RAID Level 5 | 30 | 30 | 30 | 30 | 30 |
| Maximum number of remote mirrors | 16 | 16 | 64 | 64 | 128 |

 **NOTE** The maximum volume size is limited by the size of the drives and the configuration of the storage array. The last 512 MB on each drive is reserved for storage array configuration database and potential future expansion. For practical considerations, you want to constrain the maximum volume size so that drive replacement and volume reconstruction does not take an excessive amount of time.

RAID Levels

The RAID level defines a storage architecture in which the storage capacity on the drives in a volume group is separated into two parts: part of the capacity stores the user data, and the remainder stores redundant or parity information about the user data. The RAID level that you choose determines how user data is written to and retrieved from the drives. Using the script commands, you can define five RAID levels: RAID Level 0, RAID Level 1, RAID Level 3, RAID Level 5, and RAID Level 6. Each level provides different performance and protection features.

RAID Level 0 provides the fastest storage access but does not provide any redundant information about the stored data. RAID Level 1, RAID Level 3, RAID Level 5, and RAID Level 6 write redundancy information to the drives to provide fault tolerance. The redundancy information might be a copy of the data or an error-correcting code that is derived from the data. In RAID Level 1, RAID Level 3, RAID Level 5, or RAID Level 6 configurations, if a drive fails, the redundancy information can be used to reconstruct the lost data. Regardless of the RAID level that you choose, you can configure only one RAID level across each volume group. All redundancy information for a volume group is stored within the volume group. The following table lists the RAID levels and describes the configuration capabilities of each level.

RAID Level Configurations

| RAID Level | Configuration |
|------------|--|
| 0 | Non-redundant striping mode – Use this level for high-performance needs. RAID Level 0 does not provide any data redundancy. RAID Level 0 stripes data across all of the drives in the volume group. If a single drive fails, all of the associated volumes fail and all data is lost. RAID Level 0 is suited for noncritical data. It is not recommended for high-availability needs. |
| 1 | Striping mirroring mode – RAID Level 1 uses drive mirroring to create an exact copy from one drive to another drive. A minimum of two drives are required; one for the user data, and one for the mirrored data. RAID Level 1 offers high performance and the best data availability. Data is written to two drives simultaneously. If one drive in a drive pair fails, the system can instantly switch to the other drive without any loss of data or service. Only half of the drives in the volume group are available for user data. If a single drive fails in a RAID Level 1 volume group, all of the associated volumes become degraded, but the mirror drive provides access to the data. RAID Level 1 can survive multiple drive failures as long as no more than one failure occurs per mirrored pair. If a drive pair fails, all of the associated volumes fail, and all data is lost. |
| 3 | High-bandwidth mode – RAID Level 3 stripes both user data and redundancy data (in the form of parity) across the drives. The equivalent of the capacity of one drive is used for the redundancy data. RAID Level 3 works well for large data transfers in applications, such as multimedia or medical imaging, that write and read large sequential chunks of data. If a single drive fails in a RAID Level 3 volume group, all of the associated volumes become degraded, but the redundancy data lets the data be reconstructed. If two or more drives fail, all of the associated volumes fail, and all data is lost. |

| RAID Level | Configuration |
|------------|---|
| 5 | <p>High I/O mode – RAID Level 5 stripes both user data and redundancy data (in the form of parity) across the drives. The equivalent of the capacity of one drive is used for the redundancy data. RAID Level 5 works well for multiuser environments, such as databases or file system storage, where typical I/O size is small, and a high proportion of read activity exists.</p> <p>If a single drive fails in a RAID Level 5 volume group, all of the associated volumes become degraded, and the redundancy data permits the data to be reconstructed. If two or more drives fail, all of the associated volumes fail, and all data is lost.</p> |
| 6 | <p>Data protection or continuous access mode – RAID Level 6 stripes both user data and redundancy data (in the form of parity) across the drives. A minimum of five drives are required for a RAID Level 6 volume group. The equivalent capacity of two drives is used for the redundancy data. Two different algorithms calculate redundancy data, which are in the form of both a P parity and a Q parity.</p> <p>RAID Level 6 works well for larger drive sizes. Recovery from a second drive failure in the same volume group is possible. If two drives fail in a RAID Level 6 volume group, all of the associated volumes become degraded, but the redundancy data permits the data to be reconstructed. If three or more drives fail, all of the associated volumes fail, and all data is lost.</p> |

 **NOTE** RAID Level 6 is only available to those controllers that are capable of supporting the P+Q calculation. The model CE6998 controller does not support RAID Level 6. The CE2600, CDE3992, CDE3994, CE4900, and CE7900, controllers support RAID Level 6. A premium feature key enables customers to use RAID Level 6 and to use dynamic RAID-level migration. Refer to the "Set Volume Group" command in *Command Line Interface and Script Commands for Version 10.75* for information explaining how to set your volume group to RAID Level 6.

Hosts

A host is a computer that is attached to the storage array for accessing the volumes in the storage array. The host is attached to the storage array through HBA host ports, which are connectors on host bus adapter circuit boards. You can define specific volume-to-LUN mappings to an individual host or assign the host to a host group that shares access to one or more volumes. Hosts are identified by names or labels that users choose. The host name can be any combination of alphanumeric characters, hyphens, and underscores. The maximum length of the host name is 30 characters.

In addition to a host name, some script commands require you to identify a host by its A host type identifies the operating system under which the host is running (such as Windows, Solaris, or Linux). Specifying the host type lets the controllers in the storage array adapt their behavior (such as LUN reporting and error conditions) to the operating system of the host that is sending the information. Host types are identified by a label or an index number that is generated by the controller firmware.

Host Groups

A host group is a topological element that you can define if you want to designate a collection of hosts that will share access to the same volumes. A host group is a logical entity. Host groups are identified by names or labels that users choose. The host group name can be any combination of alphanumeric characters with a maximum length of 30 characters.

Host Bus Adapter Host Ports

A host bus adapter (HBA) provides the physical connection from the host to the storage array. The host port is a physical connector on an HBA. The HBA is a circuit board that is installed in the host. The HBA can have one or more host ports. Each host port is identified by a unique, 16-byte World Wide Identifier (WWID). If the HBA has more than one host port, each host port has a unique ID.

When you first turn on the power to a storage array, the storage management software automatically detects the HBA host ports. Initially, all detected host ports belong to a default group. You can use script commands to identify the WWIDs on a storage array and, if you choose, change them. If you move an HBA host port, you must remap any volume-to-LUN mappings. Access to your data is lost until you remap the volumes.

The maximum number of HBA host ports that you can logically define for your storage array depends on the type of controller in the storage array. The following table lists the maximum number of HBA host ports that you can define.

Maximum Number of HBA Host Ports per Controller

| Controller Models | Maximum Number of Host Ports |
|------------------------|------------------------------|
| 1331, 1333, 1532, 1932 | 256 |
| CE2600 | 256 |
| CDE3992 or CDE3994 | 256 |
| CE4900 | 256 |
| CE6998 | 512 |
| CE7900 | 1024 |

Logical Unit Numbers

In the context of the CLI commands and the script commands, a logical unit number (LUN) is a unique value that identifies the volumes in a storage array. The hosts identify the volumes that they want to access using the LUN values. When you create a volume, the firmware assigns the LUN values, or you can assign LUN values when you enable the SANshare Storage Partitioning premium feature. A volume can have only one LUN and can be mapped to only one host or host group. Each host has unique addressing capability. That is, when more than one host accesses a storage array, each host might use the same LUN to access different volumes. The LUNs might be the same, but the volumes are different. If you are mapping to a host group, the LUN that you specify must be available on every host in the host group.

Configuring a Storage Array

When you configure a storage array, you want to maximize the data availability by making sure that the data is quickly accessible while maintaining the highest level of data protection possible. The speed by which a host can access data is affected by these items:

- The RAID level for the volume group
- The settings for the segment size and the cache size
- Whether the cache read prefetch capability is turned on or turned off

Data protection is determined by the RAID level, hardware redundancy (such as global hot spares), and software redundancy (such as the Remote Volume Mirroring premium feature and the Snapshot Volume premium feature).

In general, you configure a storage array by defining a volume group and its associated RAID level, defining the volumes, and defining which hosts have access to the volumes. This section explains how to use the script commands to perform the general steps to create a configuration from an array of drives.

Determining What Is on Your Storage Array

Even when you create a configuration on a storage array that has never been configured, you still need to determine the hardware features and software features that are to be included with the storage array. When you configure a storage array that has an existing configuration, you must make sure that your new configuration does not inadvertently alter the existing configuration, unless you are reconfiguring the entire storage array. For example, consider the case where you want to create a new volume group on unassigned drives. Before you create a new volume group, you must determine which drives are available. The commands that are described in this section help you to determine the components and the features in your storage array.

The command that returns general information about the storage array is the **show storageArray** command. This command returns information about the components and properties of your storage array, including these items:

- A detailed profile of the components and features in the storage array
- The age of the battery
- The default host type (which is the current host type)
- Other host types that you can select
- The hot spare locations
- The identifiers for enabled premium features
- The logical component profiles and the physical component profiles
- The time to which both controllers are set
- The controller that currently owns each volume in the storage array

To return the most information about the storage array, run the **show storageArray** command with the **profile** parameter. This example shows the complete CLI command and script command running on a Windows operating system:

```
c:\...\smX\client>smcli 123.45.67.88 123.45.67.89  
-c "show storageArray profile;"
```

This example identifies the storage array by the IP addresses 123.45.67.88123.45.67.89. These addresses are the IP addresses of the controllers in the storage array. You can also identify the storage array by name.

The **show storageArray profile** command returns detailed information about the storage array. The information appears in several display screens. You might need to increase the size of your display buffer to see all of the information. Because this information is so detailed, you might want to save the output to a file. To save the output to a file, enter the command as shown in this example:

```
c:\...\smX\client>smcli 123.45.67.88 123.45.67.89  
-c "show storageArray profile;" -o  
c:\folder\storagearrayprofile.txt
```

In this example, the name `folder` is the folder in which you choose to place the profile file, and `storagearrayprofile.txt` is the name of the file. You can choose any folder and any file name.

 **ATTENTION Possible loss of data** – When you write information to a file, the script engine does not check to determine if the file name already exists. If you choose the name of a file that already exists, the script engine writes over the information in the file without warning.

The topic "[Examples of Information Returned by the Show Commands](#)," shows the type of information returned. When you save the information to a file, you can use the information as a record of your configuration and as an aid during recovery.

To return a brief list of the storage array features and components, use the `summary` parameter. The command looks like this example:

```
c:\...\smX\client>smcli 123.45.67.88 123.45.67.89
-c "show storageArray summary;"
```

Following is the type of information that is returned by the `show storageArray` command with the `summary` parameter.

```
SUMMARY_ _ _ _ _ _ _ _ _ _ _
Number of controllers: 1
Number of volume groups: 2
Total number of volumes (includes access volume): 3 of 2048    used
    Number of standard volumes: 5
    Number of access volumes: 1
    Number of snapshot repositories:0
Number of snapshot volumes: 0
Number of copies: 0
Number of drives: 9
Supported drive types: Fibre (9)
Total hotspare drives: 1
    Standby: 1
    In use: 0
Access volume: LUN 7 (see Mappings section for details)
Default host type: Linux (host type index 6)
Current configuration
    Firmware version: PkgInfo ww.xx.yy.zz
    NVSRAM version: N1111-234567-001
Pending configuration
    Staged firmware download supported: Yes
    Firmware version: Not applicable
    NVSRAM version: Not applicable
    Transferred on: Not applicable
NVSRAM configured for batteries: Yes
Start cache flushing at (in percentage): 80
Stop cache flushing at (in percentage): 80
Cache block size (in KB): 4
Media scan frequency (in days): Disabled
Failover alert delay (in minutes): 5
Feature enable identifier: 1234567891011121314151617181ABCD
```

The summary information is also returned as the first section of information when you use the `profile` parameter.

The **show** commands return information about the specific components of a storage array. The information returned by each of the **show** commands is the same as the information returned by the **show storageArray profile** command, but the information is constrained to the specific component. Following is a list of the **show** commands.

- **show controller**
- **show drive**
- **show driveChannels stats**
- **show storageArray hostTopology**
- **show storageArray lunMappings**
- **show allVolumes**
- **show volumeGroup**
- **show volume reservations**
- **show controller NVSRAM**
- **show remoteMirror candidates**
- **show storageArray autoConfigure**
- **show storageArray unreadableSectors**
- **show volumeCopy sourceCandidates**
- **show volumeCopy targetCandidates**
- **show volume performanceStat**

Clearing the Configuration

If you want to create a completely new configuration on a storage array that already has an existing configuration, use the **clear storageArray configuration** command. This command deletes all of the existing configuration information, including all of the volume groups, volumes, and hot spare definitions from the controller memory.



ATTENTION Possible damage to the storage array configuration – As soon as you run this command, the existing storage array configuration is deleted.

The command has this form:

```
c:\...\smX\client>smcli 123.45.67.88 123.45.67.89  
-c "clear storageArray configuration;"
```

This command has two parameters that you can use to limit the amount of configuration information removed:

- **all** – Removes the entire configuration of the storage array, including security information and identification information. Removing all of the configuration information returns the storage array to its initial state.
- **volumeGroups** – Removes the volume configuration and the volume group configuration, but leaves the rest of the configuration intact.

If you want to create new volume groups and volumes within the storage array, you can use the `clear storageArray configuration` command with the `volumeGroups` parameter to remove existing volume groups in a pre-existing configuration. This action destroys the pre-existing configuration. Use the `clear storageArray configuration` command only when you create a new configuration.

Using the Auto Configure Command

The `autoConfigure storageArray` command creates the volume groups on a storage array, the volumes in the volume groups, and the hot spares for the storage array. When you use the `autoConfigure storageArray` command, you define these parameters:

- The type of drives (Fibre, SATA, or SAS)
- The RAID level
- The number of drives in a volume group
- The number of volume groups
- The number of volumes in each volume group
- The number of hot spares
- The size of each segment on the drives
- A read ahead multiplier

After you define these parameters, the SANtricity ES Storage Manager software creates the volume groups, the volumes, and the hot spares. The controllers assign volume group numbers and volume numbers as they are created. After the SANtricity ES Storage Manager software creates the initial configuration, you can use the `set volume` command to define volume labels.

Before you run the `autoConfigure storageArray` command, run the `show storageArray autoConfigure` command. The latter command returns a list of parameter values that the SANtricity ES Storage Manager software uses to automatically create a storage array. If you would like to change any of the parameter values, you can do so by entering new values for the parameters when you run the `autoConfigure storageArray` command. If you are satisfied with the parameter values that the `show storageArray autoConfiguration` command returns, run the `autoConfigure storageArray` command without new parameter values.

The `autoConfigure storageArray` command has this form:

When you use the `autoConfigure storageArray` command, two symbol functions (`getAutoConfigCandidates` and `createAutoConfig`) are used that let the client retrieve default settings for the various automatic configuration parameters, change the settings, query what the results of those changes would be and, finally, apply the desired parameters to create a configuration. The configurability portion of this feature provides enhancements to the automatic volume group creation algorithms, which produce volume groups with improved performance and more information about drive and volume attributes so the user can make better choices when configuring volumes manually.

The `volumeGroupWidth` parameter defines the number of unassigned drives that you want to use for each new volume group.

The `volumeGroupCount` parameter defines the number of new volume groups that you want in the storage array.

The `volumesPerGroupCount` parameter defines the number of volumes that you want in each volume group.

The `hotSpareCount` parameter defines the number of hot spares that you want in each volume group.

The `segmentSize` parameter defines the amount of data, in KB, that the controller writes on a single drive in a volume before writing data on the next drive. The smallest units of storage are data blocks. A data block stores 512 bytes of data. The size of a segment determines how many data blocks that it contains. An 8-KB segment holds 16 data blocks. A 64-KB segment holds 128 data blocks.

 **IMPORTANT** For optimal performance in a multiuser database or file system storage environment, set the segment size to minimize the number of drives that are needed to satisfy an I/O request.

Using a single drive for a single request leaves other drives available to simultaneously service other requests. Valid segment size values are 8, 16, 32, 64, 128, 256, and 512.

 **NOTE** If you set the cache block size to 16, you cannot create a volume with a segment size of 8.

If the volume is for a single user with large I/O requests (such as multimedia), performance is maximized when a single I/O request can be serviced with a single data stripe. A data stripe is the segment size multiplied by the number of drives in the volume group that are used for data storage. In this environment, multiple drives are used for the same request, but each drive is accessed only once.

The `cacheReadPrefetch` parameter turns on or turns off the ability of the controller to read additional data blocks into the cache. When you turn on cache read prefetch, the controller copies additional data blocks into the cache while it is reading requested data blocks from a drive into the cache. This action increases the chance that a future request for data can be fulfilled from the cache, which improves the speed with which data is accessed. The number of additional data blocks that the controller reads into the cache is determined by the configuration settings for the storage array that you use. Cache read prefetch is important for applications that use sequential I/O, such as multimedia applications.

Valid values for the `cacheReadPrefetch` parameter are **TRUE** or **FALSE**. If you want to turn on cache read prefetch, set the `cacheReadPrefetch` parameter to **TRUE**. If you want to turn off cache read prefetch, set the `cacheReadPrefetch` parameter to **FALSE**.

The following table lists the default values for the segment size and cache read prefetch settings for different storage array uses.

Default Values for Segment Size and Cache Read Prefetch

| Storage Array Use | Segment Size (KB) | Cache Read Prefetch |
|-------------------|-------------------|---------------------|
| File system | 128 | TRUE |
| Database | 128 | TRUE |
| Multimedia | 256 | TRUE |

Use the `securityType` parameter when you have `security#capable` drives that can support the SafeStore Drive Security premium feature. This parameter enables you to specify the security level when you create the volume group that uses the `security#capable` drives. The settings for the `securityType` parameter are:

- **none** – The volume group and volumes are not secure.
- **capable** – The volume group and volumes are capable of having security set, but security has not been enabled.

- **enabled** – The volume group and volumes have security enabled.

After you have finished creating the volume groups and the volumes by using the **autoConfigure storageArray** command, you can further define the properties of the volumes in a configuration by using the **set volume** command.

Example of the Auto Configuration Command

```
c:\...\smX\client>smcli 123.45.67.88 123.45.67.89
-c "autoConfigure storageArray driveType=fibre
raidLevel=5 volumeGroupWidth=8 volumeGroupCount=3
volumesPerGroupCount=4 hotSpareCount=2
segmentSize=8 cacheReadPrefetch=TRUE;"
```

The command in this example creates a storage array configuration by using Fibre Channel drives set to RAID Level 5. Three volume groups are created, and each volume group consists of eight drives, which are configured into four volumes. The storage array has two hot spares. The segment size for each volume is 8 KB. The cache read prefetch is turned on, which causes additional data blocks to be written into the cache.

Using the Create Volume Command

Use the **create volume** command to create new storage array volumes in three ways:

- Create a new volume while simultaneously creating a new volume group to which you assign the drives
- Create a new volume while simultaneously creating a new volume group to which the storage management software assigns the drives
- Create a new volume in an existing volume group

You must have unassigned drives in the volume group. You do not need to assign the entire capacity of the volume group to a volume.

Creating Volumes with User-Assigned Drives

When you create a new volume and assign the drives you want to use, the storage management software creates a new volume group. The controller firmware assigns a volume group number to the new volume group. The command has this form:

```
create volume drives=(trayID1, slotID1... trayIDn, slotIDn)
raidLevel=(0 | 1 | 3 | 5 | 6) userLabel="volumeName"
[volumeGroup=[volumeGroupName]
capacity=volumeCapacity owner=(a | b)
cacheReadPrefetch=(TRUE | FALSE)
segmentSize=segmentSizeValue
trayLossProtect=(TRUE | FALSE)]
```



NOTE The **capacity** parameter, the **owner** parameter, the **cacheReadPrefetch** parameter, the **segmentSize** parameter, the **trayLossProtect** parameter, the **drawerLossProtect** parameter, the **dssPreAllocate** parameter, and the **securityType** parameter are optional parameters (indicated by the placement inside the square brackets). You can use one or all of the optional parameters as needed to define your configuration. If you choose not to use any of the optional parameters, the default values of the parameters are used for your configuration.

The `userLabel` parameter is the name that you want to give to the volume. The volume name can be any combination of alphanumeric characters, hyphens, and underscores. The maximum length of the volume name is 30 characters. You must enclose the volume name with double quotation marks (" ").

The `drives` parameter is a list of the drives that you want to use for the volume group. Enter the tray ID and the slot ID of each drive that you want to use. Enclose the list in parentheses, separate the tray ID value and the slot ID value of a drive with a comma, and separate each tray ID and slot ID pair with a space. This example shows you how to enter tray ID values and slot ID values:

```
(1,1 1,2 1,3 1,4 1,5)
```

The `capacity` parameter defines the size of the volume. You do not need to assign the entire capacity of the drives to the volume. Later, you can assign any unused space to another volume.

The `owner` parameter defines the controller to which you want to assign the volume. If you do not specify a controller, the controller firmware determines the volume owner.

The `cacheReadPrefetch` parameter and the `segmentSize` parameter are the same as those described for the `autoConfigure storageArray` command.

The `trayLossProtect` parameter turns on or turns off tray loss protection for the volume group. (For a description of how tray loss protection works, see the topic "[Tray Loss Protection](#).")

Example of Creating Volumes with User-Assigned Drives

```
c:\...\smX\client>smcli 123.45.67.88 123.45.67.89
-c "create volume drives=(1,1 1,2 1,3 2,1 2,2 2,3)
raidLevel=5 userLabel=\"Engineering_1\" capacity=20GB
owner=a cacheReadPrefetch=TRUE segmentSize=128;"
```

The command in this example automatically creates a new volume group and a volume with the name `Engineering_1`. The volume group uses RAID Level 5. The command uses six drives to construct the volume group. The capacity of the volume will be 20 GB, which is distributed across all six drives. If each drive has a capacity of 73 GB, the total capacity of all the assigned disks is 438 GB.

```
73 GB x 6 drives = 438 GB
```

Because only 20 GB is assigned to the volume, 418 GB remains available (as unconfigured capacity) for other volumes that a user can add to this volume group later.

```
438 GB - 20 GB volume group size = 418 GB
```

Cache read prefetch is turned on, which causes additional data blocks to be written into the cache. The segment size for each volume is 128 KB. Tray loss protection is set to `TRUE`, which prevents any operation to drives in the drive tray if the drive tray fails. Hot spares are not created for this new volume group. You must create hot spares after you run this command.

Creating Volumes with Software-Assigned Drives

If you choose to let the storage management software assign the drives when you create the volume, you need only to specify the number of drives that you want to use. The storage management software then assigns the drives. The controller firmware assigns a volume group number to the new volume group. To manually create volume groups and volumes, use the `create volume` command:

```
create volume driveCount=numberOfDrives
raidLevel=(0 | 1 | 3 | 5 | 6) userLabel=volumeName
```

```
[driveType=(fibre | SATA | SAS | PATA)]
[capacity=volumeCapacity | owner=(a | b) |
cacheReadPrefetch=(TRUE | FALSE) |
segmentSize=segmentSizeValue]
[trayLossProtect=(TRUE | FALSE)]
```

This command is similar to the previous **create volume** command in which users assign the drives. The difference between this command and the previous one is that this version of the command requires only the number and the type of drives you want to use in the volume group. You do not need to enter a list of drives. All of the other parameters are the same. Tray loss protection is performed differently when the storage management software assigns the drives than when a user assigns the drives. (For a description of the difference, see the topic "[Tray Loss Protection](#).")

Example of Creating Volumes with Software-Assigned Drives

```
c:\...\smX\client>smcli 123.45.67.88 123.45.67.89
-c "create volume driveCount=6 raidLevel=5
userLabel=\"Engineering_1\"
capacity=20GB owner=a cacheReadPrefetch=TRUE segmentSize=128;"
```

The command in this example creates the same volume as the example for the previous **create volume** command in which a user assigns the drives. The difference is that a user does not know which drives are assigned to this volume group.

Creating Volumes in an Existing Volume Group

If you want to add a new volume to an existing volume group, use this command:

```
create volume volumeGroup=volumeGroupNumber
userLabel=volumeName
[freeCapacityArea=freeCapacityIndexNumber |
capacity=volumeCapacity | owner=(a | b) |
cacheReadPrefetch=(TRUE | FALSE) |
segmentSize=segmentSizeValue]
```



NOTE Parameters wrapped in square brackets or curly brackets are optional. You can use one or all of the optional parameters as needed to define your configuration. If you choose not to use any of the optional parameters, the default values of the parameter are provided for your configuration.

The `volumeGroup` parameter is the number of the volume group in which you want to create a new volume. If you do not know the volume group numbers on the storage array, you can use the **show allVolumes summary** command to get a list of the volumes and the volume groups to which the volumes belong.

The `userLabel` parameter is the name that you want to give to the volume. The volume name can be any combination of alphanumeric characters, hyphens, and underscores. The maximum length of the volume name is 30 characters. You must enclose the volume name with double quotation marks (" ").

The `freeCapacityArea` parameter defines the free capacity area to use for the volume. If a volume group has several free capacity areas, you can use this parameter to identify which free capacity area to use for volume creation. You do not have to assign the entire capacity of the drives to the volume. Later, you can assign any unused space to another volume.

The usage of the `capacity` parameter, the `owner` parameter, the `cacheReadPrefetch` parameter, and the `segmentSize` parameter is the same as described in the previous examples of the `create volume` command.

Tray Loss Protection

The `trayLossProtect` parameter is a boolean switch that you set to turn on or turn off tray loss protection. For tray loss protection to work, each drive in a volume group must be on a separate tray. The way in which tray loss protection works depends on the method that you choose to assign the drives for a volume group.

When you assign the drives, if you set `trayLossProtect=TRUE` and have selected more than one drive from any one tray, the storage array returns an error. If you set `trayLossProtect=FALSE`, the storage array performs operations, but the volume group that you create does not have tray loss protection.

When the controller firmware assigns the drives, if `trayLossProtect=TRUE`, the storage array posts an error if the controller firmware cannot provide drives that result in the new volume group having tray loss protection. If `trayLossProtect=FALSE`, the storage array performs the operation even if it means that the volume group might not have tray loss protection.

Tray loss protection is not valid when creating volumes on existing volume groups.

Modifying Your Configuration

For most configurations, after you have created your initial configuration by using the `autoConfigure storageArray` command or the `create volume` command, you must modify the properties of your configuration to make sure that it performs to meet the requirements for data storage. Use the `set` commands to modify a storage array configuration. This section describes how to modify these properties:

- The controller clocks
- The storage array password
- The storage array host type
- The storage array cache
- The global hot spares

Setting the Controller Clocks

To synchronize the clocks on the controllers with the host, use the `set storageArray time` command. Run this command to make sure that event time stamps that are written by the controllers to the Event Log match the event time stamps that are written to the host log files. The controllers stay available during synchronization. This example shows the command:

```
c:\...\smX\client>smcli 123.45.67.88 123.45.67.89
-c "set storageArray time;"
```

Setting the Storage Array Password

Use the `set storageArray` command to define a password for a storage array. The command has this form:

```
set storageArray password="password"
```

The `password` parameter defines a password for the storage array. Passwords provide added security to a storage array to help reduce the possibility of implementing destructive commands.



ATTENTION Possible data corruption or data loss – Implementing destructive commands can cause serious damage, including data loss.

Unless you define a password for the storage array, you can run all of the script commands. A password protects the storage array from any command that the controllers consider destructive. A destructive command is any command that can change the state of the storage array, such as volume creation; cache modification; or reset, delete, rename, or change commands.

If you have more than one storage array in a storage configuration, each storage array has a separate password. Passwords can have a maximum length of 30 alphanumeric characters. You must enclose the password in double quotation marks (" "). This example shows how to use the **set storageArray** command to define a password:

```
c:\...\smX\client>smcli 123.45.67.88 123.45.67.89
-c "set storageArray password="1a2b3c4d5e";"
```

Setting the Storage Array Host Type

Use the **set storageArray** command to define the default host type. The command has this form:

```
set storageArray defaultHostType=(hostTypeName | hostTypeIdentifier)
```

The `defaultHostType` parameter defines how the controllers in the storage array will communicate with the operating system on undefined hosts that are connected to the storage array SAN. This parameter defines the host type only for data I/O activities of the storage array. This parameter does not define the host type for the management station. The operating system can be Windows, Linux, or Solaris.

For example, if you set the `defaultHostType` parameter to **Linux**, the controller communicates with any undefined host if the undefined host is running a Linux operating system. Typically, you would need to change the host type only when you are setting up the storage array. The only time that you might need to use this parameter is if you need to change how the storage array behaves relative to the hosts that are connected to it.

Before you can define the default host type, you need to determine what host types are connected to the storage array. To return information about host types that are connected to the storage array, use the **show storageArray** command with the `defaultHostType` parameter or the `hostTypeTable` parameter. This command returns a list of the host types with which the controllers can communicate. This command does not return a list of the hosts. These examples show the use of the **show storageArray** command:

```
c:\...\smX\client>smcli 123.45.67.88 123.45.67.89
-c "show storageArray defaultHostType;"
```

```
c:\...\smX\client>smcli 123.45.67.88 123.45.67.89
-c "show storageArray hostTypeTable;"
```

This example shows how to define a specific default host type:

```
c:\...\smX\client>smcli 123.45.67.88 123.45.67.89
-c "set storageArray defaultHostType=11;"
```

The value **11** is the host type index value from the host type table that appears after entering the previous command.

Setting the Storage Array Cache

The cache is high-speed memory that holds data that is either written to the drives or read by the host. A controller has two memory areas that are used for intermediate storage of read data and write data. The read cache contains data that has been read from the drives but not yet transferred to the host. The write cache contains data from the host but not yet written to the drives.

The cache acts as a buffer so that data transfers between the host and the drive do not need to be synchronized. In read caching, the data for a read operation from the host might already be in the cache from a previous operation, which eliminates the need to access the drives. The data stays in the read cache until it is flushed. For write caching, a write operation stores data from the host in cache until it can be written to the drives.

The script command set provides two commands to define cache properties:

- **set storageArray**
- **set volume**

Use the **set storageArray** command to change the cache block size, the cache flush start value, and the cache stop value. The command has this form:

```
set storageArray cacheBlockSize=cacheBlockSizeValue |  
cacheFlushStart=cacheFlushStartSize |  
cacheFlushStop=cacheFlushStopSize
```

You can enter one, two, or all three of the parameters on the command line.

The cache block size value defines the size of the data block that is used by the controller in transferring data into or out of the cache. You can set the cache block size to either **4KB**, **8KB**, or **16KB**. The value that you use applies to the entire storage array and all of the volumes in the storage array. For redundant controller configurations, this value includes all volumes owned by both controllers. Use smaller cache block sizes for systems that require transaction processing requests or I/O streams that are typically small and random. Use larger cache block sizes for large I/O, sequential, high#bandwidth applications. The choice of block size affects read/write performance. Large data transfers take longer in 4-KB block sizes than 16-KB block sizes. This example shows how to set the `cacheBlockSize` parameter:

```
c:\...\smX\client>smcli 123.45.67.88 123.45.67.89  
-c "set storageArray cacheBlockSize=16;"
```

To prevent data loss or corruption, the controller periodically writes cache data to the drives (flushes the cache) when the amount of unwritten data in the cache reaches a predefined level, called a start percentage. The controller also writes cache data to the drives when data has been in the cache for a predetermined amount of time. The controller writes data to the drives until the amount of data in the cache drops to a stop percentage level. Use the **set storageArray** command to set the start value and the stop value as percentages of the filled capacity of the cache. For example, you can specify that the controller start flushing the cache when it reaches 80-percent full and stop flushing the cache when it reaches 16-percent full. This example shows how to set these parameters:

```
c:\...\smX\client>smcli 123.45.67.88 123.45.67.89  
-c "set storageArray cacheFlushStart=80 cacheFlushStop=16;"
```

Low start percentages and low stop percentages provide for maximum data protection. For both low start percentages and low stop percentages, the chance that data requested by a read command is not in the cache is increased. When the data is not in the cache, the cache hit percentage for writes and I/O requests

decreases. Low start values and low stop values also increase the number of writes that are necessary to maintain the cache level. Increasing the number of writes increases the system overhead and further decreases performance.

Use the `set volume` command to change settings for the cache flush modifier, cache without batteries enabled, mirror cache enabled, the read ahead multiplier, read cache enabled, and write cache enabled. Use this command to set properties for all of the volumes or for a specific volume in a volume group. The command has this form:

```
set (allVolumes | volume [volumeName] |
volumes [volumeName1 ... volumeNameN]
volume <wwID>) |
cacheFlushModifier=cacheFlushModifierValue |
cacheWithoutBatteryEnabled=(TRUE | FALSE) |
mirrorCacheEnabled=(TRUE | FALSE) |
readCacheEnabled=(TRUE | FALSE) |
writeCacheEnabled=(TRUE | FALSE) |
cacheReadPrefetch=(TRUE | FALSE)
```

The `cacheFlushModifier` parameter defines the amount of time that data stays in the cache before it is written to the drives. The following table lists the values for the `cacheFlushModifier` parameter.

Values for the `cacheFlushModifier` Parameter

| Value | Meaning |
|------------------|---|
| Immediate | Data is flushed as soon as it is placed into the cache. |
| 250 | Data is flushed after 250 ms. |
| 500 | Data is flushed after 500 ms. |
| 750 | Data is flushed after 750 ms. |
| 1 | Data is flushed after 1 s. |
| 1500 | Data is flushed after 1500 ms. |
| 2 | Data is flushed after 2 s. |
| 5 | Data is flushed after 5 s. |
| 10 | Data is flushed after 10 s. |
| 20 | Data is flushed after 20 s. |
| 60 | Data is flushed after 60 s (1 min.). |
| 120 | Data is flushed after 120 s (2 min.). |
| 300 | Data is flushed after 300 s (5 min.). |
| 1200 | Data is flushed after 1200 s (20 min.). |
| 3600 | Data is flushed after 3600 s (1 hr.). |

| Value | Meaning |
|-----------------|---|
| Infinite | Data in cache is not subject to any age or time constraints. The data is flushed based on other criteria managed by the controller. |

This example shows how to set this parameter value for all of the volumes in the storage array:

```
c:\...\smX\client>smcli 123.45.67.88 123.45.67.89
-c "set allvolumes cacheFlushModifier=10;"
```



IMPORTANT Do not set the value of the `cacheFlushModifier` parameter above 10 seconds. An exception is for testing purposes. After running any tests in which you have set the values of the `cacheFlushModifier` parameter above 10 seconds, return the value of the `cacheFlushModifier` parameter to 10 or fewer seconds.

The `cacheWithoutBatteryEnabled` parameter turns on or turns off the ability of a host to perform write caching without backup batteries in a controller. To enable write caching without batteries, set this parameter to **TRUE**. To disable write caching without batteries, set this parameter to **FALSE**. If you set this parameter to **TRUE**, write caching continues, even when the controller batteries are completely discharged, not fully charged, or not present. If you do not have an uninterruptible power supply (UPS) and you enable this parameter, you can lose data if power to the storage array fails. This example shows how to set this parameter value:

```
c:\...\smX\client>smcli 123.45.67.88 123.45.67.89
-c "set volume [\"Engineering\"]
cacheWithoutBatteryEnabled=FALSE;"
```

The `mirrorCacheEnabled` parameter turns on or turns off write caching with mirroring. Write caching with mirroring permits cached data to be mirrored across redundant controllers that have the same cache size. Data written to the cache memory of one controller also is written to the cache memory of the second controller. If one controller fails, the second controller can complete all outstanding write operations. To use this option, these conditions must exist:

- The controller pair must be an active/active pair.
- The controllers must have the same size cache.

To enable write caching with mirroring, set this parameter to **TRUE**. To disable write caching with mirroring, set this parameter to **FALSE**. This example shows how to set this parameter:

```
c:\...\smX\client>smcli 123.45.67.88 123.45.67.89
-c "set volume [\"Accounting\"] mirrorCacheEnabled=TRUE;"
```

The `readCacheEnabled` parameter turns on or turns off the ability of the host to read data from the cache. Read caching enables read operations from the host to be stored in controller cache memory. If a host requests data that is not in the cache, the controller reads the needed data blocks from the drives and places them in the cache. Until the cache is flushed, all of the other requests for this data are fulfilled with cache data rather than from a read, which increases throughput. To enable read caching, set this parameter to **TRUE**. To disable read caching, set this parameter to **FALSE**. This example shows how to set this parameter:

```
c:\...\sm9\client>smcli 123.45.67.88 123.45.67.89
-c "set volume [\"Balance_04\"] readCacheEnabled=TRUE;"
```

The `writeCacheEnabled` parameter turns on or turns off the ability of the host to write data to the cache. Write caching enables write operations from the host to be stored in cache memory. The volume data in the cache is automatically written to the drives every 10 seconds. To enable write caching, set this parameter to **TRUE**. To disable write caching, set this parameter to **FALSE**. This example shows how to set this parameter:

```
c:\...\smX\client>smcli 123.45.67.88 123.45.67.89
-c "set allVolumes writeCacheEnabled=TRUE;"
```

The `cacheReadPrefetch` parameter turns on or turns off the ability of the controller to read additional data blocks into cache. When you turn on cache read prefetch, the controller copies additional data blocks into cache while it is reading requested data blocks from a drive into cache. This action increases the chance that a future request for data can be fulfilled from the cache, which improves the speed with which data is accessed. The number of additional data blocks that the controller reads into cache is determined by the storage array configuration settings that you use. Cache read prefetch is important for applications that use sequential I/O, such as multimedia applications.

Valid values for the `cacheReadPrefetch` parameter are **TRUE** or **FALSE**. If you want to turn on cache read prefetch, set the `cacheReadPrefetch` parameter to **TRUE**. If you want to turn off cache read prefetch, set the `cacheReadPrefetch` parameter to **FALSE**. This example shows how to set this parameter:

```
c:\...\smX\client>smcli 123.45.67.88 123.45.67.89
-c "set volume [\"Engineering_1\" \"Engineering_2\"]
cacheReadPrefetch=TRUE;"
```

Setting the Modification Priority

Modification priority defines how much processing time is allocated for volume modification operations. Time allocated for volume modification operations affects system performance. Increases in volume modification priority can reduce read/write performance. The modification priority affects these operations:

- Copyback
- Reconstruction
- Initialization
- Changing the segment size
- Defragmentation of a volume group
- Adding free capacity to a volume group
- Changing the RAID level of a volume group

The lowest priority rate favors system performance, but the modification operation takes longer. The highest priority rate favors the modification operation, but the system performance might be degraded.

Use the **set volume** command to define the modification priority for a volume. The command has this form:

```
set (allVolumes | volume [volumeName] |
volumes [volumeName1 ... volumeNameN] volume <wwID> |
accessVolume)
modificationPriority=(highest | high | medium | low | lowest)
```

This example shows how to use this command to set the modification priority for volumes named `Engineering_1` and `Engineering_2`:

```
c:\...\smX\client>smcli 123.45.67.88 123.45.67.89
-c "set volume [\"Engineering_1\" \"Engineering_2\"]
```

```
modificationPriority=lowest;"
```

The modification rate is set to **lowest** so that system performance is not significantly reduced by modification operations.

Assigning Global Hot Spares

You can assign or unassign global hot spares by using the **set drive** command. To use this command, you must identify the location of the drives by the tray ID and the slot ID. Then, you set the `hotSpare` parameter to **TRUE** to enable the hot spare or **FALSE** to disable an existing hot spare. The command has this form:

```
set (drive [trayID,slotID] | drives
[trayID1,slotID1 ... trayIDn,slotIDn]) hotSpare=(TRUE | FALSE)
```

This example shows how to set hot spare drives:

```
c:\...\smX\client>smcli 123.45.67.88 123.45.67.89
-c "set drives [1,2 1,3] hotSpare=TRUE;"
```

Enter the tray ID and the slot ID of each drive that you want to use. Enclose the list in square brackets, separate the tray ID value and the slot ID value of a drive with a comma, and separate each tray ID and slot ID pair with a space.

Saving a Configuration to a File

After you have created a new configuration or if you want to copy an existing configuration for use on other storage arrays, you can save the configuration to a file by using the **save storageArray configuration** command. Saving the configuration creates a script file that you can run on the command line. The command has this form:

```
save storageArray configuration file="filename"
[(allconfig | globalSettings=(TRUE | FALSE)) |
volumeConfigAndSettings=(TRUE | FALSE) |
hostTopology=(TRUE | FALSE) | lunMappings=(TRUE | FALSE)]
```



ATTENTION Possible loss of data – When information is written to a file, the script engine does not check to determine if the file name already exists. If you choose the name of a file that already exists, the script engine writes over the information in the file without warning.

You can choose to save the entire configuration or specific configuration features. This example shows how to set this parameter value:

```
c:\...\smX\client>smcli 123.45.67.88 123.45.67.89
-c "save storagearray configuration
file=\"c:\\folder\\storagearrayconfig1.scr\";"
```

In this example, the name `folder` is the folder in which you want to place the profile file and `storagearrayconfig1.scr` is the name of the file. You can choose any folder and any file name. The file extension for a configuration file is `.scr`. The storage management software uses this extension when it creates the configuration file.

Using the Snapshot Premium Feature

The Snapshot premium feature creates a snapshot volume that you can use as a backup of your data. A snapshot volume is a logical point-in-time image of a standard volume. Because it is not a physical copy, a snapshot volume is created more quickly than a physical copy and requires less storage space on the drive. Typically, you create a snapshot volume so that an application, such as a backup application, can access the snapshot volume and read the data while the base volume stays online and user accessible. You can also create several snapshot volumes of a base volume and write data to the snapshot volumes to perform testing and analysis.

Snapshot volumes provide these capabilities:

- Create a complete image of the data on a base volume at a particular point in time
- Use only a small amount of storage space
- Provide for quick, frequent, non-disruptive backups, or testing new versions of a database system without affecting real data
- Provide for snapshot volumes to be read, written, and copied
- Use the same availability characteristics of the base volume (such as RAID protection and redundant path failover)
- Map the snapshot volume and make it accessible to any host on a storage area network (SAN). You can make snapshot data available to secondary hosts for read access and write access by mapping the snapshot to the hosts
- Create up to 16 snapshots per volume and up to 1024 snapshots per storage array. The maximum number of snapshots depends on the model of the controller. The maximum number of snapshot volumes is one-half of the total number of volumes that are supported by the controller.
- Increase the capacity of a snapshot volume

How Snapshot Works

Three components comprise a snapshot volume: the base volume, the snapshot volume, and the snapshot repository volume. The following table lists the components and briefly describes what they do.

Components of a Snapshot Volume

| Component | Description |
|----------------------------|--|
| Base volume | A standard volume from which the snapshot is created |
| Snapshot volume | A logical point-in-time image of a standard volume |
| Snapshot repository volume | A volume that contains snapshot metadata and copy-on-write data for a particular snapshot volume |

Based on information that you provide through the script commands, the storage management software creates an empty snapshot repository volume and defines the mapping from a base volume to the snapshot repository volume. The snapshot repository volume holds changed data that a host writes to the base volume. When the snapshot repository volume is first created, it holds only the metadata about the snapshot volume with which it is associated.



NOTE When you first create a snapshot repository volume, briefly stop all of the write operations to the base volume so that a stable image of the base volume is available.

When the host writes to the base volume, the new data is also copied to the snapshot repository volume. This action is called copy-on-write. A snapshot is constructed by combining the updated data in the snapshot repository volume with data in the base volume that has not been altered. This action creates a complete copy of the base volume at a specific point in time. The snapshot appears as a volume that contains the original data at the time of creation, but the snapshot is actually an image that is the combination of the snapshot repository volume and the original base volume. The snapshot repository volume, which houses original data that has been changed, is the only additional drive space that is needed for the snapshot volume. The additional drive space is typically 10 percent to 20 percent of the drive space of the base volume and varies depending on the amount of changes to the data. The longer a snapshot volume is active, the larger the snapshot repository volume must be. The default size of the snapshot repository volume is 20 percent of the base volume; however, you can set the size of the snapshot repository volume to other values.

You can read, write, and copy a snapshot volume. Data written by a host to the snapshot volume is handled in the snapshot repository volume. When a write occurs to the base volume of a snapshot volume, the new data also overwrites the appropriate snapshot repository volume data.

Snapshot Volume Commands

| Command | Description |
|---|--|
| <code>create snapshotVolume</code> | This command creates a snapshot volume. |
| <code>recreate snapshot</code> | This command starts a fresh copy-on-write operation by using an existing snapshot volume. |
| <code>recreate snapshot collection</code> | This command restarts multiple snapshot volumes as one batch operation by using one or many existing snapshot volumes. |
| <code>set (snapshotVolume)</code> | This command defines the properties for a snapshot volume and lets you rename a snapshot volume. |
| <code>stop snapshot</code> | This command stops a copy-on-write operation. |

Creating a Snapshot Volume

The `create snapshotVolume` command provides three methods for defining the drives for your snapshot repository volume:

- Defining the drives for the snapshot repository volume by their tray IDs and their slot IDs.
- Defining a volume group in which the snapshot repository volume resides. In addition, you can define the capacity of the snapshot repository volume.
- Defining the number of drives, but not specific drives, for the snapshot repository volume.

When you use the `create snapshotVolume` command to create a snapshot volume, the minimum information that you need to provide is the standard volume that you want to use for the base volume. When you create a snapshot volume by using minimum information, the storage management software provides default values for the other property parameters that are required for a completely defined snapshot volume.

Creating a Snapshot Volume with User-Assigned Drives

Creating a snapshot volume by assigning the drives provides flexibility in defining your configuration by letting you choose from the available drives in your storage array. When you choose the drives for your snapshot volume, you automatically create a new volume group. You can specify which drives to use and the RAID level for the new volume group. The command has this form:

```
create snapshotVolume baseVolume="baseVolumeName"
[repositoryRAIDLevel=(1 | 3 | 5 | 6)
(repositoryDrives=(trayID1,slotID1 ... trayIDn,slotIDn)
userLabel="snapshotVolumeName"
warningThresholdPercent=percentValue
repositoryPercentOfBase=percentValue
repositoryUserLabel="repositoryName"
repositoryFullPolicy=(failBaseWrites | failSnapShot)]
[trayLossProtect=(TRUE | FALSE)]
```

This example shows a command in which users assign the drives:

```
c:\...\smX\client>smcli 123.45.67.88 123.45.67.89
-c "create snapshotVolume baseVolume=\"Mars_Spirit_4\"
repositoryRAIDLevel=5 repositoryDrives=(1,1 1,2 1,3 1,4 1,5);"
```

The command in this example creates a new snapshot of the base volume `Mars_Spirit_4`. The snapshot repository volume consists of five drives that form a new volume group. The new volume group has RAID Level 5. This command also takes a snapshot of the base volume, which starts the copy-on-write operation.

This example shows how to use the command in a script file:

```
create snapshotVolume baseVolume="Mars_Spirit_4" repositoryRAIDLevel=5
repositoryDrives=(1,1 1,2 1,3 1,4 1,5);
```

This example shows a minimal version of the command:

```
c:\...\smX\client>smcli 123.45.67.88 123.45.67.89
-c "create snapshotVolume baseVolume=\"Mars_Spirit_4\";"
```

The command in this example creates a new snapshot for the base volume `Mars_Spirit_4`. The snapshot repository volume is created in the same volume group as the base volume, which means that the snapshot repository volume has the same RAID level as the base volume. This command starts the copy-on-write operation.

This example shows how to use the command in a script file:

```
create snapshotVolume baseVolume="Mars_Spirit_4";
```

Creating a Snapshot Volume with Software-Assigned Drives

With this version of the **create snapshotVolume** command, you choose an existing volume group in which to place the snapshot repository volume. The storage management software determines which drives to use. You can also define how much space to assign to the snapshot repository volume. Because you are using an existing volume group, the RAID level for the snapshot volume defaults to the RAID level of the volume group in which you place it. You cannot define the RAID level for the snapshot volume. The command has this form:

```
create snapshotVolume baseVolume="baseVolumeName"
[repositoryVolumeGroup=volumeGroupName
freeCapacityArea=freeCapacityIndexNumber
userLabel="snapshotVolumeName"
warningThresholdPercent=percentValue
repositoryPercentOfBase=percentValue
repositoryUserLabel=repositoryName
repositoryFullPolicy=(failBaseWrites | failSnapShot)]
[trayLossProtect=(TRUE | FALSE)]
```

This example shows a command in which the storage management software assigns the drives:

```
c:\...\smX\client>smcli 123.45.67.88 123.45.67.89
-c "create snapshotVolume baseVolume=\"Mars_Spirit_4\"
repositoryVolumeGroup=2 freeCapacityArea=2;"
```

The command in this example creates a new snapshot repository volume in volume group 2. The base volume is `Mars_Spirit_4`. The size of the snapshot repository volume is 4 GB. This command also takes a snapshot of the base volume, starting the copy-on-write operation.

When you define the capacity of a snapshot repository volume, specify a size that is 20 percent of the size of the base volume. In the previous example, the size of the snapshot repository volume is set to 4 GB. The underlying assumption is that the base volume size is 20 GB (0.2 x 20 GB = 4 GB).

This example shows how to use the command in a script file:

```
create snapshotVolume baseVolume="Mars_Spirit_4"
repositoryVolumeGroup=2 freeCapacityArea=2;
```

Creating a Snapshot Volume by Specifying a Number of Drives

With this version of the **create snapshotVolume** command, you must specify the number of drives and the RAID level that you want for the snapshot repository volume. This version of the **create snapshotVolume** command creates a new volume group. You must have drives in the storage array that are not assigned to a volume group for this command to work.

```
create snapshotVolume baseVolume="baseVolumeName"
[repositoryRAIDLevel=(1 | 3 | 5 | 6)
repositoryDriveCount=numberOfDrives
driveType=(fibre | SATA | SAS)
userLabel="snapshotVolumeName"
warningThresholdPercent=percentValue
repositoryPercentOfBase=percentValue
repositoryUserLabel="repositoryName"
repositoryFullPolicy=(failBaseWrites | failSnapShot)]
[trayLossProtect=(TRUE | FALSE)]
```

This example shows how to use a command in which users specify the number of drives:

```
c:\...\smX\client>smcli 123.45.67.88 123.45.67.89
-c "create snapshotVolume baseVolume=\"Mars_Spirit_4\"
repositoryRAIDLevel=5 repositoryDriveCount=3;"
```

The command in this example creates a new snapshot repository volume that consists of three drives. Three drives comprise a new volume group that has RAID Level 5. This command also takes a snapshot of the base volume, which starts the copy-on-write operation.

This example shows how to use the command in a script file:

```
create snapshotVolume baseVolume= "Mars_Spirit_4"
repositoryRAIDLevel=5 repositoryDriveCount=3;
```

User-Defined Parameters

Use the parameters in the **create snapshotVolume** command to define the snapshot volume to suit the requirements of your storage array. The following table lists the parameters and briefly describes what the parameters do.

Snapshot Volume Parameters

| Parameter | Description |
|-----------------------|---|
| driveType | The type of drive that you want to use for the snapshot repository volume. The choice is fibre (Fibre Channel), SATA , or SAS . This parameter works only with the count-based repository method of defining a snapshot volume. |
| repositoryVolumeGroup | The volume group in which you want to build the snapshot repository volume. The default value is to build the snapshot repository volume in the same volume group as the base volume. |
| freeCapacityArea | The amount of storage space that you want to use for the snapshot repository volume. Free storage space is defined in units of bytes, KB, MB, GB, or TB. |
| userLabel | The name that you want to give to the snapshot volume. If you do not choose a name for the snapshot volume, the software creates a default name by using the base volume name. For example, with a base volume name of Mars_Spirit_4: <ul style="list-style-type: none"> ▪ When the base volume does not have a snapshot volume, the default snapshot volume name is Mars_Spirit_4-1. ▪ When the base volume already has $n-1$ number of snapshot volumes, the default name is Mars_Spirit_4-n. |

| Parameter | Description |
|-------------------------|---|
| repositoryUserLabel | The name that you want to give to the snapshot repository volume. If you do not choose a name for the snapshot repository volume, the software creates a default name by using the base volume name. For example, if the base volume name is Mars_Spirit_4 and does not have an associated snapshot repository volume, the default snapshot repository volume name is Mars_Spirit_4-R1. If the base volume already has <i>n-1</i> number of snapshot repository volumes, the default name is Mars_Spirit_4-R <i>n</i> . |
| warningThresholdPercent | The percentage of the capacity that you will permit the snapshot repository volume to get before you receive a warning that the snapshot repository volume is nearing full. The warning value is a percentage of the total capacity of the snapshot repository volume. The default value is 50, which represents 50 percent of the total capacity. (You can change this value later by using the <code>set snapshotVolume</code> command.) |
| repositoryPercentOfBase | The size of the snapshot repository volume as a percentage of the base volume size. The default value is 20, which represents 20 percent of the base volume size. |
| repositoryFullPolicy | The type of snapshot processing that you want to continue if the snapshot repository volume is full. You can choose to fail writes to the base volume (<code>failBaseWrites</code>) or fail writes to the snapshot volume (<code>failSnapshot</code>). The default value is <code>failSnapshot</code> . |

This example shows the `create snapshotVolume` command that includes user-defined parameters:

```
c:\...\smX\client>smcli 123.45.67.88 123.45.67.89
-c "create snapshotVolume baseVolume=\"Mars_Spirit_4\"
repositoryRAIDLevel=5 repositoryDriveCount=5
driveType=fibre userLabel=\"Mars_Spirit_4_snap1\"
repositoryUserLabel=\"Mars_Spirit_4_rep1\"
warningThresholdPercent=75 repositoryPercentOfBase=40
repositoryFullPolicy=failSnapshot;"
```

This example shows how to use the command in a script file:

```
create snapshotVolume baseVolume="Mars_Spirit_4"
repositoryRAIDLevel=5 repositoryDriveCount=5 driveType=fibre
userLabel="Mars_Spirit_4_snap1"
repositoryUserLabel="Mars_Spirit_4_rep1"
warningThresholdPercent=75 repositoryPercentOfBase=40
repositoryFullPolicy=failSnapshot;
```

Snapshot Volume Names and Snapshot Repository Volume Names

The snapshot volume names and the snapshot repository volume names can be any combination of alphanumeric characters, hyphens, and underscores. The maximum length of the volume names is 30 characters. You must enclose the volume name in double quotation marks. The character string cannot contain a new line. Make sure that you use unique names; if you do not use unique names, the controller firmware returns an error.

One technique for naming the snapshot volume and the snapshot repository volume is to add a hyphenated suffix to the original base volume name. The suffix distinguishes between the snapshot volume and the snapshot repository volume. For example, if you have a base volume with a name of Engineering Data, the snapshot volume can have a name of Engineering Data-S1, and the snapshot repository volume can have a name of Engineering Data-R1.

If you do not choose a unique name for either the snapshot volume or the snapshot repository volume, the controllers create a default name by using the base volume name. These examples are snapshot volume names that the controllers might create:

- If the base volume name is *aaa* and does not have a snapshot volume, the default snapshot volume name is *aaa1*.
- If the base volume already has *n-1* number of snapshot volumes, the default name is *aaa-n*.
- If the base volume name is *aaa* and does not have a snapshot repository volume, the default snapshot repository volume name is *aaa-R1*.
- If the base volume already has *n-1* number of snapshot repository volumes, the default name is *aaa-Rn*.

In the examples from the previous section, the user-defined snapshot volume name was *Mars_Spirit_4_snap1*, and the user-defined snapshot repository volume name was *Mars_Spirit_4_rep1*. The default name that was provided by the controller for the snapshot volume was *Mars_Spirit_4-1*. The default name that was provided by the controller for the snapshot repository volume was *Mars_Spirit_4-R1*.

Changing Snapshot Volume Settings

Use the **set (snapshot) volume** command to change these property settings for a snapshot volume:

- The snapshot volume name
- The warning threshold percent
- The snapshot repository full policy

This example shows how to change a snapshot volume name.

```
c:\...\smX\client>smcli 123.45.67.88 123.45.67.89
-c "set volume [\"Mars_Spirit_4-1\"]
userLabel= \"Mars_Odyssey_3-2\" ;"
```

This example shows how to use the command in a script file:

```
set volume [\"Mars_Spirit_4-1\"] userLabel= \"Mars_Odyssey_3-2\" ;
```

When you change the warning threshold percent and the snapshot repository full policy, you can apply the changes to one or several snapshot volumes with this command. This example shows how to use the **set (snapshot) volume** command to change these properties on more than one snapshot volume:

```
c:\...\smX\client>smcli 123.45.67.88 123.45.67.89
```

```
-c "set volume
[\"Mars_Spirit_4-1\" \"Mars_Spirit_4-2\" \"Mars_Spirit_4-3\"
warningThresholdPercent=50
repositoryFullPolicy=failBaseWrites;\"
```

This example shows how to use the command in a script file:

```
set volume [\"Mars_Spirit_4-1\" \"Mars_Spirit_4-2\"
\"Mars_Spirit_4-3\"] warningThresholdPercent=50
repositoryFullPolicy=failBaseWrites;
```

Stopping, Restarting, and Deleting a Snapshot Volume

When you create a snapshot volume, copy-on-write starts running immediately. As long as a snapshot volume is enabled, storage array performance is impacted by the copy-on-write operations to the associated snapshot repository volume.

If you no longer want copy-on-write operations to run, you can use the **stop snapshot volume** command to stop the copy-on-write operations. When you stop a snapshot volume, the snapshot volume and the snapshot repository volume are still defined for the base volume. Only copy-on-write has stopped. This example shows how to stop a snapshot volume:

```
c:\...\smX\client>smcli 123.45.67.88 123.45.67.89
-c "stop snapshot volumes
[\"Mars_Spirit_4-2\" \"Mars_Spirit_4-3\"];\"
```

This example shows how to use the command in a script file:

```
stop snapshot volumes
[\"Mars_Spirit_4-2\" \"Mars_Spirit_4-3\"];
```

When you stop the copy-on-write operations for a specific snapshot volume, only that snapshot volume is disabled. All of the other snapshot volumes stay in operation.

When you want to restart a copy-on-write operation, use the **recreate snapshot volume** command or the **recreate snapshot collection** command. The **recreate snapshot volume** command starts a fresh copy-on-write operation by using an existing snapshot volume.



NOTE The snapshot volume must be in either an Optimal state or a Disabled state.

When you restart a snapshot volume, these actions occur:

- All copy-on-write data previously on the snapshot repository volume is overwritten.
- Snapshot volume parameters and snapshot repository volume parameters stay the same as the previously disabled snapshot volume and the previously disabled snapshot repository volume. You can also change the `userLabel` parameter, the `warningThresholdPercent` parameter, and the `repositoryFullPolicy` parameter when you restart the snapshot volume.
- The original names for the snapshot repository volume are retained.

This example shows how to restart a snapshot volume:

```
c:\...\smX\client>smcli 123.45.67.88 123.45.67.89
-c "recreate snapshot volumes
[\"Mars_Spirit_4-2\" \"Mars_Spirit_4-3\"];\"
```

This example shows how to use the command in a script file:

```
recreate snapshot volumes  
["Mars_Spirit_4-2" "Mars_Spirit_4-3"];
```

If you do not intend to use a snapshot volume again, you can delete the snapshot volume by using the **delete volume** command. When you delete a snapshot volume, the associated snapshot repository volume also is deleted.

Using the Remote Volume Mirroring Premium Feature

The Remote Volume Mirroring premium feature provides for online, real-time replication of data between storage arrays over a remote distance. In the event of a disaster or a catastrophic failure on one storage array, you can promote the second storage array to take over responsibility for computing services. Remote Volume Mirroring is designed for extended storage environments in which the storage arrays that are used for Remote Volume Mirroring are maintained at separate sites. Volumes on one storage array are mirrored to volumes on another storage array across a fabric SAN. Data transfers can be synchronous or asynchronous. You choose the method when you set up the remote mirrored pair. The data transfers occur at Fibre Channel speeds to maintain data on the different storage arrays. Because Remote Volume Mirroring is storage based, it does not require any server overhead or application overhead.

You can use Remote Volume Mirroring for these functions:

- **Disaster recovery** – Remote Volume Mirroring lets you replicate data from one site to another site, which provides an exact duplicate at the remote (secondary) site. If the primary site fails, you can use mirrored data at the remote site for failover and recovery. You can then shift storage operations to the remote site for continued operation of all of the services that are usually provided by the primary site.
- **Data vaulting and data availability** – Remote Volume Mirroring lets you send data off site where it can be protected. You can then use the off-site copy for testing or to act as a source for a full backup to avoid interrupting operations at the primary site.
- **Two-way data protection** – Remote Volume Mirroring provides the ability to have two storage arrays back up each other by duplicating critical volumes on each storage array to volumes on the other storage array. This action lets each storage array recover data from the other storage array in the event of any service interruptions.

How Remote Volume Mirroring Works

When you create a remote-mirror pair, the remote-mirror pair consists of a primary volume on a local storage array and a secondary volume on a storage array at another site. A standard volume might only be included in one mirrored volume pair.

Maximum Number of Defined Mirrors per Storage Array

| Controller Model | Maximum Number of Defined Mirrors |
|--------------------------------|--|
| AM1331, AM1333, AM1532, AM1932 | Only supported in a co-existence storage environment |
| CE2600 | 16 |
| CDE3992, CDE3994 | 64 |
| CE4900 | 64 |
| CE6998, CE7900 | 128 |

The primary volume is the volume that accepts host I/O activity and stores application data. When the mirror relationship is first created, data from the primary volume is copied in its entirety to the secondary volume. This process is known as a full synchronization and is directed by the controller owner of the primary volume. During a full synchronization, the primary volume remains fully accessible for all normal I/O operations.

The controller owner of the primary volume initiates remote writes to the secondary volume to keep the data on the two volumes synchronized.

The secondary volume maintains a mirror (or copy) of the data on its associated primary volume. The controller owner of the secondary volume receives remote writes from the controller owner of the primary volume but will not accept host write requests. Hosts are able to read from the secondary volume, which appears as read-only.

In the event of a disaster or a catastrophic failure at the primary site, you can perform a role reversal to promote the secondary volume to a primary role. Hosts then are able to read from and write to the newly promoted volume, and business operations can continue.

Mirror Repository Volumes

A mirror repository volume is a special volume in the storage array that is created as a resource for the controller owner of the primary volume in a remote mirrored pair. The controller stores mirror information on this volume, including information about remote writes that are not yet complete. The controller can use this information to recover from controller resets and the accidental powering down of the storage arrays.

When you activate the Remote Volume Mirroring premium feature on the storage array, you create two mirror repository volumes, one for each controller in the storage array. An individual mirror repository volume is not needed for each remote mirror.

When you create the mirror repository volumes, you specify the location of the volumes. You can either use existing free capacity, or you can create a volume group for the volumes from unconfigured capacity and then specify the RAID level.

Because of the critical nature of the data being stored, do not use RAID Level 0 as the RAID level of mirror repository volumes. The required size of each volume is 128 MB, or 256 MB total for both mirror repository volumes of a dual-controller storage array. In previous versions of the Remote Volume Mirroring premium feature, the mirror repository volumes required less disk storage space and needed to be upgraded to use the maximum amount of mirror relationships.

Mirror Relationships

Before you create a mirror relationship, you must enable the Remote Volume Mirroring premium feature on both the primary storage array and the secondary storage array. You must also create a secondary volume on the secondary site if one does not already exist. The secondary volume must be a standard volume of equal or greater capacity than the associated primary volume.

When secondary volumes are available, you can establish a mirror relationship in the storage management software by identifying the primary volume and the storage array that contains the secondary volume.

When you first create the mirror relationship, a full synchronization automatically occurs, with data from the primary volume copied in its entirety to the secondary volume.

Data Replication

The controllers manage data replication between the primary volume and the secondary volume. This process is transparent to host machines and applications. This section describes how data is replicated between the storage arrays that are participating in Remote Volume Mirroring. This section also describes the actions taken by the controller owner of the primary volume if a link interruption occurs between storage arrays.

Write Modes

When the controller owner of the primary volume receives a write request from a host, the controller first logs information about the write to a mirror repository volume, and then writes the data to the primary volume. The controller then initiates a remote write operation to copy the affected data blocks to the secondary volume at the secondary storage array.

The Remote Volume Mirroring premium feature provides two write mode options that affect when the I/O completion indication is sent back to the host: Synchronous and Asynchronous.

Synchronous Write Mode

Synchronous write mode provides the highest level security for full data recovery from the secondary storage array in the event of a disaster. Synchronous write mode does reduce host I/O performance. When this write mode is selected, host write requests are written to the primary volume and then copied to the secondary volume. After the host write request has been written to the primary volume and the data has been successfully copied to the secondary volume, the controller removes the log record on the mirror repository volume. The controller then sends an I/O completion indication back to the host system. Synchronous write mode is selected as the default value and is the recommended write mode.

Asynchronous Write Mode

Asynchronous write mode offers faster host I/O performance but does not guarantee that a copy operation has successfully completed before processing the next write request. When you use Asynchronous write mode, host write requests are written to the primary volume. The controller then sends an "I/O complete" indication back to the host system, without acknowledging that the data has been successfully copied to the secondary (remote) storage array.

When using Asynchronous write mode, write requests are not guaranteed to be completed in the same order on the secondary volume as they are on the primary volume. If the order of write requests is not retained, data on the secondary volume might become inconsistent with the data on the primary volume. This event could jeopardize any attempt to recover data if a disaster occurs on the primary storage array.

Write Consistency Mode

When multiple mirror relationships exist on a single storage array and have been configured to use Asynchronous write mode and to preserve consistent write order, they are considered to be an interdependent group that is in the Write consistency mode. The data on the secondary, remote storage array cannot be considered fully synchronized until all of the remote mirrors that are in the Write consistency mode are synchronized.

If one mirror relationship in the group becomes unsynchronized, all of the mirror relationships in the group become unsynchronized. Any write activity to the remote, secondary storage arrays is prevented to protect the consistency of the remote data set.

Link Interruptions or Secondary Volume Errors

When processing write requests, the primary controller might be able to write to the primary volume, but a link interruption might prevent communication with the remote (secondary) controller.

In this case, the remote write operation cannot be completed to the secondary volume, and the primary volume and the secondary volume are no longer correctly mirrored. The primary controller transitions the mirrored pair into an Unsynchronized state and sends an I/O completion to the primary host. The primary host can continue to write to the primary volume, but remote writes do not take place.

When communication is restored between the controller owner of the primary volume and the controller owner of the secondary volume, a resynchronization takes place. This resynchronization happens automatically, or it must be started manually, depending on which write mode you chose when setting up the mirror relationship. During the resynchronization, only the blocks of data that have changed on the primary volume during the link interruption are copied to the secondary volume. After the resynchronization starts, the mirrored pair transitions from an Unsynchronized status to a Synchronization in Progress status.

The primary controller also marks the mirrored pair as unsynchronized when a volume error on the secondary side prevents the remote write from completing. For example, an offline secondary volume or a failed secondary volume can cause the remote mirror to become unsynchronized. When the volume error is corrected (the secondary volume is placed online or recovered to an Optimal status), then synchronization is required. The mirrored pair then transitions to a Synchronization in Progress status.

Resynchronization

Data replication between the primary volume and the secondary volume in a mirror relationship is managed by the controllers and is transparent to host machines and applications. When the controller owner of the primary volume receives a write request from a host, the controller first logs information about the write to a mirror repository volume. The controller then writes the data to the primary volume. The controller then initiates a write operation to copy the affected data to the secondary volume on the remote storage array.

If a link interruption or a volume error prevents communication with the secondary storage array, the controller owner of the primary volume transitions the mirrored pair into an Unsynchronized status. The controller owner then sends an I/O completion to the host sending the write request. The host can continue to issue write requests to the primary volume, but remote writes to the secondary volume do not take place.

When connectivity is restored between the controller owner of the primary volume and the controller owner of the secondary volume, the volumes must be resynchronized by copying the blocks of data that changed during the interruption to the secondary volume. Only the blocks of data that have changed on the primary volume during the link interruption are copied to the secondary volume.



ATTENTION Possible loss of data access – Any communication disruptions between the primary storage array and the secondary storage array while resynchronization is underway could result in a mix of new data and old data on the secondary volume. This condition would render the data unusable in a disaster recovery situation.

Performance Considerations

Keep these performance considerations in mind when you create mirror relationships:

- The controller owner of a primary volume performs a full synchronization in the background while processing local I/O writes to the primary volume and associated remote writes to the secondary volume. Because the full synchronization diverts controller processing resources from I/O writes, full synchronization can have a performance impact to the host application.
- To reduce the performance impact, you can set the synchronization priority level to determine how the controller owner will prioritize the full synchronization relative to other I/O activity. To set the synchronization priority level, consider these guidelines:
 - A full synchronization at the lowest synchronization priority level takes approximately eight times as long as a full synchronization at the highest synchronization priority level.
 - A full synchronization at the low synchronization priority level takes approximately six times as long as a full synchronization at the highest synchronization priority level.
 - A full synchronization at the medium synchronization priority level takes approximately three-and-a-half times as long as a full synchronization at the highest synchronization priority level.

- A full synchronization at the high synchronization priority level takes approximately twice as long as a full synchronization at the highest synchronization priority level.
- When the mirrored volume pair is in a Synchronization in Progress state, all host write data is copied to the remote system. Both controller I/O bandwidth and I/O latency can affect host write performance. Host read performance is not affected by the mirror relationship.
- The time that it takes for data to be copied from the primary volume to the secondary volume might impact overall performance. This impact is primarily caused by the delay and system resource required for copying data to the remote mirror. Some delay might also occur because of the limit to the number of simultaneous writes.

Enabling the Remote Volume Mirroring Premium Feature

The first step in creating a remote mirror is to make sure that the Remote Volume Mirroring premium feature is enabled on both storage arrays. Because Remote Volume Mirroring is a premium feature, you need a feature key file to enable the premium feature. The command for enabling the feature key file is as follows:

```
enable storageArray feature file="filename"
```

In this command, the `file` parameter is the complete file path and file name of a valid feature key file. Enclose the file path and the file name in double quotation marks (" "). Valid file names for feature key files end with a `.key` extension.

Activating the Remote Volume Mirroring Premium Feature

Activating the Remote Volume Mirroring premium feature prepares the storage arrays to create and configure mirror relationships. After you activate the premium feature, the secondary ports for each controller are reserved and dedicated to remote mirror use. In addition, a mirror repository volume is automatically created for each controller in the storage array. As part of the activation process, you can decide where the mirror repository volumes will reside, free capacity on an existing volume group or in a newly created volume group, and the RAID level for the mirror repository volumes.

The free capacity that you select for the mirror repository volume must have a total of 256 MB of capacity available. Two mirror repository volumes are created on this capacity, one for each controller. If you enter a value for the repository storage space that is too small for the mirror repository volumes, the firmware returns an error message that gives the amount of space needed for the mirror repository volumes. The command does not try to activate the Remote Volume Mirroring premium feature. You can re-enter the command using the value from the error message for the repository storage space value.

The RAID level that you choose for the mirror repository volume has these constraints:

- **RAID Level 0** – You cannot use RAID Level 0.
- **RAID Level 1** – The number of drives must be an even number. If you select an odd number of drives, the controller firmware returns an error.
- **RAID Level 5** – You must have a minimum of three drives in the volume group.
- **RAID Level 6** – You must have a minimum of five drives in the volume group.

To activate the Remote Volume Mirroring premium feature, use this command:

```
activate storageArray feature=remoteMirror
```

The `activate storageArray feature=remoteMirror` command provides three methods for defining the drives for your mirror repository volume:

- You define each drive for the mirror repository volume by its tray ID and its slot ID.
- You define a volume group in which the mirror repository volume resides. You can optionally define the capacity of the mirror repository volume.
- You define the number of drives, but not specific drives, for the mirror repository volume.

Activating the Remote Volume Mirroring Premium Feature with User-Assigned Drives

Activating the Remote Volume Mirroring premium feature by assigning the drives provides flexibility in defining your configuration by letting you choose from the available drives in your storage array. Choosing the drives for your remote mirror automatically creates a new volume group. You can specify which drives to use and the RAID level for the new volume group.

The command takes this form:

```
activate storageArray feature=remoteMirror
repositoryRAIDLevel=(1 | 3 | 5 | 6)
repositoryDrives=(trayID1,slotID1 ... trayIDn,slotIDn)
trayLossProtect=(TRUE | FALSE)
```

This example shows a command in which you assign the drives:

```
c:\...\smX\client>smcli 123.45.67.88 123.45.67.89
-c "activate storageArray feature=remoteMirror
repositoryRAIDLevel=5
repositoryDrives=(1,1 1,2 1,3 1,4 1,5);"
```

The command in this example creates a new mirror repository volume consisting of five drives that form a new volume group. The new volume group has RAID Level 5.

This example shows how to use the command in a script file:

```
activate storageArray feature=remoteMirror
repositoryRAIDLevel=5
repositoryDrives=(1,1 1,2 1,3 1,4 1,5);
```

Activating the Remote Volume Mirroring Premium Feature with Software-Assigned Drives

With this version of the `activate storageArray feature=remoteMirror` command, you choose an existing volume group in which to place the mirror repository volume. The storage management software then determines which drives to use. You can also define how much space to assign to the mirror repository volume. Because you are using an existing volume group, the RAID level for the mirror repository volume defaults to the RAID level of the volume group in which you place it. You cannot define the RAID level for the mirror repository volume.

The command takes this form:

```
activate storageArray feature=remoteMirror
repositoryVolumeGroup=volumeGroupNumber
[freeCapacityArea=freeCapacityIndexNumber]
```

This example shows a command in which the software assigns the drives:

```
c:\...\smX\client>smcli 123.45.67.88 123.45.67.89
-c "activate storageArray feature=remoteMirror
repositoryVolumeGroup=2 freeCapacityArea=2;"
```

The command in this example creates a new mirror repository volume in volume group 2 using the second free capacity area.

This example shows how to use the command in a script file:

```
activate storageArray feature=remoteMirror
repositoryVolumeGroup=2 freeCapacityArea=2;
```

Activating the Remote Volume Mirroring Premium Feature by Specifying a Number of Drives

With this version of the **activate storageArray feature=remoteMirror** command, you must specify the number of drives and the RAID level that you want for the mirror repository volume. This version of the command creates a new volume group. For this command to work, you must have drives in the storage array that are not assigned to a volume group.

```
activate storageArray feature=remoteMirror
repositoryRAIDLevel=(1 | 3 | 5 | 6)
repositoryDriveCount=numberOfDrives
[driveType=(fibre | SATA | SAS)]
[trayLossProtect=(TRUE | FALSE)]
```

This example shows a command in which you specify the number of drives:

```
c:\...\smX\client>smcli 123.45.67.88 123.45.67.89
-c "activate storageArray feature=remoteMirror
repositoryRAIDLevel=5 repositoryDriveCount=5
driveType=SAS;"
```

The command in this example creates a new mirror repository volume by using five software#selected drives for the mirror repository volume. The mirror repository volume has RAID Level 5. The type of drive for the mirror repository volume is SAS.

This example shows how to use the command in a script file:

```
activate storageArray feature=remoteMirror
repositoryRAIDLevel=5 repositoryCount=5
driveType=SAS;
```

Determining Candidates for a Remote Mirrored Pair

All of the volumes and drives on the remote storage array might not be available for use as secondary volumes. To determine which volumes on a remote storage array that you can use as candidates for secondary volumes, use the **show remoteMirror candidates** command. This command returns a list of the volumes that you can use when creating a remote mirror.

The command takes this form:

```
c:\...\smX\client>smcli 123.45.67.88 123.45.67.89
-c "show remoteMirror candidates primary=\"volumeName\"
remoteStorageArrayName=\"storageArrayName\";"
```

where *volumeName* is the name of the volume that you want to use for the primary volume, and *storageArrayName* is the remote storage array that contains possible candidates for the secondary volume. Enclose both the volume name and the storage array name in double quotation marks (" ").

Creating a Remote Mirrored Pair

When you create a new remote mirror, you must define which volumes that you want to use for the primary (local) volume and the secondary (remote) volume. You define the primary volume by the name of the volume. You define the secondary volume by name with either the name or the World Wide Identifier (WWID) of the storage array on which the secondary volume resides. The primary volume name, the secondary volume name, and the remote storage array name (or WWID) are the minimum information that you need to provide. Using this command, you can also define synchronization priority, write order, and write mode.

The command takes this form:

```
create remoteMirror primary="primaryVolumeName"
secondary="secondaryVolumeName"
(remoteStorageArrayName="storageArrayName" |
remoteStorageArrayWwn="wwID") remotePassword=password
syncPriority=(highest | high | medium | low | lowest)
writeOrder=(preserved | notPreserved)
writeMode=(synchronous | asynchronous)
```



NOTE You can use the optional parameters as needed to help define your configuration.

This example shows the **create remoteMirror** command:

```
c:\...\smX\client>smcli 123.45.67.88 123.45.67.89
-c "create remoteMirror primary=\"Jan_04_Account\"
secondary=\"Jan_04_Account_B\" remoteStorageArrayName=\"Tabor\"
remotePassword=\"jdw2ga05\" syncPriority=highest
writeMode=synchronous;"
```

The command in this example creates a remote mirror in which the primary volume is named Jan_04_Account on the local storage array. The secondary volume is named Jan_04_Account_B on the remote storage array that is named Tabor. The names used in this example are similar, but that is not a requirement for the volume names in a remote mirrored pair. In this example, the remote storage array has a password that you must enter when making any change to the storage array configuration. Creating a remote mirrored pair is a significant change to a storage array configuration. Setting the write mode to **synchronous** and the synchronization priority to **highest** means that host write requests are written to the primary volume and then immediately copied to the secondary volume. These actions help to make sure that the data on the secondary volume is as accurate a copy of the data on the primary volume as possible. The highest synchronization priority does, however, use more system resources, which can reduce system performance.

This example shows how to use the command in a script file:

```
create remoteMirror primary="Jan_04_Account"
secondary="Jan_04_Account_B" remoteStorageArrayName="Tabor"
remotePassword="jdw2ga05" syncPriority=highest
writeMode=synchronous;
```

After you have created a remote mirror, you can see the progress of data synchronization between the primary volume and the secondary volume by running the **show remoteMirror synchronizationProgress** command. This command shows the progress as a percentage of data synchronization that has completed.

Changing Remote Volume Mirroring Settings

The **set remoteMirror** command lets you change the property settings for a remote mirrored pair. Use this command to change these property settings:

- The volume role (either primary or secondary)
- The synchronization priority
- The write order
- The write mode

You can apply the changes to one or several remote mirrored pairs by using this command. Use the primary volume name to identify the remote mirrored pairs for which you are changing the properties.

This example shows how to use the **set remoteMirror** command:

```
c:\...\smX\client>smcli 123.45.67.88 123.45.67.89
-c "set remoteMirror localVolume [Jan_04_Account]
syncPriority=medium
writeOrder=notpreserved
writeMode=asynchronous;"
```

This example shows how to use the command in a script file:

```
set remoteMirror localVolume [Jan_04_Account]
syncPriority=medium
writeOrder=notpreserved
writeMode=asynchronous;
```

Suspending and Resuming a Mirror Relationship

Use the **suspend remoteMirror** command to stop data transfer between a primary volume and a secondary volume in a mirror relationship without disabling the mirror relationship. Suspending a mirror relationship lets you control when the data on the primary volume and data on the secondary volume are synchronized. Suspending a mirror relationship helps to reduce any performance impact to the host application that might occur while any changed data on the primary volume is copied to the secondary volume. Suspending a mirror relationship is particularly useful when you want to run a backup of the data on the secondary volume.

When a mirror relationship is in a suspended state, the primary volume does not make any attempt to contact the secondary volume. Any writes to the primary volume are persistently logged in the mirror repository volumes. After the mirror relationship resumes, any data that is written to the primary volume is automatically written to the secondary volume. Only the modified data blocks on the primary volume are written to the secondary volume. Full synchronization is not required.



IMPORTANT If you suspend a remote mirror that is set up in the Write consistency mode, you suspend all remote mirrored pairs within the group. You can then resume mirror operations for any of the individual remote mirrored pairs that are in the group.

This example shows the **suspend remoteMirror** command:

```
c:\...\smX\client>smcli 123.45.67.88 123.45.67.89
-c "suspend remoteMirror primary Jan_04_Account
writeConsistency=false;"
```

The `writeConsistency` parameter defines whether the volumes identified in this command are in a write-consistency group or are separate. For the volumes in a write#consistency group, set this parameter to **TRUE**. For the volumes that are not in a write-consistency group, set this parameter to **FALSE**.

This example shows how to use the command in a script file:

```
suspend remoteMirror volume Jan_04_Account
writeConsistency=false;
```

The mirror relationship remains suspended until you use the **resume remoteMirror** command to restart synchronization activities. This command restarts data transfers between a primary volume and a secondary volume in a mirror relationship after the mirror has been suspended or unsynchronized.

This example shows the **resume remoteMirror** command:

```
c:\...\smX\client>smcli 123.45.67.88 123.45.67.89
-c "resume remoteMirror volume Jan_04_Account
writeConsistency=false;"
```

The `writeConsistency` parameter in this command operates the same as in the previous command.

This example shows how to use the command in a script file:

```
resume remoteMirror volume Jan_04_Account
writeConsistency=false;
```

Removing a Mirror Relationship

Use the **remove remoteMirror** command to remove the link between a primary volume and a secondary volume. (Removing a mirror relationship is similar to deleting a mirror relationship.) Removing the link between a primary volume and a secondary volume does not affect any of the existing data on either volume. The link between the volumes is removed, but the primary volume still continues normal I/O operations. Later, you can establish the mirror relationship between the two volumes and resume normal mirror operations. You can remove the mirror relationship for one or several remote mirrored pairs with this command.

This example shows the **remove remoteMirror** command:

```
c:\...\smX\client>smcli 123.45.67.88 123.45.67.89
-c "remove remoteMirror localVolume [Jan_04_Account];"
```

When you run this command, use the name of the primary volume of the remote mirrored pair.

This example shows how to use the command in a script file:

```
remove remoteMirror localVolume [Jan_04_Account];
```

To re-establish the link between a primary volume and a secondary volume, use the **create remoteMirror** command.

Deleting a Primary Volume or a Secondary Volume

Use the `delete volume` command to remove a primary volume or a secondary volume from a storage array. Deleting a volume in a mirror relationship removes the mirror relationship and completely deletes the volume from the storage array. You cannot redefine the mirror relationship until you create a new volume or choose an alternate volume to replace the deleted volume.



ATTENTION Possible loss of data access – Deleting a primary volume or a secondary volume permanently removes the data from the storage array.

Disabling the Remote Volume Mirroring Premium Feature

You disable the Remote Volume Mirroring premium feature to prevent the new mirror relationship from being created. When you disable the Remote Volume Mirroring premium feature, the premium feature is in a Disabled/Active state. In this state, you can maintain and manage previously existing mirror relationships; however, you cannot create new relationships. To disable the Remote Volume Mirroring premium feature, use this command:

```
disable storageArray feature=remoteMirror
```

Deactivating the Remote Volume Mirroring Premium Feature

If you no longer require the Remote Volume Mirroring premium feature and you have removed all of the mirror relationships, you can deactivate the premium feature. Deactivating the premium feature reestablishes the normal use of dedicated ports on both storage arrays and deletes both mirror repository volumes. To deactivate the Remote Volume Mirroring premium feature, use this command:

```
deactivate storageArray feature=remoteMirror
```

Interaction with Other Premium Features

You can run the Remote Volume Mirroring premium feature while running these premium features:

- Storage Partitioning
- Snapshot
- Volume Copy

When you run the Remote Volume Mirroring premium feature with other premium features, you must consider the requirements of the other premium features to help make sure that you set up a stable storage array configuration.

In addition to running with the premium features, you can also run the Remote Volume Mirroring premium feature while running Dynamic Volume Expansion (DVE).

Storage Partitioning

Storage Partitioning is a premium feature that lets hosts share access to volumes in a storage array. You create a storage partition when you define any of these logical components in a storage array:

- A host
- A host group

- A volume-to-LUN mapping

The volume-to-LUN mapping lets you define which host group or host has access to a particular volume in the storage array.

When you create storage partitions, define the storage partitions after you have created the primary volume and the secondary volume in a Remote Volume Mirroring configuration. The storage partition definitions for the primary storage array and the secondary storage array are independent of each other. If these definitions are put in place while the volume is in a secondary role, the administrative effort associated with the site recovery is reduced if it becomes necessary to promote the volume to a primary role.

Snapshot Volumes

A snapshot is a point-in-time image of a volume. Typically, it is created so that an application, such as a backup application, can access the snapshot volume and read the data while the base volume stays online and is accessible to hosts.

The volume for which the point-in-time image is created is known as the base volume and must be a standard volume in the storage array. The snapshot repository volume stores information about all data that changed since the snapshot was created.

In this version of the storage management software, you can create snapshot volumes based on the primary volume or secondary volume of a remote mirror.

Volume Copy

The Volume Copy premium feature copies data from one volume (the source volume) to another volume (the target volume) within a single storage array. You can use this premium feature to perform these functions:

- Copy data from volume groups that use smaller-capacity drives to volume groups that use larger-capacity drives
- Back up data
- Restore snapshot volume data to the base volume.

You can use a primary volume in a remote mirror as a source volume or a target volume in a volume copy. You cannot use a secondary volume as a source volume or a target volume.



NOTE If you start a role reversal during a copy-in-progress, the copy fails and cannot be restarted.

Dynamic Volume Expansion

A Dynamic Volume Expansion (DVE) is a modification operation that increases the capacity of a standard volume or a snapshot repository volume. The increase in capacity is achieved by using the free capacity that is available in the volume group of the standard volume or the snapshot repository volume.

This modification operation is considered to be “dynamic” because you can continually access data on volume groups, volumes, and drives throughout the entire operation.

A DVE operation can be performed on a primary volume or a secondary volume of a mirror relationship.



NOTE Although the storage management software indicates that the volume has increased capacity, its usable capacity is the size of the smaller of the primary volume or the secondary volume.

You cannot perform a DVE operation on a mirror repository volume.

Using the Volume Copy Premium Feature

The Volume Copy premium feature lets you copy data from one volume (the source) to another volume (the target) in a single storage array. You can use this premium feature to perform these tasks:

- Back up data
- Copy data from volume groups that use smaller-capacity drives to volume groups using greater-capacity drives
- Restore snapshot volume data to the associated base volume

How Volume Copy Works

When you create a volume copy, you create a copy pair that consists of a source volume and a target volume. Both the source volume and the target volume are located on the same storage array. During a volume copy, the controllers manage copying the data from the source volume to the target volume. The volume copy is transparent to the host machines and applications, except that users cannot write to the source volume during a volume copy.

While a volume copy is In Progress, the same controller must own both the source volume and the target volume. If one controller does not own both the source volume and the target volume before creating the volume copy, ownership of the target volume is automatically transferred to the controller that owns the source volume. When the volume copy is finished or stopped, ownership of the target volume is restored to its preferred controller. If ownership of the source volume changes while a volume copy is running, ownership of the target volume also changes.

Source Volume

The source volume is the volume that accepts host I/O and stores data. When you start a volume copy, data from the source volume is copied in its entirety to the target volume. While a volume copy has a status of In Progress, Pending, or Failed, the source volume is available only for read activity.

After the volume copy completes, the source volume becomes available to host applications for write requests. The target volume automatically becomes read only to hosts, and write requests to the target volume are rejected.

The following are valid source volumes:

- A standard volume
- A snapshot volume
- The base volume of a snapshot volume
- A primary volume that is participating in a remote-mirror pair

The following are not valid source volumes:

- A secondary volume that is participating in a remote-mirror pair
- A snapshot repository volume
- A mirror repository volume
- A failed volume
- A missing volume
- A volume currently in a modification operation

- A volume that is holding a Small Computer System Interface-2 (SCSI-2) reservation or a persistent reservation
- A volume that is a source volume or a target volume in another volume copy that has a status of In Progress, Pending, or Failed

Target Volume

A target volume contains a copy of the data from the source volume. When a volume copy is started, data from the source volume is copied in its entirety to the target volume.



ATTENTION Possible loss of data access – A volume copy overwrites data on the target volume. Before you start a new operation, make sure that you no longer need the old data, or you have backed up the old data on the target volume.

While the volume copy has a status of In Progress, Pending, or Failed, the controllers reject read and write requests to the target volume. After the volume copy operation is finished, the target volume automatically becomes read only to the hosts, and write requests to the target volume are rejected. You can change the Read-Only attribute after the volume copy has completed or has been stopped. (For more information about the Read-Only attribute, see [“Viewing Volume Copy Properties.”](#))

The following volumes are valid target volumes:

- A standard volume
- The base volume of a disabled snapshot volume or failed snapshot volume
- A primary volume that is participating in a remote-mirror pair

The following volumes are not valid target volumes:

- The base volume of an active snapshot volume
- A snapshot volume
- A mirror repository volume
- A snapshot repository volume
- A secondary volume in a remote-mirror pair
- A failed volume
- A missing volume
- A volume with a status of Degraded
- A volume that is currently in a modification operation
- A volume that is holding a SCSI-2 reservation or a persistent reservation
- A volume that is a source volume or a target volume in another volume copy that has a status of In Progress, Pending, or Failed

Volume Copy and Persistent Reservations

You cannot use volumes that hold persistent reservations for either a source volume or a target volume. Persistent reservations are configured and managed through the server cluster software and prevent other hosts from accessing the reserved volume. Unlike other types of reservations, a persistent reservation reserves host access to the volume across multiple HBA host ports, which provides various levels of access control.

To determine which volumes have reservations, run the `show (volume) reservations` command. To remove a reservation, run the `clear (volume) reservations` command.

Storage Array Performance

During a volume copy operation, the resources of the storage array might be diverted from processing I/O activity to completing a volume copy, which might affect the overall performance of the storage array.

These factors contribute to the performance of the storage array:

- The I/O activity
- The volume RAID level
- The volume configuration (number of drives in the volume groups and cache parameters)
- The volume type (snapshot volumes might take more time to copy than standard volumes)

When you create a new volume copy, you define the copy priority to determine how much controller processing time is allocated for a volume copy compared with I/O activity.

Copy priority has five relative settings ranging from highest to lowest. The highest priority rate supports the volume copy, but I/O activity might be affected. The lowest priority rate supports I/O activity, but the volume copy takes longer. You define the copy priority when you create the volume copy pair. You can redefine the copy priority later by using the `set volumeCopy` command. You can also redefine the volume copy priority when you recopy a volume.

Restrictions

These restrictions apply to the source volume, the target volume, and the storage array:

- While a volume copy operation has a status of In Progress, Pending, or Failed, the source volume is available for read activity only. After the volume copy finishes, read activity from and write activity to the source volume is permitted.
- A volume can be selected as a target volume for only one volume copy at a time.
- The maximum allowable number of volume copies per storage array depends upon the storage array configuration.
- A volume that is reserved by the host cannot be selected as a source volume or as a target volume.
- A volume with a status of Failed cannot be used as a source volume or as a target volume.
- A volume with a status of Degraded cannot be used as a target volume.
- You cannot select a volume that is participating in a modification operation as a source volume or as a target volume. Modification operations include Dynamic Capacity Expansion (DCE), Dynamic RAID Level Migration (DRM), Dynamic Segment Sizing (DSS), Dynamic Volume Expansion (DVE), and defragmenting a volume group.

Volume Copy Commands

The following table lists the Volume Copy commands and briefly describes what the commands do.

Volume Copy Commands

| Command | Description |
|---|---|
| <code>create volumeCopy</code> | Creates a volume copy and starts the volume copy operation. |
| <code>disable storageArray featurevolumeCopy</code> | Turns off the current volume copy operation. |
| <code>enable storageArray feature</code> | Activates the Volume Copy premium feature. |
| <code>recopy volumeCopy</code> | Re-initiates a volume copy operation using an existing volume copy pair. |
| <code>remove volumeCopy</code> | Removes a volume copy pair. |
| <code>set volumeCopy</code> | Defines the properties for a volume copy pair. |
| <code>show volumeCopy</code> | Returns information about volume copy operations. You can retrieve information about a specific volume copy pair, or all of the volume copy pairs in the storage array. |
| <code>show volumeCopy sourceCandidates</code> | Returns information about the candidate volumes that you can use as the source for a volume copy operation. |
| <code>show volumeCopy targetCandidates</code> | Returns information about the candidate volumes that you can use as the target for a volume copy operation. |
| <code>stop volumeCopy</code> | Stops a volume copy operation. |

Creating a Volume Copy

Before you create a volume copy, make sure that a suitable target volume exists on the storage array, or create a new target volume specifically for the volume copy. The target volume that you use must have a capacity equal to or greater than the source volume.

You can have a maximum of eight volume copies with a status of In Progress at one time. Any volume copy greater than eight has a status of Pending until one of the volume copies with a status of In Progress has completed the volume copy process.

To create a volume copy, perform these general steps:

1. Enable the Volume Copy premium feature.
2. Determine the candidates for a volume copy.
3. Create the target volume and the source volume for the volume copy.

Enabling the Volume Copy Premium Feature

The first step in creating a volume copy is to make sure that the feature is enabled on the storage array. Because Volume Copy is a premium feature, you need a Feature Key file to enable the feature. This command enables the Feature Key file:

```
enable storageArray feature file="filename"
```

where the `file` parameter is the complete file path and file name of a valid Feature Key file. Enclose the file path and file name in double quotation marks (" "). Valid file names for Feature Key files usually end with a `.key` extension.

Determining Volume Copy Candidates

All volumes and drives might not be available for use in volume copy operations. To determine which candidate volumes on the storage array that you can use as a source volume, use the commands in the following table.

| Action | Use This CLI Command |
|---|---|
| Determine which candidate volumes on the storage array you can use as a source volume | <code>show volumeCopy sourceCandidates</code> |
| Determine which candidate volumes on the storage array you can use as a target volume | <code>show volumeCopy targetCandidates</code> |

The `show volumeCopy sourceCandidates` command and the `show volumeCopy targetCandidates` command return a list of the drive tray, slot, and capacity information for the source volume candidates and the target volume candidates.

You can use the `show volumeCopy sourceCandidates` command and the `show volumeCopy targetCandidates` command only after you have enabled the Volume Copy premium feature.

Creating a Volume Copy

 **ATTENTION Possible loss of data access** – A volume copy overwrites data on the target volume. Make sure that you no longer need the data or have backed up the data on the target volume before you start a volume copy operation.

When you create a volume copy, you must define which volumes that you want to use for the source volume and the target volume. You define the source volume and the target volume by the name of each volume. You can also define the copy priority and choose whether you want the target volume to be read only after the data is copied from the source volume.

The command has this form:

```
create volumeCopy
source="sourceName" target="targetName"
[copyPriority=(highest | high | medium | low | lowest)
targetReadOnlyEnabled=(TRUE | FALSE)]
```

Before you run the `create volumeCopy` command, perform these actions:

- Stop all I/O activity to the source volume and the target volume.
- Dismount any file systems on the source volume and the target volume, if applicable.

This example shows the **create volumeCopy** command:

```
c:\...\smX\client>smcli 123.45.67.88 123.45.67.89
-c "create volumeCopy source=\"Jaba_Hut\" target=\"Obi_1\"
copyPriority=medium targetReadOnlyEnabled=TRUE;"
```

The command in this example copies the data from the source volume named `Jaba_Hut` to the target volume named `Obi_1`. Setting the copy priority to **medium** provides a compromise between how quickly the data is copied from the source volume to the target volume and the amount of processing resources that are required for data transfers to other volumes in the storage array. Setting the `targetReadOnlyEnabled` parameter to **TRUE** means that write requests cannot be made to the target volume, making sure that the data on the target volume stays unaltered.

This example shows how to use the command in a script file:

```
create volumeCopy source="Jaba_Hut" target="Obi_1"
copyPriority=medium targetReadOnlyEnabled=TRUE;
```

After the volume copy operation is completed, the target volume automatically becomes read only to hosts. Any write requests to the target volume are rejected, unless you disable the Read-Only attribute by using the **set volumeCopy** command.

To view the progress of a volume copy, use the **show volume actionProgress** command. This command returns information about the volume action, the percentage completed, and the time remaining until the volume copy is complete.

Viewing Volume Copy Properties

Use the **show volumeCopy** command to view information about one or more selected source volumes or target volumes. This command returns these values:

- The role
- The copy status
- The start time stamp
- The completion time stamp
- The copy priority
- The Read-Only attribute setting for the target volume
- The source volume World Wide Identifier (WWID) or the target volume WWID

If a volume is participating in more than one volume copy (it can be a source volume for one volume copy operation and a target volume for another volume copy operation), the details are repeated for each associated copy pair.

The command has this form:

```
show volumeCopy (allVolumes | source [sourceName] |
target [targetName])
```

This example shows the **show volumeCopy** command:

```
c:\...\smX\client>smcli 123.45.67.88 123.45.67.89
-c "show volumeCopy source [\"JabaHut\"];"
```

The command in this example is requesting information about the source volume Jaba_Hut. If you wanted information about all of the volumes, you would use the `allVolumes` parameter. You can also request information about a specific target volume.

This example shows how to use the command in a script file:

```
show volumeCopy source [\"Jaba_Hut\"];
```

Changing Volume Copy Settings

The `set volumeCopy` command lets you change these property settings for a volume copy pair:

- The copy priority
- The target volume read/write permission

Copy priority has five relative settings ranging from highest to lowest. The highest priority supports the volume copy, but I/O activity might be affected. The lowest priority supports I/O activity, but the volume copy takes longer. You can change the copy priority at these times:

- Before the volume copy operation starts
- While the volume copy operation has a status of In Progress
- After the volume copy operation has completed when re-creating a volume copy operation by using the `recopy volumeCopy` command

When you create a volume copy pair and after the original volume copy has completed, the target volume is automatically defined as read-only to the hosts. The read-only status of the target volume helps to make sure that the copied data on the target volume is not corrupted by additional writes to the target volume after the volume copy is created. You want to maintain the read-only status when you are performing these tasks:

- Using the target volume for backup purposes
- Copying data from one volume group to a larger volume group for greater accessibility
- Planning to use the data on the target volume to copy back to the base volume in case of a disabled snapshot volume or failed snapshot volume

At other times, you might want to write additional data to the target volume. You can use the `set volumeCopy` command to reset the read/write permission for the target volume.



NOTE If you have set the volume copy parameters to enable host writes to the target volume, the read request and the write request to the target volume are rejected while the volume copy operation has a status of In Progress, Pending, or Failed.

The command has this form:

```
set volumeCopy target [targetName] [source [sourceName]]
copyPriority=(highest | high | medium | low | lowest)
targetReadOnlyEnabled=(TRUE | FALSE)
```



NOTE You can use the parameters as needed to help define your configuration.

This example shows the **set volumeCopy** command:

```
c:\...\smX\client>smcli 123.45.67.88 123.45.67.89
-c "set volumeCopy target ["Obi_1\"]
copyPriority=highest
targetReadOnlyEnabled=FALSE;"
```

This example shows how to use the command in a script file:

```
set volumeCopy target ["Obi_1"] copyPriority=highest
targetReadOnlyEnabled=FALSE;
```

Recopying a Volume

Use the **recopy volumeCopy** command to create a new volume copy for a previously defined copy pair that has a status of Stopped, Failed, or Completed. You can use the **recopy volumeCopy** command to create backups of the target volume. Then, you can copy the backup to tape for off-site storage. When you use the **recopy volumeCopy** command to make a backup, you cannot write to the source volume while the recopy operation is running. The recopy operation might take a long time.

When you run the **recopy volumeCopy** command, the data on the source volume is copied in its entirety to the target volume.



ATTENTION Possible loss of data access – The **recopy volumeCopy** command overwrites existing data on the target volume and makes the target volume read-only to hosts. The **recopy volumeCopy** command fails all of the snapshot volumes that are associated with the target volume, if any exist.

You can also reset the copy priority by using the **recopy volumeCopy** command if you want to change the copy priority for the recopy operation. The higher priorities allocate storage array resources to the volume copy at the expense of storage array performance.

The command has this form:

```
recopy volumeCopy target [targetName] [source [sourceName]]
copyPriority=(highest | high | medium | low | lowest)
targetReadOnlyEnabled=(TRUE | FALSE)]
```



NOTE You can use the optional parameters as needed to help define your configuration.

This example shows the **show volumeCopy** command:

```
c:\...\smX\client>smcli 123.45.67.88 123.45.67.89
-c "recopy volumeCopy target ["Obi_1\"] copyPriority=highest;"
```

The command in this example copies data from the source volume that is associated with the target volume Obi_1 to the target volume again. The copy priority is set to the highest value to complete the volume copy as quickly as possible. The underlying consideration for using this command is that you have already created the volume copy pair, which has already created one volume copy. By using this command, you are copying the data from the source volume to the target volume with the assumption that the data on the source volume has changed since the previous copy was made.

This example shows you how to use the command in a script file:

```
recopy volumeCopy target ["Obi_1"] copyPriority=highest;
```

Stopping a Volume Copy

The **stop volumeCopy** command lets you stop a volume copy that has a status of In Progress, Pending, or Failed. After you have stopped a volume copy, you can use the **recopy volumeCopy** command to create a new volume copy by using the original volume copy pair. After you stop a volume copy operation, all of the mapped hosts will have write access to the source volume.

The command has this form:

```
stop volumeCopy target [targetName] [source [sourceName]]
```

This example shows the **show volumeCopy** command:

```
c:\...\smX\client>smcli 123.45.67.88 123.45.67.89  
-c "stop volumeCopy target [\"Obi_1\"];"
```

This example shows how to use the command in a script file:

```
stop volumeCopy target ["Obi_1"];
```

Removing Copy Pairs

The **remove volumeCopy** command lets you remove a volume copy pair from the storage array configuration. All of the volume copy-related information for the source volume and the target volume is removed from the storage array configuration. The data on the source volume or the target volume is not deleted. Removing a volume copy from the storage array configuration also removes the Read-Only attribute for the target volume.



IMPORTANT If the volume copy has a status of In Progress, you must stop the volume copy before you can remove the volume copy pair from the storage array configuration.

The command has this form:

```
remove volumeCopy target [targetName] [source [sourceName]]
```

This example shows the **remove volumeCopy** command:

```
c:\...\smX\client>smcli 123.45.67.88 123.45.67.89  
-c "remove volumeCopy target [\"Obi_1\"];"
```

This example shows how to use the command in a script file:

```
remove volumeCopy target ["Obi_1"];
```

Interaction with Other Premium Features

You can run the Volume Copy premium feature while running the following premium features:

- Storage Partitioning
- Snapshot

- Remote Volume Mirroring

When you are running the Volume Copy premium feature with other premium features, you must consider the requirements of other premium features to help make sure that you set up a stable storage array configuration.

In addition to the premium features, you also can run the Volume Copy premium feature while running Dynamic Volume Expansion (DVE).

Storage Partitioning

Storage Partitioning is a premium feature that lets hosts share access to volumes in a storage array. You create a storage partition when you define any of these logical components in a storage array:

- A host
- A host group
- A volume-to-LUN mapping

The volume-to-LUN mapping lets you define which host group or host has access to a particular volume in the storage array.

After you create a volume copy, the target volume automatically becomes read only to hosts to make sure that the data is preserved. Hosts that have been mapped to a target volume do not have write access to the volume, and any attempt to write to the read-only target volume results in a host I/O error.

If you want hosts to have write access to the data on the target volume, use the `set volumeCopy` command to disable the Read-Only attribute for the target volume.

Snapshot Volumes

A snapshot is a point-in-time image of a volume. It is usually created so that an application, such as a backup application, can access the snapshot volume and read the data while the base volume stays online and is accessible to hosts.

The volume for which the point-in-time image is created is known as the base volume and must be a standard volume in the storage array. The snapshot repository volume stores information about all of the data that changed since the snapshot was created.

You can select snapshot volumes as the source volumes for a volume copy. This selection is a good use of this premium feature, because it performs complete backups without significant impact to the storage array I/O. Some I/O processing resources are lost to the copy operation.



IMPORTANT If you choose the base volume of a snapshot volume as your target volume, you must disable all of the snapshot volumes that are associated with the base volume before you can select it as a target volume.

When you create a snapshot volume, a snapshot repository volume is automatically created. The snapshot repository volume stores information about the data that has changed since the snapshot volume was created. You cannot select a snapshot repository volume as a source volume or a target volume in a volume copy.

You can use the Snapshot Volume premium feature with the Volume Copy premium feature to back up data on the same storage array and to restore the data on the snapshot volume back to its original base volume.

Remote Volume Mirroring

The Remote Volume Mirroring premium feature provides for online, real-time replication of data between storage arrays over a remote distance. In the event of a disaster or a catastrophic failure of one storage array, you can promote a secondary storage array to take over responsibility for data storage.

When you create a remote mirror, a remote-mirror pair is created, which consists of a primary volume at the primary storage array and a secondary volume at a remote storage array.

The primary volume is the volume that accepts host I/O and stores data. When the mirror relationship is initially created, data from the primary volume is copied in its entirety to the secondary volume. This process is known as a full synchronization and is directed by the controller owner of the primary volume. During a full synchronization, the primary volume remains fully accessible for all normal I/O activity.

The controller owner of the primary volume starts remote writes to the secondary volume to keep the data on the two volumes synchronized. Whenever the data on the primary volume and the secondary volume becomes unsynchronized, the controller owner of the primary volume starts a resynchronization, where only the data that changed during the interruption is copied.

The secondary volume maintains a mirror of the data on its associated primary volume. The controller owner of the secondary volume receives remote writes from the controller owner of the primary volume but does not accept host write requests.

The secondary volume stays available to host applications as read-only while mirroring is underway. In the event of a disaster or a catastrophic failure at the primary site, you can perform a role reversal to promote the secondary volume to a primary role. Hosts are then able to access the newly promoted volume, and business operations can continue.

You can select a primary volume that is participating in a remote-mirror pair to be used as the source volume or a target volume for a volume copy. A secondary volume that is participating in a remote-mirror pair cannot be selected as a source volume or a target volume.

Role Reversals

A role reversal is the act of promoting the secondary volume to be the primary volume of the remote-mirror pair, and demoting the primary volume to be the secondary volume.

In the event of a disaster at the storage array that contains the primary volume, you can fail over to the secondary site by performing a role reversal to promote the secondary volume to the primary volume role. This action lets hosts continue to access data, and business operations can continue.

Trying a role reversal in which the original primary volume is the source volume for an active volume copy (the status is In Progress or Pending) causes the volume copy to fail. The failure occurs when the original primary volume becomes the new secondary volume. You cannot restart the volume copy until you return the roles of the volumes back to their original state; that is, the volume that was originally the primary volume is set once again to be the primary volume.

If the primary storage array is recovered but is unreachable due to a link failure, a forced promotion of the secondary volume will result in both the primary volume and the secondary volume viewing themselves in the primary volume role (dual-primary condition). If this condition occurs, the volume copy in which the primary volume is participating is unaffected by the role change.

You can perform a role reversal by using the `set remoteMirror` command.

- To change a secondary volume to a primary volume, use this command, which promotes the selected secondary volume to become the primary volume of the remote-mirror pair. Use this command after a catastrophic failure has occurred.

```
set remoteMirror role=primary
```

- To change a primary volume to a secondary volume, use this command, which demotes the selected primary volume to become the secondary volume. Use this command after a catastrophic failure has occurred.

```
set remoteMirror role=secondary
```

Maintaining a Storage Array

Maintenance covers a broad spectrum of activity with the goal of keeping a storage array operational and available to all hosts. This chapter provides descriptions of commands you can use to perform storage array maintenance. The commands are organized into four sections:

- Routine maintenance
- Performance tuning
- Troubleshooting and diagnostics
- Recovery operations

The organization is not a rigid approach, and you can use the commands as appropriate for your storage array. The commands listed in this chapter do not cover the entire array of commands you can use for maintenance. Other commands, particularly the `set` commands, can provide diagnostic or maintenance capabilities.

Routine Maintenance

Routine maintenance involves those tasks that you might perform periodically to make sure that the storage array is running as well as possible or to detect conditions before they become problems.

Running a Media Scan

Media scan provides a way of detecting drive media errors before they are found during a normal read from or write to the drives. Any media scan errors that are detected are reported to the Event Log. The Event Log provides an early indication of an impending drive failure and reduces the possibility of encountering a media error during host operations. A media scan is performed as a background operation and scans all data and redundancy information in defined user volumes.

A media scan runs on all of the volumes in the storage array that have these conditions:

- Has Optimal status
- Has no modification operations in progress
- Has media scan enabled

Errors that are detected during a scan of a user volume are reported to the Major Event Log (MEL) and handled as follows:

- **Unrecovered media error** – The drive could not read the requested data on its first try or on any subsequent retries. The result of this action is that for volumes with redundancy protection, the data is reconstructed, rewritten to the drive, and verified, and the error is reported to the Event Log. For volumes without redundancy protection, the error is not corrected, but it is reported to the Event Log.
- **Recovered media error** – The drive could not read the requested data on its first attempt. The result of this action is that the data is rewritten to the drive and verified. The error is reported to the Event Log.
- **Redundancy mismatches** – Redundancy errors are found, and a media error is forced on the block stripe so that it is found when the drive is scanned again. If redundancy is repaired, this forced media error is removed. The result of this action is that the first 10 redundancy mismatches found on a volume are reported to the Event Log.
- **Unfixable error** – The data could not be read, and parity information or redundancy information could not be used to regenerate it. For example, redundancy information cannot be used to reconstruct data on a degraded volume. The result of this action is that the error is reported to the Event Log.

The script command set provides two commands to define media scan properties:

- **set volume**
- **set storageArray**

The **set volume** command enables a media scan for the volume. The command has this form:

```
set (allVolumes | volume [volumeName] |
volumes [volumeName1 ... volumeNameN] |
volume <wwID>)
mediaScanEnabled=(TRUE | FALSE)
```

The **set storageArray** command defines how frequently a media scan is run on a storage array. The command has this form:

```
set storageArray mediaScanRate=(disabled | 1-30)
```

The `mediaScanRate` values define the number of days over which the media scan runs. Valid values are **disabled**, which turns off the media scan; or 1 day to 30 days, where 1 day is the fastest scan rate, and 30 days is the slowest. A value other than what is shown will not allow the media scan to function.

Running a Redundancy Check

Redundancy checks are performed when media scans are run. (For a description about how to set up and run media scans, see [“Running a Media Scan.”](#)) During a redundancy check, all of the data blocks in a volume are scanned, and, depending on the RAID level, deteriorated data is corrected. Correction is performed as follows:

- For RAID Level 3, RAID Level 5, or RAID Level 6 volumes, redundancy is checked and repaired.
- For RAID Level 1 volumes, the data is compared between the mirrored drives and data inconsistencies are repaired.
- RAID Level 0 volumes have no redundancy.

Before you can run a redundancy check, you must enable redundancy checking by using the **set volume** command. The command has this form:

```
set (allVolumes | volume [volumeName] |
volumes [volumeName1 ... volumeNameN] |
volume <wwID>)
redundancyCheckEnabled=(TRUE | FALSE)
```

Resetting a Controller



IMPORTANT When you reset a controller, the controller is no longer available for I/O operations until the reset is complete. If a host is using volumes that are owned by the controller being reset, the I/O that is directed to the controller is rejected. Before resetting the controller, either make sure that the volumes that are owned by the controller are not in use, or make sure that a multi-path driver is installed on all of the hosts that are using these volumes.

Resetting a controller is the same as rebooting the controller processors. To reset a controller, use this command:

```
reset controller [(a | b)]
```

Enabling a Controller Data Transfer

At times, a controller might become quiescent while running diagnostics. If this condition occurs, the controller might become unresponsive. To revive a controller that has become quiescent while running diagnostics, use this command:

```
enable controller [(a | b)] dataTransfer
```

Resetting the Battery Age

After you have replaced the batteries in the storage array, you must reset the age of the battery. You can reset either the batteries for an entire storage array or a battery in a specific controller. To reset the age of the batteries to zero days, use this command:

```
reset storageArray batteryInstallDate [controller=(a | b)]
```



NOTE This command is supported only by controller trays and controller-drive trays released before the CE6998 controller tray. The batteries in controller trays and controller-drive trays released after the CE6998 controller tray do not require that you reset the battery age after you have replaced the batteries.

Removing Persistent Reservations

Persistent reservations preserve volume registrations, and they prevent hosts, other than the host defined for the volume, from accessing the volume. You must remove persistent reservations before you make these changes to your configuration:

- Change or delete LUN mappings on a volume holding a reservation
- Delete volume groups or volumes that have any reservations

To determine which volumes have reservations, use this command:

```
show (allVolumes | volume [volumeName] |  
volumes [volumeName1 ... volumeNameN]) reservations
```

To clear persistent volume reservations, use this command:

```
clear (allVolumes | volume [volumeName] |  
volumes [volumeName1 ... volumeNameN]) reservations
```

Synchronizing the Controller Clocks

To synchronize the clocks on both controllers in a storage array with the host clock, use this command:

```
set storageArray time
```

Locating Drives

At times, you might need to locate a specific drive. In very large storage array configurations, this task can sometimes be awkward. If you need to locate a specific drive, you can do so by turning on the indicator light on the front of the drive. To locate a drive, use this command:

```
start drive [trayID,slotID] locate
```

To turn off the indicator light after locating the drive, use this command:

```
stop drive locate
```

Relocating a Volume Group

Volume group relocation describes the action of moving drives within the same storage array. This is a supported capability; however, any relocation of storage array components must be completed under the guidance of your Customer and Technical Support representative.

This section describes the commands that you use to remove a set of drives and then reinstall them into a different storage array.

Hot and Cold Volume Group Relocation

There are two methods you can use to move volume groups: hot volume group relocation and cold volume group relocation.

- Hot volume group relocation lets you add or move storage without reconfiguring the storage array and, in some cases, without rebooting. During hot volume group relocation, the storage array power is not turned off.
- Cold volume group relocation requires that the power to the source storage array and the destination storage array be turned off before moving the volume groups from one storage array to another. Then the power to the storage arrays can be turned on.

To make sure that any volume group being moved to a different destination storage array is correctly recognized and managed by the new storage array, use hot volume group relocation whenever possible.



ATTENTION Possible loss of data access – You must move a single volume group at a time, and it must go into a storage array with the same level of controller firmware.

Basic Process Steps

Relocating a volume group includes these procedures:

1. Verifying the status of the storage array
2. Locating the drives in the volume group
3. Placing the volume group offline
4. Removing drives from the storage array
5. Replacing a volume group into the new storage array

To perform these steps, you must be familiar with the following CLI commands. The command syntax is provided to assist in your use of these new commands.

Volume Group Relocation Commands

Use the following command to place a specific storage array into an exported state so that its drives can be removed.

```
start volumeGroup [volumeGroupName] export
```

At this point you are allowed to remove the drives that comprise the volume group, and physically reinstall them into a different storage array.

Use the following command to logically move a specific storage array from an exported state to the complete state.

```
start volumeGroup [volumeGroupName] import
```

Your relocated volume group is now available for use.

For additional information, refer to these commands in the *Command Line Interface and Script Commands for Version 10.75*:

- `show volumeGroup exportDependencies`
- `show volumeGroup importDependencies`
- `show volumeGroup export`
- `show volumeGroup import`

Performance Tuning

Over time, as a storage array exchanges data between the hosts and the drives, its performance can degrade. You can monitor the performance of a storage array and make adjustments to the operational settings on the storage array to help improve performance.

Monitoring the Performance

You can monitor the performance of a storage array by using the `save storageArray performanceStats` command. This command saves performance information to a file that you can review to help determine how well the storage array is running. The following table lists the performance information that is saved to the file.

Information About Storage Array Performance

| Type of Information | Description |
|----------------------|---|
| Devices | These devices are included in the file: <ul style="list-style-type: none"> ▪ Controllers – The controller in slot A or slot B and a list of the volumes that are owned by the controller ▪ Volumes – A list of the volume names ▪ Storage array totals – A list of the totals for both controllers in an active/active controller pair, regardless if one, both, or neither are selected for monitoring |
| Total I/Os | The number of total I/Os performed since the storage array was started |
| Read Percentage | The percentage of total I/Os that are read operations (calculate the write percentage by subtracting the read percentage from 100 percent) |
| Cache Hit Percentage | The percentage of reads that are fulfilled by data from the cache rather than requiring an actual read from a drive |

| Type of Information | Description |
|-------------------------------|---|
| Current KB per second | The current transfer rate in kilobytes per second (current means that the number of kilobytes per second since the last time that the polling interval elapsed, causing an update to occur) |
| Maximum KB per second | The highest data transfer value that is achieved in the current kilobyte-per-second statistic block |
| Current I/O per second (IOPS) | The current number of I/Os per second (current means the number of I/Os per second since the last time that the polling interval elapsed, causing an update to occur) |
| Maximum I/O per second | The highest number of I/Os achieved in the current I/O-per-second statistic block |

The command takes this form:

```
save storageArray performanceStats file="filename"
```

where *filename* is the name of the file in which you want to save the performance statistics. You can use any file name that your operating system can support. The default file type is `.csv`. The performance information is saved as a comma-delimited file.

Before you use the `save storageArray performanceStats` command, run these commands to specify how often statistics are collected.

- `set session performanceMonitorInterval`
- `set session performanceMonitorIterations`

Changing the RAID Levels

When you create a volume group, you can define the RAID level for the volumes in that volume group. You can change the RAID level later to improve performance or provide more secure protection for your data.

 **NOTE** RAID Level 6 is a premium feature for the CDE3992 controller-drive tray, CDE3994 controller-drive tray, and the CE4900 controller-drive tray. You must enable RAID Level 6 with the feature key file before you can use the Dynamic RAID-level Migration feature.

To change the RAID level, use this command:

```
set volumeGroup [volumeGroupName]
raidLevel=(0 | 1 | 3 | 5 | 6)
```

In this command, *volumeGroupName* is the number of the volume group for which you want to change the RAID level.

Changing the Segment Size

When you create a new volume, you can define the segment size for that volume. In addition, you can change the segment size later to optimize performance. In a multiuser database or file system storage environment, set your segment size to minimize the number of drives that are needed to satisfy an I/O request. Use larger values for the segment size. Using a single drive for a single request leaves other drives available to

simultaneously service other requests. If the volume is in a single-user large I/O environment, performance is maximized when a single I/O request is serviced with a single data stripe; use smaller values for the segment size. To change the segment size, use this command:

```
set volume ([volumeName] | <wwID>) segmentSize=segmentSizeValue
```

where *segmentSizeValue* is the new segment size that you want to set. Valid segment size values are 8, 16, 32, 64, 128, 256, and 512. You can identify the volume by name or by WWID. (For usage information, refer to the **set volume** command in the *Command Line Interface and Script Commands for Version 10.75*.)

Changing the Cache Parameters

The script command **set** provides two commands that you can use to change cache parameter settings:

- **set storageArray**
- **set volume**

The **set storageArray** command lets you change settings for these items:

- The cache block size
- The cache flush start percentage
- The cache flush stop percentage

The **set volume** command lets you change settings for these items:

- The cache flush modifier
- The cache without batteries enabled or disabled
- The mirror cache enabled or disabled
- The read cache enabled or disabled
- The write cache enabled or disabled
- The read ahead multiplier
- The redundancy check enabled or disabled

Defragmenting a Volume Group

When you defragment a volume group, you consolidate the free capacity in the volume group into one contiguous area. Defragmentation does not change the way in which the data is stored on the volumes. As an example, consider a volume group with five volumes. If you delete volume 1 and volume 3, your volume group is configured as follows:

```
space, volume 2, space, volume 4, volume 5, original unused space
```

When you defragment this volume group, the space (free capacity) is consolidated into one contiguous location after the volumes. After being defragmented, the volume group appears as follows:

```
volume 2, volume 4, volume 5, consolidated unused space
```

To defragment a volume group, use this command:

```
start volumeGroup [volumeGroupNumber] defragment
```

where *volumeGroupNumber* is the identifier for the volume group.

Troubleshooting and Diagnostics

If a storage array exhibits abnormal operation or failures, you can use the commands that are described in this section to help determine the cause of the problem.

Detailed Error Reporting

Data collected from an error encountered by the CLI is written to a file. Detailed error reporting under the CLI works as follows:

- If the CLI must abnormally end running CLI commands and script commands, error data is collected and saved before the CLI finishes.
- The CLI saves the error data by writing the data to a standard file name.
- The CLI automatically saves the data to a file. Special command line options are not required to save the error data.
- You are not required to perform any action to save the error data to a file.
- The CLI does not have any provision to avoid over-writing an existing version of the file that contains error data.

For error processing, errors appear as two types:

- Terminal errors or syntax errors that you might enter
- Exceptions that occur as a result of an operational error

When the CLI encounters either type of error, the CLI writes information that describes the error directly to the command line and sets a return code. Depending on the return code, the CLI also might write additional information about which terminal caused the error. The CLI also writes information about what it was expecting in the command syntax to help you identify any syntax errors that you might have entered.

When an exception occurs while a command is running, the CLI captures the error. At the end of processing the command (after the command processing information has been written to the command line), the CLI automatically saves the error information to a file.

The name of the file to which error information is saved is `excp rpt . txt`. The CLI tries to place the `excp rpt . txt` file in the directory that is specified by the system property `devmgr . datadir`. If for any reason the CLI cannot place the file in the directory specified by `devmgr . datadir`, the CLI saves the `excp rpt . txt` file in the same directory from which the CLI is running. You cannot change the file name or the location. The `excp rpt . txt` file is overwritten every time that an exception occurs. If you want to save the information in the `excp rpt . txt` file, you must copy the information to a new file or a new directory.

Collecting All Support Data

To gather the most comprehensive information about a storage array, run the `save storageArray supportData` command. This command collects data for remote troubleshooting and analysis of problems with the storage management software. All of the files gathered are compressed into a single archive in a zipped file format. The following table lists the type of support data that is collected.

Support Data for the Storage Array

| Type of Data | Description and File Name |
|----------------------------|---|
| Storage array support data | A collection of all of the current support files for a storage array. |

| Type of Data | Description and File Name |
|--|--|
| | <p>storageArraySupportData.zip This file is not automatically generated. Create this file using the save storageArray supportData command.</p> |
| Storage array profile | <p>A list of all components and properties of a storage array. storageArrayProfile.txt</p> |
| Major Event Log | <p>A detailed list of errors that occur on the storage array. The list is stored in reserved areas on the drives in the storage array. The list records configuration events and failures with storage array components. majorEventLog.txt</p> |
| NVSRAM | <p>A controller file that specifies the default settings for the controllers. NVSRAMdata.txt</p> |
| Object bundle | <p>A detailed description of the status of the storage array and its components, which was valid at the time that the file was generated. The object bundle file is a binary file and does not contain human-readable information. objectBundle</p> |
| Performance statistics | <p>A detailed description of how a storage array is performing. Collected data includes the I/O activity of specific controllers or volumes, the transfer rate of the controller, the current I/Os per second, and the maximum I/Os per second. performanceStatistics.csv</p> |
| Persistent reservations and persistent registrations | <p>A detailed list of volumes on the storage array and persistent reservations and persistent registrations. persistentRegistrations.txt</p> |
| Read link status | <p>A detailed list of errors that have been detected in the traffic flow between the devices on the Fibre Channel loop. A file of historical read link status data might also be included in the archive. readLinkStatus.csv</p> |
| SAS physical layer (SAS PHY) | <p>A detailed list of errors that have been detected in the traffic flow between the devices on the SAS loop. A file of historical SAS PHY status data might also be included in the archive. sasPHYStatus.csv</p> |
| Recovery profile | <p>A detailed description of the latest recovery profile record and historical data. recoveryProfile.csv</p> |

| Type of Data | Description and File Name |
|--|--|
| Switch-on-a-chip (SOC) error statistics | Information from the loop-switch ports that are connected to Fibre Channel devices. <code>socStatistics.csv</code> |
| Drive diagnostic data | A detailed list of log sense data from all of the drives in the storage array. <code>driveDiagnosticData.txt</code> |
| State capture data | A detailed description of the current state of the storage array. <code>stateCaptureData.txt</code> |
| Environmental services monitor (ESM) state capture | A detailed description of the current state of the ESMs in a storage array. <code>ESMStateCaptureData.zip</code> |
| Storage array | A detailed listing of the hardware components and the software components that comprise the storage array configuration. <code>storageArrayConfiguration.cfg</code> |
| Unreadable sectors | A detailed list of all of the unreadable sectors that have been logged to the storage array. <code>badBlocksData.txt</code> |
| Firmware inventory | A detailed list of all of the firmware running on the controllers, the drives, the drawers, and the environmental services monitors (ESMs) in the storage array. <code>firmwareInventory.txt</code> |

Collecting Drive Data

To gather information about all of the drives in a storage array, use the `save allDrives` command. This command collects sense data and saves the data to a file. The sense data consists of statistical information that is maintained by each of the drives in the storage array.

Diagnosing a Controller

The `diagnose controller` command provides these tests that help you make sure that a controller is functioning correctly:

- The read test
- The write test
- The data-loopback test

The read test initiates a read command as it would be sent over an I/O data path. The read test compares data with a known, specific data pattern, and the read test checks for data integrity and errors. If the read command is unsuccessful or the data compared is not correct, the controller is considered to be in error and is placed offline.

The write test initiates a write command as it would be sent over an I/O data path to the diagnostics region on a specified drive. This diagnostics region is then read and compared to a specific data pattern. If the write fails or the data compared is not correct, the controller is considered to be in error, and it is failed and placed offline.

Run the data-loopback test only on controllers that have connections between the controller and the drives. The test passes data through each controller drive-side channel, out onto the loop, and back again. Enough data is transferred to determine error conditions on the channel. If the test fails on any channel, this status is saved so that it can be returned if all of the other tests pass.

For best results, run all three tests after you first install the storage array and any time that you that have made changes to the storage array or the components that are connected to the storage array (such as hubs, switches, and host adapters).

A custom data pattern file called `diagnosticsDataPattern.dpf` is included in the root directory of the installation CD. You can modify this file, but the file must have these properties to work correctly for the tests:

- The file values must be entered in hexadecimal format (00 to FF) with only one space between the values.
- The file must be no larger than 64 bytes in size. Smaller files will work, but larger files can cause an error.

The test results contain a generic, overall status message and a set of specific test results. Each test result contains these items:

- Test (read, write, or data loopback)
- Port (read or write)
- Level (internal or external)
- Status (pass or fail)

Events are written to the Event Log when the diagnostics are started and when testing is completed. These events help you to evaluate whether diagnostics testing was successful or failed and the reason for the failure.

Running Read Link Status Diagnostics

Read link status (RLS) error counts refer to link errors that have been detected in the traffic flow of a Fibre Channel loop. The errors detected are represented as a count (32-bit field) of error occurrences that are accumulated over time. The counts provide coarse measure of the integrity of the components and devices on the loop. By analyzing the error counts that are retrieved, you can determine the components or devices within the Fibre Channel loop that might be experiencing problems communicating with the other devices on the loop. A high error count for a particular component or device indicates that it might be experiencing problems and should be given immediate attention.

Error counts are calculated from the current baseline. The baseline describes the error count values for each type of device in the Fibre Channel loop, either when the controller goes through its start-of-day sequence or when you reset the baseline. The baseline indicates the difference in error counts from the time the baseline was established to the time you request the read link status data.

The script command set provides two commands for running RLS diagnostics:

- **reset storageArray RLSBaseline** – Resets the RLS baseline for all devices by setting all of the counts to 0.
- **save storageArray RLSCounts** – Saves the RLS counters to a file that you can review later. The default file name is `readLinkStatus.csv`.

Run the `reset storageArray RLSBaseline` command before you run the `save storageArray RLSBaseline` command.

The following table lists the type of data contained by the file that is generated by the `save storageArray RLSBaseline` command.

RLS Baseline Data for the Storage Array

| Type of Data | Description |
|---------------------------------|--|
| Devices | A list of all devices on the Fibre Channel loop. The devices appear in channel order. Within each channel, the devices are sorted according to the device position in the loop. |
| Baseline time | The date and time when the baseline was set. |
| Elapsed time | The time that has elapsed from when the baseline time was set to when the read link status was gathered. |
| Invalid transmission word (ITW) | The total number of ITW errors that were detected on the Fibre Channel loop from the baseline time to the current date and time. ITW might also be referred to as the Received Bad Character Count. ITW counts indicate that in decoding a read/write transmission, the mapping did not exist and the running disparity of the transmission word is invalid. This data is the key error count to be used when analyzing the error count data. |
| Link failure (LF) | The total number of LF errors that were detected on the Fibre Channel loop from the baseline time to the current date and time. An LF condition is either a link fault signal, a loss of signal, or a loss of synchronization condition. The LF signal indicates a failure with the media module laser operation. |
| Loss of synchronization (LOS) | The total number of LOS errors that were detected on the Fibre Channel loop from the baseline time to the current date and time. LOS errors indicate that the receiver cannot acquire symbol lock with the incoming data stream due to a degraded input signal. If this condition persists, the number of LOS errors increases. |
| Loss of signal (LOSG) | The total number of LOSG errors that were detected on the Fibre Channel loop from the baseline date to the current date and time. LOSG errors typically indicate a loss of signal from the transmitting node or the physical component within the Fibre Channel loop. Physical components where a loss of signal typically occurs include the gigabit interface converters (GBICs), the Small Form-factor Pluggable (SFP) transceivers, and the Fibre Channel fiber-optic cable. |

| Type of Data | Description |
|--|---|
| Primitive sequence protocol (PSP) | <p>The total number of PSP errors that were detected on the Fibre Channel loop from the baseline date to the current date and time. PSP refers to the number of N_Port protocol errors that were detected and Link Reset Response (LRR) primitive sequences that were received while the link is up. An LRR is issued by another N_Port in response to a link reset.</p> <p>An N_Port is a Fibre Channel-defined port at the end of a link, such as a server or a workstation. Each port can act as an originator or a responder (or both) and contains a transmitter and receiver. Each port is given a unique name, called an N_Port or an N_Port identifier. If an N_Port is connected to a loop, it becomes an NL_Port. An NL_Port is a Fibre Channel controller ID in a hexadecimal number. The hexadecimal number varies depending on the topology:</p> <ul style="list-style-type: none"> ▪ For a private arbitrated loop, the ID is a 1-byte arbitrated loop physical address (ALPA). ▪ For all other arbitrated loops, it appears as a single 24-bit hexadecimal number (a triplet of domain, area, and ALPA where each field is 1 byte). ▪ For fabric and point-to-point, the ID is a 3-byte hexadecimal number used in the DID and SID (destination identifier and source identifier) fields of Fibre Channel frames. |
| Invalid cyclic redundancy check (ICRC) | <p>The total number of ICRC errors that were detected on the Fibre Channel loop from the baseline date to the current date and time.</p> <p>An ICRC count indicates that a frame has been received with an invalid cyclic redundancy check value. A cyclic redundancy check reads the data, calculates the cyclic redundancy check character, and compares the calculated cyclic redundancy check character with a cyclic check character already present in the data. If they are equal, the new data is presumed to be the same as the old data. If the calculated characters and the old characters do not match, an error is posted, and the data is re-sent.</p> |

Interpreting the RLS Results

The way that you interpret the RLS results is based on the concept that the device immediately following the problematic component will have the largest number of invalid transition word (ITW) error counts. The process is to obtain the ITW count for every component and device on the loop, analyze the data in loop order, and identify any large increases in the ITW counts.



IMPORTANT The current error counting standard for when to calculate the ITW error count is not well defined. Different vendor devices calculate at different rates. Analysis of the data must take this discrepancy into consideration.

Collecting Switch-on-a-Chip Error Statistics

Switch-on-a-chip (SOC) error statistics provide information about the loop-switch ports that are connected to the Fibre Channel devices in a storage array. (RLS counts provide information about the Fibre Channel devices.) Reporting SOC error statistics is available only on storage arrays that have SOC loop-switch devices that are incorporated into the controller drive channel or the ESM circuitry. SOC devices are integrated circuits that join together Fibre Channel devices in arbitrated loop topologies. SOC devices automatically collect statistical information for each SOC port that is connected to a controller port, an ESM port, a drive port, or an expansion connector. Your Customer and Technical Support representative can use the statistical information with RLS counts to identify problems with Fibre Channel devices that are attached to the loop.

SOC error statistics include this information:

- The port state
- The port insertion count
- The loop state
- The loop up count
- The CRC error count
- The relative frequency drift error average
- The loop cycle count
- The operating system (OS) error count
- The port connections attempted count
- The port connections held off count
- The port utilization

The method for collecting error statistics starts by establishing a baseline for the SOC error statistics. The baseline consists of SOC error statistics that are established at a set time for each SOC device on the loop. The baseline is set by clearing the error counters in each SOC device. You can set a device baseline by performing one of these actions:

- Turning on the power to the device or resetting the device
- Running the `reset storageArray SOCBaseline` command

In addition, each controller also initializes the SOC error counters in all of the drive trays that are attached to the controller following a cold boot (power-on or hot insertion). If you add a drive tray while the power is turned on to the storage array, a new baseline is established for any device on the drive tray.

After you have established the baseline for the SOC devices, you run the storage array for a predetermined amount of time (for example, two hours). At the end of the run time, you collect the SOC error statistics by saving the information to a file. To save the information, run the `save storageArray SOCCounts file filename` command. The default name of the file that contains the SOC error statistics is `socStatistics.csv`. You can use any file name that has the `.csv` extension.

Analyzing the SOC error statistics is beyond the scope of normal storage array management. After you have collected the SOC error statistics in a file, send the file to your Customer and Technical Support representative.

Recovery Operations

Recovery operations include repairing the storage array and returning it to an operational state. This might involve replacing a failed canister, a failed controller, or a drive or restoring data or the storage array to operation. For information about when it is appropriate to replace a canister, see “[Routine Maintenance](#).”

Setting the Controller Operational Mode

A controller has three operational modes:

- Online
- Offline
- Service

Placing a controller online sets it to the Optimal state and makes it active and available for I/O operations. Placing a controller offline makes it unavailable for I/O operations and moves its volume groups to the other controller if failover protection is enabled.

Taking a controller offline can seriously impact data integrity and storage array operation.

- If you do not use write cache mirroring, data in the cache of the controller you place offline is lost.
- If you take a controller offline and you have controller failover protection through a host multi-path driver, the other controller in the pair takes over. Volume groups and their associated volumes that were assigned to the offline controller are automatically reassigned to the remaining controller. If you do not have a multi-path driver installed on the application host and you take a controller offline while the application is using associated volumes, application errors will occur.



ATTENTION Possible loss of data access – Placing a controller offline can cause loss of data.

Use Service mode to replace canisters, such as a controller. Placing a controller in Service mode makes it unavailable for I/O operations and moves its volume groups to the second controller without affecting the preferred path of the volume group. This action might significantly reduce performance. The volume groups are automatically transferred back to the preferred controller when it is placed back online.

If you change a controller to Service mode while an application is using the associated volumes on the controller, the change causes I/O errors unless a multi-path driver is installed on the host. Before you place a controller in Service mode, make sure that the volumes are not in use, or a multi-path driver is installed on all of the hosts that are using these volumes.

In addition, if you do not have a multi-path driver, you must make appropriate operating system-specific modifications to make sure that the volume groups moved are accessed on the new path when you change to Service mode.



IMPORTANT Place a controller in Service mode only under the direction of a Customer and Technical Support representative.

To change the operational mode of a controller, use this command:

```
set controller [(a | b)] availability=(online | offline | serviceMode)
```

Changing the Controller Ownership

You can change which controller is the owner of a volume by using the `set volume` command. The command takes this form:

```
set (allVolumes | volume [volumeName] |  
volumes [volumeName1 ... volumeNameN] |  
volume <wwID>) owner=(a | b)
```

Initializing a Drive



ATTENTION Possible loss of data access – When you initialize a drive, all data on the drive is lost.

You must initialize a drive when you have moved a drive that was previously part of a multidisk volume group from one storage array to another. If you do not move the entire set of drives, the volume group information and the volume information on the drives that you move are incomplete. Each drive that you move contains only part of the information that is defined for the volume and the volume group. To be able to reuse the drives to create a new volume group and volume, you must delete all of the old information from the drives by initializing the drive.

When you initialize a drive, all of the old volume group information and volume information are deleted, and the drive is returned to an unassigned state. Returning a drive to an unassigned state adds unconfigured capacity to a storage array. You can use this capacity to create additional volume groups and volumes.

To initialize a drive, use this command:

```
start drive [trayID,slotID] initialize
```

In this command, *trayID* and *slotID* are the identifiers for the drive.

Reconstructing a Drive

If two or more of the drives in a volume group have failed, the volume shows a status of Failed. All of the volumes in the volume group are no longer operating. To return the volume group to an Optimal status, you must replace the failed drives. Then, you must reconstruct the data on the new drives. The data that you reconstruct is the data as it would appear on the failed drives.



IMPORTANT You can use this command only when the drive is assigned to a RAID Level 1, RAID Level 3, RAID Level 5, or RAID Level 6 volume group.

To reconstruct a drive, use this command:

```
start drive [trayID,slotID] reconstruct
```

In this command, *trayID* and *slotID* are the identifiers for the drive.

Initializing a Volume



ATTENTION Possible loss of data access – When you initialize a volume, all data on the volume and all of the information about the volume are destroyed.

A volume is automatically initialized when you first create it. If the volume starts showing failures, you might be required to re-initialize the volume to correct the failure condition.

Consider these restrictions when you initialize a volume:

- You cannot cancel the operation after it begins.
- You cannot use this option if any modification operations are in progress on the volume or the volume group.
- You cannot change the cache parameters of the volume while the initialization operation is in progress.

To initialize a volume, use this command:

```
start volume [volumeName] initialize
```

where *volumeName* is the identifier for the volume.

Redistributing Volumes

When you redistribute volumes, you return the volumes to their preferred controller owners. The preferred controller ownership of a volume or a volume group is the controller of an active-active pair that is designated to own the volumes. The preferred owner for a volume is initially designated when the volume is created. If the preferred controller is being replaced or undergoing a firmware download, ownership of the volumes is automatically shifted to the other controller. That controller becomes the current owner of the volumes. This change is considered to be a routine ownership change and is reported in the Event Log.

To redistribute volumes to their preferred controllers, use this command:

```
reset storageArray volumeDistribution
```



IMPORTANT If you run this command without a multi-path driver on the hosts, stop I/O activity to the volumes to prevent application errors.



IMPORTANT You cannot run this command if all of the volumes are currently owned by their preferred controller, or the storage array does not have defined volumes.

Under some host operating systems, you must reconfigure the multi-path host driver. You might also need to make operating system modifications to recognize the new I/O path to the volume.

Replacing Canisters

Beginning with the CE6998 controller tray, components, such as the controller canisters, the power-fan canisters, and the interconnect-battery canisters, have a Service Action Allowed indicator light. This indicator light is a blue LED. The Service Action Allowed indicator light helps to make sure that you do not remove a canister before it is safe to do so.



ATTENTION Possible loss of data access – Never remove a component that has a Service Action Required indicator light on unless the Service Action Allowed indicator light is on.

If a component fails and must be replaced, the Service Action Required indicator light on that canister comes on to indicate that service action is required, provided no data availability dependencies or other conditions exist that dictate the canister should not be removed. The Service Action Allowed indicator light automatically comes on or goes off when conditions change. In most cases, the Service Action Allowed indicator light comes on steadily when the Service Action Required indicator light comes on for the canister.

If the interconnect-battery canister must be replaced, the Service Action Allowed indicator light does not come on automatically. Before the Service Action Allowed indicator light on the interconnect-battery canister can come on, you must place controller canister in slot B into Service mode. This action routes all control and I/O activity through one controller to help make sure that data access is maintained while the interconnect-battery canister is removed. The Service Action Allowed indicator light comes on after the new canister has been installed.

The ability to remove a canister depends on the data availability dependencies of the controller tray or the controller-drive tray. The Service Action Allowed indicator light does not come on if removing a canister jeopardizes data on the drive trays or current I/O activity. An example of limiting when you can remove a canister is when one controller canister has a Service Action Required indicator light on. You cannot remove the other controller canister (the Service Action Allowed indicator light does not come on), because doing so would jeopardize the data either on the drive trays or transitioning through the controllers.

A less obvious example is when the power supply for the controller canister in slot A has failed, and the controller canister in slot B has failed. Removing the controller canister in slot B before replacing the failed power-fan canister causes the controller canister in slot A to lose power, which results in a loss of data access. This action occurs because power distribution from each power-fan canister is through the controller canister that is physically connected to that power-fan canister.

So, in the preceding example, these actions occur:

- The power-fan canister has both its Service Action Required indicator light and its Service Action Allowed indicator light on.
- The controller canister in slot B has only its Service Action Required indicator light on, but its Service Action Allowed indicator light is off.
- After the failed power-fan canister has been replaced, the Service Action Allowed indicator light comes on for the controller canister in slot B.

The following table shows when the Service Action Allowed indicator light does not come on for each canister (the indicator light is suppressed). An **X** in a table cell indicates that service is not allowed, therefore the Service Action Allowed light does not come on. For example, if the power supply in the power-fan canister in slot A has failed, then replacement of the controller canister in slot B, the interconnect-battery canister, or the power-fan canister in slot B is not allowed, which is indicated when the Service Action Allowed indicator light stays off for those canisters.

Service Action Not Allowed

| Description of Failure or Circumstance | Canister Description | | | | |
|---|----------------------|----------------------|----------------------|---------------------|---------------------|
| | Controller in Slot A | Controller in Slot B | Interconnect Battery | Power-Fan in Slot A | Power-Fan in Slot B |
| The controller canister in slot A has failed or is locked down | | X | X | | |
| The controller canister in slot B has failed or is locked down | X | | | | |
| The controller canister in the slot A drive path is unavailable | | X | X | | |

| Description of Failure or Circumstance | Canister Description | | | | |
|---|----------------------|----------------------|----------------------|---------------------|---------------------|
| | Controller in Slot A | Controller in Slot B | Interconnect Battery | Power-Fan in Slot A | Power-Fan in Slot B |
| The controller canister in the slot B drive path is unavailable | X | | X | | |
| The power supply in the power-fan canister in slot A has failed | | X | X | | X |
| A fan in the power-fan canister in slot A has failed | | | | | |
| The power supply in the power-fan canister in slot B has failed | X | | X | X | |
| A fan in the power-fan canister in slot B has failed | | | | | |
| The interconnect-battery canister has been removed | X | | | X | |
| The controller canister in slot A has been removed | | X | X | | X |
| The controller canister in slot B has been removed | X | | | X | |
| The power-fan canister in slot A has been removed | | X | X | | X |
| The power-fan canister in slot B has been removed | X | | X | X | |
| The battery pack has failed | | | | | |
| The battery pack has been removed | | | | | |

Examples of Information Returned by the Show Commands

This appendix provides examples of information that is returned by the `show` commands. These examples show the type of information and the information detail. This information is useful in determining the components, features, and identifiers that you might need when you configure or maintain a storage array.

Show Storage Array

The `show storageArray` command returns information about the components and the features in a storage array. If you run the command with the `profile` parameter, the command returns information in the form shown by this example. This information is the most detailed report that you can receive about the storage array. After you have configured a storage array, save the configuration description to a file as a reference.

```
Storage array profile
PROFILE FOR STORAGE ARRAY: example9 (x/xx/xx 1:06:05 PM)

SUMMARY-----
Number of controllers: 1
Number of volume groups: 1
Total number of volumes (includes an access volume): 5 of 2048 used
  Number of standard volumes: 2
  Number of access volumes: 1
  Number of mirror repositories: 2
  Number of snapshot repositories: 0
Number of snapshot volumes: 0
Number of mirrored pairs: 0 of 64 used
Number of copies: 0
Number of drives: 9
Supported drive types: Fibre (9)
Total hot spare drives: 0
  Standby: 0
  In use: 0
Access volume: LUN 7 (see Mappings section for details)
Default host type: Linux (Host type index 6)
Current configuration
  Firmware version: PkgInfo 96.10.21.00
  NVSRAM version: N4884-610800-001
Pending configuration
  Staged firmware download supported?: No
  Firmware version: Not applicable
  NVSRAM version: Not applicable
  Transferred on: Not applicable
NVSRAM configured for batteries?: Yes
Start cache flushing at (in percentage): 80
Stop cache flushing at (in percentage): 80
Cache block size (in KB): 4
Media scan frequency (in days): Disabled
Failover alert delay (in minutes): 5
Feature enable identifier: 1234567891011121314151617181ABCD
```

```
CONTROLLERS-----
Number of controllers: 1

Controller in Slot A
Status: Online
Current configuration
  Firmware version: 96.10.21.00
  Appware version: 96.10.21.00
  Bootware version: 96.10.21.00
  NVSRAM version: N4884-610800-001
Pending configuration
  Firmware version: Not applicable
  Appware version: Not applicable
  Bootware version: Not applicable
  NVSRAM version: Not applicable
  Transferred on: Not applicable
Board ID: 4884
Product ID: INF-01-00
Product revision: 9610
Serial number: 1T14148766
Date of manufacture: October 14, 2001
Cache/processor size (MB): 1024/128
Date/Time: Fri Feb 13 13:06:05 MST 2004
Associated Volumes (* = Preferred Owner):
  1*, CTL 0 Mirror Repository*, Mirror Repository 1*, Primary_Volume*
Ethernet port: 1
  MAC address: 00:a0:b8:0c:c3:f5
  Host name: ausctlr9
  Network configuration: Static
  IP address: 172.22.4.249
  Subnet mask: 255.255.255.0
  Gateway: 172.22.4.1
  Remote login: Enabled

Drive interface: Fibre
Channel: 1
Current ID: 125/0x1
Maximum data rate: 2 Gbps
Current data rate: 1 Gbps
Data rate control: Switch
Link status: Up
Drive interface: Fibre
Channel: 2
Current ID: 125/0x1
Maximum data rate: 2 Gbps
Current data rate: 1 Gbps
Data rate control: Switch
Link status: Up
Drive interface: Fibre
Channel: 3
Current ID: 125/0x1
Maximum data rate: 2 Gbps
Current data rate: 1 Gbps
Data rate control: Switch
Link status: Up
Drive interface: Fibre
Channel: 4
Current ID: 125/0x1
Maximum data rate: 2 Gbps
Current data rate: 1 Gbps
Data rate control: Switch
Link status: Up
```

```
Host interface: Fibre
  Port: 1
  Current ID: Not applicable/0xFFFFFFFF
  Preferred ID: 126/0x0
  NL-Port ID: 0x011100
  Maximum data rate: 2 Gbps
  Current data rate: 1 Gbps
  Data rate control: Switch
  Link status: Up
  Topology: Fabric Attach
  World-wide port name: 20:2c:00:a0:b8:0c:c3:f6
  World-wide node name: 20:2c:00:a0:b8:0c:c3:f5
  Part type: HPFC-5200    revision 10
Host interface: Fibre
  Port: 2
  Current ID: Not applicable/0xFFFFFFFF
  Preferred ID: 126/0x0
  NL-Port ID: 0x011000
  Maximum data rate: 2 Gbps
  Current data rate: 1 Gbps
  Data rate control: Switch
  Link status: Up
  Topology: Fabric Attach
  World-wide port name: 20:2c:00:a0:b8:0c:c3:f7
  World-wide node name: 20:2c:00:a0:b8:0c:c3:f5
  Part type: HPFC-5200    revision 10

VOLUME GROUPS-----
  Number of volume groups: 1

  Volume Group 1 (RAID 5)
  Status: Online
  Drive type: Fibre Channel
  Tray loss protection: No
  Current owner: Controller in slot A
  Associated volumes and free capacities:
    CTL 0 Mirror Repository (0.125 GB), Mirror Repository 1 (0.125 GB),
    Primary_Volume (5 GB), 1 (1 GB), Free Capacity (129.113 GB)
  Associated drives (in piece order):
    Drive at Tray 0, Slot 1
    Drive at Tray 0, Slot 2
    Drive at Tray 0, Slot 3
    Drive at Tray 0, Slot 5
    Drive at Tray 0, Slot 6
    Drive at Tray 0, Slot 7
    Drive at Tray 0, Slot 10
    Drive at Tray 0, Slot 12
    Drive at Tray 0, Slot 14
```

STANDARD VOLUMES-----

SUMMARY

Number of standard volumes: 2
 See other volumes sub-tabs for premium feature information.

| NAME | STATUS | CAPACITY | RAID LEVEL | VOLUME GROUP |
|----------------|---------|----------|------------|--------------|
| 1 | Optimal | 1 GB | 5 | 1 |
| Primary_Volume | Optimal | 5 GB | 5 | 1 |

DETAILS

Volume name: 1
 Volume ID: 60:0a:0b:80:00:0c:c3:f5:00:00:00:23:40:22:86:ea
 Subsystem ID (SSID): 3
 Status: Optimal
 Drive type: Fibre Channel
 Tray loss protection: No
 Preferred owner: Controller in slot A
 Current owner: Controller in slot A
 Capacity: 1 GB
 RAID level: 5
 Segment size: 64 KB
 Modification priority: High
 Associated volume group: 1
 Read cache: Enabled
 Write cache: Enabled
 Write cache without batteries: Disabled
 Write cache with mirroring: Enabled
 Flush write cache after (in seconds): 10.00
 Cache read ahead multiplier: 1
 Enable background media scan: Disabled
 Media scan with redundancy check: Disabled

Volume name: Primary_Volume
 Volume ID: 60:0a:0b:80:00:0c:c3:f5:00:00:00:1c:40:22:45:ca
 Subsystem ID (SSID): 2
 Status: Optimal
 Drive type: Fibre Channel
 Tray loss protection: No
 Preferred owner: Controller in slot A
 Current owner: Controller in slot A
 Capacity: 5 GB
 RAID level: 5
 Segment size: 64 KB
 Modification priority: High
 Associated volume group: 1
 Read cache: Enabled
 Write cache: Enabled
 Write cache without batteries: Disabled
 Write cache with mirroring: Enabled
 Flush write cache after (in seconds): 10.00
 Cache read ahead multiplier: 1
 Enable background media scan: Disabled
 Media scan with redundancy check: Disabled

SNAPSHOT REPOSITORY VOLUMES-----
 Number of snapshot repositories: 0

MIRROR REPOSITORY VOLUMES-----
 Number of mirror repositories: 0

SNAPSHOT VOLUMES-----
 Number of snapshot volumes: 0

MIRRORED PAIRS-----

SUMMARY
 Number of mirrored pairs: 0 of 64 used
 See also Standard sub-tab for standard volume properties

COPIES-----

SUMMARY
 Number of copies: 0
 See also Standard sub-tab for standard volume properties

MISSING VOLUMES-----
 Number of missing volumes: 0
 See other Volumes sub-tabs for premium feature information

DRIVES-----

SUMMARY
 Number of drives: 9
 Supported drive types: Fibre (9)

BASIC:

| TRAY, SLOT | STATUS | CAPACITY | CURRENT DATA RATE | PRODUCT ID | FIRMWARE VERSION |
|------------|---------|-----------|-------------------|------------|------------------|
| 0, 1 | Optimal | 16.959 GB | 1 Gbps | ST318451FC | F28D |
| 0, 2 | Optimal | 16.959 GB | 1 Gbps | ST318451FC | F28D |
| 0, 3 | Optimal | 16.959 GB | 1 Gbps | ST318451FC | F28D |
| 0, 5 | Optimal | 16.959 GB | 1 Gbps | ST318451FC | F28D |
| 0, 6 | Optimal | 16.959 GB | 1 Gbps | ST318451FC | F28D |
| 0, 7 | Optimal | 16.959 GB | 1 Gbps | ST318451FC | F28D |
| 0, 10 | Optimal | 16.959 GB | 1 Gbps | ST318451FC | F28D |
| 0, 12 | Optimal | 16.959 GB | 1 Gbps | ST318451FC | F28B |
| 0, 14 | Optimal | 16.959 GB | 1 Gbps | ST318451FC | F28B |

DRIVE CHANNELS:

| TRAY, SLOT | PREFERRED CHANNEL | REDUNDANT CHANNEL |
|------------|-------------------|-------------------|
| 0, 1 | 4 | 2 |
| 0, 2 | 2 | 4 |
| 0, 3 | 4 | 2 |
| 0, 5 | 4 | 2 |
| 0, 6 | 2 | 4 |
| 0, 7 | 4 | 2 |
| 0, 10 | 2 | 4 |
| 0, 12 | 2 | 4 |
| 0, 14 | 2 | 4 |

HOT SPARE COVERAGE:

The following volume groups are not protected: 1

Total hot spare drives: 0

Standby: 0

In use: 0

DETAILS

Drive at Tray 0, Slot 1

Drive port: 1, Channel: 4, ID: 0/0xEF

Drive port: 2, Channel: 2, ID: 0/0xEF

Drive path redundancy: OK

Status: Optimal

Raw capacity: 16.959 GB

Usable capacity: 16.92 GB

Current data rate: 1 Gbps

Product ID: ST318451FC

Firmware version: F280

Serial number: 3CC052RK00007116BMW7

Vendor: SEAGATE

Date of manufacture: July 19, 2001

World-wide name: 20:00:00:20:37:f5:b3:b6

Drive type: Fibre Channel

Speed: 15015 RPM

Mode: Assigned

Associated volume group: volume group 1

Drive at Tray 0, Slot 2

Drive port: 1, Channel: 2, ID: 1/0xE8

Drive port: 2, Channel: 4, ID: 1/0xE8

Drive path redundancy: OK

Status: Optimal

Raw capacity: 16.959 GB

Usable capacity: 16.92 GB

Current data rate: 1 Gbps

Product ID: ST318451FC

Firmware version: F280

Serial number: 3CC0Q06K0000720291J9

Vendor: SEAGATE

Date of manufacture: July 18, 2001

World-wide name: 20:00:00:20:37:f5:ac:cd

Drive type: Fibre Channel

Speed: 15015 RPM

Mode: Assigned

Associated volume group: volume group 1

Drive at Tray 0, Slot 3

Drive port: 1, Channel: 4, ID: 2/0xE4

Drive port: 2, Channel: 2, ID: 2/0xE4

Drive path redundancy: OK

Status: Optimal

Raw capacity: 16.959 GB

Usable capacity: 16.92 GB

Current data rate: 1 Gbps

Product ID: ST318451FC

Firmware version: F280

Serial number: 3CC052MA00007116DB89

Vendor: SEAGATE

Date of manufacture: July 19, 2001

World-wide name: 20:00:00:20:37:f5:b3:fc

Drive type: Fibre Channel

Speed: 15015 RPM

Mode: Assigned

Associated volume group: volume group 1

Drive at Tray 0, Slot 5
Drive port: 1, Channel: 4, ID: 4/0xE1
Drive port: 2, Channel: 2, ID: 4/0xE1
Drive path redundancy: OK
Status: Optimal
Raw capacity: 16.959 GB
Usable capacity: 16.92 GB
Current data rate: 1 Gbps
Product ID: ST318451FC
Firmware version: F28D
Serial number: 3CC0526N00007143A10K
Vendor: SEAGATE
Date of manufacture: July 19, 2001
World-wide name: 20:00:00:20:37:f5:b4:5b
Drive type: Fibre Channel
Speed: 15015 RPM
Mode: Assigned
Associated volume group: Volume group 1

Drive at Tray 0, Slot 6
Drive port: 1, Channel: 2, ID: 5/0xE0
Drive port: 2, Channel: 4, ID: 5/0xE0
Drive path redundancy: OK
Status: Optimal
Raw capacity: 16.959 GB
Usable capacity: 16.92 GB
Current data rate: 1 Gbps
Product ID: ST318451FC
Firmware version: F28D
Serial number: 3CC03R5800007112JU2D
Vendor: SEAGATE
Date of manufacture: July 19, 2001
World-wide name: 20:00:00:20:37:f5:b3:06
Drive type: Fibre Channel
Speed: 15015 RPM
Mode: Assigned
Associated volume group: Volume group 1

Drive at Tray 0, Slot 7
Drive port: 1, Channel: 4, ID: 6/0xDC
Drive port: 2, Channel: 2, ID: 6/0xDC
Drive path redundancy: OK
Status: Optimal
Raw capacity: 16.959 GB
Usable capacity: 16.92 GB
Current data rate: 1 Gbps
Product ID: ST318451FC
Firmware version: F28D
Serial number: 3CC052J400007116BSJV
Vendor: SEAGATE
Date of manufacture: July 19, 2001
World-wide name: 20:00:00:20:37:f5:b3:0b
Drive type: Fibre Channel
Speed: 15015 RPM
Mode: Assigned
Associated volume group: Volume group 1

Drive at Tray 0, Slot 10
Drive port: 1, Channel: 2, ID: 96/0x3A
Drive port: 2, Channel: 4, ID: 96/0x3A
Drive path redundancy: OK
Status: Optimal
Raw capacity: 16.959 GB
Usable capacity: 16.92 GB
Current data rate: 1 Gbps
Product ID: ST318451FC
Firmware version: F28D
Serial number: 3CC0P5Q80000711552CZ
Vendor: SEAGATE
Date of manufacture: June 30, 2001
World-wide name: 20:00:00:20:37:f5:69:50
Drive type: Fibre Channel
Speed: 15015 RPM
Mode: Assigned
Associated volume group: Volume group 1

Drive at Tray 0, Slot 12
Drive port: 1, Channel: 2, ID: 72/0x67
Drive port: 2, Channel: 4, ID: 72/0x67
Drive path redundancy: OK
Status: Optimal
Raw capacity: 16.959 GB
Usable capacity: 16.92 GB
Current data rate: 1 Gbps
Product ID: ST318451FC
Firmware version: F28B
Serial number: 3CC0P7TS00007116DL9D
Vendor: LSILOGIC
Date of manufacture: Not available
World-wide name: 20:00:00:20:37:f5:68:76
Drive type: Fibre Channel
Speed: 15015 RPM
Mode: Assigned
Associated volume group: Volume group 1

Drive at Tray 0, Slot 14
Drive port: 1, Channel: 2, ID: 104/0x2E
Drive port: 2, Channel: 4, ID: 104/0x2E
Drive path redundancy: OK
Status: Optimal
Raw capacity: 16.959 GB
Usable capacity: 16.92 GB
Current data rate: 1 Gbps
Product ID: ST318451FC
Firmware version: F28B
Serial number: 3CC03STH00007112JNM4
Vendor: LSILOGIC
Date of manufacture: Not available
World-wide name: 20:00:00:20:37:f5:b3:69
Drive type: Fibre Channel
Speed: 15015 RPM
Mode: Assigned
Associated volume group: Volume group 1

DRIVE CHANNEL INFORMATION - Channel 1

SUMMARY-----

Channel 1 status: Optimal
Controller A link status: Up

CUMULATIVE ERROR COUNTS-----

Controller A Cumulative Error Counts
Baseline time set: 2/9/04 10:46:37 AM
Sample period (days, hh:mm:ss): 4 days, 02:06:52
Controller detected errors: 0
Drive detected errors: 0
Timeout errors: 0
Link down errors: 3
Total I/O count: 11

DRIVE CHANNEL INFORMATION - Channel 2

SUMMARY-----

Channel 2 status: Optimal
Controller A link status: Up

CUMULATIVE ERROR COUNTS-----

Controller A Cumulative Error Counts
Baseline time set: 2/9/04 10:46:42 AM
Sample period (days, hh:mm:ss): 4 days, 02:06:47
Controller detected errors: 0
Drive detected errors: 0
Timeout errors: 0
Link down errors: 2
Total I/O count: 239075

DRIVE CHANNEL INFORMATION - Channel 3

SUMMARY-----

Channel 3 status: Optimal
Controller A link status: Up

CUMULATIVE ERROR COUNTS-----

Controller A Cumulative Error Counts
Baseline time set: 2/9/04 10:46:42 AM
Sample period (days, hh:mm:ss): 4 days, 02:06:47
Controller detected errors: 0
Drive detected errors: 0
Timeout errors: 0
Link down errors: 3
Total I/O count: 11

DRIVE CHANNEL INFORMATION - Channel 4

SUMMARY-----

Channel 4 status: Optimal
Controller A link status: Up

CUMULATIVE ERROR COUNTS-----

Controller A Cumulative Error Counts
Baseline time set: 2/9/04 10:46:42 AM
Sample period (days, hh:mm:ss): 4 days, 02:06:47
Controller detected errors: 0
Drive detected errors: 0
Timeout errors: 0
Link down errors: 2
Total I/O count: 45807

```
TRAYS-----
Controller Tray Overall Component Information
Drive technology: Unknown
Minihub data rate mismatch: No
Fan canister: Optimal
Fan canister: Optimal
Battery status: Optimal
  Age: 0 day(s)
  Days until replacement: 719 day(s)
Power supply canister
  Status: Optimal
Power supply canister
  Status: Optimal
Temperature: Optimal
Host mini-hub canister
  Status: Optimal
  Location: Controller A - Port 1
  Serial number: SN 1T13742151
  Part number: PN 348-0043290
  Vendor: VN LSILOGIC
  Date of manufacture: Not available
SFP
  Status: Optimal
  Location: In connection
  Supported data rate(s): 1 Gbps, 2 Gbps
  Link length: Intermediate
  Connector: LC
  Transmitter type: Shortwave Laser w/o OFC
  Transmission media: TM Multi-mode 50m(M5) TM Multi-mode 62.5m(M6)
  IEEE company ID: 08 00 5a
  Revision: AA10
  Part number: IBM42P21SNY
  Serial number: 21P7053000M6R
  Vendor: IBM
  Date of manufacture: July 1, 2001
SFP
  Status: Optimal
  Location: Out connection
  Supported data rate(s): 1 Gbps, 2 Gbps
  Link length: Intermediate
  Connector: LC
  Transmitter type: Shortwave Laser w/o OFC
  Transmission media: TM Multi-mode 50m(M5) TM Multi-mode 62.5m(M6)
  IEEE company ID: 08 00 5a
  Revision: AA10
  Part number: IBM42P21SNY
  Serial number: 21P7053000M54
  Vendor: IBM
  Date of manufacture: July 1, 2001
```

```
Host mini-hub canister
Status: Optimal
Location: Controller A - Port 2
Serial number: SN 1T13742219
Part number: PN 348-0043290
Vendor: VN LSILOGIC
Date of manufacture: Not available
SFP
  Status: Optimal
  Location: In connection
  Supported data rate(s): 1 Gbps, 2 Gbps
  Link length: Intermediate
  Connector: LC
  Transmitter type: Shortwave Laser w/o OFC
  Transmission media: TM Multi-mode 50m(M5) TM Multi-mode 62.5m(M6)
  IEEE company ID: 08 00 5a
  Revision: AA10
  Part number: IBM42P21SNY
  Serial number: 21P7053000M3Z
  Vendor: IBM
  Date of manufacture: July 1, 2001
SFP
  Status: Optimal
  Location: Out connection
  Supported data rate(s): 1 Gbps, 2 Gbps
  Link length: Intermediate
  Connector: LC
  Transmitter type: Shortwave Laser w/o OFC
  Transmission media: TM Multi-mode 50m(M5) TM Multi-mode 62.5m(M6)
  IEEE company ID: 08 00 5a
  Revision: AA10
  Part number: IBM42P21SNY
  Serial number: 21P7053000M3J
  Vendor: IBM
  Date of manufacture: July 1, 2001
Drive mini-hub canister
Status: Optimal
Location: Channel 1
Serial number: SN 1T13438343
Part number: PN 348-0043290
Vendor: VN LSILOGIC
Date of manufacture: Not available
SFP
  Status: Optimal
  Location: Out connection
  Supported data rate(s): 1 Gbps, 2 Gbps
  Link length: Intermediate
  Connector: LC
  Transmitter type: Shortwave Laser w/o OFC
  Transmission media: TM Multi-mode 50m(M5) TM Multi-mode 62.5m(M6)
  IEEE company ID: 08 00 5a
  Revision: AA10
  Part number: IBM42P21SNY
  Serial number: 21P7053000M6Z
  Vendor: IBM
  Date of manufacture: July 1, 2001
```

```

Drive mini-hub canister
Status: Optimal
Location: Channel 2
Serial number: SN 1T13844441
Part number: PN 19K1270
Vendor: VN IBM
Date of manufacture: Not available
SFP
  Status: Optimal
  Location: In connection
  Supported data rate(s): 1 Gbps, 2 Gbps
  Link length: Intermediate
  Connector: LC
  Transmitter type: Shortwave Laser w/o OFC
  Transmission media: TM Multi-mode 50m(M5) TM Multi-mode 62.5m(M6)
  IEEE company ID: 08 00 5a
  Revision: AA10
  Part number: IBM42P21SNY
  Serial number: 21P7053000M4E
  Vendor: IBM
  Date of manufacture: July 1, 2001
SFP
  Status: Optimal
  Location: Out connection
  Supported data rate(s): 1 Gbps, 2 Gbps
  Link length: Intermediate
  Connector: LC
  Transmitter type: Shortwave Laser w/o OFC
  Transmission media: TM Multi-mode 50m(M5) TM Multi-mode 62.5m(M6)
  IEEE company ID: 08 00 5a
  Revision: AA10
  Part number: IBM42P21SNY
  Serial number: 21P7053000M40
  Vendor: IBM
  Date of manufacture: July 1, 2001
Drive mini-hub canister
Status: Optimal
Location: Channel 3
Serial number: SN 1T13844373
Part number: PN 348-0043290
Vendor: VN LSILOGIC
Date of manufacture: Not available
SFP
  Status: Optimal
  Location: In connection
  Supported data rate(s): 1 Gbps, 2 Gbps
  Link length: Intermediate
  Connector: LC
  Transmitter type: Shortwave Laser w/o OFC
  Transmission media: TM Multi-mode 50m(M5) TM Multi-mode 62.5m(M6)
  IEEE company ID: 08 00 5a
  Revision: AA10
  Part number: IBM42P21SNY
  Serial number: 21P7053000M4R
  Vendor: IBM
  Date of manufacture: July 1, 2001
SFP
  Status: Optimal
  Location: Out connection
  Supported data rate(s): 1 Gbps, 2 Gbps
  Link length: Intermediate
  Connector: LC
  Transmitter type: Shortwave Laser w/o OFC
  Transmission media: TM Multi-mode 50m(M5) TM Multi-mode 62.5m(M6)
  IEEE company ID: 08 00 5a
  Revision: AA10
  Part number: IBM42P21SNY
  Serial number: 21P7053000LX5
  Vendor: IBM
  Date of manufacture: July 1, 2001

```

Drive mini-hub canister

Status: Optimal
Location: Channel 4
Serial number: SN 1T13844386
Part number: PN 348-0043290
Vendor: VN LSILOGIC
Date of manufacture: Not available
SFP

Status: Optimal
Location: In connection
Supported data rate(s): 1 Gbps, 2 Gbps
Link length: Intermediate
Connector: LC
Transmitter type: Shortwave Laser w/o OFC
Transmission media: TM Multi-mode 50m(M5) TM Multi-mode 62.5m(M6)
IEEE company ID: 08 00 5a
Revision: AA10
Part number: IBM42P21SNY
Serial number: 21P7053000M6E
Vendor: IBM
Date of manufacture: July 1, 2001

SFP

Status: Optimal
Location: Out connection
Supported data rate(s): 1 Gbps, 2 Gbps
Link length: Intermediate
Connector: LC
Transmitter type: Shortwave Laser w/o OFC
Transmission media: TM Multi-mode 50m(M5) TM Multi-mode 62.5m(M6)
IEEE company ID: 08 00 5a
Revision: AA10
Part number: IBM42P21SNY
Serial number: 21P7053000M57
Vendor: IBM
Date of manufacture: July 1, 2001

Drive Tray 0 Overall Component Information

Drive technology: Fibre channel
Part number: PN 348-0042807
Serial number: SN 0146001584
Vendor: VN LSILOGIC
Date of manufacture: November 1, 2001
Tray path redundancy: OK
Fan canister: Optimal
Fan canister: Optimal
Power supply canister
Status: Optimal
Power supply canister
Status: Optimal
Temperature: Optimal
Temperature: Optimal
ESM card

Status: Optimal
Firmware version: 9163
Maximum data rate: 1 Gbps
Current data rate: 1 Gbps
Location: A (left canister)
Card communication: OK
Product ID: SYM2500-FC
Part number: PN 348-0043832
Serial number: SN 1T22941398
Vendor: LSILOGIC
Date of manufacture: July 1, 2002
GBIC
Status: Optimal
Location: In connection
Type: Optical Shortwave

ESM card

Status: Optimal
Firmware version: 9163
Maximum data rate: 1 Gbps
Current data rate: 1 Gbps
Location: B (right canister)
Card communication: OK
Product ID: SYM2500-FC
Part number: PN 348-0043832
Serial number: SN 1T13945863
Vendor: LSILOGIC
Date of manufacture: October 1, 2001
GBIC
Status: Optimal
Location: In connection
Type: Optical Shortwave

```

MAPPINGS (SANshare STORAGE PARTITIONING - ENABLED (0 of 64 used))-----
Volume-To-LUN Mappings
  Access Volume, LUN 7, Default Group

Topology
  [Undefined Host Ports]
    10:00:00:a0:b8:04:29:3f
    21:00:00:e0:8b:01:34:c1
    21:01:00:e0:8b:22:80:38

  [Default Group]

NVSRAM Host Type Internal Definitions
Index 0
  Name: Windows NT Non-Clustered (SP5 or higher)
  AVT status: Disabled
Index 1
  Name: Windows 2000/Server 2003 Non-Clustered
  AVT status: Disabled
Index 2
  Name: Solaris
  AVT status: Disabled
Index 3
  Name: HP-UX
  AVT status: Enabled
Index 4
  Name: AIX
  AVT status: Disabled
Index 5
  Name: Irix
  AVT status: Disabled
Index 6 (DEFAULT)
  Name: Linux
  AVT status: Disabled
Index 7
  Name: Windows NT Clustered (SP5 or higher)
  AVT status: Disabled
Index 8
  Name: Windows 2000/Server 2003 Clustered
  AVT status: Disabled
Index 9
  Name: Netware Non-Failover
  AVT status: Enabled
Index 10
  Name: PTX
  AVT status: Enabled
Index 11
  Name: Netware Failover
  AVT status: Enabled
Index 12
  Name: Solaris (with Veritas DMP)
  AVT status: Enabled

```

Show Controller NVSRAM

The **show controller NVSRAM** command returns a table of values in the controller NVSRAM that is similar to that shown in this example. With the information from the table, you can modify the contents of the NVSRAM by using the **set controller** command. This example shows information for a controller in slot A in a controller tray. You can produce a similar table for a controller in slot B, or you can produce a table for both controllers.

```

Controller "a":
Region 232:
  0000: 0000 0000 0000 0000 0000 0000 0000 0000 .....
  0010: 0000 0000 0000 0000 0000 0000 0000 0000 .....

Region 233:
  0000: 0000 7f8e 0000 1384 ff01 0000 0000 0000 ...?...?.....
  0010: 0000 0000 0000 0000 0000 0000 0000 0000 .....
  0020: 0000 0308 8e08 8108 0000 0000 0000 0408 ...?.?.?.....
  0030: 0220 0220 8920 8820 8d00 0900 0308 0000 ...?.?.?.....
  0040: 0000 0000 0000 0000 0000 0000 0000 0000 .....
  0050: 0000 0000 0000 0000 0000 0000 0000 0000 .....

Region 234:
  0000: 1020 3040 5060 0000 0000 0000 0000 0000 ..0.P.....
  0010: 1121 3141 5161 0000 0000 0000 0000 0000 ..1AQa.....
  0020: 1222 3242 5262 0000 0000 0000 0000 0000 ..2BRb.....
  0030: 1323 3343 5363 0000 0000 0000 0000 0000 ..3CSc.....
  0040: 1424 3444 5464 0000 0000 0000 0000 0000 ..4DTd.....
  0050: 0000 0000 0000 0000 0000 0000 0000 0000 .....
  0060: 0000 0000 0000 0000 0000 0000 0000 0000 .....
  0070: 0000 0000 0000 0000 0000 0000 0000 0000 .....

Region 236:
  0000: 0000 0000 0000 0000 0000 0000 0000 0000 .....
  0010: 0000 0000 0000 0000 0000 0000 0000 0000 .....
  0020: 0000 0000 0000 0000 0000 0000 0000 0000 .....
  0030: 0000 0000 0000 0000 0000 0000 0000 0000 .....
  0040: 0000 0000 0000 0000 0000 0000 0000 0000 .....
  0050: 0000 0000 0000 0000 0000 0000 0000 0000 .....
  0060: 0000 0000 0000 0000 0000 0000 0000 0000 .....
  0070: 0000 0000 0000 0000 0000 0000 0000 0000 .....

Region 237:
  0000: 0000 0000 0000 0000 0000 0000 0000 0000 .....
  0010: 0000 0000 0000 0000 0000 0000 0000 0000 .....

Region 238:
  0000: 0000 ca32 0000 0000 0050 0600 0000 0000 ..?2.....P.....
  0010: 0000 0000 0000 0000 0000 f001 0000 8480 0000 .....??.?..
  0020: 0000 0000 0000 0000 0000 0c04 008a 0000 0000 .....?.....
  0030: 0020 8741 1300 0000 0f00 1400 0000 0000 ..?A.....

```

```

Region 240:
0000: fb01 80fa 0101 0104 ffff ff00 0304 ac16 ..?.....?.
0010: 0401 ab04 ac16 04f9 ac04 ac16 04c8 0c08 ..?.?...??.
0020: 6175 7363 746c 7239 a013 616e 7461 7265 ausctlr9?.antare
0030: 732e 6b73 2e6c 7369 6c2e 636f 6da1 076a s.ks.lsil.com?.j
0040: 6761 7469 6361 a20b 6171 7561 3a6d 6172 gatica?.aqua.mar
0050: 696e 6511 012f b101 0ab0 0218 47ff 0000 ine...?...?..G...
0060: 0000 0000 0000 0000 0000 0000 0000 0000 .....
0070: 0000 0000 0000 0000 0000 0000 0000 0000 .....
0080: 0000 0000 0000 0000 0000 0000 0000 0000 .....
0090: 0000 0000 0000 0000 0000 0000 0000 0000 .....
00a0: 0000 0000 0000 0000 0000 0000 0000 0000 .....
00b0: 0000 0000 0000 0000 0000 0000 0000 0000 .....
00c0: 0000 0000 0000 0000 0000 0000 0000 0000 .....
00d0: 0000 0000 0000 0000 0000 0000 0000 0000 .....
00e0: 0000 0000 0000 0000 0000 0000 0000 0000 .....
00f0: 0000 0000 0000 0000 0000 0000 0000 0000 .....

Region 241:
0000: 0000 ca32 0000 0000 0050 0600 0000 0000 ..?2.....P.....
0010: 0000 0000 0000 0000 f001 0000 8480 0000 .....??..
0020: 0000 0000 0000 0000 0c04 008a 0000 0000 .....?....
0030: 0020 8741 1300 0000 0f00 1400 0000 0000 ..?A.....
0040: 4465 6661 756c 7400 0000 0000 0000 0000 Default.....
0050: 0000 0000 0000 0000 0000 0000 0000 0000 .....
0060: 0000 0000 0000 0000 0000 0000 0000 0000 .....
0070: 0000 0000 0000 0000 0000 0000 0000 0000 .....
0080: 0000 0000 0000 0000 0000 0000 0000 0000 .....
0090: 0000 0000 0000 0000 0000 0000 0000 0000 .....

Region 242:
0000: 574e 544e 434c 5350 3500 0000 0000 0000 WNTNCLSP5.....
0010: 0000 0000 0100 0000 0000 0000 0000 0000 .....
0020: 0100 0000 0000 0002 0000 0000 0000 0000 .....
0030: 0000 0000 0000 0000 0000 0000 0000 0000 .....

Region 242:
0000: 5732 4b4e 4554 4e43 4c00 0000 0000 0000 W2KNETNCL.....
0010: 0020 0000 0100 0000 0000 0000 0000 0000 .....
0020: 0000 0000 0000 0000 0000 0000 0000 0000 .....
0030: 0000 0000 0000 0000 0000 0000 0000 0000 .....

Region 242:
0000: 534f 4c00 0000 0000 0000 0000 0000 0000 SOL.....
0010: 0120 0000 0100 0000 0001 0000 0000 0000 .....
0020: 0000 0000 0000 0002 0000 0000 0000 0000 .....
0030: 0000 0000 0000 0000 0000 0000 0000 0000 .....

Region 242:
0000: 4850 5800 0000 0000 0000 0000 0000 0000 HPX.....
0010: 0120 0000 0100 0000 0101 0001 0101 0001 .....
0020: 0000 0000 0100 0000 0000 0000 0000 0000 .....
0030: 0000 0000 0000 0000 0000 0000 0000 0000 .....

Region 242:
0000: 4149 5800 0000 0000 0000 0000 0000 0000 AIX.....
0010: 0120 0000 0100 2000 0101 0000 0001 0000 .....
0020: 0000 0100 0000 0001 0000 0000 0000 0000 .....
0030: 0000 0000 0000 0000 0000 0000 0000 0000 .....

Region 242:
0000: 4952 5800 0000 0000 0000 0000 0000 0000 IRX.....
0010: 007f 0000 0100 2000 0000 0000 0000 0000 .....
0020: 0000 0100 0000 0000 0000 0000 0000 0000 .....
0030: 0000 0000 0000 0000 0000 0000 0000 0000 .....
    
```

```

Region 242:
0000: 4c4e 5800 0000 0000 0000 0000 0000 0000 0000  LNK.....
0010: 0120 0000 0100 0000 0001 0000 0000 0000 0000  .....
0020: 0000 0000 0000 0000 0000 0000 0000 0000 0000  .....
0030: 0000 0000 0000 0000 0000 0000 0000 0000 0000  .....

Region 242:
0000: 574e 5443 4c53 5035 0000 0000 0000 0000 0000  WNTCLSP5.....
0010: 0000 0000 0100 0000 0001 0001 0000 0000 0000  .....
0020: 0100 0000 0000 0002 0000 0000 0000 0000 0000  .....
0030: 0000 0000 0000 0000 0000 0000 0000 0000 0000  .....

Region 242:
0000: 5732 4b4e 4554 434c 0000 0000 0000 0000 0000  W2KNETCL.....
0010: 0020 0000 0100 0000 0001 0001 0000 0000 0000  .....
0020: 0000 0000 0000 0000 0000 0000 0000 0000 0000  .....
0030: 0000 0000 0000 0000 0000 0000 0000 0000 0000  .....

Region 242:
0000: 4e57 5200 0000 0000 0000 0000 0000 0000 0000  NWR.....
0010: 007f 0000 0100 2000 0000 0000 0000 0000 0000  .....
0020: 0100 0100 0100 0000 0000 0000 0000 0000 0000  .....
0030: 0000 0000 0000 0000 0000 0000 0000 0000 0000  .....

Region 242:
0000: 5054 5800 0000 0000 0000 0000 0000 0000 0000  PTX.....
0010: 0120 0000 0100 0000 0001 0000 0000 0000 0000  .....
0020: 0100 0000 0100 0000 0000 0000 0000 0000 0000  .....
0030: 0000 0000 0000 0000 0000 0000 0000 0000 0000  .....

Region 242:
0000: 4e57 5246 4f00 0000 0000 0000 0000 0000 0000  NWRFD.....
0010: 007f 0000 0100 0000 0000 0000 0000 0000 0000  .....
0020: 0100 0100 0100 0000 0000 0000 0000 0000 0000  .....
0030: 0000 0000 0000 0000 0000 0000 0000 0000 0000  .....

Region 242:
0000: 534f 4c41 5654 0000 0000 0000 0000 0000 0000  SOLAVT.....
0010: 0120 0000 0100 0000 0001 0100 0000 0000 0000  .....
0020: 0000 0001 0180 0000 0000 0000 0000 0000 0000  .....?.....
0030: 0000 0000 0000 0000 0000 0000 0000 0000 0000  .....

Region 242:
0000: 0000 0000 0000 0000 0000 0000 0000 0000 0000  .....
0010: 0000 0000 0000 0000 0000 0000 0000 0000 0000  .....
0020: 0000 0000 0000 0000 0000 0000 0000 0000 0000  .....
0030: 0000 0000 0000 0000 0000 0000 0000 0000 0000  .....

Region 242:
0000: 0000 0000 0000 0000 0000 0000 0000 0000 0000  .....
0010: 0000 0000 0000 0000 0000 0000 0000 0000 0000  .....
0020: 0000 0000 0000 0000 0000 0000 0000 0000 0000  .....
0030: 0000 0000 0000 0000 0000 0000 0000 0000 0000  .....

Region 242:
0000: 0000 0000 0000 0000 0000 0000 0000 0000 0000  .....
0010: 0000 0000 0000 0000 0000 0000 0000 0000 0000  .....
0020: 0000 0000 0000 0000 0000 0000 0000 0000 0000  .....
0030: 0000 0000 0000 0000 0000 0000 0000 0000 0000  .....

```

Show Volume

The **show volume** command returns information about the volumes in a storage array.

```

STANDARD VOLUMES-----
SUMMARY
Number of standard volumes: 5
See other Volumes sub-tabs for premium feature information.
NAME      STATUS   CAPACITY   RAID LEVEL  VOLUME GROUP  LUN

```

| | | | | | |
|---------|---------|--------------|----|----------------|----|
| 1 | Optimal | 5,120.000 GB | 10 | 6 | 13 |
| 2 | Optimal | 1.000 GB | 1 | Volume-Group-2 | 14 |
| 3 | Optimal | 10.000 GB | 1 | Volume-Group-2 | 15 |
| 4 | Optimal | 3.000 GB | 1 | Volume-Group-2 | 16 |
| Unnamed | Optimal | 100.004 MB | 0 | Volume-Group-1 | 0 |

DETAILS

Volume name: 1

Volume status: Optimal

Capacity: 5,120.000 GB

Volume world-wide identifier: 60:0a:0b:80:00:29:ed:12:00:00

Subsystem ID (SSID): 14

Associated volume group: 6

RAID level: 10

LUN: 13

Accessible By: Default Group

Media type: Hard Disk Drive

Interface type: Serial ATA (SATA)

Tray loss protection: Yes

Secure: No

Preferred owner: Controller in slot A

Current owner: Controller in slot A

Segment size: 128 KB

Capacity reserved for future segment size changes: Yes

Maximum future segment size: 2,048 KB

Modification priority: High

Read cache: Enabled

Write cache: Enabled

Write cache without batteries: Disabled

Write cache with mirroring: Enabled

Flush write cache after (in seconds): 10.00

Dynamic cache read prefetch: Enabled

Enable background media scan: Disabled

Media scan with redundancy check: Disabled

Pre-Read redundancy check: Disabled

Volume name: 2

Volume status: Optimal

Capacity: 1.000 GB

Volume world-wide identifier: 60:0a:0b:80:00:29:ed:12:00:00

Subsystem ID (SSID): 15

Associated volume group: Volume-Group-2

RAID level: 1

LUN: 14

Accessible By: Default Group

Media type: Hard Disk Drive

Interface type: Fibre Channel

Tray loss protection: Yes

Secure: No

Preferred owner: Controller in slot B

Current owner: Controller in slot B

Segment size: 128 KB

Capacity reserved for future segment size changes: Yes

Maximum future segment size: 2,048 KB

Modification priority: High

Read cache: Enabled

Write cache: Enabled

```

    Write cache without batteries:      Disabled
    Write cache with mirroring:         Enabled
    Flush write cache after (in seconds): 10.00
    Dynamic cache read prefetch:        Enabled
    Enable background media scan:       Disabled
    Media scan with redundancy check:    Disabled
    Pre-Read redundancy check:          Disabled
Volume name:                           3
Volume status:                          Optimal
Capacity:                               10.000 GB
Volume world-wide identifier:           60:0a:0b:80:00:29:ed:12:00:00
Subsystem ID (SSID):                    16
Associated volume group:                 Volume-Group-2
RAID level:                             1
LUN:                                    15
Accessible By:                          Default Group
Media type:                             Hard Disk Drive
Interface type:                         Fibre Channel
Tray loss protection:                   Yes
Secure:                                 No
Preferred owner:                        Controller in slot A
Current owner:                          Controller in slot A
Segment size:                           128 KB
Capacity reserved for future segment size changes: Yes
Maximum future segment size:            2,048 KB
Modification priority:                   High
Read cache:                             Enabled
Write cache:                             Enabled
    Write cache without batteries:      Disabled
    Write cache with mirroring:         Enabled
    Flush write cache after (in seconds): 10.00
    Dynamic cache read prefetch:        Enabled
    Enable background media scan:       Disabled
    Media scan with redundancy check:    Disabled
    Pre-Read redundancy check:          Disabled
Volume name:                           4
Volume status:                          Optimal
Capacity:                               3.000 GB
Volume world-wide identifier:           60:0a:0b:80:00:29:ed:12:00:00
Subsystem ID (SSID):                    17
Associated volume group:                 Volume-Group-2
RAID level:                             1
LUN:                                    16
Accessible By:                          Default Group
Media type:                             Hard Disk Drive
Interface type:                         Fibre Channel
Tray loss protection:                   Yes
Secure:                                 No
Preferred owner:                        Controller in slot B
Current owner:                          Controller in slot B
Segment size:                           128 KB
Capacity reserved for future segment size changes: Yes
Maximum future segment size:            2,048 KB
Modification priority:                   High
Read cache:                             Enabled
Write cache:                             Enabled

```

```

    Write cache without batteries:      Disabled
    Write cache with mirroring:         Enabled
    Flush write cache after (in seconds): 10.00
    Dynamic cache read prefetch:        Enabled
    Enable background media scan:       Disabled
    Media scan with redundancy check:    Disabled
    Pre-Read redundancy check:          Disabled
Volume name:                           Unamed
Volume status:                          Optimal
Capacity:                               100.004 GB
Volume world-wide identifier:           60:0a:0b:80:00:29:ed:12:00:00
Subsystem ID (SSID):                    0
Associated volume group:                 Volume-Group-1
RAID level:                             0
LUN:                                     0
Accessible By:                          Default Group
Media type:                              Hard Disk Drive
Interface type:                         Serial ATA (SATA)
Tray loss protection:                   No
Secure:                                  No
Preferred owner:                        Controller in slot B
Current owner:                          Controller in slot B
Segment size:                           16 KB
Capacity reserved for future segment size changes: Yes
Maximum future segment size:            Not Appl
Modification priority:                  Low
Read cache:                             Enabled
Write cache:                             Disabled
    Write cache without batteries:      Disabled
    Write cache with mirroring:         Disabled
    Flush write cache after (in seconds): 10.00
    Dynamic cache read prefetch:        Disabled
    Enable background media scan:       Enabled
    Media scan with redundancy check:    Enabled

```

SNAPSHOT REPOSITORY VOLUMES-----

SUMMARY

```

Number of snapshot repositories: 1
NAME    CAPACITY USAGE(%) THRESHOLD WARNING FULL POLICY
DAE1-1  0                50% full          Fail snapshot

```

DETAILS

```

SNAPSHOT REPOSITORY VOLUME NAME: DAE1-1
Snapshot repository volume status: Optimal
Capacity usage (%):                0
Notify when capacity reaches:       50% full
Snapshot repository full policy:     Fail snapshot volume
Associated base volume (standard):   Unnamed
Associated snapshot volume:          DAE1
Volume name:                        DAE1-1
    Volume status:                   Optimal
    Capacity:                        20.000 MB
    Volume world-wide identifier:     60:0a:0b:80:00:29:ed:12
    Subsystem ID (SSID):              11
    RAID level:                       0
    Media type:                       Hard Disk Drive
    Interface type:                   Serial ATA (SATA)

```

Tray loss protection: No
 Secure: No
 Preferred owner: Controller in slot B
 Current owner: Controller in slot B
 Segment size: 64 KB
 Capacity reserved for future segment size changes: No
 Maximum future segment size: Not ap
 Modification priority: High
 Read cache: Enabled
 Write cache: Enabled
 Write cache without batteries: Disabled
 Write cache with mirroring: Enabled
 Flush write cache after (in seconds): 10.00
 Dynamic cache read prefetch: Disabled
 Enable background media scan: Disabled
 Media scan with redundancy check: Disabled

MIRROR REPOSITORY VOLUMES-----
SUMMARY

Number of mirror repositories: 2

| NAME | STATUS | CAPACITY | RAID LEVEL | VOLUME |
|---------------------|---------|------------|------------|--------|
| Mirror Repository 2 | Optimal | 129.093 MB | 10 | 6 |
| Mirror Repository 1 | Optimal | 129.093 MB | 10 | 6 |

DETAILS

MIRROR REPOSITORY VOLUME NAME: Mirror Repository 2
 Mirror repository volume status: Optimal
 Volume name: Mirror Repository 2
 Volume status: Optimal
 Capacity: 129.093 MB
 Volume world-wide identifier: 60:0a:0b:80:00:29:ed
 Subsystem ID (SSID): 12
 Associated volume group: 6
 RAID level: 10
 Media type: Hard Disk Drive
 Interface type: Serial ATA (SATA)
 Tray loss protection: Yes
 Secure: No
 Preferred owner: Controller in slot B
 Current owner: Controller in slot B
 Segment size: 32 KB
 Capacity reserved for future segment size changes: No
 Maximum future segment size: Not applicable
 Modification priority: High

MIRROR REPOSITORY VOLUME NAME: Mirror Repository 1
 Mirror repository volume status: Optimal
 Volume name: Mirror Repository 1
 Volume status: Optimal
 Capacity: 129.093 MB
 Volume world-wide identifier: 60:0a:0b:80:00:29:ed
 Subsystem ID (SSID): 13
 Associated volume group: 6
 RAID level: 10
 Media type: Hard Disk Drive
 Interface type: Serial ATA (SATA)
 Tray loss protection: Yes
 Secure: No

Preferred owner: Controller in slot A
 Current owner: Controller in slot A
 Segment size: 32 KB
 Capacity reserved for future segment size changes: No
 Maximum future segment size: Not applicable
 Modification priority: High

SNAPSHOT VOLUMES-----

SUMMARY

Number of snapshot volumes: 1

| NAME | STATUS | CREATION | TIMESTAMP |
|------|---------|----------|-----------|
| DAE1 | Optimal | 9/24/10 | 8:54 AM |

DETAILS

SNAPSHOT VOLUME NAME: DAE1

Snapshot status: Optimal
 Creation timestamp: 9/24/10 8:54 AM
 Associated base volume (standard): Unnamed
 Associated snapshot repository volume: DAE1-1
 Volume world-wide identifier: 60:0a:0b:80:00:29:ed:12:00
 Capacity: 100.004 MB
 Preferred owner: Controller in slot B
 Current owner: Controller in slot B

COPIES-----

SUMMARY

Number of copies: 10

S = Source volume

T = Target volume

| COPY PAIR | STATUS | COMPLETION | TIMESTAMP |
|---------------------|-----------|------------|-------------|
| 5 (S), 10 (T) | Completed | 10/14/10 | 3:16:27 PM |
| 5 (S), 8 (T) | Completed | 10/18/10 | 9:46:45 AM |
| 10 (S), 9 (T) | Stopped | None | |
| (S), 7 (T) | Completed | 10/14/10 | 3:13:37 PM |
| 5 (S), 4 (T) | Completed | 10/14/10 | 3:18:23 PM |
| 1 (S), 3 (T) | Completed | 10/14/10 | 3:22:56 PM |
| Unnamed (S), 5 (T) | Completed | 9/16/10 | 2:30:06 PM |
| Unnamed (S), 11 (T) | Stopped | None | |
| Unnamed (S), 6 (T) | Completed | 9/2/10 | 10:03:56 AM |
| Unnamed (S), 1 (T) | Completed | 9/16/10 | 12:41:14 PM |

DETAILS

Copy pair: Unnamed and 4

Copy status: Copy pair: Unnamed and 4
 Copy status: Completed
 Start timestamp: 9/16/10 2:29:23 PM
 Completion timestamp: 9/16/10 2:30:06 PM
 Copy priority: Lowest
 Source volume: Unnamed
 Volume world-wide identifier: 60:0a:0b:80:00:29:ed:12
 Target volume: 5
 Volume world-wide identifier: 60:0a:0b:80:00:47:5b:8a
 Read-only: Disabled

Copy pair: Unnamed and 3

Copy status: Stopped
 Start timestamp: None
 Completion timestamp: None
 Copy priority: Lowest

```

Source volume: Unnamed
  Volume world-wide identifier: 60:0a:0b:80:00:29:ed:12
Target volume: 11
  Volume world-wide identifier: 60:0a:0b:80:00:29:ed:12
  Read-only: Enabled
Copy pair: Unnamed and 2
Copy status: Completed
Start timestamp: 9/2/10 10:03:41 AM
Completion timestamp: 9/2/10 10:03:56 AM
Copy priority: Medium
Source volume: Unnamed
  Volume world-wide identifier: 60:0a:0b:80:00:29:ed:12
Target volume: 6
  Volume world-wide identifier: 60:0a:0b:80:00:29:ed:12
  Read-only: Enabled
Copy pair: Unnamed and 1
Copy status: Completed
Start timestamp: 9/16/10 12:40:58 PM
Completion timestamp: 9/16/10 12:41:14 PM
Copy priority: Medium
Source volume: Unnamed
  Volume world-wide identifier: 60:0a:0b:80:00:29:ed:1
Target volume: 1
  Volume world-wide identifier: 60:0a:0b:80:00:47:5b:8
  Read-only: Enabled

```

MIRRORED PAIRS-----

Number of mirrored pairs: 0 of 64 used

MISSING VOLUMES-----

Number of missing volumes: 0

Show Drive Channel Stat

The **show drive channel stat** command returns information about the drive channels in a storage array. Use this information to determine how well the channels are running and errors that might be occurring on the channels.

DRIVE CHANNELS-----

SUMMARY

| CHANNEL | PORT | STATUS |
|---------|--|---------|
| 1 | 8,7,ESM A 1A,ESM A 1B,ESM A 1A,ESM A 1B,ESM A 1B | Optimal |
| 2 | 6,5 | Optimal |
| 3 | 4,3 | Optimal |
| 4 | 2,1 | Optimal |
| 5 | 1,2,ESM B 1B,ESM B 1A,ESM B 1B,ESM B 1A,ESM B 1B | Optimal |
| 6 | 3,4 | Optimal |
| 7 | 5,6 | Optimal |
| 8 | 7,8 | Optimal |

DETAILS

DRIVE CHANNEL 1

```

Port: 8, 7, ESM A 1A, ESM A 1B, ESM A 1A, ESM A 1B, ESM A 1B
Status: Optimal

```

Max. Rate: 4 Gbps
Current Rate: 4 Gbps
Rate Control: Auto
Controller A link status: Up
Controller B link status: Up
Trunking active: No

DRIVE COUNTS

Total # of attached drives: 44
Connected to: Controller A, Port 8
Attached drives: 44
Drive tray: 3 (14 drives)
Drive tray: 1 (15 drives)
Drive tray: 2 (15 drives)

CUMULATIVE ERROR COUNTS

Controller A

Baseline time set: 10/30/10 1:15:59 PM
Sample period (days, hh:mm:ss): 32 days, 00:55:04
Controller detected errors: 0
Drive detected errors: 48
Timeout errors: 1
Link down errors: N/A
Total I/O count: 199070838

Controller B

Baseline time set: 10/30/10 1:15:59 PM
Sample period (days, hh:mm:ss): 32 days, 00:53:22
Controller detected errors: 0
Drive detected errors: 52
Timeout errors: 0
Link down errors: N/A
Total I/O count: 198778804

DRIVE CHANNEL 2

Port: 6, 5
Status: Optimal
Max. Rate: 4 Gbps
Current Rate: 4 Gbps
Rate Control: Auto
Controller A link status: Up
Controller B link status: Up
Trunking active: No

DRIVE COUNTS

Total # of attached drives: 0

CUMULATIVE ERROR COUNTS

Controller A

Baseline time set: 10/30/10 1:15:59 PM
Sample period (days, hh:mm:ss): 32 days, 00:55:04
Controller detected errors: 0
Drive detected errors: 0
Timeout errors: 2
Link down errors: N/A
Total I/O count: 14238433

Controller B

```

Baseline time set:          10/30/10 1:15:59 PM
Sample period (days, hh:mm:ss): 32 days, 00:53:22
Controller detected errors: 0
Drive detected errors:      0
Timeout errors:            0
Link down errors:          N/A
Total I/O count:           13470436

```

DRIVE CHANNEL 3

```

Port: 6, 5
Status: Optimal
Max. Rate: 4 Gbps
Current Rate: 4 Gbps
Rate Control: Auto
Controller A link status: Up
Controller B link status: Up
Trunking active: No

```

DRIVE COUNTS

Total # of attached drives: 0

CUMULATIVE ERROR COUNTS

Controller A

```

Baseline time set:          10/30/10 1:15:59 PM
Sample period (days, hh:mm:ss): 32 days, 00:55:04
Controller detected errors: 0
Drive detected errors:      0
Timeout errors:            0
Link down errors:          N/A
Total I/O count:           13414513

```

Controller B

```

Baseline time set:          10/30/10 1:15:59 PM
Sample period (days, hh:mm:ss): 32 days, 00:53:22
Controller detected errors: 0
Drive detected errors:      0
Timeout errors:            0
Link down errors:          N/A
Total I/O count:           13201515

```

DRIVE CHANNEL 4

```

Port: 2, 1
Status: Optimal
Max. Rate: 4 Gbps
Current Rate: 2 Gbps
Rate Control: Auto
Controller A link status: Up
Controller B link status: Up
Trunking active: No

```

DRIVE COUNTS

Total # of attached drives: 0

CUMULATIVE ERROR COUNTS

Controller A

```

Baseline time set:          10/30/10 1:15:59 PM
Sample period (days, hh:mm:ss): 32 days, 00:55:04
Controller detected errors: 111

```

Drive detected errors: 0
 Timeout errors: 0
 Link down errors: N/A
 Total I/O count: 13093814

Controller B

Baseline time set: 10/30/10 1:15:59 PM
 Sample period (days, hh:mm:ss): 32 days, 00:53:22
 Controller detected errors: 54
 Drive detected errors: 0
 Timeout errors: 0
 Link down errors: N/A
 Total I/O count: 13039285

DRIVE CHANNEL 5

Port: 1, 2, ESM B 1B, ESM B 1A, ESM B 1B, ESM B 1A, ESM B 1B
 Status: Optimal
 Max. Rate: 4 Gbps
 Current Rate: 4 Gbps
 Rate Control: Auto
 Controller A link status: Up
 Controller B link status: Up
 Trunking active: No

DRIVE COUNTS

Total # of attached drives: 44
 Connected to: Controller B, Port 1
 Attached drives: 44
 Drive tray: 3 (14 drives)
 Drive tray: 1 (15 drives)
 Drive tray: 2 (15 drives)

CUMULATIVE ERROR COUNTS

Controller A

Baseline time set: 10/30/10 1:15:59 PM
 Sample period (days, hh:mm:ss): 32 days, 00:55:04
 Controller detected errors: 0
 Drive detected errors: 49
 Timeout errors: 1
 Link down errors: N/A
 Total I/O count: 183366503

Controller B

Baseline time set: 10/30/10 1:15:59 PM
 Sample period (days, hh:mm:ss): 32 days, 00:53:22
 Controller detected errors: 1
 Drive detected errors: 52
 Timeout errors: 0
 Link down errors: N/A
 Total I/O count: 182512319

DRIVE CHANNEL 6

Port: 3, 4
 Status: Optimal
 Max. Rate: 4 Gbps
 Current Rate: 2 Gbps
 Rate Control: Auto
 Controller A link status: Up

Controller B link status: Up
Trunking active: No

DRIVE COUNTS

Total # of attached drives: 0

CUMULATIVE ERROR COUNTS

Controller A

| | |
|---------------------------------|---------------------|
| Baseline time set: | 10/30/10 1:15:59 PM |
| Sample period (days, hh:mm:ss): | 32 days, 00:55:04 |
| Controller detected errors: | 0 |
| Drive detected errors: | 0 |
| Timeout errors: | 0 |
| Link down errors: | 0 |
| Total I/O count: | 13296480 |

Controller B

| | |
|---------------------------------|---------------------|
| Baseline time set: | 10/30/10 1:15:59 PM |
| Sample period (days, hh:mm:ss): | 32 days, 00:53:22 |
| Controller detected errors: | 0 |
| Drive detected errors: | 0 |
| Timeout errors: | 0 |
| Link down errors: | N/A |
| Total I/O count: | 13275865 |

DRIVE CHANNEL 7

Port: 5, 6
Status: Optimal
Max. Rate: 4 Gbps
Current Rate: 2 Gbps
Rate Control: Auto
Controller A link status: Up
Controller B link status: Up
Trunking active: No

DRIVE COUNTS

Total # of attached drives: 0

CUMULATIVE ERROR COUNTS

Controller A

| | |
|---------------------------------|---------------------|
| Baseline time set: | 10/30/10 1:15:59 PM |
| Sample period (days, hh:mm:ss): | 32 days, 00:55:04 |
| Controller detected errors: | 0 |
| Drive detected errors: | 0 |
| Timeout errors: | 0 |
| Link down errors: | 0 |
| Total I/O count: | 131818784 |

Controller B

| | |
|---------------------------------|---------------------|
| Baseline time set: | 10/30/10 1:15:59 PM |
| Sample period (days, hh:mm:ss): | 32 days, 00:53:22 |
| Controller detected errors: | 0 |
| Drive detected errors: | 0 |
| Timeout errors: | 0 |
| Link down errors: | N/A |
| Total I/O count: | 13171844 |

DRIVE CHANNEL 8

```
Port: 7, 8
Status: Optimal
Max. Rate: 4 Gbps
Current Rate: 4 Gbps
Rate Control: Auto
Controller A link status: Up
Controller B link status: Up
Trunking active: No
```

DRIVE COUNTS

```
Total # of attached drives: 0
```

CUMULATIVE ERROR COUNTS

Controller A

```
Baseline time set:          10/30/10 1:15:59 PM
Sample period (days, hh:mm:ss): 32 days, 00:55:04
Controller detected errors:  44
Drive detected errors:      0
Timeout errors:             0
Link down errors:           0
Total I/O count:            13067464
```

Controller B

```
Baseline time set:          10/30/10 1:15:59 PM
Sample period (days, hh:mm:ss): 32 days, 00:53:22
Controller detected errors:  25
Drive detected errors:      0
Timeout errors:             0
Link down errors:           N/A
Total I/O count:            12987004
```

Show Drive

The **show drive** command returns information about the drives in a storage array.

DRIVES-----

SUMMARY

Number of drives: 14
Supported drive types: Fibre (14)

BASIC:

| TRAY, SLOT | STATUS | CAPACITY | CURRENT DATA RATE | PRODUCT ID | FIRMWARE VERSION |
|------------|---------|-----------|-------------------|------------|------------------|
| 1, 1 | Optimal | 68.366 GB | 2 Gbps | ST373453FC | MS03 |
| 1, 2 | Optimal | 68.366 GB | 2 Gbps | ST373453FC | MS03 |
| 1, 3 | Optimal | 68.366 GB | 2 Gbps | ST373453FC | MS03 |
| 1, 4 | Optimal | 68.366 GB | 2 Gbps | ST373453FC | MS03 |
| 1, 5 | Optimal | 68.366 GB | 2 Gbps | ST373453FC | MS03 |
| 1, 6 | Optimal | 68.366 GB | 2 Gbps | ST373453FC | MS03 |
| 1, 7 | Optimal | 68.366 GB | 2 Gbps | ST373453FC | MS03 |
| 1, 8 | Optimal | 68.366 GB | 2 Gbps | ST373453FC | MS03 |
| 1, 9 | Optimal | 68.366 GB | 2 Gbps | ST373453FC | MS03 |
| 1, 10 | Optimal | 68.366 GB | 2 Gbps | ST373453FC | MS03 |
| 1, 11 | Optimal | 68.366 GB | 2 Gbps | ST373453FC | MS03 |
| 1, 12 | Optimal | 68.366 GB | 2 Gbps | ST373453FC | MS03 |
| 1, 13 | Optimal | 68.366 GB | 2 Gbps | ST373453FC | MS03 |
| 1, 14 | Optimal | 68.366 GB | 2 Gbps | ST373453FC | MS03 |

DRIVE CHANNELS:

| TRAY, SLOT | PREFERRED CHANNEL | REDUNDANT CHANNEL |
|------------|-------------------|-----------------------------|
| 1, 1 | 3 | Drive path redundancy: Lost |
| 1, 2 | 3 | Drive path redundancy: Lost |
| 1, 3 | 3 | Drive path redundancy: Lost |
| 1, 4 | 3 | Drive path redundancy: Lost |
| 1, 5 | 3 | Drive path redundancy: Lost |
| 1, 6 | 3 | Drive path redundancy: Lost |
| 1, 7 | 3 | Drive path redundancy: Lost |
| 1, 8 | 3 | Drive path redundancy: Lost |
| 1, 9 | 3 | Drive path redundancy: Lost |
| 1, 10 | 3 | Drive path redundancy: Lost |
| 1, 11 | 3 | Drive path redundancy: Lost |
| 1, 12 | 3 | Drive path redundancy: Lost |
| 1, 13 | 3 | Drive path redundancy: Lost |
| 1, 14 | 3 | Drive path redundancy: Lost |

HOT SPARE COVERAGE:

The following volume groups are not protected: 3

Total hot spare drives: 2
Standby: 2
In use: 0

Standby drive at tray 1, slot 8 (Fibre, 68.366 GB)
Protects the following volume groups: 2, 1

DETAILS

Drive at Tray 1, Slot 1
Drive port: 1, Channel: 3, ID: 8/0xD9
Drive path redundancy: Lost
Status: Optimal
Raw capacity: 68.366 GB
Usable capacity: 67.866 GB
Current data rate: 2 Gbps
Product ID: ST373453FC
Firmware version: MS03
Serial number: 3HW0535L00007329LFD8
Vendor: SEAGATE
Date of manufacture: January 20, 2003
World-wide name: 20:00:00:04:cf:0b:c6:0d
Drive type: Fibre Channel
Speed: 15015 RPM
Mode: Assigned
Associated volume group: Volume group 2

Drive at Tray 1, Slot 2
Drive port: 1, Channel: 3, ID: 9/0xD6
Drive path redundancy: Lost
Status: Optimal
Raw capacity: 68.366 GB
Usable capacity: 67.866 GB
Current data rate: 2 Gbps
Product ID: ST373453FC
Firmware version: MS03
Serial number: 3HW056D500007329VVAP
Vendor: SEAGATE
Date of manufacture: January 23, 2003
World-wide name: 20:00:00:04:cf:0b:dc:29
Drive type: Fibre Channel
Speed: 15015 RPM
Mode: Assigned
Associated volume group: Volume group 2

Drive at Tray 1, Slot 3
Drive port: 1, Channel: 3, ID: 10/0xD5
Drive path redundancy: Lost
Status: Optimal
Raw capacity: 68.366 GB
Usable capacity: 67.866 GB
Current data rate: 2 Gbps
Product ID: ST373453FC
Firmware version: MS03
Serial number: 3HW04LMK00007329DYZK
Vendor: SEAGATE
Date of manufacture: January 17, 2003
World-wide name: 20:00:00:04:cf:0b:b1:f6
Drive type: Fibre Channel
Speed: 15015 RPM
Mode: Unassigned
Associated volume group: Volume group None

Drive at Tray 1, slot 4
Drive port: 1, Channel: 3, ID: 11/0xD4
Drive path redundancy: Lost
Status: Optimal
Raw capacity: 68.366 GB
Usable capacity: 67.866 GB
Current data rate: 2 Gbps
Product ID: ST373453FC
Firmware version: MS03
Serial number: 3HW04N2T00007329DZGZ
Vendor: SEAGATE
Date of manufacture: January 17, 2003
World-wide name: 20:00:00:04:cf:0b:b1:81
Drive type: Fibre Channel
Speed: 15015 RPM
Mode: Assigned
Associated volume group: Volume group 3

Drive at Tray 1, slot 5
Drive port: 1, Channel: 3, ID: 12/0xD3
Drive path redundancy: Lost
Status: Optimal
Raw capacity: 68.366 GB
Usable capacity: 67.866 GB
Current data rate: 2 Gbps
Product ID: ST373453FC
Firmware version: MS03
Serial number: 3HW04YN500007329JQYG
Vendor: SEAGATE
Date of manufacture: January 23, 2003
World-wide name: 20:00:00:04:cf:0b:db:2c
Drive type: Fibre Channel
Speed: 15015 RPM
Mode: Unassigned
Associated volume group: Volume group None

Drive at Tray 1, slot 6
Drive port: 1, Channel: 3, ID: 13/0xD2
Drive path redundancy: Lost
Status: Optimal
Raw capacity: 68.366 GB
Usable capacity: 67.866 GB
Current data rate: 2 Gbps
Product ID: ST373453FC
Firmware version: MS03
Serial number: 3HW056N300007328ZC57
Vendor: SEAGATE
Date of manufacture: January 23, 2003
World-wide name: 20:00:00:04:cf:0b:db:66
Drive type: Fibre Channel
Speed: 15015 RPM
Mode: Assigned
Associated volume group: Volume group 2

Drive at Tray 1, Slot 7
Drive port: 1, Channel: 3, ID: 14/0xD1
Drive path redundancy: Lost
Status: Optimal
Raw capacity: 68.366 GB
Usable capacity: 67.866 GB
Current data rate: 2 Gbps
Product ID: ST373453FC
Firmware version: MS03
Serial number: 3HW04XKQ00007329VUR8
Vendor: SEAGATE
Date of manufacture: January 23, 2003
World-wide name: 20:00:00:04:cf:0b:db:a1
Drive type: Fibre Channel
Speed: 15015 RPM
Mode: Assigned
Associated volume group: volume group 2

Drive at Tray 1, Slot 8
Drive port: 1, Channel: 3, ID: 15/0xCE
Drive path redundancy: Lost
Status: Optimal
Raw capacity: 68.366 GB
Usable capacity: 67.866 GB
Current data rate: 2 Gbps
Product ID: ST373453FC
Firmware version: MS03
Serial number: 3HW04QL300007328H6BU
Vendor: SEAGATE
Date of manufacture: January 23, 2003
World-wide name: 20:00:00:04:cf:0b:db:6f
Drive type: Fibre Channel
Speed: 15015 RPM
Mode: Hot spare standby
Associated volume group: volume group None

Drive at Tray 1, Slot 9
Drive port: 1, Channel: 3, ID: 81/0x54
Drive path redundancy: Lost
Status: Optimal
Raw capacity: 68.366 GB
Usable capacity: 67.866 GB
Current data rate: 2 Gbps
Product ID: ST373453FC
Firmware version: MS03
Serial number: 3HW04WSE00007329EQX2
Vendor: SEAGATE
Date of manufacture: January 18, 2003
World-wide name: 20:00:00:04:cf:0b:b2:5b
Drive type: Fibre Channel
Speed: 15015 RPM
Mode: Unassigned
Associated volume group: volume group None

Drive at Tray 1, Slot 10
Drive port: 1, Channel: 3, ID: 97/0x39
Drive path redundancy: Lost
Status: Optimal
Raw capacity: 68.366 GB
Usable capacity: 67.866 GB
Current data rate: 2 Gbps
Product ID: ST373453FC
Firmware version: MS03
Serial number: 3HW04V5P00007329DZPH
Vendor: SEAGATE
Date of manufacture: January 17, 2003
World-wide name: 20:00:00:04:cf:0b:b1:97
Drive type: Fibre Channel
Speed: 15015 RPM
Mode: Assigned
Associated volume group: Volume group 2

Drive at Tray 1, Slot 11
Drive port: 1, Channel: 3, ID: 65/0x71
Drive path redundancy: Lost
Status: Optimal
Raw capacity: 68.366 GB
Usable capacity: 67.866 GB
Current data rate: 2 Gbps
Product ID: ST373453FC
Firmware version: MS03
Serial number: 3HW056N700007329T7EG
Vendor: SEAGATE
Date of manufacture: January 23, 2003
World-wide name: 20:00:00:04:cf:0b:db:69
Drive type: Fibre Channel
Speed: 15015 RPM
Mode: Assigned
Associated volume group: Volume group 2

Drive at Tray 1, Slot 12
Drive port: 1, Channel: 3, ID: 73/0x66
Drive path redundancy: Lost
Status: Optimal
Raw capacity: 68.366 GB
Usable capacity: 67.866 GB
Current data rate: 2 Gbps
Product ID: ST373453FC
Firmware version: MS03
Serial number: 3HW04DL400007329ERF1
Vendor: SEAGATE
Date of manufacture: January 17, 2003
World-wide name: 20:00:00:04:cf:0b:b1:84
Drive type: Fibre Channel
Speed: 15015 RPM
Mode: Assigned
Associated volume group: Volume group 1

Drive at Tray 1, Slot 13
Drive port: 1, Channel: 3, ID: 89/0x4A
Drive path redundancy: Lost
Status: Optimal
Raw capacity: 68.366 GB
Usable capacity: 67.866 GB
Current data rate: 2 Gbps
Product ID: ST373453FC
Firmware version: MS03
Serial number: 3HW04DJT00007329DZJF
Vendor: SEAGATE
Date of manufacture: January 18, 2003
World-wide name: 20:00:00:04:cf:0b:b0:ff
Drive type: Fibre Channel
Speed: 15015 RPM
Mode: Assigned
Associated volume group: Volume group 1

Drive at Tray 1, Slot 14
Drive port: 1, Channel: 3, ID: 105/0x2D
Drive path redundancy: Lost
Status: Optimal
Raw capacity: 68.366 GB
Usable capacity: 67.866 GB
Current data rate: 2 Gbps
Product ID: ST373453FC
Firmware version: MS03
Serial number: 3HW04VAK00007329ER3P
Vendor: SEAGATE
Date of manufacture: January 17, 2003
World-wide name: 20:00:00:04:cf:0b:b1:6e
Drive type: Fibre Channel
Speed: 15015 RPM
Mode: Assigned
Associated volume group: Volume group 1

Example Script Files

This appendix provides example scripts for configuring a storage array. These examples show how the script commands appear in a complete script file. Also, you can copy these scripts and modify them to create a configuration unique to your storage array.

You can create a script file in two ways:

- Using the `save storageArray configuration` command
- Writing a script

By using the `save storageArray configuration` command, you can create a file that you can use to copy an existing configuration from one storage array to other storage arrays. You can also use this file to restore an existing configuration that has become corrupted. You also can copy an existing file to serve as a pattern from which you create a new script file by modifying portions of the original file. The default file extension is `.scr`.

You can create a new script file by using a text editor, such as Microsoft Notepad. The maximum line length is 256 characters. The command syntax must conform to the guidelines in the topic "[About the Command Line Interface](#)" and the topic "[About the Script Commands](#)". When you create a new script file, you can use any file name and extension that will run on the host operating system.

This example shows how to run a script file from the command line.

```
c:\...\smX\client>smcli 123.45.67.88 123.45.67.89
-f scriptfile.scr;
```

Configuration Script Example 1

This example creates a new volume by using the `create volume` command in the free space of a volume group.

```
Show "Create RAID 5 Volume 7 on existing Volume Group 1";

//Create volume on volume group created by the create
volume drives command

//Note: For volume groups that use all available
capacity, the last volume on the group is created using
all remaining capacity by omitting the capacity=volume
creation parameter

create volume volumeGroup=1 RAIDLevel=5 userLabel="7"
owner=A segmentSize=16 cacheReadPrefetch=TRUE capacity=2GB;

show "Setting additional attributes for volume 7";
//Configuration settings that cannot be set during volume
creation
set volume["7"] cacheFlushModifier=10;
set volume["7"] cacheWithoutBatteryEnabled=false;
set volume["7"] mirrorEnabled=true;
set volume["7"] readCacheEnabled=true;
set volume["7"] writeCacheEnabled=true;
set volume["7"] mediaScanEnabled=false;
```

```
set volume["7"] redundancyCheckEnabled=false;
set volume["7"] modificationPriority=high;
```

This example shows blank lines between the lines beginning with `Show`, `Create`, `//Note`, and `create`. The blank lines are included in this example only for clarity. Each command is actually written on one line in the script file; however, the size of this page has caused the command text to wrap. You might want to include blank lines in your script files to separate blocks of commands or make a comment that stands out. To include a comment, enter two forward slashes (`//`), which causes the Script Engine to treat the line as a comment.

The first line of text is the `show string` command. This command shows text that is bounded by double quotation marks (" ") on a display monitor when the script file runs. In this example, the text `Create RAID 5 Volume 7 on existing Volume Group 1` serves as a title that describes the expected results of running this script file.

The line beginning with `//Create` is a comment that explains that the purpose of this script file is to create a new volume by using the `create volume` command on an existing volume group.

The line beginning `//Note:` is a comment in the script file that explains that the size of the last volume created that uses all of the available capacity because the `capacity` parameter is not used.

The command in this example creates a new volume in volume group 1. The volume has RAID Level 5. The volume name (user label) is 7. (Note the double quotation marks around the 7. The double quotation marks define that the information in the double quotation marks is a label.) The new volume is assigned to the controller in slot A in the controller tray. The segment size is set to 16. The volume has a read ahead multiplier value of 256. The capacity of the volume is 2 GB.

The command takes this form:

```
create volume volumeGroup=volumeGroupName
userLabel=volumeName
[freeCapacityArea=freeCapacityIndexNumber]
[capacity=volumeCapacity | owner=(a | b) |
cacheReadPrefetch=(TRUE | FALSE) |
segmentSize=segmentSizeValue]
[trayLossProtect=(TRUE | FALSE)]
```

The general form of the command shows the optional parameters in a different sequence than the optional parameters in the example command. You can enter optional parameters in any sequence. You must enter the required parameters in the sequence shown in the command descriptions.

The line showing "Setting additional attributes for volume 7" is another example of using the `show "string"` command. The reason for placing this command here is to tell the user that the `create volume` command ran successfully and that properties that could not be set by the `create volume` command are now set.

The `set volume` parameters are shown on separate lines. You do not need to use separate lines for each parameter. You can enter more than one parameter with the `set volume` command by leaving a space between the parameters, as in this example:

```
set volume["7"] cacheFlushModifier=10
cacheWithoutBatteryEnabled=false
modificationPriority=high;
```

By using separate lines, you can see more clearly the parameters that you are setting and the values to which you are setting the parameters. Blocking the parameters in this manner makes it easier to either edit the file or copy specific parameter settings for use in another script file.

Configuration Script Example 2

This example creates a new volume by using the **create volume** command with user-defined drives in the storage array.

```
Show "Create RAID3 Volume 2 on existing Volume Group 2";

//This command creates the volume group and the initial volume on that group.

//Note: For volume groups that use all available capacity, the last volume
on the volume group is created using all remaining capacity by omitting the
capacity=volume creation parameter

create volume RAIDLevel=3 userLabel="2" drives=[0,1 0,6 1,7 1,3 2,3 2,6]
owner=B segmentSize=16 capacity=2GB;

show "Setting additional attributes for volumem 7"
//Configuration settings that cannot be set during volume creation
set volume ["7"] cacheFlushModifier=10;
set volume ["7"] cacheWithoutBatteryEnabled=false;
set volume ["7"] mirrorEnabled=true;
set volume ["7"] readCacheEnabled=true;
set volume ["7"] writeCacheEnabled=true;
set volume ["7"] mediaScanEnabled=false;
set volume ["7"] redundantCheckEnabled=false;
set volume ["7"] modificationPriority=high;
```

The command in this example, like the **create volume** command in the previous example, creates a new volume. The significant difference between these two examples is that this example shows how you can define specific drives to include in the volume. Use the **show storageArray profile** command to find out what drives are available in a storage array.

The **create volume** command takes this form:

```
create volume raidLevel=(0 | 1 | 3 | 5 | 6) userLabel=volumeName
drives=(trayID1,slotID1...trayIDn,slotIDn)
[capacity=volumeCapacity | owner=(a | b) |
cacheReadPrefetch=(TRUE | FALSE) |
segmentSize=segmentSizeValue]
[trayLossProtect=(TRUE | FALSE)]
```

Asynchronous Remote Volume Mirroring Utility

This appendix describes the host utility to achieve periodic consistency with Asynchronous Remote Volume Mirroring configurations. This appendix also describes how to run the Asynchronous Remote Volume Mirroring utility.

Description of the Asynchronous Remote Volume Mirroring Utility

The Asynchronous Remote Volume Mirroring utility lets you periodically synchronize the Remote Volume Mirroring pairs in your storage array. When defining a Remote Volume Mirroring configuration, you have the option to set the write modes to either Synchronous or Asynchronous. Synchronous write mode provides the highest level security for full data recovery from the secondary storage array in the event of a disaster. Synchronous write mode does, however, reduce host I/O performance. Asynchronous write mode offers faster host I/O performance, but it does not guarantee that a copy operation has successfully completed before processing the next write request. With Asynchronous write mode, you cannot make sure that a volume, or collection of volumes, at a secondary site ever reach a consistent, recoverable state.

The Asynchronous Remote Volume Mirroring utility enables you to bring a collection of asynchronous remote volumes into a mutually consistent and recoverable state. You can choose to run the utility based on application demands, link state and speed, and other factors that are relevant to your environment.

The Asynchronous Remote Volume Mirroring utility has these characteristics:

- The utility is implemented as a command line-invoked Java-based application.
- The utility is bundled as part of the SANtricity ES Storage Manager installation package.
- The utility accepts a command line argument that lets you specify the name of a configuration file that contains a complete specification of the work to be carried out by the utility.
- More than one instance of the utility can run concurrently, as long as the utilities do not try to process any of the same volumes and mirrors.



NOTE The Asynchronous Remote Volume Mirroring utility does not check to make sure that concurrently running instances of the utility are not trying to process the same volumes and mirrors. If you choose to simultaneously run more than one instance of the Asynchronous Remote Volume Mirroring utility, you must make sure that the configuration files that you choose to run do not list the same volumes and mirrors.

Operation of the Asynchronous Remote Volume Mirroring Utility

The Asynchronous Remote Volume Mirroring utility performs steps that generate a recoverable state for multiple mirror volumes at a secondary site. The utility runs these steps to create consistent, recoverable images of a set of volumes:

1. **On the primary storage array** – The utility reconfigures all of the participating volumes from asynchronous mirroring to synchronous mirroring. This action makes sure that the stream of write operations becomes recoverable on the secondary side.
2. **On the primary storage array** – The utility polls all of the participating volumes until the associated mirror states all have the Optimal state. In cases where the remote link is slow or the primary host I/O activity is high, one or more mirrors are likely to be in the Unsynchronized state before they transition to the Synchronized state. By waiting until all of the mirrors have Optimal status, the utility makes sure that all of the delta logs for the affected volumes are cleared, and the secondary volumes are recoverable.

3. **On the primary storage array** – The utility suspends the mirrored pairs for all of the participating volumes. This action causes updates to stop on the secondary side, leaving the secondary volumes in a recoverable state because they were being updated in Synchronous mode immediately before the suspension. By separating the mirrors in this manner, the primary-side applications run faster, while leaving the secondary volumes in a recoverable state. The delta log tracks changes made because of application writes on the primary side while in this state.
4. **On the secondary storage array** – The utility generates a snapshot of each participating volume on the secondary side, which creates point-in-time images that are recoverable.
5. **On the primary storage array** – The utility resumes the mirroring operations for all of the participating volumes. This action causes the mirrors to transition to the Synchronized state and start the process of restoring coherency between the primary site and the secondary site.
6. **On the primary storage array** – The utility reconfigures all of the affected volumes for Asynchronous mode.

Running the Asynchronous Remote Volume Mirroring Utility

The Asynchronous Remote Volume Mirroring utility uses a command line argument that lets you specify the name of a configuration file. The configuration file contains a complete specification of the input parameters that are needed by the utility. To run the utility, enter this syntax:

```
asyncRVMUtil configuration_file -d debug_file
```

In this command, *configuration_file* is the file that you provide as input. The configuration file specifies the Remote Volume Mirroring volumes that you want to synchronize by using the utility. When you create the configuration file, use these conditions to define the volumes in the file:

- All the primary volumes in a volume set must belong to the same storage array.
- The maximum number of volume sets that you can specify in the file is four.
- The maximum number of mirrored pairs that you can specify as part of a consistency group is eight.

The optional parameter, *-d*, lets you specify a file to which you can send information regarding how the utility runs. In this example, the file name is *debug_file*. The debug file contains trace information that can be reviewed by your Customer and Technical Support representative to determine how well the Asynchronous Remote Volume Mirroring utility has run.

 **NOTE** Depending on the location of the configuration file and the debug file, you must specify the complete path with the file name.

To run the Asynchronous Remote Volume Mirroring utility, you must enter the `asyncRVMUtil` command from the command line. Because UNIX operating systems are case sensitive, you must type the command exactly as shown. On Windows operating systems, you can type the command in all uppercase, in all lowercase, or in mixed case.

 **NOTE** To use the Asynchronous Remote Volume Mirroring utility, you must be managing the storage array by using the command line interface, not the graphical user interface of SANtricity ES Storage Manager.

Configuration Utility

The configuration file is an ASCII flat text file that provides the information for the Remote Volume Mirroring synchronization used by the Asynchronous Remote Volume Mirroring utility. The file defines the mirror volume sets to be synchronized. All of the mirror volumes in the volume sets defined in the configuration

file are run collectively to create a recoverable image. If any one of the mirrors in the volume set fails, the operation is stopped for this volume set and carried on to the next volume set that is listed in the configuration file.

The configuration file supports this syntax:

```
content ::= {spec}
spec ::= logSpec | volumeSetSpec

logSpec ::= "Log" "{" {logAttribute} "}"
logAttribute ::= fileSpec
fileSpec ::= "file" "=" fileName

volumeSetSpec ::= "VolumeSet" volumeSetName
"{" {volumeSetAttribute} "}"
volumeSetAttribute ::= timeoutSpec | mirrorSpec

timeoutSpec ::= "OptimalWaitTimeLimit" "=" integer

mirrorSpec ::= "Mirror" "{" {mirrorAttribute} "}"
mirrorAttribute ::= primarySpec | secondarySpec |
snapshotSpec

primarySpec ::= "Primary" "=" volumeSpec
secondarySpec ::= "Secondary" "=" volumeSpec
snapshotSpec ::= "Copy" "=" volumeSpec
volumeSpec ::= storageArrayName"."volumeUserLabel
```

In this syntax, items enclosed in double quotation marks (" ") are terminal symbols. Items separated by a vertical bar (|) are alternative values (enter one or the other, but not both). Items enclosed in curly braces ({ }) are optional (you can use the item zero or more times).

These definitions are provided for non-terminals in the syntax:

- *integer* – The timeout value must be an integer (decimal digits from 0–9).
- *volumeSetName* – The name of the set of volumes on which you want to run the Asynchronous Remote Volume Mirroring utility.
- *fileName* – The name of a file, using characters and conventions that are appropriate for the system on which the application is running.
- *storageArrayName* – The label that you have assigned for a storage array, as would be used in the CLI to specify the name of the storage array.
- *volumeUserLabel* – The label that you have assigned for a volume that uniquely identifies the volume within the storage array.



NOTE Names and labels can be any characters that are defined as appropriate for your operating system. The maximum length for a name or label is 30 characters. If the name or label contains special characters (as defined by the operating system) or period characters, you must enclose the name or label in double quotation marks (" "). You can, optionally, enclose the name or label in double quotation marks at any time.

These items are considered syntax errors:

- More than one `logSpec` command in the input file

- Zero or more than one `fileSpec` attribute in a `logSpec` command (you must include exactly one `fileSpec` attribute in the `logSpec` command)
- More than one `timeoutSpec` attribute in a `volumeSetSpec` command
- Zero or more than one `primarySpec` attribute in a `mirrorSpec` command (you must include exactly one `primarySpec` attribute in the `mirrorSpec` command)
- Zero or more than one `secondarySpec` attribute in a `mirrorSpec` command (you must include exactly one `secondarySpec` attribute in the `mirrorSpec` command)
- Zero or more than one `snapshotSpec` attribute in a `mirrorSpec` command (you must include exactly one `snapshotSpec` attribute in the `mirrorSpec` command)

 **IMPORTANT** In the Asynchronous Remote Volume Mirroring utility configuration file, you must specify the primary volume, the secondary volume, and the copy (snapshot) volume. The utility does not make sure that the secondary volume is correct for the Remote Volume Mirroring relationship. The utility also does not make sure that the snapshot volume is actually a snapshot for the secondary volume. *You must make sure that these volumes are correct.* If the volumes are not correct, the utility will run, but the volumes will not be consistent. For each mirror, the secondary volume and the copy volume must reside on the same storage array.

This example shows a configuration file for the Asynchronous Remote Volume Mirroring utility.

```
Log{ file="d:\rvm-consistency.log" }
VolumeSet "set1" {
  optimalWaitTimeLimit = 15
  Mirror {
    Primary = LosAngelesArray.PayrollVolume
    Secondary = NewYorkArray.PayrollVolume
    Copy = NewYorkArray.PayrollVolumeImage
  }
  Mirror {
    Primary = LosAngelesArray.PayrollVolume
    Secondary = BostonArray.PayrollVolume
    Copy = BostonArray.PayrollVolumeImage
  }
}

VolumeSet "set2" {
  Mirror {
    Primary = BostonArray.HRVolume
    Secondary = LosAngelesArray.HRVolume
    Copy = LosAngelesArray.HRVolumeImage
  }
}
```

Simplex-to-Duplex Conversion

Some models of controller trays and controller-drive trays are available in either a simplex configuration (one controller) or a duplex configuration (two controllers). You can convert a simplex configuration to a duplex configuration by installing new nonvolatile static random access memory (NVSRAM) and a second controller. This appendix explains how to convert a simplex configuration to a duplex configuration by using CLI commands or by using the storage management software.

General Steps

You can upgrade a controller tray or a controller-drive tray that has a simplex configuration to a duplex configuration by performing these tasks:

1. Install new NVSRAM on the existing controller in your controller tray or controller-drive tray.
2. Revise the controller tray configuration or the controller-drive tray configuration to run with two controllers.
3. Install a second controller.
4. Connect the host cables.
5. Connect the drive tray cables.
6. Run diagnostics to make sure that your new configuration is running correctly.

Tools and Equipment

The procedures in this appendix require these items:

- Antistatic protection
- A No. 2 Phillips screwdriver
- A second controller
- Small Form-factor Pluggable (SFP) transceivers (for Fibre Channel configurations)
- Host-to-controller cables
- Controller-to-environmental services monitor (ESM) cables

Step 1 – Installing the Duplex NVSRAM



IMPORTANT Before trying to download NVSRAM, you must contact your Customer and Technical Support representative to make sure that you are downloading the NVSRAM that is appropriate for the controller in your storage array.

NVSRAM files specify the default settings for the controller tray controllers or controller-drive tray controllers. Follow the instructions in this step to upgrade the NVSRAM on the controller in your controller tray or your controller-drive tray.

To get a copy of the latest NVSRAM, perform one of these tasks:

- Download the duplex NVSRAM by using the command line interface.
- Download the duplex NVSRAM by using the graphical user interface (GUI) of the storage management software.
- Copy the duplex NVSRAM from the installation CD in the conversion kit.

Make sure that the controller tray or the controller-drive tray has an Optimal status. If one or more managed devices has a Needs Attention status, determine and correct the condition that created the Needs Attention status before proceeding with this conversion instruction.

Downloading the NVSRAM by Using the Command Line Interface

1. Make a copy of your storage array profile, and save it in the event that you might need to restore the storage array.
2. Start the command line interface.
3. On the command line, type this command, and press **Enter**. In this command, *ctlr-A_IP_address* is the IP address of the original simplex controller and *filename* is the complete file path and name of the file that contains the new NVSRAM. Valid file names must end with a `.dlp` extension. Enclose the file name in double quotation marks (" ").

```
smcli ctlr-A_IP_address -c "download storageArray NVSRAM file="filename";"
```

Downloading the NVSRAM by Using the GUI

1. Make a copy of your storage array profile, and save it in the event that you might need to restore the storage array.
2. At the storage management station, start the SMclient software.
3. In the Array Management Window, select **Advanced > Maintenance > Download > Controller NVSRAM**.
4. In the Download NVSRAM dialog, enter the NVSRAM file name in the **Selected NVSRAM** text box. If you do not know the file name, click **Browse**, and navigate to a folder with the NVSRAM files.
5. Select the file that corresponds to your storage array type.
6. Click **OK**.
The **Confirm Download** dialog appears.
7. To start the download, click **Yes**.
8. Based on the dialog that appears after the download has completed, perform one of these actions:
 - **Download Successful dialog** – Click **Done**.
 - **Error dialog** – Read the information in the dialog, and take the appropriate action.

Copying NVSRAM from the Installation CD

1. Make a copy of your storage array profile, and save it in the event that you might need to restore the storage array.
2. Insert the Installation CD into the CD-ROM drive.
3. At the storage management station, start the SMclient software.
4. In the Array Management Window, select **Advanced > Maintenance > Download > Controller NVSRAM**.
5. In the **Download NVSRAM** dialog, select the CD-ROM drive and the `/nvram` folder. Either double-click the folder or type the folder name in the **Selected NVSRAM file** text box.
6. Select the file that corresponds to your storage array type.
7. Click **OK**.
The **Confirm Download** dialog appears.
8. To start the download, click **Yes**.

9. Based on the dialog that appears after the download is completed, perform one of these actions:
 - **Download Successful dialog** – Click **Done**.
 - **Error dialog** – Read the information in the dialog, and take the appropriate action.

Step 2 – Setting the Configuration to Duplex

After rebooting the controller tray or the controller-drive tray, an “alternate controller missing” error message appears. This message indicates that the controller in slot A has successfully converted to Duplex mode. This message persists until you have completed the tasks to install the second controller, installed the host cables, and installed the drive tray cables.

1. Start the command line interface.
2. On the command line, type this command, and press **Enter**. In this command, *ctlr-A_IP_address* is the IP address of the of the original simplex controller.

```
smcli ctlr-A_IP_address -c "set storageArray redundancyMode=duplex;"
```

3. Reboot the controller tray or the controller-drive tray.

Step 3 – Installing the Second Controller

 **ATTENTION Possible hardware damage** – To prevent electrostatic discharge damage to the tray, use proper antistatic protection when handling tray components.

 **IMPORTANT** For best operation, the new controller must have a part number identical to the existing controller, or the new controller must be a certified substitute. The part number is on a label on the controller. To provide full functionality in dual#controller configurations, make sure that both controllers in the controller tray or the controller-drive tray have the same memory capacity. Although you can install two controllers of different memories in a controller tray or a controller-drive tray, the mismatch disables some functions, such as cache mirroring.

1. Put on antistatic protection.

 **ATTENTION Possible damage to the controller** – Do not remove the electrostatic protection until you have finished installing the controller and you have connected the host cables and the drive tray cables.

2. Unpack the new controller.

 **ATTENTION Possible damage to the controller** – Bumping the controller against another surface might damage the data connectors on the rear of the controller. Use caution when handling the controller.

3. Remove the blank controller canister from the tray by releasing the handle, and pulling the blank controller canister out of the tray.
4. Slide the new controller canister into the empty slot by pushing the controller canister until it snaps into place, and locking the handle into the closed position.

Step 4 – Connecting the Host Cables

The steps in this procedure describe how to attach Fibre Channel host cables. The steps for connecting other types of host cables are similar, but they do not require the installation of Small Form-factor Pluggable (SFP) transceivers.

1. If there is a black plastic plug in the host port, remove it.
2. Install an SFP transceiver into the controller by pushing the SFP transceiver into the host port until it snaps into place.



ATTENTION Possible degraded performance – To prevent degraded performance, do not twist, fold, pinch, or step on fiber-optic cables. Do not bend fiber-optic cables tighter than a 5#cm (2-in.) radius.

3. Plug one end of the fiber-optic cable into the SFP transceiver in the host port.
4. Plug the other end of the fiber-optic cable into one of the HBAs in the host (direct topology) or into a switch (switch topology).
5. Attach a label to each end of the cable by using this scheme. A label is very important if you need to disconnect the cables later to service a controller.
 - The host name and the host bus adapter (HBA) port (if direct topology)
 - The switch name and port (if switch topology)
 - The controller ID (for example, controller A)
 - The host channel ID (for example, host channel 1)

Example label abbreviation – Assume that a cable is connected between port 1 in HBA 1 of a host named Engineering and host channel 1 of controller A. A label abbreviation could be as follows:

Heng-ABA1/P1, CtA-Hch1

6. Repeat step 1 through step 5 for each host channel that you intend to use.

Step 5 – Connecting the Controller to a Drive Tray

The steps in this procedure describe how to attach Fibre Channel cables to a drive tray. The steps for connecting other types of drive tray cables are similar, but they do not require the installation of SFP transceivers.

1. If there is a black plastic plug in the drive port of the new controller canister, remove it.
2. Insert an SFP transceiver into the drive port on a controller canister.
3. Plug one end of the cable into the SFP transceiver.
4. Plug the other end of the cable into the appropriate in port or out port on the environmental services monitor (ESM) in the drive tray as applicable for your cabling configuration.
5. Attach a label to each end of the cable by using this scheme. A label is very important if you need to disconnect the cables later to service a controller.
 - The controller ID (for example, controller A)
 - The drive channel number and port ID (for example, drive channel 1, port 2)
 - The ESM ID (for example, ESM A)
 - The ESM port ID (for example, In, Out, 1A, or 1B)
 - The drive tray ID

Example label abbreviation – Assume that a cable is connected between drive channel 1, port 2 of controller A to the out port of the left ESM (A) in drive tray 1. A label abbreviation could be as follows:

CtA-Dch1/P2, Dm1-ESM_A (left), Out

6. Repeat step 1 through step 5 for each drive tray.
7. Remove the antistatic protection.

Step 6 – Running Diagnostics

1. Using the LEDs on the storage array and information provided by the storage management software, check the status of all trays in the storage array.
2. Does any component have a Needs Attention status?
 - **Yes** – Click the **Recovery Guru** toolbar button in the Array Management Window, and complete the recovery procedure. If a problem is still indicated, contact your Customer and Technical Support representative.
 - **No** – Go to step 3.
3. Create, save, and print a new storage array profile.